

L42 / SML42



Thin Film Limiter Module 50 to 4000 MHz

Rev. V2

Features

- VERY WIDE BANDWIDTH
- GOOD SUPPRESSION OF EVEN ORDER HARMONICS
- LOW INSERTION LOSS: 3.5 dB (TYP.)

Description

The L42 signal limiter is a discrete hybrid design, which uses thin film manufacturing processes for accurate performance and high reliability. This design uses Schottky bridge quad and anti-parallel diodes, which provide consistent limiting levels over a broadband frequency range. Both TO-8 and SMT0-8 packages are hermetically sealed, and MIL-STD-883 environmental screening is available.

Ordering Information

Part Number	Package
L42	TO-8
SML42	Surface Mount
CL42 **	SMA Connectorized

** The connectorized version is not RoHs compliant.

Product Image

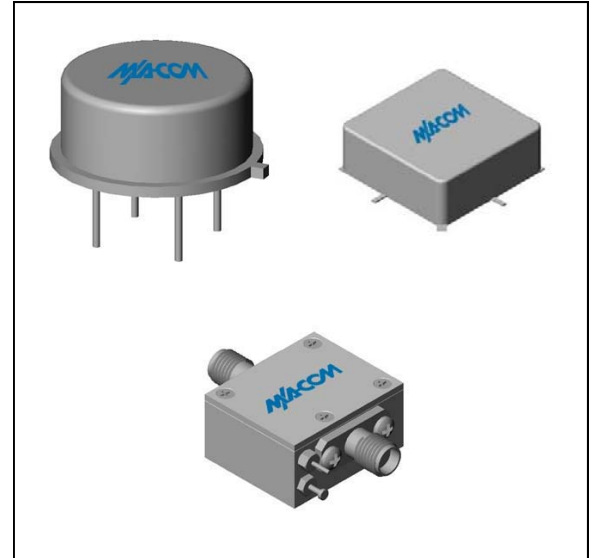

Electrical Specifications: $Z_0 = 50\Omega$, $V_{CC} = +15 V_{DC}$

Parameter	Units	Typical	Guaranteed	
		25°C	0° to 50°C	-54° to +85°C*
Frequency (min)	MHz	5-4000	50-4000	50-4000
Insertion Loss @ $P_{IN} \leq -20$ dBm (max.)	50-3000 MHz	3.5	4.5	5.0
	3000-4000 MHz	4.0	5.0	6.0
Input VSWR (max.) $P_{IN} \leq -10$ dBm, $+10 \leq \text{Bias} \leq +20 V_{dc}$		1.6:1	1.9:1	2.1:1
Output VSWR (max.) $P_{IN} \leq -10$ dBm, $+10 \leq \text{Bias} \leq +20 V_{dc}$		2.0:1	2.3:1	2.5:1
Output Limiting Level @ $P_{IN} = +20$ dBm (max.) $+15 \leq \text{Bias} \leq +20 V_{dc}$	50-2000 MHz	2.5	4.0	4.5
	2000-4000 MHz	6.5	7.0	7.5
Bias Current (max.)	@ +20 Vdc	8.5	9.0	10.0
	@ +15 Vdc	7.0		
	@ +10 Vdc	4.0		

* Over temperature performance limits for part number CL42, guaranteed from 0°C to +50°C only.

Absolute Maximum Ratings

Parameter	Absolute Maximum
Storage Temperature	-62°C to +125°C
Case Temperature	+125°C
DC Voltage	+25 V
Continuous Input Power	+20 dBm
Short Term Input power (1 minute max.)	400 mW
Peak Power (3 μ sec max.)	1 W
"S" Series Burn-In Temperature (case)	+125°C

Limiting and Insertion Loss Characteristics at +25°C

Bias Voltage	Output Level at Limiting Threshold (1 dB comp.)		
	1000 MHz	Typical 2500 MHz	4000 MHz
+20 Volts	-1.0 dBm	-2.5 dBm	-6.0 dBm
+15 Volts	-2.0 dBm	-4.0 dBm	-6.2 dBm
+10 Volts	-5.5 dBm	-7.0 dBm	-7.8 dBm
+5 Volts	-12.0 dBm	-13.8 dBm	-12.0 dBm

1

ADVANCED: Data Sheets contain information regarding a product M/A-COM Technology Solutions is considering for development. Performance is based on target specifications, simulated results, and/or prototype measurements. Commitment to develop is not guaranteed.

PRELIMINARY: Data Sheets contain information regarding a product M/A-COM Technology Solutions has under development. Performance is based on engineering tests. Specifications are typical. Mechanical outline has been fixed. Engineering samples and/or test data may be available. Commitment to produce in volume is not guaranteed.

• **North America** Tel: 800.366.2266 • **Europe** Tel: +353.21.244.6400
 • **India** Tel: +91.80.4155721 • **China** Tel: +86.21.2407.1588
 Visit www.macomtech.com for additional data sheets and product information.

M/A-COM Technology Solutions Inc. and its affiliates reserve the right to make changes to the product(s) or information contained herein without notice.

Typical Performance Curves at +25°C

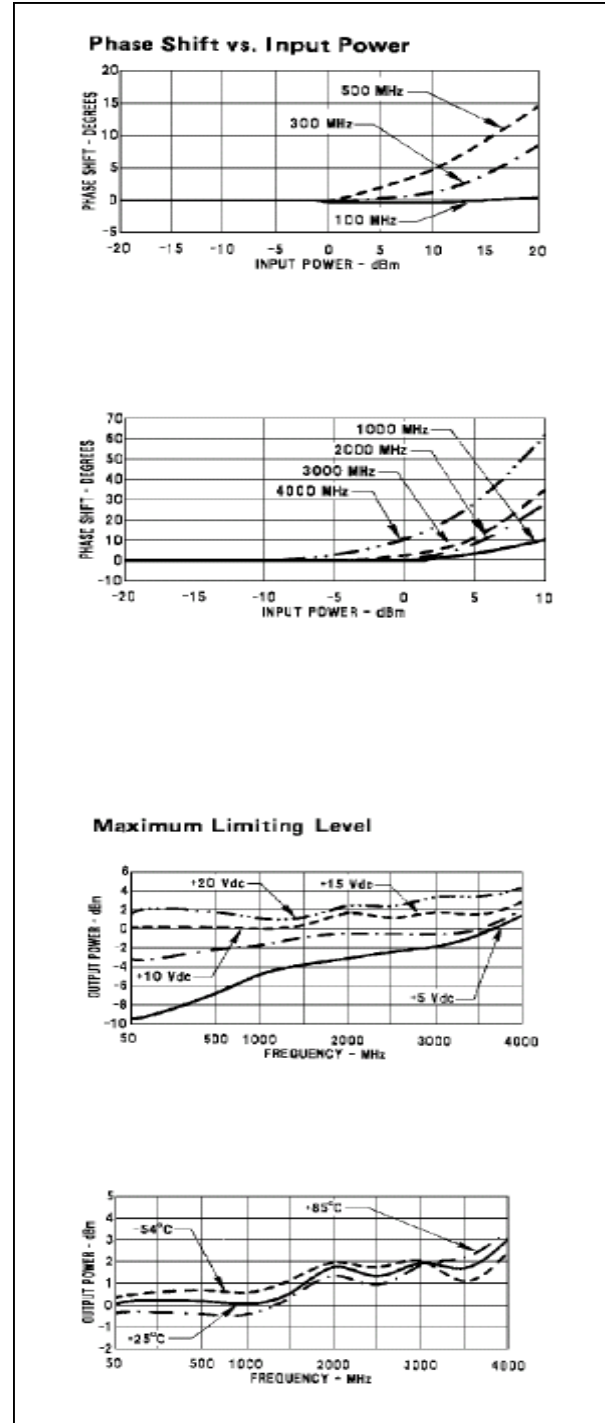
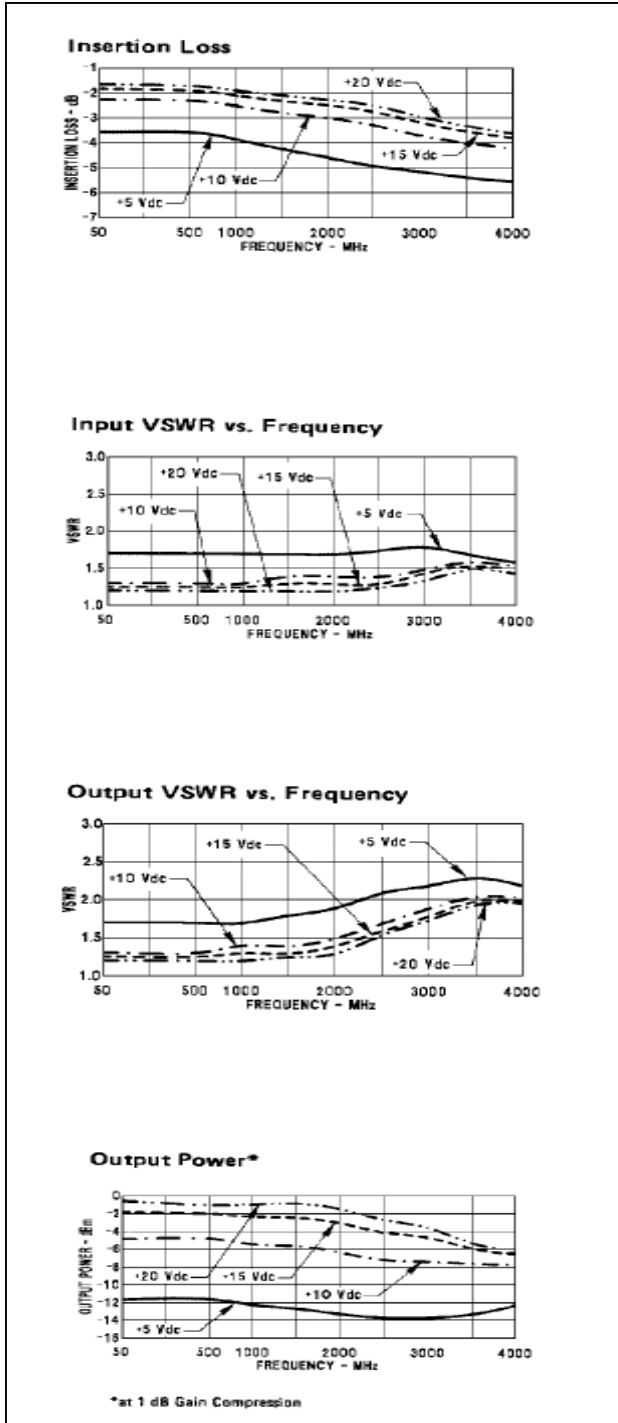

L42 / SML42

Thin Film Limiter Module
50 to 4000 MHz

Rev. V2

Typical Performance Curves at +25°C

Outline Drawing: TO-8 *

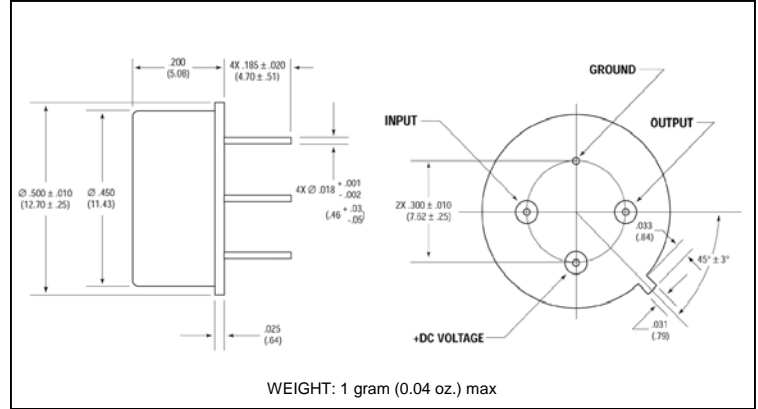
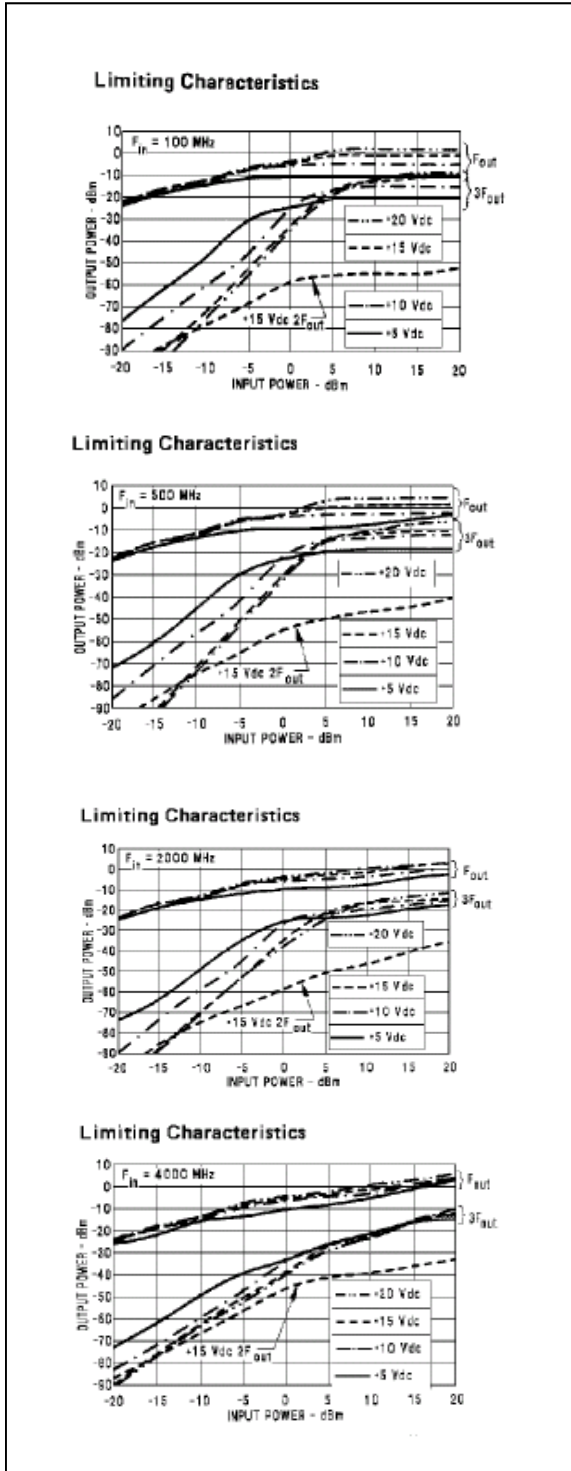

Outline Drawing: Surface Mount *

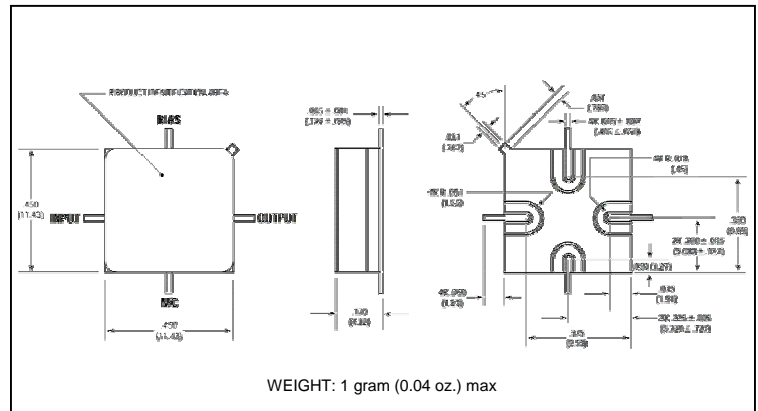

Outline Drawing: SMA Connectorized *

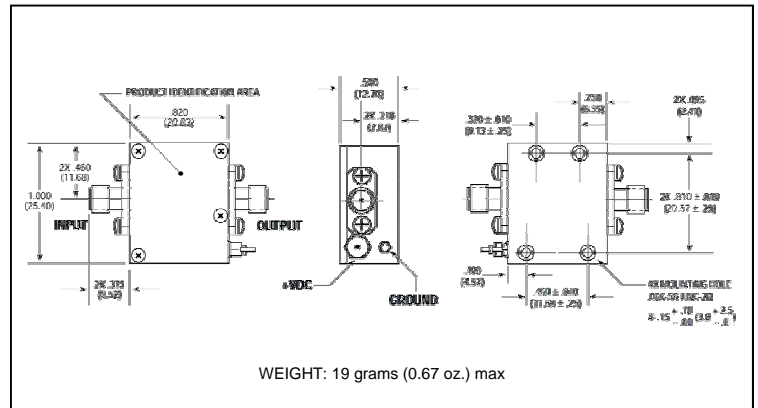

* Dimensions are inches (millimeters) ± 0.015 (0.38) unless otherwise specified.

Данный компонент на территории Российской Федерации

Вы можете приобрести в компании MosChip.

Для оперативного оформления запроса Вам необходимо перейти по данной ссылке:

<http://moschip.ru/get-element>

Вы можете разместить у нас заказ для любого Вашего проекта, будь то серийное производство или разработка единичного прибора.

В нашем ассортименте представлены ведущие мировые производители активных и пассивных электронных компонентов.

Нашей специализацией является поставка электронной компонентной базы двойного назначения, продукции таких производителей как XILINX, Intel (ex.ALTERA), Vicor, Microchip, Texas Instruments, Analog Devices, Mini-Circuits, Amphenol, Glenair.

Сотрудничество с глобальными дистрибьюторами электронных компонентов, предоставляет возможность заказывать и получать с международных складов практически любой перечень компонентов в оптимальные для Вас сроки.

На всех этапах разработки и производства наши партнеры могут получить квалифицированную поддержку опытных инженеров.

Система менеджмента качества компании отвечает требованиям в соответствии с ГОСТ Р ИСО 9001, ГОСТ РВ 0015-002 и ЭС РД 009

Офис по работе с юридическими лицами:

105318, г.Москва, ул.Щербаковская д.3, офис 1107, 1118, ДЦ «Щербаковский»

Телефон: +7 495 668-12-70 (многоканальный)

Факс: +7 495 668-12-70 (доб.304)

E-mail: info@moschip.ru

Skype отдела продаж:

moschip.ru

moschip.ru_4

moschip.ru_6

moschip.ru_9