



Call for additional listings

- 3 settings at 12 VDC
- 6 settings at 24 VDC
- Strobe output selection view window
- Pre-wire back plate
- Universal back plate mounting (single gang, double gang, octagon, or 4" square)
- Single screw mounting
- 33 sound output settings
- Indoor or outdoor
- Anodized reflector for true light output
- UL and cUL listed

Patents pending

* Outdoor installation requires the BBK-1 #1500001, BBX-5R #4270048, or BBX-5W #4270049

The CSH-1224W Strobe/Horn Series provides a wide range of candela light output options in a single device. The candela settings include a 12 or 24 volt DC operation for the 1-3 settings candela settings and 24 volt DC operation for the 1-6 candela settings. The candela setting is displayed through the front window and is selectable using a drum wheel.

The horn settings include Temporal, Non-Temporal, March Time and a Chime sound. The horn also has Low, Mid and High volume settings for each pattern and tone. The tones include 2400 Hz, Electro-Mechanical, Broadband and Chime.

The voltage input can be either regulated DC or full wave rectified (FWR) 12 volt or 24 volt operation with an operating range of 8 to

33V DC. The strobes can be synchronized using a control panel with the Potter (Amseco) sync protocol or SMD10-3A sync module.

The CSH-1224W utilizes a universal mounting plate that will mount on a single gang, double gang, octagon and 4" square electrical boxes. The back plate allows the installer to mount the plate and terminate the wire connections. The strobe/horn attaches in a hinge fashion from the top and is secured by a single mounting screw. The strobe/horn completely covers the mounting back plate, therefore it can be mounted before other trades work is completed and not affect the final look.

The Potter mass notification strobe/horn is listed for indoor and outdoor installations. For outdoor installations, the device must be mounted on a matching BBX-5 or BBK-1 outdoor bell back box.

Installation

Note: Installation must comply in accordance with applicable standards.

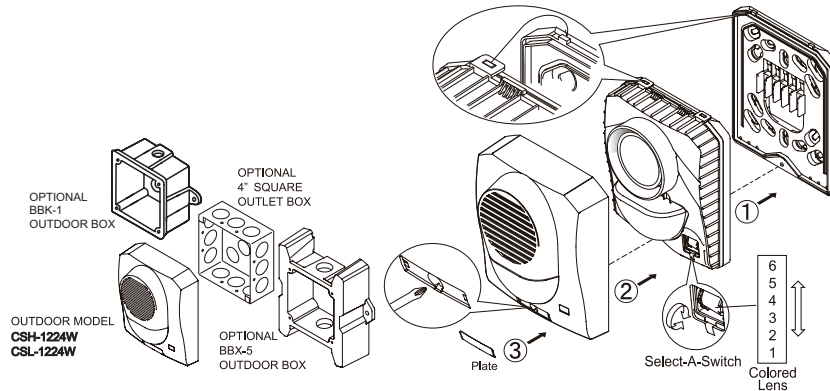

Ordering Information

Stock Number	Model Number	Body Color	Lens Color
4800051	CSH-1224W-AR	Red	Amber
4800052	CSH-1224W-AW	White	Amber
4800053	CSH-1224W-BR	Red	Blue
4800054	CSH-1224W-BW	White	Blue
4800055	CSH-1224W-GR	Red	Green
4800056	CSH-1224W-GW	White	Green
4800057	CSH-1224W-RR	Red	Red
4800058	CSH-1224W-RW	White	Red

Dimensions: inches (mm)

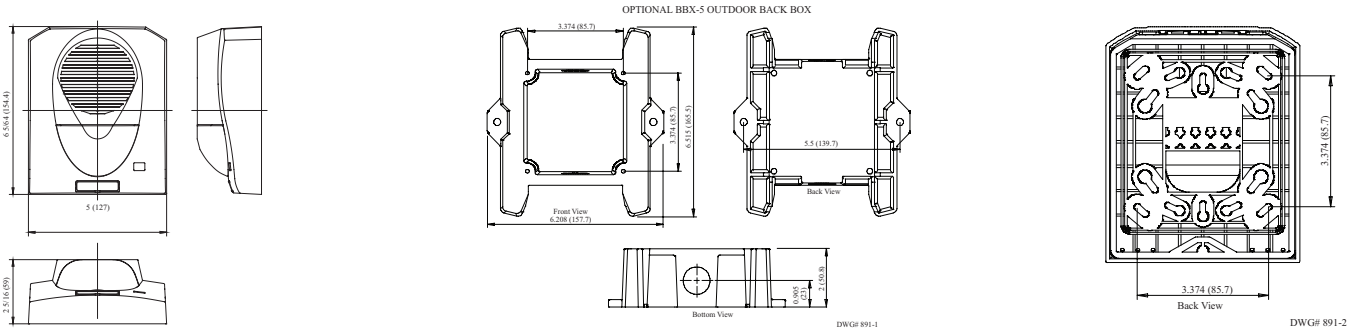

⚠ WARNING

High voltage may be present inside the light assembly even though power is not connected. If access to the component board is required (removal or replacement), the capacitor must be discharged by touching a wire to both ends of the flashtube.

DO NOT attempt to touch or move the assembly until the capacitor has been discharged.

Horn Dipswitch

Pattern

- 1 ON - Non-temporal
- 1 OFF - Temporal
- Both 2 = OFF
- 1 and 2 ON = March Time

Tone

- 3 and 4 ON = 2400Hz
- 3 ON and 4 OFF = Electromechanical
- 3 and 4 OFF = Chime
- 3 OFF and 4 ON = Broadband

Volume

- 5 and 6 ON = High
- 5 ON and 6 OFF = Mid
- 5 and 6 OFF = Low
- 7 and 8 ON = Horn/strobe on 2 wires
- 7 and 8 OFF = Horn/strobe on 4 wires

Specifications

Strobe Current

Set-ting	Light Output	Max. RMS Operating Current (mA RMS)			
		Reg. 12 VDC	Reg. 12 FWR	Reg. 24 VDC	Reg. 24 FWR
1	15cd	129	185	100	102
2	35cd	160	214	135	161
3	60/75cd	193	239	171	202
4	75cd	NA	NA	190	228
5	95cd	NA	NA	211	255
6	110cd	NA	NA	225	284

Voltage	12/24V	
UL Designation	Regulated 12 DC/FWR	Regulated 24 DC/FWR
Operating Voltage Range	8 - 17.5V	16 - 33V
Flash Rate	60 times/min.	
Sync Module (SMD10-3A)	NA	Available
Operating Temperature Range	Indoor model: 32°F to 120°F (0°C to 49°C) Outdoor model: -40°F to 151°F (-40°C to 66°C)	

Candela Output

Select-A-Switch	Light Output on Axis (cd)			
	Amber	Blue	Green	Red
1	14	10	13	7
2	37	20	39	17
3	49	28	50	18
4	69	41	77	28
5	83	51	94	35
6	99	58	109	38

Note: To determine total current draw, add desired strobe setting and horn selection. Refer to the installation instructions for further information.

Non-Temporal Horn Current

Pattern	Volume	Max. RMS Current (mA RMS Current)		dBA Reverberant Ratings per UL464 (dBA @ 10 ft.)		dBA Anechoic Ratings per CAN/ULC S525 (dBA @ 10 ft.)	
		Reg 12 VDC	Reg 24 VDC	Reg 12 VDC	Reg 24 VDC	Reg 12 VDC	Reg 24 VDC
2400 Hz	High	119	87	87	87	99	100
	Mid	44	28	82	82	94	96
	Low	30	18	79	80	92	92
Electro-Mechanical	High	118	81	86	87	100	100
	Mid	43	26	82	84	96	97
	Low	27	16	79	80	93	93
Broadband	High	146	78	86	86	101	102
	Mid	41	26	81	82	96	98
	Low	28	16	77	79	94	95
Chime	High	27	21	70	70	86	86
	Mid	11	8	62	62	79	80
	Low	9	7	58	57	75	75

Temporal Horn Current

Pattern	Volume	Max. RMS Current (mA RMS Current)		dBA Reverberant Ratings per UL464 (dBA @ 10 ft.)		dBA Anechoic Ratings per CAN/ULC S525 (dBA @ 10 ft.)	
		Reg 12 VDC	Reg 24 VDC	Reg 12 VDC	Reg 24 VDC	Reg 12 VDC	Reg 24 VDC
2400 Hz	High	124	87	82	82	100	100
	Mid	46	30	77	79	95	96
	Low	30	18	74	75	92	92
Electro-Mechanical	High	114	80	83	82	100	101
	Mid	42	27	78	80	95	96
	Low	28	16	75	76	93	93
Broadband	High	151	80	82	82	101	102
	Mid	45	26	77	78	97	98
	Low	30	16	75	76	94	95
Chime	High	29	21	68	70	86	86
	Mid	10	9	61	61	79	79
	Low	9	8	55	55	75	76

March Time Horn Current

Pattern	Volume	Max. RMS Current (mA RMS Current)		dBA Reverberant Ratings per UL464 (dBA @ 10 ft.)		dBA Anechoic Ratings per CAN/ULC S525 (dBA @ 10 ft.)	
		Reg 12 VDC	Reg 24 VDC	Reg 12 VDC	Reg 24 VDC	Reg 12 VDC	Reg 24 VDC
2400 Hz	High	121	92	83	84	99	100
	Mid	47	31	79	81	95	96
	Low	36	19	76	77	92	92
Electro-Mechanical	High	114	86	83	83	100	100
	Mid	42	27	80	81	95	96
	Low	30	19	77	77	92	93
Broadband	High	153	77	83	84	101	102
	Mid	42	28	79	80	97	98
	Low	29	16	76	77	94	95

Wiring Diagram

Wiring Observe Polarity Use both terminals (or Lead) for connection. Break wire run to provide electrical supervision.

Horn / Strobe Signal Operate Independently

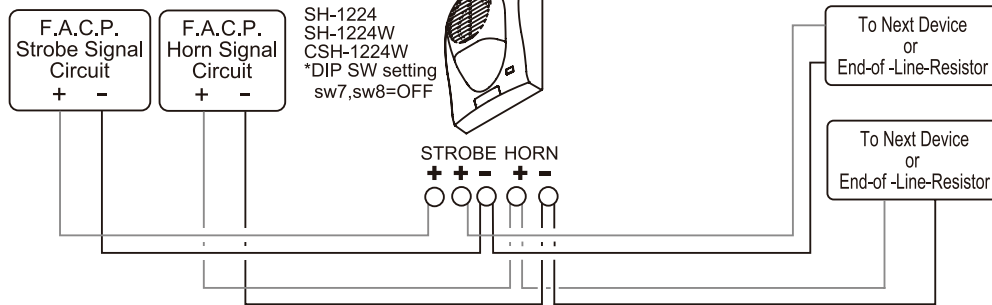

Horn / Strobe Wiring Diagram for Audible Strobe Class "B" Circuit with Audible Silence Feature. (SH-1224, SH1224W)

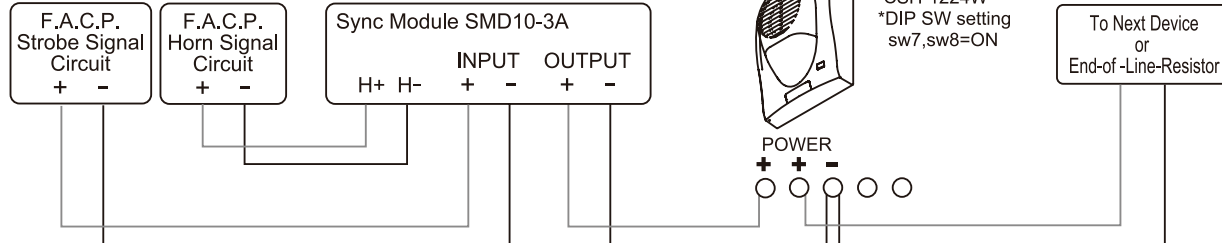

Horn or Strobe Wiring Diagram for Audible Strobe Class "B" Circuit without Audible Silence Feature.

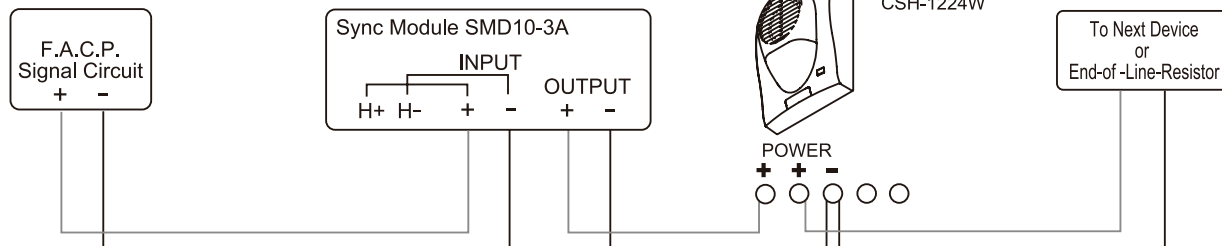

Refer to the SMD 10-3A Sync Module instruction manual for Class "A" wiring or other application diagrams.

DWG# 8910012-1

Engineering Specifications

The installer shall provide and install the Potter CSH-1224W selectable strobe/horn. The strobe shall have six (6) selectable settings. The selectable settings shall be selectable using a drum roller and shall display the setting on the front of the device. The strobe shall have a colored lens and anodized reflector. A colored lens on a standard reflector shall not be acceptable. The horn shall have 33 selectable settings configurable by dip switches. The sounder shall be capable of ANSI Temporal Code 3, March Time and produce a chime output. The horn shall have three distinct volume levels. The strobe/horn shall operate at 12 or 24 VDC regulated or full wave rectified. The strobe/horn shall have an operating range between 8 and 33 VDC. The strobe/horn shall utilize a mounting plate that allows the installer to pre-wire the mounting plate. The mounting plate shall be

universal and mount on a single gang, double gang, octagon or 4 inch square box. The mounting plate shall be completely covered by the strobe/horn and shall be secured by a single screw. The device shall be listed for indoor and outdoor applications. Outdoor installations shall require a matching BBX-5 or BBK-1 weatherproof bell back box. The operating range shall be 32°F to 120°F (0°C to 49°C) for the indoor installations and -40°F to 151°F (-40°C to 66°C) for the outdoor installations. The strobe/horn shall be UL listed to standard 1638, General Signaling, and standard 1971, Signaling Devices for the Hearing Impaired. In addition, the strobe/horns shall be cUL listed to CAN-ULC S526. The horn shall be UL listed to standard 464, Audible Signaling Devices.

Данный компонент на территории Российской Федерации

Вы можете приобрести в компании MosChip.

Для оперативного оформления запроса Вам необходимо перейти по данной ссылке:

<http://moschip.ru/get-element>

Вы можете разместить у нас заказ для любого Вашего проекта, будь то серийное производство или разработка единичного прибора.

В нашем ассортименте представлены ведущие мировые производители активных и пассивных электронных компонентов.

Нашей специализацией является поставка электронной компонентной базы двойного назначения, продукции таких производителей как XILINX, Intel (ex.ALTERA), Vicor, Microchip, Texas Instruments, Analog Devices, Mini-Circuits, Amphenol, Glenair.

Сотрудничество с глобальными дистрибьюторами электронных компонентов, предоставляет возможность заказывать и получать с международных складов практически любой перечень компонентов в оптимальные для Вас сроки.

На всех этапах разработки и производства наши партнеры могут получить квалифицированную поддержку опытных инженеров.

Система менеджмента качества компании отвечает требованиям в соответствии с ГОСТ Р ИСО 9001, ГОСТ РВ 0015-002 и ЭС РД 009

Офис по работе с юридическими лицами:

105318, г.Москва, ул.Щербаковская д.3, офис 1107, 1118, ДЦ «Щербаковский»

Телефон: +7 495 668-12-70 (многоканальный)

Факс: +7 495 668-12-70 (доб.304)

E-mail: info@moschip.ru

Skype отдела продаж:

moschip.ru

moschip.ru_4

moschip.ru_6

moschip.ru_9