

Product Specification

1.25Gb/s RoHS Compliant Long-Wavelength Pluggable SFP Transceiver

FTLF1518P1BTL

PRODUCT FEATURES

- Up to 1.25Gb/s bi-directional data links
- Hot-pluggable SFP footprint
- Built-in digital diagnostic functions
- Uncooled 1550nm DFB laser transmitter
- Duplex LC connector
- RoHS compliant and Lead Free
- Metal enclosure, for lower EMI
- Single 3.3V power supply
- Up to 80 km on 9/125µm SMF
- Low power dissipation typically <700mW
- Industrial operating temperature range: -40°C to 85°C



APPLICATIONS

- Gigabit Ethernet
- 1X Fibre Channel

Finisar's FTLF1518P1BTL Small Form Factor Pluggable (SFP) transceivers are compatible with the Small Form Factor Pluggable Multi-Sourcing Agreement (MSA)¹. They simultaneously comply with Gigabit Ethernet as specified in IEEE Std 802.3², and 1x Fibre Channel as defined in FC-PI-4 Rev 8.00^{3,4}. They are RoHS compliant and lead-free per Directive 2002/95/EC⁵ and Finisar Application Note AN-2038. Digital diagnostics functions are available via the 2-wire serial bus specified in the SFP MSA.

PRODUCT SELECTION

FTLF1518P1BTL

I. Pin Descriptions

Pin	Symbol	Name/Description	Ref.
1	V _{EET}	Transmitter Ground (Common with Receiver Ground)	1
2	T _{FAULT}	Transmitter Fault. Not supported.	
3	T _{DIS}	Transmitter Disable. Laser output disabled on high or open.	2
4	MOD_DEF(2)	Module Definition 2. Data line for Serial ID.	3
5	MOD_DEF(1)	Module Definition 1. Clock line for Serial ID.	3
6	MOD_DEF(0)	Module Definition 0. Grounded within the module.	3
7	Rate Select	No connection required	4
8	LOS	Loss of Signal indication. Logic 0 indicates normal operation.	5
9	V _{EER}	Receiver Ground (Common with Transmitter Ground)	1
10	V _{EER}	Receiver Ground (Common with Transmitter Ground)	1
11	V _{EER}	Receiver Ground (Common with Transmitter Ground)	1
12	RD-	Receiver Inverted DATA out. AC Coupled	
13	RD+	Receiver Non-inverted DATA out. AC Coupled	
14	V _{EER}	Receiver Ground (Common with Transmitter Ground)	1
15	V _{CCR}	Receiver Power Supply	
16	V _{CCT}	Transmitter Power Supply	
17	V _{EET}	Transmitter Ground (Common with Receiver Ground)	1
18	TD+	Transmitter Non-Inverted DATA in. AC Coupled.	
19	TD-	Transmitter Inverted DATA in. AC Coupled.	
20	V _{EET}	Transmitter Ground (Common with Receiver Ground)	1

Notes:

1. Circuit ground is internally isolated from chassis ground.
2. Laser output disabled on T_{DIS} >2.0V or open, enabled on T_{DIS} <0.8V.
3. Should be pulled up with 4.7k - 10 kohms on host board to a voltage between 2.0V and 3.6V. MOD_DEF(0) pulls line low to indicate module is plugged in.
4. Finisar FTLFxx19xxxxx transceivers operate at 1x and 2x Fibre Channel, and Gigabit Ethernet data rates and respective protocols without active control.
5. LOS is open collector output. Should be pulled up with 4.7k – 10 kohms on host board to a voltage between 2.0V and 3.6V. Logic 0 indicates normal operation; logic 1 indicates loss of signal.

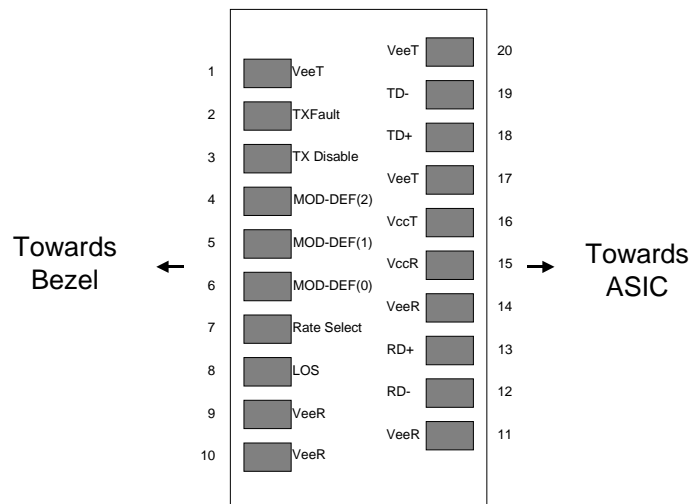

Pinout of Connector Block on Host Board

II. Absolute Maximum Ratings

Parameter	Symbol	Min	Typ	Max	Unit	Ref.
Maximum Supply Voltage	V _{CC}	-0.5		4.5	V	
Storage Temperature	T _S	-40		85	°C	
Case Operating Temperature	T _{OP}	-40		85	°C	
Relative Humidity	RH	0		85	%	1

III. Electrical Characteristics (T_{OP} = -40 to 85 °C, V_{CC} = 3.00 to 3.60 Volts)

Parameter	Symbol	Min	Typ	Max	Unit	Ref.
Supply Voltage	V _{CC}	3.15		3.60	V	
Supply Current	I _{CC}		200	300	mA	
Transmitter						
Input differential impedance	R _{in}		100		Ω	2
Single ended data input swing	V _{in,pp}	250		1200	mV	
Transmit Disable Voltage	V _D	V _{CC} – 1.3		V _{CC}	V	
Transmit Enable Voltage	V _{EN}	V _{EE}		V _{EE} + 0.8	V	3
Transmit Disable Assert Time				10	us	
Receiver						
Single ended data output swing	V _{out,pp}	300	400	800	mV	4
Data output rise time	t _r		100	175	ps	5
Data output fall time	t _f		100	175	ps	5
LOS Fault	V _{LOS_fault}	V _{CC} – 0.5		V _{CC_HOST}	V	6
LOS Normal	V _{LOS_norm}	V _{EE}		V _{EE} +0.5	V	6
Power Supply Rejection	PSR	100			mVpp	7
Deterministic Jitter Contribution	RX Δ DJ			51.7	ps	8
Total Jitter Contribution	RX Δ TJ			122.4	ps	

Notes:

1. Non condensing.
2. Connected directly to TX data input pins. AC coupled thereafter.
3. Or open circuit.
4. Into 100 ohms differential termination.
5. 20 – 80 %
6. Loss Of Signal is LVTTTL. Logic 0 indicates normal operation; logic 1 indicates no signal detected.
7. Receiver sensitivity is compliant with power supply sinusoidal modulation of 20 Hz to 1.5 MHz up to specified value applied through the recommended power supply filtering network. Valid on receive side for input powers within receive sensitivity.
8. Measured with DJ-free data input signal. In actual application, output DJ will be the sum of input DJ and Δ DJ.

IV. Optical Characteristics (T_{OP} = -40 to 85°C, V_{CC} = 3.00 to 3.60 Volts)

Parameter	Symbol	Min	Typ	Max	Unit	Ref.
Transmitter						
Output Opt. Pwr: 9/125 SMF	P _{OUT}	0		5	dBm	1
Optical Wavelength	λ	1540		1570	nm	2
Spectral Width (-20dB)	σ			1	nm	2
Optical Extinction Ratio	ER	9			dB	
Optical Modulation Amplitude	OMA	174			μW	2,3
Sidemode Suppression ratio	SSR _{min}	30			dB	
Optical Rise/Fall Time	t _r /t _f			180	ps	4
Relative Intensity Noise	RIN			-120	dB/Hz	
Deterministic Jitter Contribution	RX Δ DJ			51.7	ps	5
Total Jitter Contribution	RX Δ TJ			122.4	ps	
Receiver						
Average Rx Sensitivity	R _{SENS}			-22	dBm	6, 7
Stressed RX sens. =1.25 Gb/s			-18	-14.5	dBm	
Average Received Power	R _{XMAX}			0	dBm	
Receiver Elec. 3 dB cutoff freq.				1500	MHz	
Optical Center Wavelength	λ _C	1270		1600	nm	
Return Loss		12			dB	
LOS De-Assert	LOS _D			-23	dBm	
LOS Assert	LOS _A	-32			dBm	
LOS Hysteresis		0.5			dB	

Notes:

1. Class 1 Laser Safety per FDA/CDRH and EN (IEC) 60825 regulations.
2. Meets curve in FC-PI-4 Rev 8.00 Figure 21, which allows trade-off between wavelength, spectral width and OMA.
3. Equivalent extinction ratio specification for Fibre Channel. Allows smaller ER at higher average power.
4. Unfiltered, 20-80%. Complies with IEEE 802.3 (Gig. E), FC 1x eye mask when filtered.
5. Measured with DJ-free data input signal. In actual application, output DJ will be the sum of input DJ and Δ DJ.
6. Measured with conformance signals defined in FC-PI-4 Rev 8.00 specifications.
7. Measured with PRBS 2⁷-1 at 10⁻¹² BER

V. General Specifications

Parameter	Symbol	Min	Typ	Max	Units	Ref.
Data Rate	BR	1062		1250	Mb/sec	1
Bit Error Rate	BER			10^{-12}		2
Max. Supported Link Length on 9/125 μ m SMF @ Gigabit Ethernet	L _{MAX}		88		km	3, 4

Notes:

1. Gigabit Ethernet and 1x Fibre Channel compliant.
2. Tested with a PRBS 2⁷-1 test pattern.
3. Dispersion limited per FC-PI-4 Rev 8.00
4. Attenuation of 0.25 dB/km is used for the link length calculations. Distances are indicative only and are calculated solely on link budget. A 2dB penalty is included for dispersion on >2Gb/s data rates. Please refer to the Optical Specifications in Table IV to calculate a more accurate link budget based on specific conditions in your application.

VI. Environmental Specifications

Finisar 1550nm SFP transceivers have an extended operating temperature range from -40°C to +85°C case temperature.

Parameter	Symbol	Min	Typ	Max	Units	Ref.
Case Operating Temperature	T _{op}	-40		85	°C	
Storage Temperature	T _{sto}	-40		85	°C	

VII. Regulatory Compliance

Finisar transceivers are Class 1 Laser Products and comply with US FDA regulations. These products are certified by TÜV and CSA to meet the Class 1 eye safety requirements of EN (IEC) 60825 and the electrical safety requirements of EN (IEC) 60950. Copies of certificates are available at Finisar Corporation upon request. Copies of the referenced certificates are available at Finisar Corporation upon request.

VIII. Digital Diagnostic Functions

Finisar FTLF1518P1BTL SFP transceivers support the 2-wire serial communication protocol as defined in the SFP MSA¹. It is very closely related to the E²PROM defined in the GBIC standard, with the same electrical specifications.

The standard SFP serial ID provides access to identification information that describes the transceiver's capabilities, standard interfaces, manufacturer, and other information.

Additionally, Finisar SFP transceivers provide a unique enhanced digital diagnostic monitoring interface, which allows real-time access to device operating parameters such as transceiver temperature, laser bias current, transmitted optical power, received optical power and transceiver supply voltage. It also defines a sophisticated system of alarm and warning flags, which alerts end-users when particular operating parameters are outside of a factory set normal range.

The SFP MSA defines a 256-byte memory map in E²PROM that is accessible over a 2-wire serial interface at the 8 bit address 1010000X (A0h). The digital diagnostic monitoring interface makes use of the 8 bit address 1010001X (A2h), so the originally defined serial ID memory map remains unchanged. The interface is identical to, and is thus fully backward compatible with both the GBIC Specification and the SFP Multi Source Agreement. The complete interface is described in Finisar Application Note AN-2030: "Digital Diagnostics Monitoring Interface for SFP Optical Transceivers".

The operating and diagnostics information is monitored and reported by a Digital Diagnostics Transceiver Controller (DDTC) inside the transceiver, which is accessed through a 2-wire serial interface. When the serial protocol is activated, the serial clock signal (SCL, Mod Def 1) is generated by the host. The positive edge clocks data into the SFP transceiver into those segments of the E²PROM that are not write-protected. The negative edge clocks data from the SFP transceiver. The serial data signal (SDA, Mod Def 2) is bi-directional for serial data transfer. The host uses SDA in conjunction with SCL to mark the start and end of serial protocol activation. The memories are organized as a series of 8-bit data words that can be addressed individually or sequentially.

For more information, please see the SFP MSA documentation¹ or Finisar Application Note AN-2030.

Digital diagnostics for the FTLF1518P1BTL are externally calibrated by default.

Please note that evaluation board FDB-1018 is available with Finisar ModDEMO software that allows simple to use communication over the 2-wire serial interface.

IX. Mechanical Specifications

Finisar’s FTLF1518P1BTL Small Form Factor Pluggable (SFP) transceivers are compatible with the dimensions defined by the SFP Multi-Sourcing Agreement (MSA).

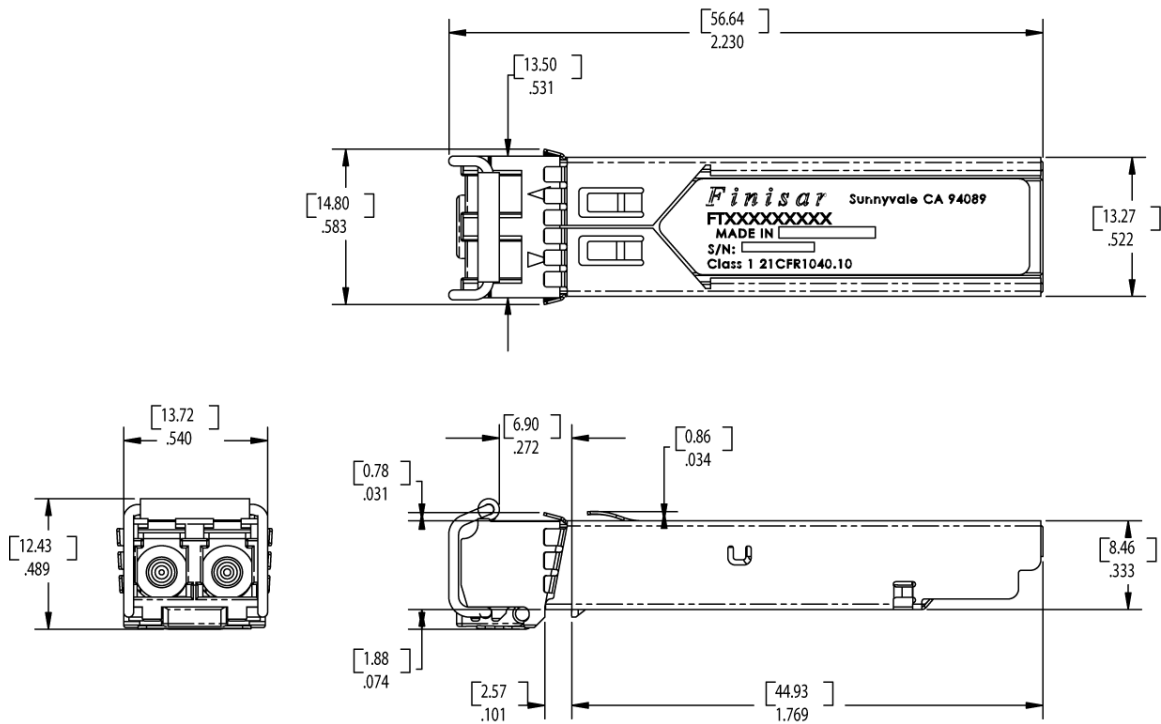

FTLF1518P1BTL

X. PCB Layout and Bezel Recommendations

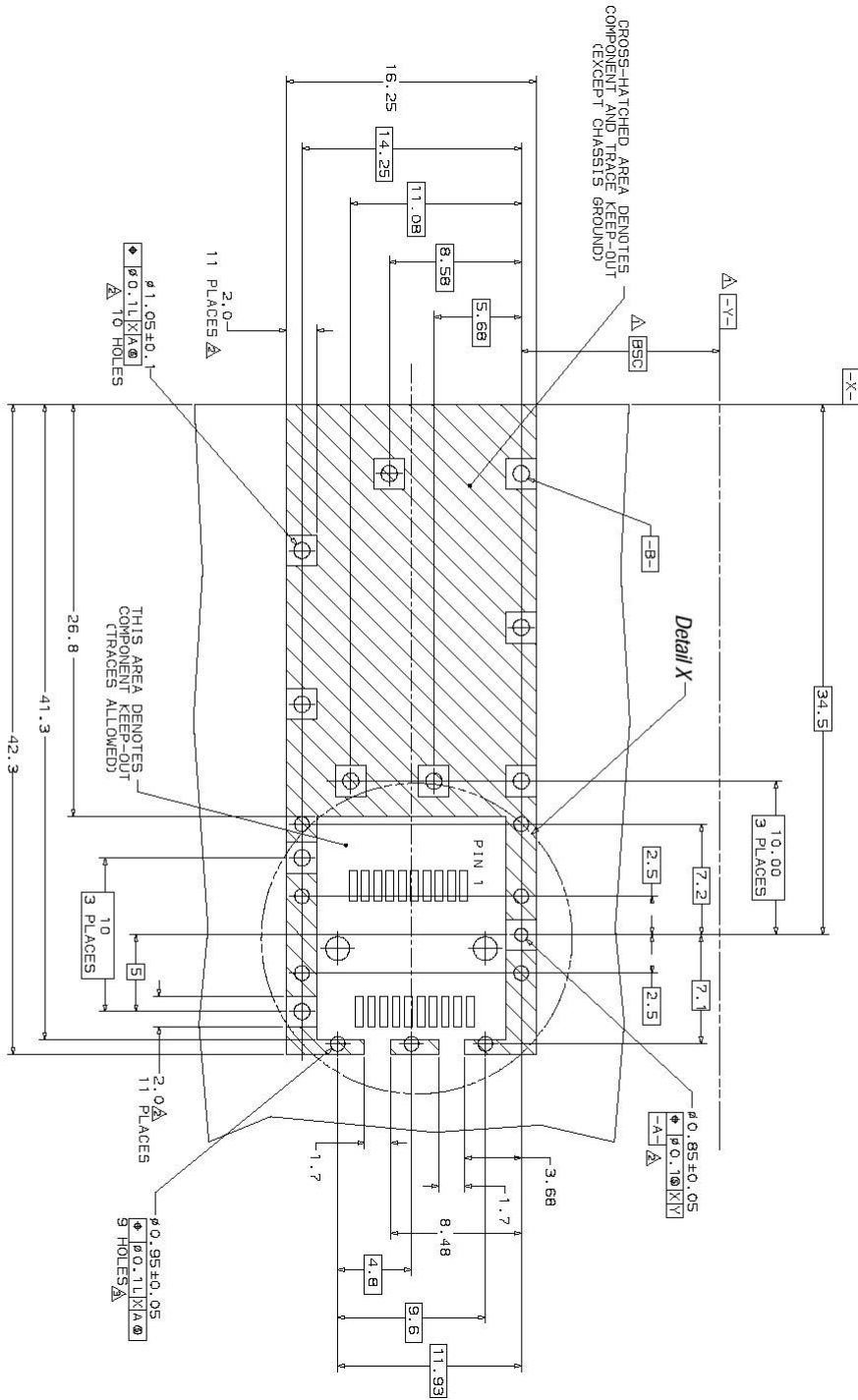

- Δ Datum and Basic Dimension Established by Customer
- Δ Pads and Vias are Chassis Ground, 11 Places
- Δ Through Holes are Unplated

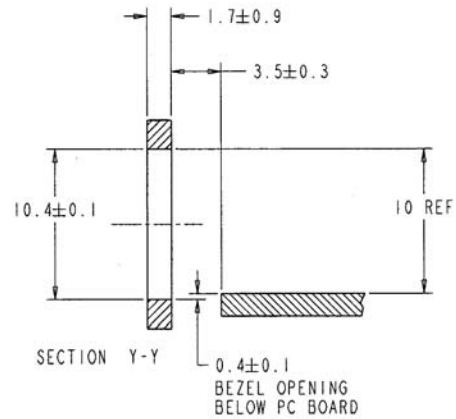
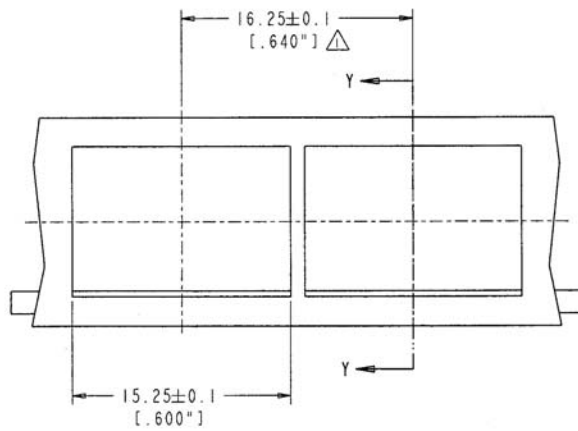
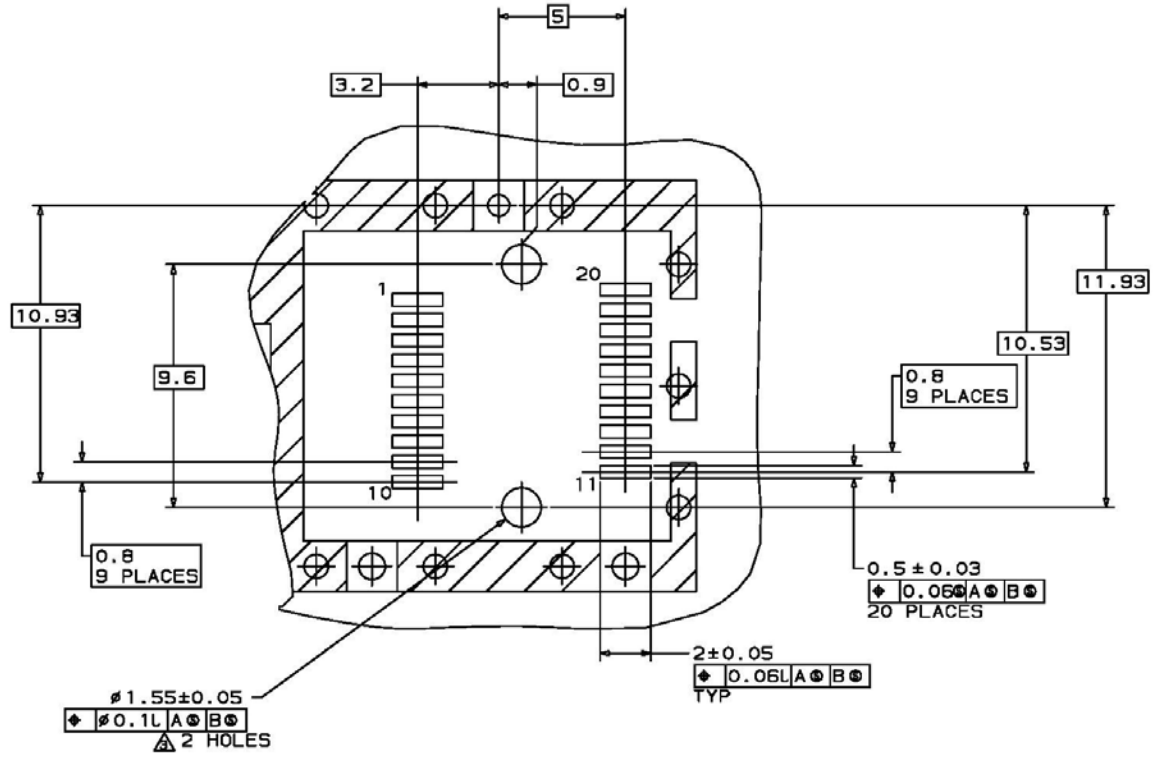

NOTES:

△ MINIMUM PITCH ILLUSTRATED, ENGLISH DIMENSIONS ARE FOR REFERENCE ONLY

2. NOT RECOMMENDED FOR PCI EXPANSION CARD APPLICATIONS

XI. References

1. Small Form Factor Pluggable (SFP) Transceiver Multi-Source Agreement (MSA), September 2000. Documentation is currently available at Finisar upon request.
2. IEEE Std 802.3. IEEE Standards Department, 2002.
3. “Fibre Channel Draft Physical Interface Specification (FC-PI-4 Rev 8.00)”. American National Standard for Information Systems.(*)
4. “Fibre Channel Physical and Signaling Interface (FC-PH, FC-PH2, FC-PH3)”. American National Standard for Information Systems.
5. Directive 2002/95/EC of the European Council Parliament and of the Council, “on the restriction of the use of certain hazardous substances in electrical and electronic equipment.” January 27, 2003.

(*) FC-PI-4 Rev 8.00 does not specify a 1550nm DFB interface for extended reach applications. The FTLF1518P1BTL complies with this standard, except for the optical output power. See section IV for details.

XII. For More Information

Finisar Corporation
1389 Moffett Park Drive
Sunnyvale, CA 94089-1134
Tel. 1-408-548-1000
Fax 1-408-541-6138
sales@finisar.com
www.finisar.com

Данный компонент на территории Российской Федерации

Вы можете приобрести в компании MosChip.

Для оперативного оформления запроса Вам необходимо перейти по данной ссылке:

<http://moschip.ru/get-element>

Вы можете разместить у нас заказ для любого Вашего проекта, будь то серийное производство или разработка единичного прибора.

В нашем ассортименте представлены ведущие мировые производители активных и пассивных электронных компонентов.

Нашей специализацией является поставка электронной компонентной базы двойного назначения, продукции таких производителей как XILINX, Intel (ex.ALTERA), Vicor, Microchip, Texas Instruments, Analog Devices, Mini-Circuits, Amphenol, Glenair.

Сотрудничество с глобальными дистрибьюторами электронных компонентов, предоставляет возможность заказывать и получать с международных складов практически любой перечень компонентов в оптимальные для Вас сроки.

На всех этапах разработки и производства наши партнеры могут получить квалифицированную поддержку опытных инженеров.

Система менеджмента качества компании отвечает требованиям в соответствии с ГОСТ Р ИСО 9001, ГОСТ РВ 0015-002 и ЭС РД 009

Офис по работе с юридическими лицами:

105318, г.Москва, ул.Щербаковская д.3, офис 1107, 1118, ДЦ «Щербаковский»

Телефон: +7 495 668-12-70 (многоканальный)

Факс: +7 495 668-12-70 (доб.304)

E-mail: info@moschip.ru

Skype отдела продаж:

moschip.ru

moschip.ru_4

moschip.ru_6

moschip.ru_9