

Switch, SP2T 100 Watt Reflective 0.5 - 6.0 GHz

Rev. V1

Features

- Suitable for Large Signal Broadband Applications
- Power Handling: 100 W @ 85°C
- Insertion Loss: 0.5 dB @ 4 GHz
- Isolation: 35 dB @ 4 GHz
- Lead-Free 4 mm HQFN-20LD Package
- RoHS* Compliant

Description

The MASW-011060 is a high power PIN diode SP2T switch in a common anode configuration, operating from 0.5 to 6.0 GHz. It features low insertion loss and excellent linearity. This device is capable of handling 100 Watts CW of incident power at a base plate temperature of 85°C.

This high power switch is ideal for use on broadband, MIL-COM, IED, and cellular applications that require higher CW and pulsed power operation.

The MASW-011060 is manufactured using MACOM's hybrid manufacturing process featuring high voltage PIN diodes and passive devices integrated in a 4 mm HQFN 20-lead plastic package.

Functional Schematic

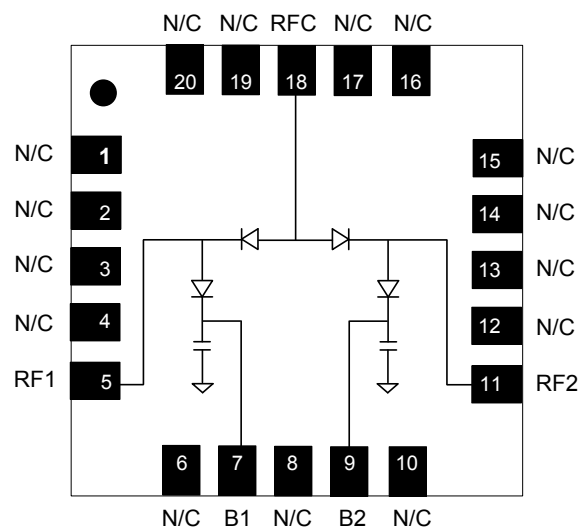

Pin Configuration³

Pin	Function	Pin	Function
1	No Connection	11	RF2 / V2 Bias
2	No Connection	12	No Connection
3	No Connection	13	No Connection
4	No Connection	14	No Connection
5	RF1 / V1 Bias	15	No Connection
6	No Connection	16	No Connection
7	B1 Bias	17	No Connection
8	No Connection	18	RFC / V3 Bias
9	B2 Bias	19	No Connection
10	No Connection	20	No Connection
		Paddle ⁴	Ground

3. MACOM recommends connecting unused package pins to ground.
4. The exposed pad centered on the package bottom must be connected to RF, DC and thermal ground.

Ordering Information^{1,2}

Part Number	Package
MASW-011060-TR0500	500 piece reel
MASW-011060-SMB	Sample Board

1. Reference Application Note M513 for reel size information.
2. All sample boards include 5 loose parts.

*Restrictions on Hazardous Substances, European Union Directive 2011/65/EU.

Switch, SP2T 100 Watt Reflective 0.5 - 6.0 GHz

Rev. V1

Electrical Specifications: $T_A = 25^\circ\text{C}$, Bias = +5 / -5 V⁵, 50 mA / 100 mA

Parameter	Test Conditions	Units	Min.	Typ.	Max.
Insertion Loss $P_{IN} = 0$ dBm	0.5 GHz	dB	—	0.15	—
	1.0 GHz			0.25	—
	2.0 GHz			0.30	0.45
	3.0 GHz			0.35	—
	4.0 GHz			0.50	—
	5.0 GHz			0.75	—
	6.0 GHz			0.80	—
Isolation $P_{IN} = 0$ dBm	0.5 GHz	dB	—	47	—
	1.0 GHz		—	47	
	2.0 GHz		40	44	
	3.0 GHz		—	40	
	4.0 GHz		—	35	
	5.0 GHz		—	32	
	6.0 GHz		—	28	
Input Return Loss	$P_{IN} = 0$ dBm	dB	—	>15	—
CW Input Power ⁶	25°C Base plate, 2 GHz $V_{DC} = 0$ V / 28 V	dBm W	—	52 158	—
CW Input Power ⁶	85°C Base plate, 2 GHz $V_{DC} = 0$ V / 28 V	dBm W	—	50 100	—
P0.1dB ⁶	25°C Base plate, 2 GHz $V_{DC} = 0$ V / 28 V	dBm	—	52	—
Input IP3	F1 = 3000 MHz, F2 = 3010 MHz $P_{IN} = 40$ dBm/Tone, $V_{DC} = 0$ V / 28 V	dBm	—	75	—
T_{ON} , T_{OFF}	50% control to 90% RF, 50% control to 10% RF	μs	—	1.5	—
T_{RISE} , T_{FALL}	10% to 90% RF, 90% to 10% RF	μs	—	1.1	—

5. See Bias table and Application Schematic.

6. DC reverse bias of a PIN Diode operating at a high power is dependent on RF Frequency, Incident Power, and VSWR. See Minimum Reverse DC Voltage table for high power operation.

Absolute Maximum Ratings^{7,8}

Parameter	Absolute Maximum
Forward Current	150 mA
Reverse DC Voltage	-150 V
Operating Temperature	-40°C to +85°C
Storage Temperature	-55°C to +150°C
Junction Temperature	+175°C

7. Exceeding any one or combination of these limits may cause permanent damage to this device.

8. MACOM does not recommend sustained operation near these survivability limits.

Minimum Reverse DC Voltage⁹

Frequency (MHz)	Minimum Reverse DC Voltage
500	-41 V
1000	-22 V
2000	-11 V
3000	-8 V
4000	-6 V

9. Required to maintain low loss under 100 W of incident power with 1.5:1 VSWR.

Bias Tables for small signal operation

Positive / Negative DC Bias, +5 / -5 V

RF State	V1 Bias (V)	V2 Bias (V)	V3 Bias (V)	B1 Bias (V)	B2 Bias (V)
Pin No.	Pin 5	Pin 11	Pin 18	Pin 7	Pin 9
RFC – RF1 Insertion Loss RFC – RF2 Isolation	-5 V @ 100 mA	+5 V @ 50 mA	GND	GND	GND
RFC – RF2 Insertion Loss RFC – RF1 Isolation	+5 V @ 50 mA	-5 V @ 100 mA	GND	GND	GND

Positive Only DC Bias 0 / +10 V

RF State	V1 Bias (V)	V2 Bias (V)	V3 Bias (V)	B1 Bias (V)	B2 Bias (V)
Pin No.	Pin 5	Pin 11	Pin 18	Pin 7	Pin 9
RFC – RF1 Insertion Loss RFC – RF2 Isolation	0 V	+10 V @ 100 mA	+5 V @ 100 mA	+10 V @ 0 mA	0 V
RFC – RF2 Insertion Loss RFC – RF1 Isolation	+10 V @ 100 mA	0 V	+5 V @ 100 mA	0 V	+10 V @ 0 mA

Application Schematic

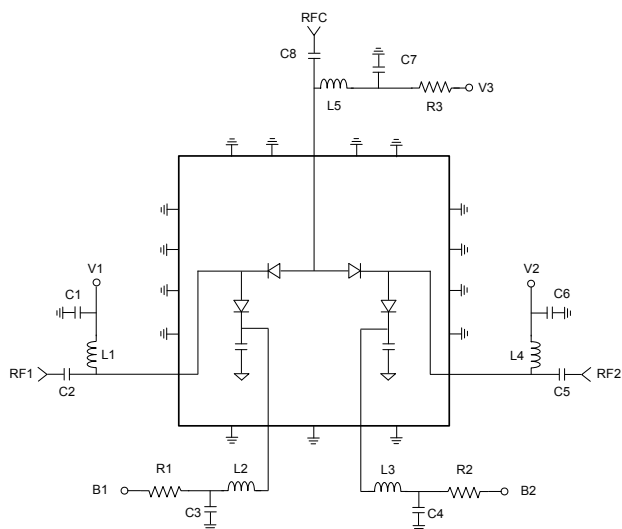

Off-Chip Component Values¹⁰

Component	Value	Size
C1, C3, C4, C6, C7	47 pF	0402
C2, C5, C8	18 pF	0402
L1 - L5	47 nH	0402
R1 - R2	82 Ω ¹¹	1210
R3	39 Ω	1210

10. Off-chip component values are used for small signal testing under +5 / -5 V and 0 / +10 V bias conditions. These must be rated appropriately to ensure safe performance under high power operation.

11. Shunt resistor (R1, R2) values can be adjusted using the following formula: $R = (V-1) / I_{SHUNT}$ where R is the shunt resistor value, V is the DC voltage applied to the reverse-biased series PIN diode, and I_{SHUNT} is the current through the forward-biased shunt PIN diode.

Typical Performance Curves: $T_A = 25^\circ\text{C}$, Bias = +5 / -5 V⁵, 50 mA / 100 mA

Insertion Loss

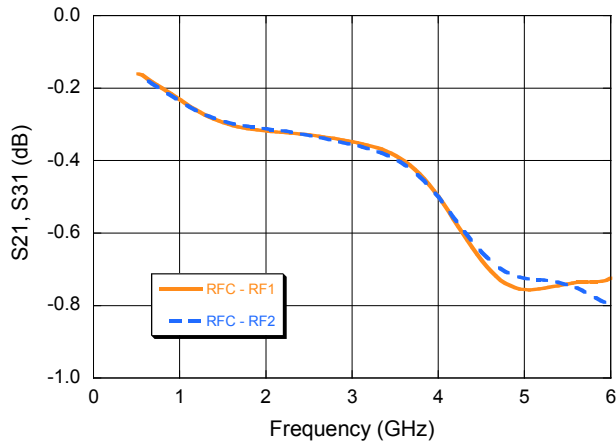

Isolation

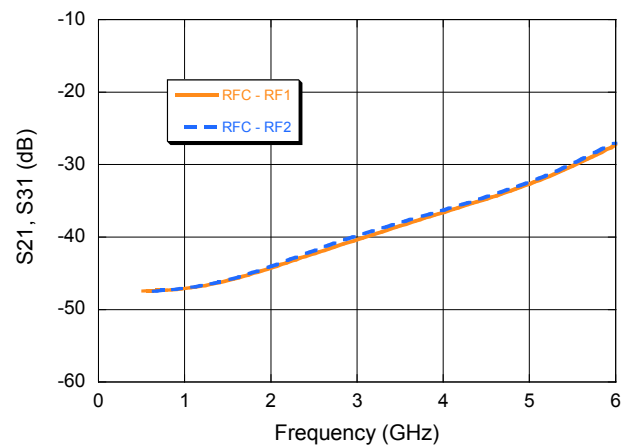

Input Return Loss

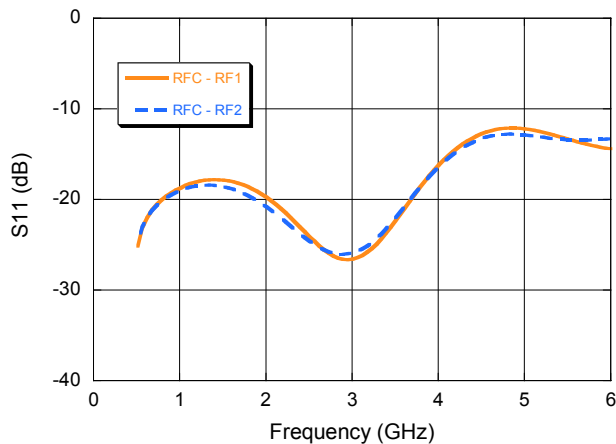

Output Return Loss

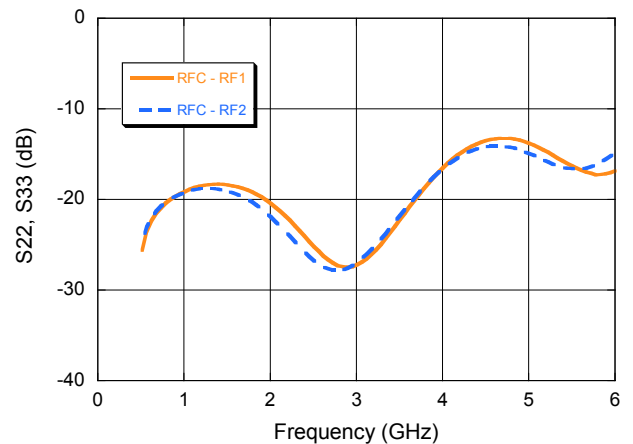

Switch, SP2T 100 Watt Reflective 0.5 - 6.0 GHz

Rev. V1

Large Signal Operation @ 1 GHz

Operation of the MASW-011060 high power switch requires four complementary DC control signals. Bias voltages are applied to DC ports B1 and V1 (corresponding to RF port RF1), B2 and V2 (corresponding to RF port RF2), and static V3.

For positive-only DC bias at 1 GHz, 5 V and 22 V are required. A constant 5 V is applied at the V3 DC port at all times. To set the switch to a RFC-RF1 low loss state and RFC-RF2 in Isolation, D1 PIN diode must be forward biased, D2 PIN diode must be reversed biased, D3 PIN diode must be forward biased, and D4 PIN diode must be reversed biased.

D1 PIN diode is forward biased by setting V1 port to 0 V. A 39 Ω resistor sets the forward current to a nominal of 100 mA. D2 PIN diode is reverse biased by applying 22 V at V2 port. This is the minimum reverse bias voltage that is required to maintain the PIN diode in its non-conducting, high impedance state under 100 W incident power with a 1.5:1 VSWR. D3 PIN diode is forward biased by setting B2 to 0 V. To determine the forward current of the shunt PIN diode, equation listed on note 10 can be used. The resultant resistance is 420 Ω to achieve 50 mA nominal forward current. D4 PIN diode is reverse biased by applying 22 V to B1 port.

To set the switch to a RFC-RF2 low loss state and RFC-RF1 in isolation, reverse 0 V and 22 V.

Large Signal Operation @ 1 GHz, DC Bias 0 / +22V

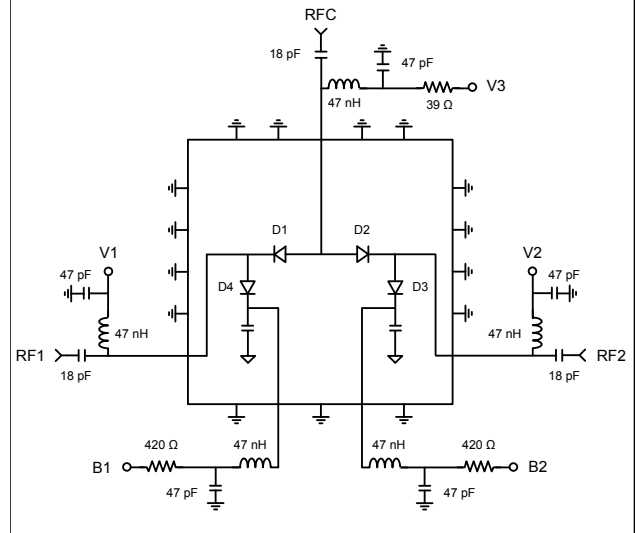

In order to safely operate at 100 W incident power, the values of the reactive components that make up the bias decoupling networks and DC blocking must be rated appropriately. Proper heat sinking is essential to safe operation under high incident power.

Bias 0 / +22 V (Large Signal Operation @ 1 GHz)

RF State	V1 Bias (V)	V2 Bias (V)	V3 Bias (V)	B1 Bias (V)	B2 Bias (V)
Pin No.	Pin 5	Pin 11	Pin 18	Pin 7	Pin 9
RFC - RF1 Insertion Loss RFC - RF2 Isolation	0 V	+22 V @ 50 mA	+5 V @ 100 mA	+22 V @ 0 mA	0 V
RFC - RF2 Insertion Loss RFC - RF1 Isolation	+22 V @ 50 mA	0 V	+5 V @ 100 mA	0 V	+22 V @ 0 mA

Lead Free 4 mm 20-Lead HQFN †

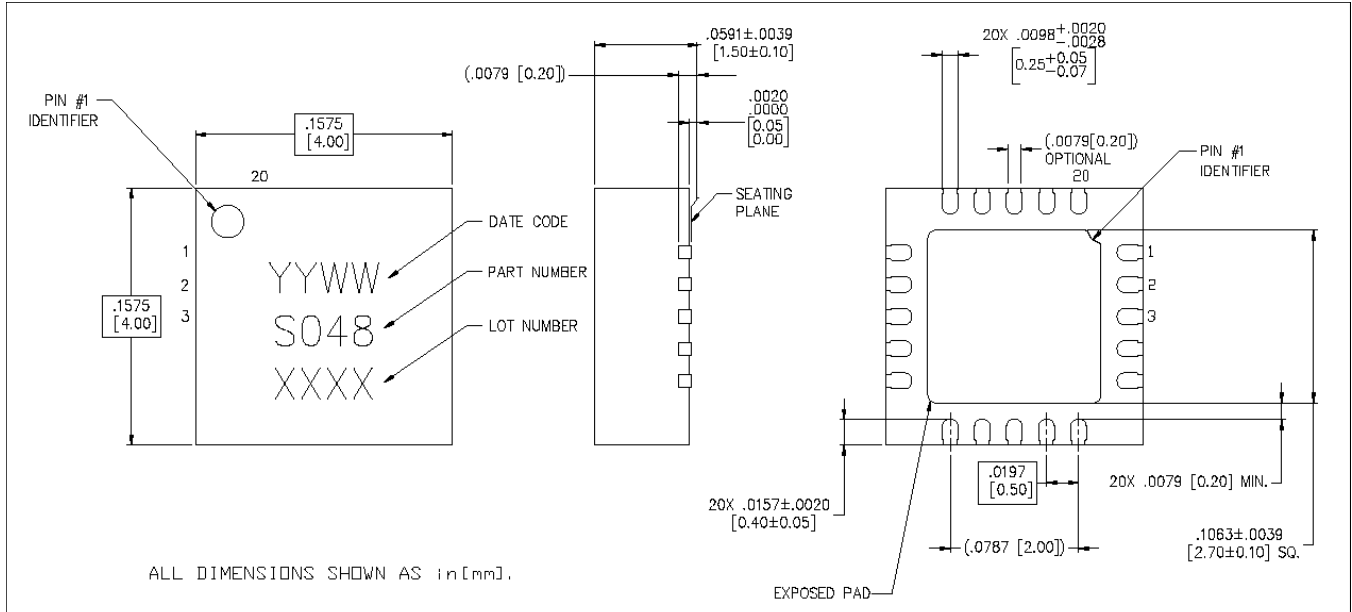

† Reference Application Note S2083 for lead-free solder reflow recommendations.
Meets JEDEC moisture sensitivity level 1 requirements.
Plating is NiPdAuAg.

Handling Procedures

Please observe the following precautions to avoid damage:

Static Sensitivity

These electronic devices are sensitive to electrostatic discharge (ESD) and can be damaged by static electricity. Proper ESD control techniques should be used when handling these Class 1B HMB devices.

M/A-COM Technology Solutions Inc. All rights reserved.

Information in this document is provided in connection with M/A-COM Technology Solutions Inc ("MACOM") products. These materials are provided by MACOM as a service to its customers and may be used for informational purposes only. Except as provided in MACOM's Terms and Conditions of Sale for such products or in any separate agreement related to this document, MACOM assumes no liability whatsoever. MACOM assumes no responsibility for errors or omissions in these materials. MACOM may make changes to specifications and product descriptions at any time, without notice. MACOM makes no commitment to update the information and shall have no responsibility whatsoever for conflicts or incompatibilities arising from future changes to its specifications and product descriptions. No license, express or implied, by estoppel or otherwise, to any intellectual property rights is granted by this document.

THESE MATERIALS ARE PROVIDED "AS IS" WITHOUT WARRANTY OF ANY KIND, EITHER EXPRESS OR IMPLIED, RELATING TO SALE AND/OR USE OF MACOM PRODUCTS INCLUDING LIABILITY OR WARRANTIES RELATING TO FITNESS FOR A PARTICULAR PURPOSE, CONSEQUENTIAL OR INCIDENTAL DAMAGES, MERCHANTABILITY, OR INFRINGEMENT OF ANY PATENT, COPYRIGHT OR OTHER INTELLECTUAL PROPERTY RIGHT. MACOM FURTHER DOES NOT WARRANT THE ACCURACY OR COMPLETENESS OF THE INFORMATION, TEXT, GRAPHICS OR OTHER ITEMS CONTAINED WITHIN THESE MATERIALS. MACOM SHALL NOT BE LIABLE FOR ANY SPECIAL, INDIRECT, INCIDENTAL, OR CONSEQUENTIAL DAMAGES, INCLUDING WITHOUT LIMITATION, LOST REVENUES OR LOST PROFITS, WHICH MAY RESULT FROM THE USE OF THESE MATERIALS.

MACOM products are not intended for use in medical, lifesaving or life sustaining applications. MACOM customers using or selling MACOM products for use in such applications do so at their own risk and agree to fully indemnify MACOM for any damages resulting from such improper use or sale.

Данный компонент на территории Российской Федерации

Вы можете приобрести в компании MosChip.

Для оперативного оформления запроса Вам необходимо перейти по данной ссылке:

<http://moschip.ru/get-element>

Вы можете разместить у нас заказ для любого Вашего проекта, будь то серийное производство или разработка единичного прибора.

В нашем ассортименте представлены ведущие мировые производители активных и пассивных электронных компонентов.

Нашей специализацией является поставка электронной компонентной базы двойного назначения, продукции таких производителей как XILINX, Intel (ex.ALTERA), Vicor, Microchip, Texas Instruments, Analog Devices, Mini-Circuits, Amphenol, Glenair.

Сотрудничество с глобальными дистрибьюторами электронных компонентов, предоставляет возможность заказывать и получать с международных складов практически любой перечень компонентов в оптимальные для Вас сроки.

На всех этапах разработки и производства наши партнеры могут получить квалифицированную поддержку опытных инженеров.

Система менеджмента качества компании отвечает требованиям в соответствии с ГОСТ Р ИСО 9001, ГОСТ РВ 0015-002 и ЭС РД 009

Офис по работе с юридическими лицами:

105318, г.Москва, ул.Щербаковская д.3, офис 1107, 1118, ДЦ «Щербаковский»

Телефон: +7 495 668-12-70 (многоканальный)

Факс: +7 495 668-12-70 (доб.304)

E-mail: info@moschip.ru

Skype отдела продаж:

moschip.ru

moschip.ru_4

moschip.ru_6

moschip.ru_9