

75 W digitally controlled constant current LED driver reference design

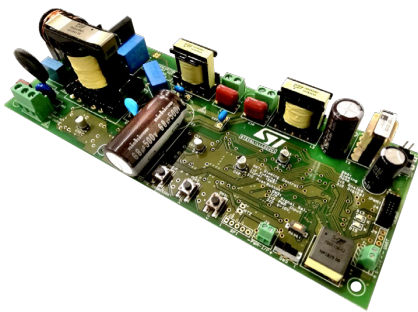

Features

- Wide input voltage range 85 – 265 V_{AC}
- Transition Mode PFC
- Two constant current outputs working in transition mode based on different topologies:
 - Buck topology
 - Inverse buck topology
- Output current: 500 mA ±2.5%
 - Number of LEDs connected at output: 16 – 24 white LEDs (3.3 V each)
- PFC > 0.97 and THD < 20% at full load with input voltage 85-265 V_{AC}
- Peak Efficiency at maximum load ≅ 90%
- Comprehensive safety protections:
 - Open/no-load circuit protection
 - Short-/overload circuit protection
- Soft start implementation
- LED dimming range: 0.5% to 100%
 - Analog dimming
 - Digital dimming
- Dimming control options:
 - Push button
 - 0-10 V input
- Meets EN55022 Class B
- WEEE and RoHS compliant

Summary table	
STEVAL-LLL004V1 evaluation board	STEVAL-LLL004V1
Mainstream ARM Cortex-M0 Access line MCU with 128 Kbytes Flash, 48 MHz CPU and CEC functions	STM32F071CBT6
N-channel 600 V, 0.550 Ω typ., 7.5 A MDmesh M2 EP Power MOSFET in a DPAK package	STD11N60M2-EP
VIPerPlus family: Low voltage energy saving fixed frequency high voltage converter	VIPER012LS

Description

The **STEVAL-LLL004V1** digitally controlled constant current LED driver reference design features a PFC stage and two DC-DC converters designed to work in transition mode (TM) for optimal efficiency.

The LED driver can deliver 75 W output power and implements both analog and digital techniques for flicker free dimming down to 0.5% of the maximum brightness level. The board features high efficiency, a very high power factor above 0.97, and a low THD across wide input voltage and load conditions, thanks to the high performance ST power products and the advanced algorithms running on the 32-bit STM32F0 microcontroller.

1 LED driver reference design overview

The principal design objectives of this LED driver board are to deliver considerable performance in terms of efficiency (90%), power factor (>0.97), THD (<20%), wide dimming range (down to 0.5%) and EN55022 EMC pre-compliance, as well as facilitate design optimization over a wide range of operating points with little or no hardware configuration. A reference design based on digital algorithms supported by a programmable STM32 microcontroller therefore seemed to be the ideal solution.

The implementation of digital control as opposed to analog is gaining popularity in power conversion circles for its superior flexibility regarding control loop parameter and on-the-fly operating point adjustment for any given condition, without needing to modify the hardware. Additionally, digital control ensures greater stability under noisy conditions and tends to be less sensitive to component tolerances, temperature variations and voltage drift. An appropriate programmable digital controller can also simplify the implementation and customization of advanced lighting solution features like flicker-free, high-resolution dimming, connectivity for remote control and dimming, diagnostic protection and monitoring.

Figure 1. STEVAL-LLL004V1 block diagram

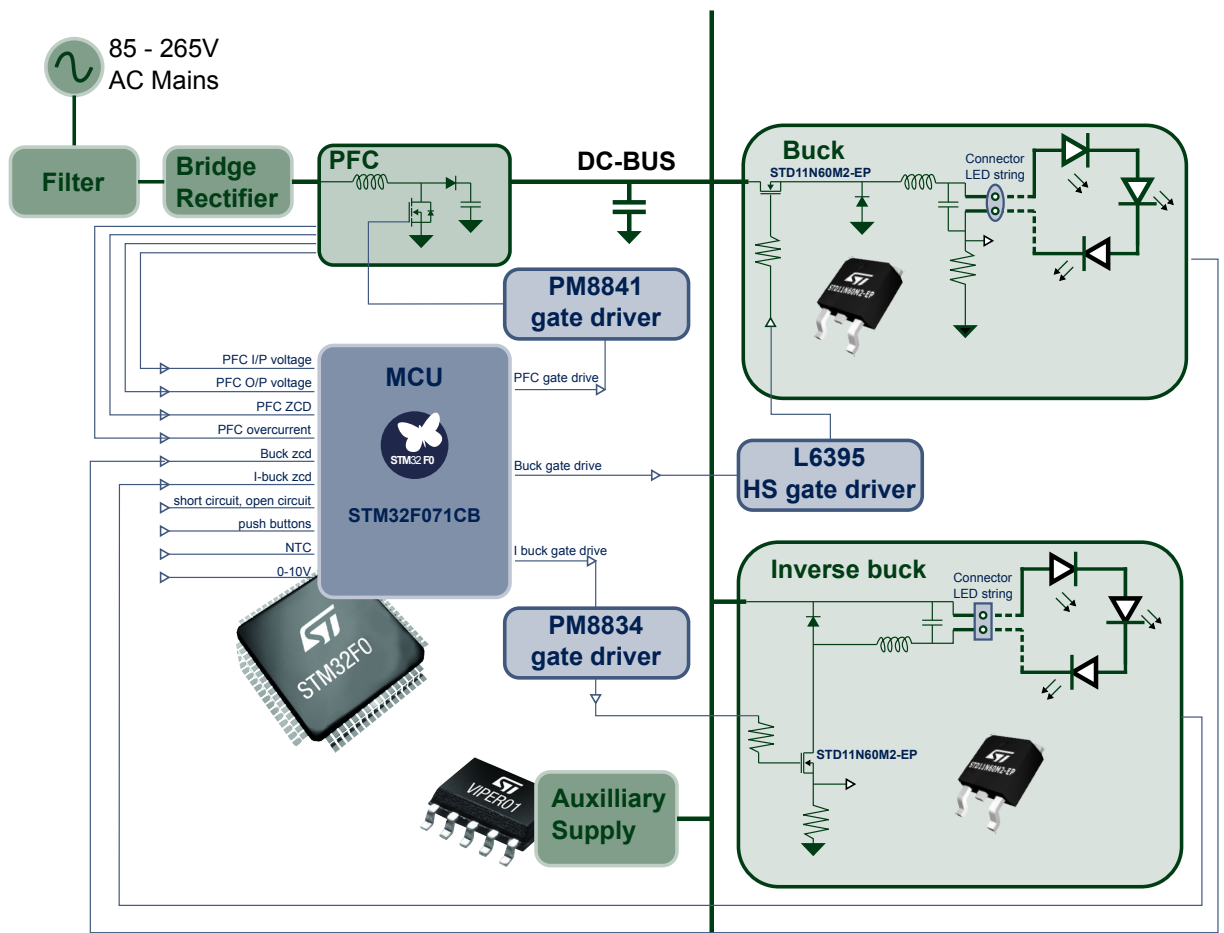

The digital controller chosen for the STEVAL-LLL004V1 LED driver reference design is the STM32F071CB microcontroller featuring a generous set of hardware peripherals. The MCU controls the PFC, the buck and inverse-buck DC-DC power conversion stages in transition mode (TM), which maximizes efficiency by turning the Power MOSFET switch ON as the current in the inductor reaches zero, and implements both analog and digital dimming. The advanced control timer (TIMER1) in STM32F071CB can work together with the other timers via the Timer Link feature for synchronization or event chaining, simplifying the task of the designer.

The PFC provides a regulated high-voltage DC rail and ensures that the current drawn from the mains is highly sinusoidal and in phase with mains voltage. A proportional-integral (PI) control loop is included in the PFC stage

to improve control loop stability, line transition and dimming step behavior, while reducing current and voltage overshoot at start-up.

The board is designed to allow evaluation of the advantages and disadvantages of buck and modified buck (Inverse buck) DC-DC conversion topologies by implementing both converters in parallel: the modified buck topology has the power switch connected to ground, rendering it is easier to control the switch, while the buck converter has the LEDs connected to the ground.

The N-Channel 600 V MDmesh™ M2 [STD11N60M2-EP](#) MOSFET is also a key design choice as it is tailored for optimal performance under light load conditions, which is desirable in dimming applications, while its DPAK package helps maintain a slim profile in commercial solutions.

The HV converter VIPer01 is selected for the auxiliary SMPS thanks to its low V_{CC} supply voltage to minimize power consumption, especially at light load. It is used in a non-isolated flyback topology with direct output feedback thanks to the embedded error amplifier in order to save BOM components without affecting regulation performance.

2 STEVAL-LLL004V1 schematic diagrams

Figure 2. STEVAL-LLL004V1 schematic - PFC converter

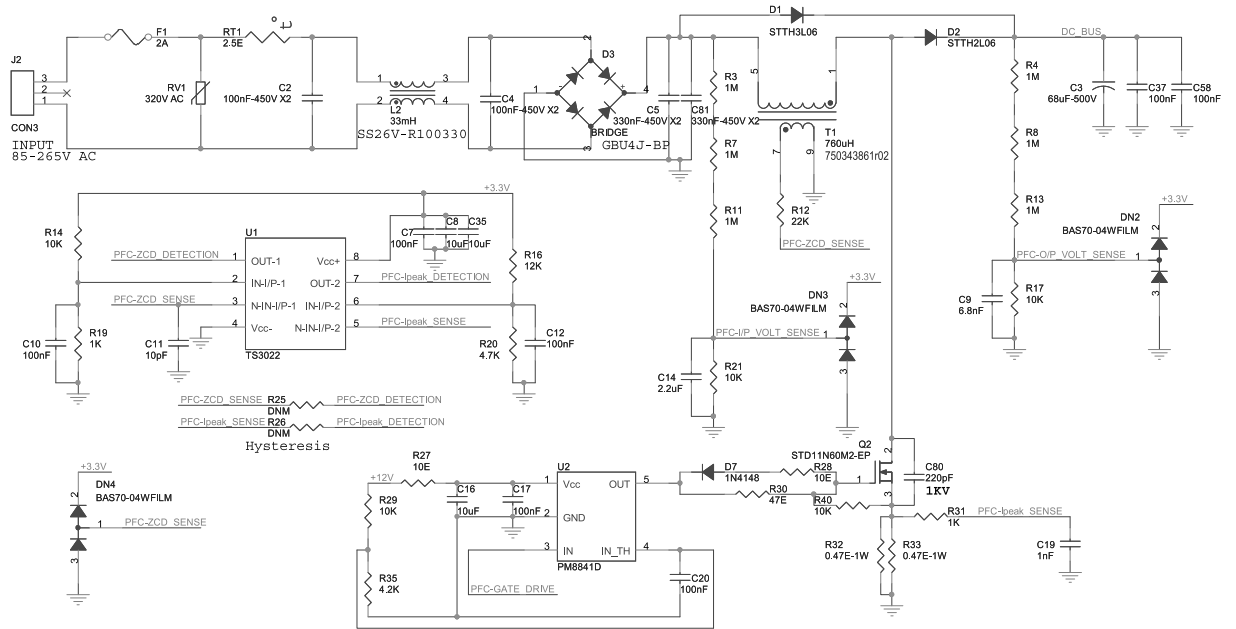

Figure 3. STEVAL-LLL004V1 schematic - inverse buck converter

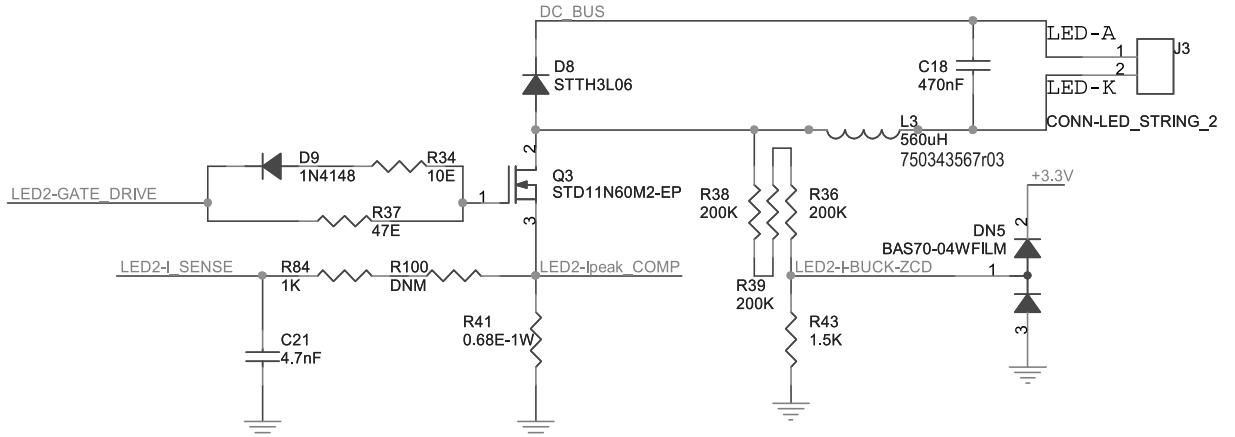

Figure 4. STEVAL-LLL004V1 schematic - buck converter

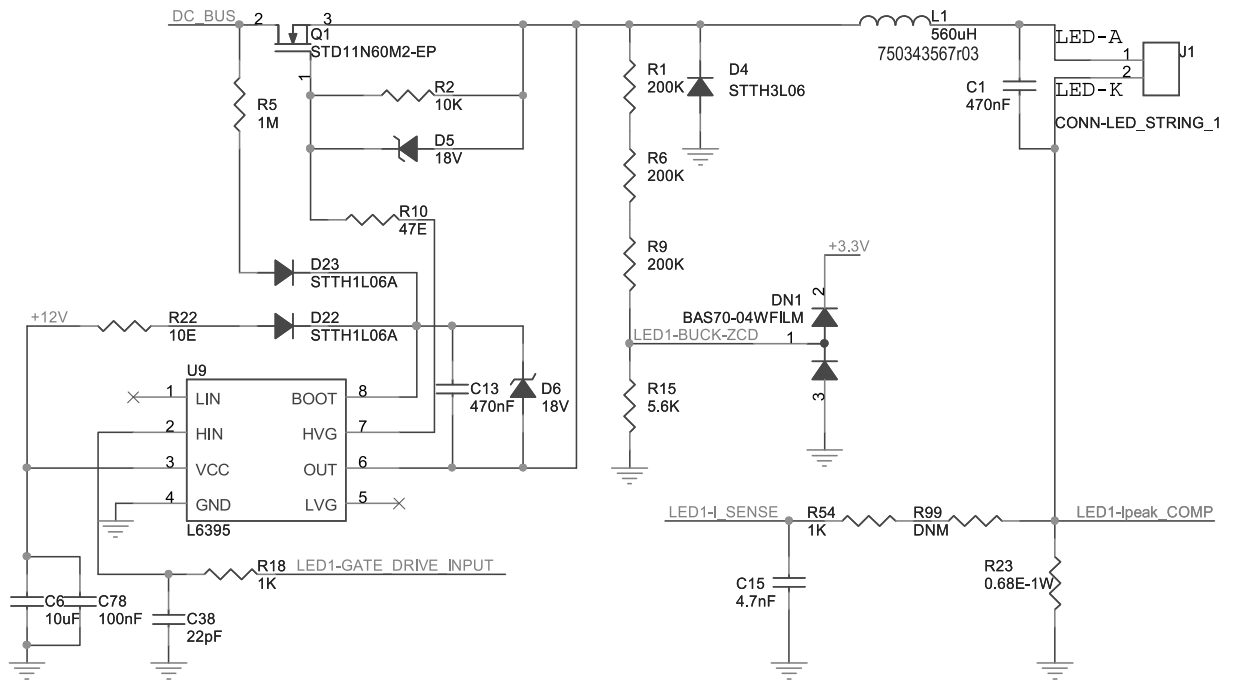

Figure 5. STEVAL-LLL004V1 schematic - auxiliary power supply

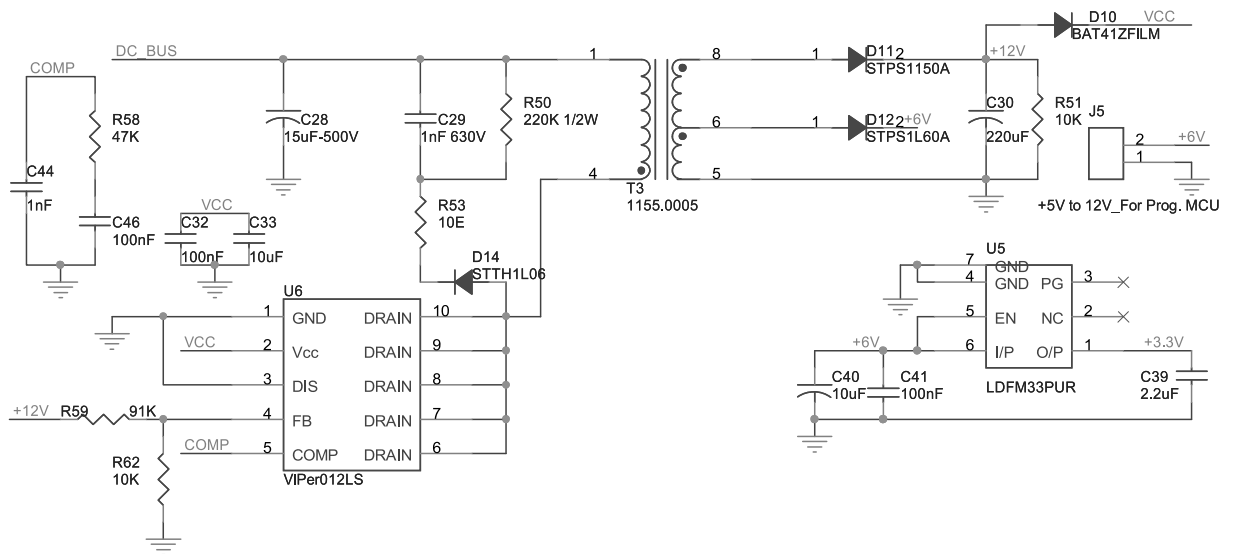

Figure 6. STEVAL-LLL004V1 schematic - STM32 microcontroller

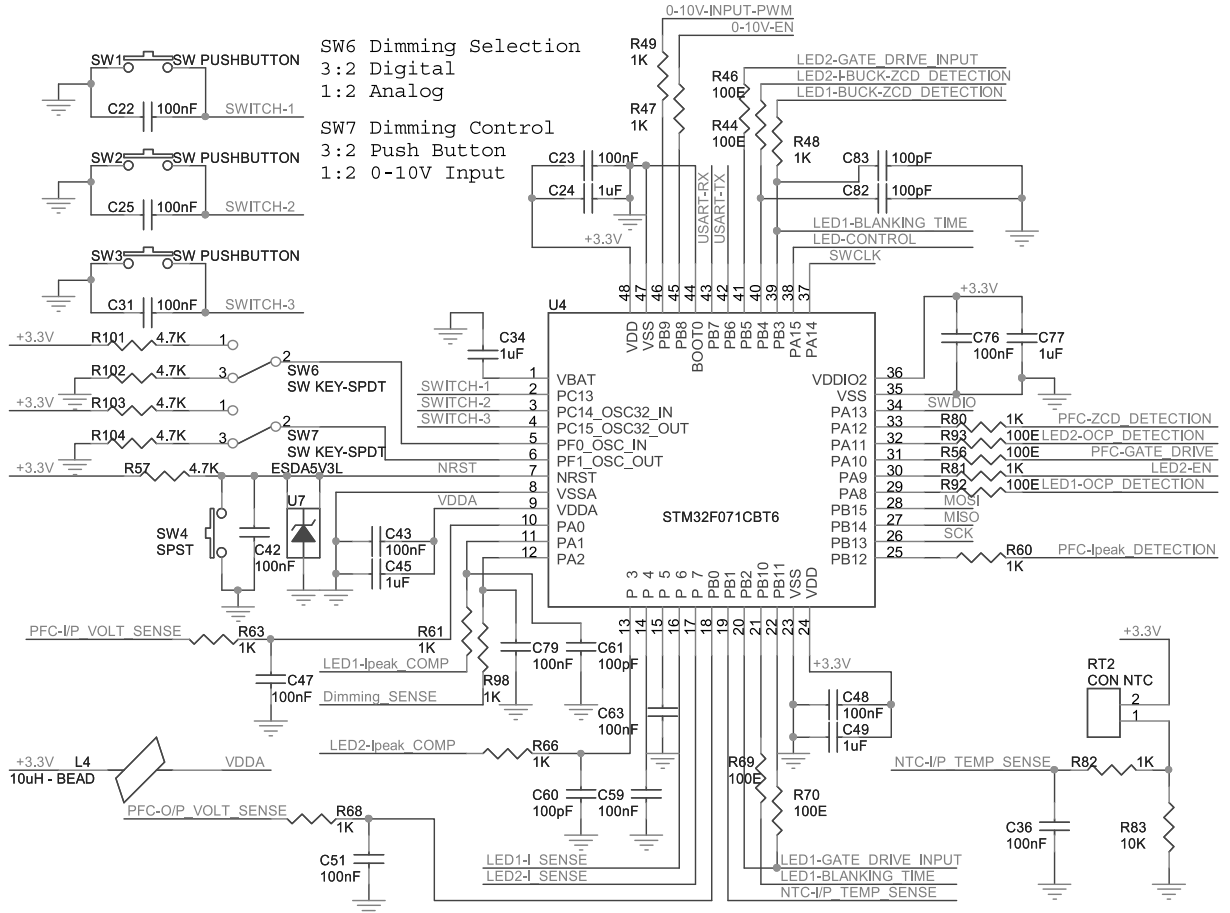
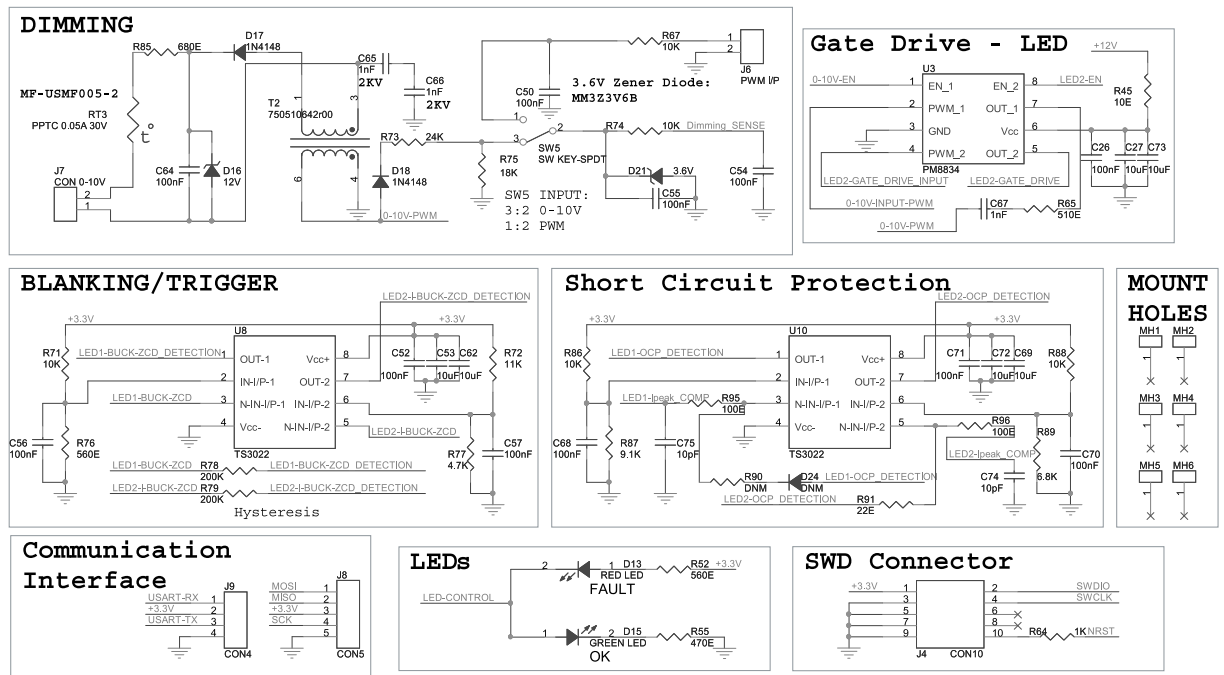

Figure 7. STEVAL-LLL004V1 schematic - miscellaneous



Revision history

Table 1. Document revision history

Date	Version	Changes
29-Nov-2018	1	Initial release.
25-Jul-2019	2	Updated document title Updated and renamed (was <i>STEVAL-LLL004V1 block diagram</i>) Section 1 LED driver reference design overview , with information regarding design choices. Minor text edits throughout document

IMPORTANT NOTICE – PLEASE READ CAREFULLY

STMicroelectronics NV and its subsidiaries (“ST”) reserve the right to make changes, corrections, enhancements, modifications, and improvements to ST products and/or to this document at any time without notice. Purchasers should obtain the latest relevant information on ST products before placing orders. ST products are sold pursuant to ST’s terms and conditions of sale in place at the time of order acknowledgement.

Purchasers are solely responsible for the choice, selection, and use of ST products and ST assumes no liability for application assistance or the design of Purchasers’ products.

No license, express or implied, to any intellectual property right is granted by ST herein.

Resale of ST products with provisions different from the information set forth herein shall void any warranty granted by ST for such product.

ST and the ST logo are trademarks of ST. For additional information about ST trademarks, please refer to www.st.com/trademarks. All other product or service names are the property of their respective owners.

Information in this document supersedes and replaces information previously supplied in any prior versions of this document.

© 2019 STMicroelectronics – All rights reserved

Данный компонент на территории Российской Федерации

Вы можете приобрести в компании MosChip.

Для оперативного оформления запроса Вам необходимо перейти по данной ссылке:

<http://moschip.ru/get-element>

Вы можете разместить у нас заказ для любого Вашего проекта, будь то серийное производство или разработка единичного прибора.

В нашем ассортименте представлены ведущие мировые производители активных и пассивных электронных компонентов.

Нашей специализацией является поставка электронной компонентной базы двойного назначения, продукции таких производителей как XILINX, Intel (ex.ALTERA), Vicor, Microchip, Texas Instruments, Analog Devices, Mini-Circuits, Amphenol, Glenair.

Сотрудничество с глобальными дистрибьюторами электронных компонентов, предоставляет возможность заказывать и получать с международных складов практически любой перечень компонентов в оптимальные для Вас сроки.

На всех этапах разработки и производства наши партнеры могут получить квалифицированную поддержку опытных инженеров.

Система менеджмента качества компании отвечает требованиям в соответствии с ГОСТ Р ИСО 9001, ГОСТ РВ 0015-002 и ЭС РД 009

Офис по работе с юридическими лицами:

105318, г.Москва, ул.Щербаковская д.3, офис 1107, 1118, ДЦ «Щербаковский»

Телефон: +7 495 668-12-70 (многоканальный)

Факс: +7 495 668-12-70 (доб.304)

E-mail: info@moschip.ru

Skype отдела продаж:

moschip.ru

moschip.ru_4

moschip.ru_6

moschip.ru_9