

## Sound Processor Series for Car Audio

# 6ch Electronic Volume for 5.1ch Car Theater



BD3433K

No.10085EAT01

### ●Description

The 6ch electronic volume for 5.1ch car theater is an electronic volume device incorporating 6ch input selector (front/rear independently-controlled), input gain amp (front/rear independently-controlled), 6ch independently-controlled electronic volume (capable of soft switching), 6ch output gain amp (2-line outputs), differential input for monophonic signals, electronic volume for monophonic signals (capable of soft switching), and mixing circuit for monophonic signals. It is provided with the high performance functions to achieve low distortion and low noise and, furthermore, to output the 5.6Vrms high voltage. The QFP44 package which realizes savings in space and components is used to be suited for applications such as car audio and car navigation.

### ●Features

- 1) High voltage output of 5.6Vrms achieved  
Provided with 2 lines of outputs to the built-in power amp and the pre-out
- 2) Volume switching noise is reduced by installing the advanced 6ch independently-controlled electronic volume with soft switching.
- 3) High performance capabilities such as low distortion rate (0.001%), low noise (3 $\mu$ Vrms)
- 4) Different signals from the different sources can be outputted to the front and rear sections independently and this provides an option of rear-seat entertainment.
- 5) Incorporate the monophonic differential input circuit suited for inputting navigation voice and telephone speech. These monophonic voices can be mixed with the front output signals.
- 6) Adopting the Bi-CMOS process achieves low current consumption, which contributes to energy-saving design. It has the advantage in quality over scaling down and heat reduction of the internal regulators.
- 7) 3-wire serial interface supported for both of 3.3V and 5V microcomputers

### ●Applications

For car audio equipment, car navigation equipment, and hybrid systems.

● **Absolute maximum ratings**( $T_a=25^\circ\text{C}$ )

Item	Symbol	Terminal	Rating	Unit
Terminal applied voltage	VCC-GND	※1	10	V
	VEE-GND	※1	-10	
	VLGC	Control terminal (CS/SCK/SDA) ※1	5.5	
Power dissipation	Pd	※2	850	mW
Operating Temperature	Topr		-40 ~ +85	°C
Storage Temperature	Tastg		-55 ~ +125	°C

※1 : Maximum applied voltage based on GND.

※2 : Derating is done 8.5mW/°C for  $T_a > 25^\circ\text{C}$ .

Mounted on (Material: FR4 glass epoxy board (beaten-copper area <3%), size:70mm × 70mm × 1.6mm)

※3 : No radiation-proof design

● **Operating conditions** (Operating condition at  $T_a=25^\circ\text{C}$ )

Item	Symbol	Terminal	Condition	MIN	TYP	MAX	Unit
Operating power supply voltage	VCC	VCC-GND	※1	7.0	9	9.5	V
	VEE	VEE-GND		-9.5	-9	-7.0	V

※1 : When it is within operating temperature, basic circuit function is guaranteed within operating voltage. However, setting constant and element, voltage setting, and temperature setting are required when in operation. Other than the condition stipulated within the range, the standard value of electrical characteristics could not be guaranteed, while original function is retained.

● **Electrical characteristics**

Abbreviations :

“**Giaj**” : Setting value of Input gain adjustor

“**Vol.Ex**” : Setting value of volume for monaural signal

“**Goajb**” : Setting value of output gain adjustor B

“**Vol**” : Setting value of volume (1~6ch)

“**Goaja**” : Setting value of output gain adjustor A

“**Mix**” : ON/OFF setting for mixing switch.

Measurement condition (Unless specified particularly) :

$T_a=25^\circ\text{C}$ , VCC=9V, VEE=-9V,  $V_{in}=1V_{rms}/1\text{kHz}$ , Load resistance=10k $\Omega$ , Load capacitance=10pF, Giaj=0dB, Vol=0dB, Goaja=0dB, Goajb=0dB, Vol.Ex=-∞dB, Mix=OFF

■ **General characteristics**

Item	Symbol	Condition	MIN	TYP	MAX	Unit
Current consumption	ICC		-	10	17	mA
	IEE		-17	-9	-	
VCO oscillation frequency	Fvco		-	400	-	kHz
Ripple rejection	RRc	Ripple = 0.1Vrms/ 1kHz (Input terminal AC short)	40	85	-	dB
	RRe	Ripple= 0.1Vrms/ 1kHz (Input terminal AC short)	30	70	-	dB
Reset operation voltage	VRS	Initialize all register data by $V_{cc} < VRS \rightarrow V_{cc} > VRS$	-	3.4	-	V
Required time for Power on reset	TPOR	Minimum required time to reach 3V after Vcc voltage ON.	20	-	-	$\mu\text{sec}$

■ Logic circuit

Item	Symbol	Terminal	MIN	TYP	MAX	Unit
"H" level input voltage	VIH	CS, SCK, SDA	2.3	-	5.5	V
"L" level input voltage	VIL	CS, SCK, SDA	0	-	1.0	V
Input clock frequency	f <sub>SCK</sub>	SCK	-	-	1.5	MHz

■ Volume circuit

Item	Symbol	Condition	MIN	TYP	MAX	Unit	
Voltage gain	GV		-1	0	1	dB	
Bandwidth	FW	Frequency, which drop -1dB towards 1kHz	100	-	-	kHz	
Slew rate	SR		-	1.65	-	V/μsec	
Maximum input voltage	VIM	THD+N = 1% , Vol = -10dB	3.8	4.25	-	Vrms	
Maximum output voltage	VOM1	THD+N = 1% Vol = +10dB	3.8	4.25	-	Vrms	
	VOM2		Goaja=+2.5dB	5	5.6		-
	VOM3		Goajb=-4.5dB	2.2	2.5		-
Input impedance	RI		70k	100k	130k	Ω	
Output impedance	RO		-	-	50	Ω	
Input gain setting value error	EGI	Output reference is Giaj=0dB Giaj=6, 12 dB, Vin=0.1Vrms	-1	0	1	dB	
Volume setting value error	EV1	Vol=0dB Output standard	Vol=+23~+1, -1~-20dB (+23~+1dB at Vin=0.1Vrms)	-1.0	0	1.0	dB
	EV2		Vol=-21~-40dB	-1.5	0	1.5	
	EV3		Vol=-41~-60dB	-2.0	0	2.0	
	EV4		Vol=-61~-79dB	-3.0	0	3.0	
Volume maximum attenuation	VMU	Vol=-∞dB (mute) , BW=20~20kHz	-	-108	-85	dB	
Output gain setting value error	EGOA	Goaja=0dB Goajb=0dB Output standard	Goaja=+2.5dB	-1	0	1	dB
	EGOB		Goajb=-4.5dB	-1	0	1	
Gain balance between channels	CB		-1	0	1	dB	
Cross-talk between channels	CTC	BW=20~20kHz (Input terminal AC short)	85	106	-	dB	
Output noise voltage	VNO	BW=A-Weight (Input terminal AC short)	Vol=0dB	-	2.5	10	μVrms
Residual output noise voltage	VNR		Vol=-∞dB	-	2	10	
THD+N	THD	BW=20~20kHz, Vout=1Vrms	-	0.001	0.05	%	
Soft switching transition time	Tss1	Soft switching:ON	0.64 msec/dB	-	0.64	-	msec /dB
	Tss2		1.28 msec/dB	-	1.28	-	
	Tss3		2.56 msec/dB	-	2.56	-	
	Tss4		5.12 msec/dB	-	5.12	-	

■ Monaural signal circuit

Common condition unless specified particularly :

Vol=-∞dB, Giaj=Goaja= Goajb=0dB, Vol.Ex=0dB, Mix=ON

Item	Symbol	Condition	MIN	TYP	MAX	Unit	
Voltage gain	GVe	Phase inversion between input and output	-1.0	0	1.0	dB	
Maximum input voltage	VIMe	THD+N=1%, Vol.Ex=-10dB	3.8	4.25	-	Vrms	
Input impedance	Rle		19	27	35	kΩ	
Volume setting value error	EVe1	Vol.Ex=0dB Output standard Vol=+15~+1, -1~-20dB (+15~+1dB at Vin=0.1Vrms)	-1.0	0	1.0	dB	
	EVe2		-1.5	0	1.5		
	EVe3		-2.0	0	2.0		
	EVe4		-3.0	0	3.0		
Volume maximum attenuation	VMUe	Vol.Ex=-∞dB (mute) , BW=20~20kHz	-	-108	-85	dB	
Output noise voltage	VNOe	BW=A-Weight (Input terminal AC short)	Vol.Ex = 0dB		-	4.5	μVrms
Residual noise voltage	VNRe		Vol.Ex = -∞dB		-	3.5	
THD+N	THDe	BW=20~20kHz, Vout=1Vrms	-	0.002	0.05	%	
Common-mode signal rejection ratio	CMRR	BW=20~20kHz	40	60	-	dB	
Soft switching transition time	Tsse1	Soft switching:ON	0.64 msec/dB		-	0.64	msec /dB
	Tsse2		1.28 msec/dB		-	1.28	
	Tsse3		2.56 msec/dB		-	2.56	
	Tsse4		5.12 msec/dB		-	5.12	

●Timing chart

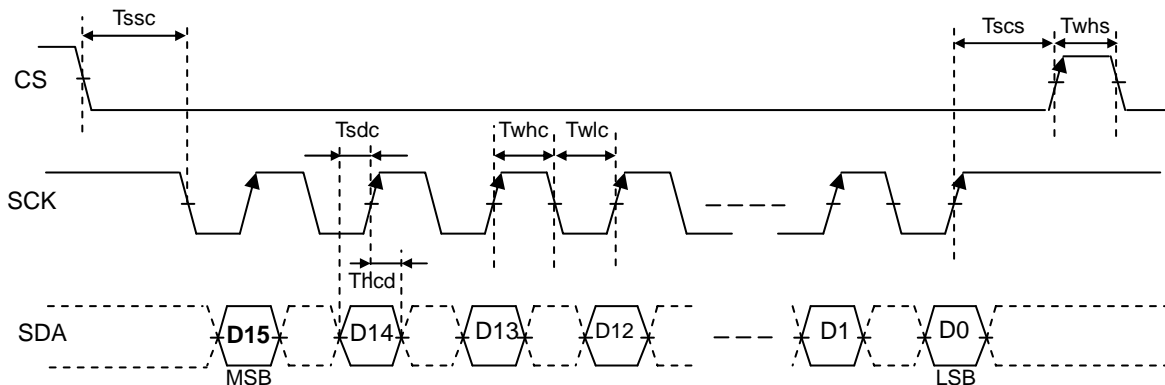

- When CS is “Low”, enable micro computer control data (SCK/SDA). (It doesn't work, when it is “High”),
- Data (SDA) reads at a leading edge of clock (SCK).
- Latch reads at a leading edge of CS. (SCK has to be kept as “High” after D0 acquisition)

## ● External Dimension

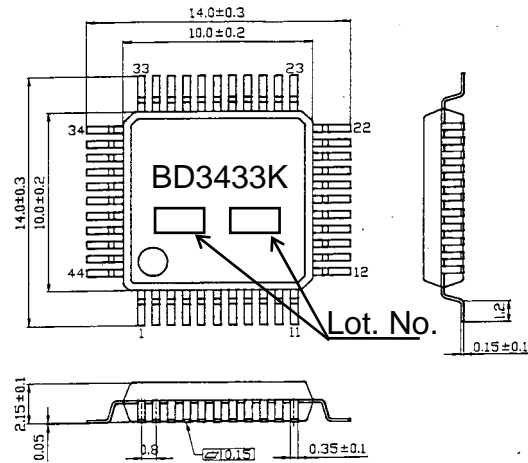

QFP44 (Unit : mm)

## ● Terminal Number, Terminal name:

Terminal Number	Terminal name	Terminal Number	Terminal name	Terminal Number	Terminal name	Terminal Number	Terminal name
1	AGNDE	12	INBFR	23	OUTAFR	34	DGND
2	INAFI	13	AGND4	24	OUTAC	35	SDA
3	INAFR	14	INBC	25	OUTASW	36	SCK
4	AGND1	15	INBSW	26	OUTARL	37	CS
5	INAC	16	AGND5	27	OUTARR	38	TEST
6	INASW	17	INBRL	28	OUTBFL	39	ADJ
7	AGND2	18	INBRR	29	OUTBFR	40	VEE
8	INARL	19	AGND6	30	OUTBC	41	AGNDM
9	INARR	20	SOUTRL	31	OUTBSW	42	VCC
10	AGND3	21	SOUTRR	32	OUTBRL	43	INEX+
11	INBFL	22	OUTAFL	33	OUTBRR	44	INEX-

●Block diagram

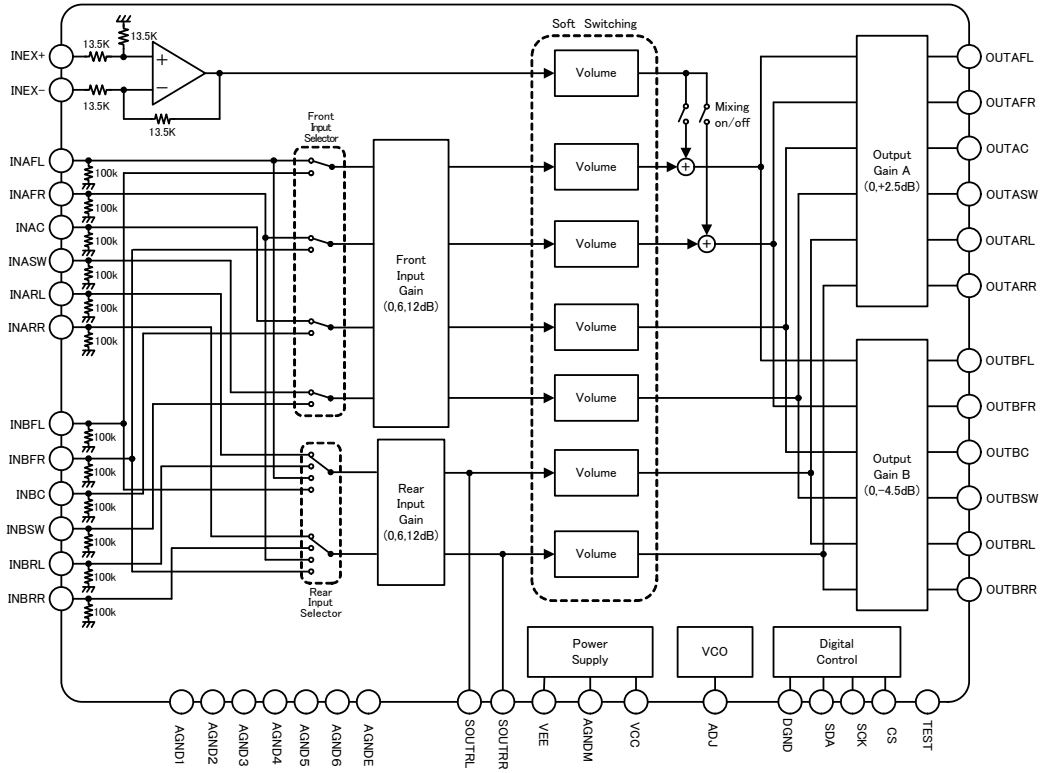

**●Notes for use**

## 1. Absolute Maximum Ratings;

It may cause failure if operation is beyond absolute maximum ratings of applied voltage or operating temperature. In case of failure, it is not possible to set short mode or open mode. If particular mode requires beyond absolute maximum ratings, please take a physical safety measure.

## 2. VEE electrical potential

Please minimize electrical potential of VEE terminal under any operational condition.

## 3. Thermal design

Please consider power dissipation (Pd) on actual operational condition and provide enough margins for thermal design.

## 4. Operation in intense electric field

Please note that malfunction may occur if operation is under intense electric field.

● Ordering part number

B	D
---	---

Part No.

3	4	3	3
---	---	---	---

Part No.

K
---

Package  
K: QFP44

-

E	2
---	---

Packaging and forming specification  
E2: Embossed tape and reel

QFP44

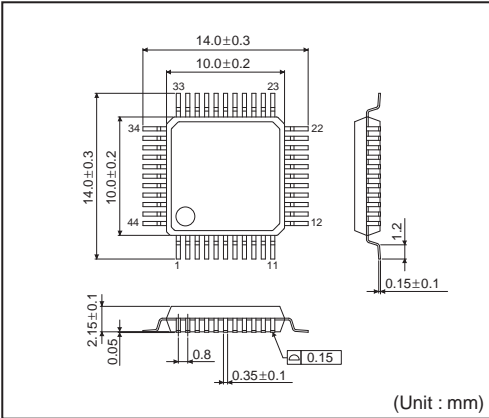

<Tape and Reel information>

Tape	Embossed carrier tape
Quantity	1000pcs
Direction of feed	E2 ( The direction is the 1 pin of product is at the upper left when you hold reel on the left hand and you pull out the tape on the right hand )

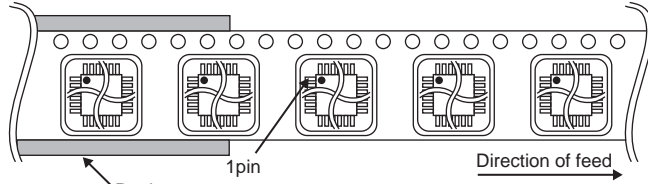

\*Order quantity needs to be multiple of the minimum quantity.



# Notice

## Precaution on using ROHM Products

- Our Products are designed and manufactured for application in ordinary electronic equipments (such as AV equipment, OA equipment, telecommunication equipment, home electronic appliances, amusement equipment, etc.). If you intend to use our Products in devices requiring extremely high reliability (such as medical equipment <sup>(Note 1)</sup>, transport equipment, traffic equipment, aircraft/spacecraft, nuclear power controllers, fuel controllers, car equipment including car accessories, safety devices, etc.) and whose malfunction or failure may cause loss of human life, bodily injury or serious damage to property ("Specific Applications"), please consult with the ROHM sales representative in advance. Unless otherwise agreed in writing by ROHM in advance, ROHM shall not be in any way responsible or liable for any damages, expenses or losses incurred by you or third parties arising from the use of any ROHM's Products for Specific Applications.

(Note1) Medical Equipment Classification of the Specific Applications

JAPAN	USA	EU	CHINA
CLASS III	CLASS III	CLASS II b	CLASS III
CLASS IV		CLASS III	

- ROHM designs and manufactures its Products subject to strict quality control system. However, semiconductor products can fail or malfunction at a certain rate. Please be sure to implement, at your own responsibilities, adequate safety measures including but not limited to fail-safe design against the physical injury, damage to any property, which a failure or malfunction of our Products may cause. The following are examples of safety measures:
  - Installation of protection circuits or other protective devices to improve system safety
  - Installation of redundant circuits to reduce the impact of single or multiple circuit failure
- Our Products are designed and manufactured for use under standard conditions and not under any special or extraordinary environments or conditions, as exemplified below. Accordingly, ROHM shall not be in any way responsible or liable for any damages, expenses or losses arising from the use of any ROHM's Products under any special or extraordinary environments or conditions. If you intend to use our Products under any special or extraordinary environments or conditions (as exemplified below), your independent verification and confirmation of product performance, reliability, etc. prior to use, must be necessary:
  - Use of our Products in any types of liquid, including water, oils, chemicals, and organic solvents
  - Use of our Products outdoors or in places where the Products are exposed to direct sunlight or dust
  - Use of our Products in places where the Products are exposed to sea wind or corrosive gases, including Cl<sub>2</sub>, H<sub>2</sub>S, NH<sub>3</sub>, SO<sub>2</sub>, and NO<sub>2</sub>
  - Use of our Products in places where the Products are exposed to static electricity or electromagnetic waves
  - Use of our Products in proximity to heat-producing components, plastic cords, or other flammable items
  - Sealing or coating our Products with resin or other coating materials
  - Use of our Products without cleaning residue of flux (even if you use no-clean type fluxes, cleaning residue of flux is recommended); or Washing our Products by using water or water-soluble cleaning agents for cleaning residue after soldering
  - Use of the Products in places subject to dew condensation
- The Products are not subject to radiation-proof design.
- Please verify and confirm characteristics of the final or mounted products in using the Products.
- In particular, if a transient load (a large amount of load applied in a short period of time, such as pulse. is applied, confirmation of performance characteristics after on-board mounting is strongly recommended. Avoid applying power exceeding normal rated power; exceeding the power rating under steady-state loading condition may negatively affect product performance and reliability.
- De-rate Power Dissipation (Pd) depending on Ambient temperature (Ta). When used in sealed area, confirm the actual ambient temperature.
- Confirm that operation temperature is within the specified range described in the product specification.
- ROHM shall not be in any way responsible or liable for failure induced under deviant condition from what is defined in this document.

## Precaution for Mounting / Circuit board design

- When a highly active halogenous (chlorine, bromine, etc.) flux is used, the residue of flux may negatively affect product performance and reliability.
- In principle, the reflow soldering method must be used; if flow soldering method is preferred, please consult with the ROHM representative in advance.

For details, please refer to ROHM Mounting specification

### Precautions Regarding Application Examples and External Circuits

1. If change is made to the constant of an external circuit, please allow a sufficient margin considering variations of the characteristics of the Products and external components, including transient characteristics, as well as static characteristics.
2. You agree that application notes, reference designs, and associated data and information contained in this document are presented only as guidance for Products use. Therefore, in case you use such information, you are solely responsible for it and you must exercise your own independent verification and judgment in the use of such information contained in this document. ROHM shall not be in any way responsible or liable for any damages, expenses or losses incurred by you or third parties arising from the use of such information.

### Precaution for Electrostatic

This Product is electrostatic sensitive product, which may be damaged due to electrostatic discharge. Please take proper caution in your manufacturing process and storage so that voltage exceeding the Products maximum rating will not be applied to Products. Please take special care under dry condition (e.g. Grounding of human body / equipment / solder iron, isolation from charged objects, setting of Ionizer, friction prevention and temperature / humidity control).

### Precaution for Storage / Transportation

1. Product performance and soldered connections may deteriorate if the Products are stored in the places where:
  - [a] the Products are exposed to sea winds or corrosive gases, including Cl<sub>2</sub>, H<sub>2</sub>S, NH<sub>3</sub>, SO<sub>2</sub>, and NO<sub>2</sub>
  - [b] the temperature or humidity exceeds those recommended by ROHM
  - [c] the Products are exposed to direct sunshine or condensation
  - [d] the Products are exposed to high Electrostatic
2. Even under ROHM recommended storage condition, solderability of products out of recommended storage time period may be degraded. It is strongly recommended to confirm solderability before using Products of which storage time is exceeding the recommended storage time period.
3. Store / transport cartons in the correct direction, which is indicated on a carton with a symbol. Otherwise bent leads may occur due to excessive stress applied when dropping of a carton.
4. Use Products within the specified time after opening a humidity barrier bag. Baking is required before using Products of which storage time is exceeding the recommended storage time period.

### Precaution for Product Label

QR code printed on ROHM Products label is for ROHM's internal use only.

### Precaution for Disposition

When disposing Products please dispose them properly using an authorized industry waste company.

### Precaution for Foreign Exchange and Foreign Trade act

Since our Products might fall under controlled goods prescribed by the applicable foreign exchange and foreign trade act, please consult with ROHM representative in case of export.

### Precaution Regarding Intellectual Property Rights

1. All information and data including but not limited to application example contained in this document is for reference only. ROHM does not warrant that foregoing information or data will not infringe any intellectual property rights or any other rights of any third party regarding such information or data. ROHM shall not be in any way responsible or liable for infringement of any intellectual property rights or other damages arising from use of such information or data.:
2. No license, expressly or implied, is granted hereby under any intellectual property rights or other rights of ROHM or any third parties with respect to the information contained in this document.

### Other Precaution

1. This document may not be reprinted or reproduced, in whole or in part, without prior written consent of ROHM.
2. The Products may not be disassembled, converted, modified, reproduced or otherwise changed without prior written consent of ROHM.
3. In no event shall you use in any way whatsoever the Products and the related technical information contained in the Products or this document for any military purposes, including but not limited to, the development of mass-destruction weapons.
4. The proper names of companies or products described in this document are trademarks or registered trademarks of ROHM, its affiliated companies or third parties.

**General Precaution**

1. Before you use our Products, you are requested to carefully read this document and fully understand its contents. ROHM shall not be in any way responsible or liable for failure, malfunction or accident arising from the use of any ROHM's Products against warning, caution or note contained in this document.
2. All information contained in this document is current as of the issuing date and subject to change without any prior notice. Before purchasing or using ROHM's Products, please confirm the latest information with a ROHM sales representative.
3. The information contained in this document is provided on an "as is" basis and ROHM does not warrant that all information contained in this document is accurate and/or error-free. ROHM shall not be in any way responsible or liable for any damages, expenses or losses incurred by you or third parties resulting from inaccuracy or errors of or concerning such information.

## Данный компонент на территории Российской Федерации

### Вы можете приобрести в компании MosChip.

Для оперативного оформления запроса Вам необходимо перейти по данной ссылке:

<http://moschip.ru/get-element>

Вы можете разместить у нас заказ для любого Вашего проекта, будь то серийное производство или разработка единичного прибора.

В нашем ассортименте представлены ведущие мировые производители активных и пассивных электронных компонентов.

Нашей специализацией является поставка электронной компонентной базы двойного назначения, продукции таких производителей как XILINX, Intel (ex.ALTERA), Vicor, Microchip, Texas Instruments, Analog Devices, Mini-Circuits, Amphenol, Glenair.

Сотрудничество с глобальными дистрибьюторами электронных компонентов, предоставляет возможность заказывать и получать с международных складов практически любой перечень компонентов в оптимальные для Вас сроки.

На всех этапах разработки и производства наши партнеры могут получить квалифицированную поддержку опытных инженеров.

Система менеджмента качества компании отвечает требованиям в соответствии с ГОСТ Р ИСО 9001, ГОСТ РВ 0015-002 и ЭС РД 009

### Офис по работе с юридическими лицами:

105318, г.Москва, ул.Щербаковская д.3, офис 1107, 1118, ДЦ «Щербаковский»

Телефон: +7 495 668-12-70 (многоканальный)

Факс: +7 495 668-12-70 (доб.304)

E-mail: [info@moschip.ru](mailto:info@moschip.ru)

Skype отдела продаж:

moschip.ru

moschip.ru\_4

moschip.ru\_6

moschip.ru\_9