



ETA-USA

HIGH QUALITY SWITCHING POWER SUPPLIES

AC/DC SWITCHING POWER SUPPLY
AC INPUT 85~264
SINGLE CHANNEL OUTPUT
150 WATTS

RoHS

BFE-SX-U1 SERIES

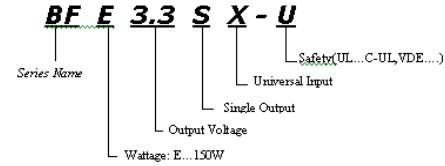

Dimension: 75W x 180L x 38H

General Description

"BF"-Series AC/DC Switching power supplies are board type power supplies matched with new designs, which is in accordance with harmonic current regulation, of ultra-small sizes, high efficiency and low cost. By adopting the synchronization regular method (output less than 6 V) for the first time for this class of devices, BF-Series is 40mm smaller in depth compared with equivalent products by other makers. At the same time low cost is realized to meet market needs.

Features

1. Board Type
2. Ultra Small size
3. Universal input(AC 85V to 264V)
4. Harmonic current complies to IEC61000-3-2
5. Power factor BFE: 0.98/0.93 (AC 100/230V)
6. High efficiency
7. Low Cost
8. EMI: complies to FCC class B, or EN55022 class B, or VCCI class B
9. Safety: UL 60950, C-UL, EN 60950-1

Options

N/A

Application

Industrial

Input

Input Voltage:	AC100-240V
Input Voltage Range:	AC85-264V
Input Current:	2.0-0.9 A
Frequency:	50/60Hz
Input Frequency Range:	47-63Hz
Phase:	Single
Inrush Current: *1	18A (typ.) at AC100V 41A (typ.) at AC230V
Leakage Current:	1mA (maximum) at 25°C (rated input/output and rated input frequency)

Output Characteristic	Unit	Models								
		BFE3.3SX	BFE05SX	BFE06SX	BFE09SX	BFE12SX	BFE15SX	BFE24SX	BFE36SX	BFE48SX
Output Voltage	Vdc	3.3	5	6	9	12	15	24	36	48
Output Current	A	30	30	25	17	13	10.5	6.7	4.5	3.4
Voltage Adjust Range	V	±10% of Rated Output Voltage								
Ripple&Noise(max)*2	mVpp	120/160		150 at 0 to 40°C /180 at -10 to 0°C						
Rise up time	mS	500mS(maximum) at 25°C and rated input/output								
Hold up time	mS	20mS(minimum) at 25°C and rated input/output								
Regulation										
a. Line Regulation	mV	9.9	15	18	27	36	45	72	108	144
b. Load Regulation *3	mV	40	40	50	40	40	40	100	150	150
c. Temperature Coefficient *4	°C	0.03 %/°C								
d. Drift(maximum) *5	mV	13.2	20	24	36	48	60	96	144	192
e. Dynamic Load Regulation (typ.) *6	mV	0.2	0.2	0.2	0.2	0.2	0.2	0.3	0.3	0.5
f. Recovery Time *6	mS	5 mS(typ.)								

Efficiency	%	76/79	80/82	80/83	82/85	83/86	83/86	84/87	85/88	85/88
Power Factor		0.97/0.92	0.98(typical) at AC100V/0.92(typical) at AC230V							



ETA USA
16170 Vineyard Blvd. Suite 180, Morgan Hill, CA 95037
Phone: 1-800-ETA-POWR, (408) 778-2793 Fax: (408) 779-2753

Visit us at: www.eta-usa.com
email at: sales@eta-usa.com



ETA-USA

HIGH QUALITY SWITCHING POWER SUPPLIES

Environmental Specification			
Operating Temperature	-10 to +50 °C		
Operating Humidity	less than 85%/RH(non-condensing)		
Storage Temperature	-20 to +85 °C		
Storage Humidity	less than 85%/RH(non-condensing)		
Withstanding Voltage	Primary-Secondary	AC3,000V for 1minute	
	Primary-Frame Ground	AC2,500V for 1minute	
	Secondary-Frame Ground	AC500V for 1minute	
Isolation Resistance	Primary-Secondary-Frame Ground	50MΩ(minimum) by DC500V insulation tester	
Vibration	5-10Hz:10mm double amplitude,10-55Hz:19.6m/s ² ,20minutes' period for 60minutes each along X,Y,Z axes(non-operating)		
Shock	294m/s ²		
Cooling	Convection		
Environmental Agencies			
Line Conducted Noise	Built to meet FCC Part15-B Class B Built to meet VCCI Class B Built to meet CISPR Class B Built to meet EN55022 Class B		
Line Harmonic Distortion	Built to meet IEC61000-3-2		
Safety	UL: UL60950-1 2 nd edition, IEC61000-3-2 C-UL: CSA60950 VDE EN60950-1 2006, IEC950,		
MTBF [H]	347000	377000	398000
Switching Frequency[kHz]	100 (typ.)		
Function/Protection			
Over current Protection	Current Limiting with automatic recovery		
Over voltage Protection	output shutdown(to reset,leave 1minute after shut-off)		
Remote Sense	not available		
Remote On/Off	not available		
Power Fail Detection	not available		
Series Operation	available		
Parallel Operation	not available		
Mechanical			
Dimension [mm]	75W × 180L × 38H		
Weight [g] (typical)	420g		

Conditions:

- *1 cold start
- *2 measured by a bayonet probe at the end of a pair of 5cm long wires terminated with a 100uF electrolytic capacitor and 0.1uF film capacitor in parallel at a 0 to 100MHz bandwidth
- *3 when output current changed from 0mA to rated output current
- *4 at -10 to +40°C
- *5 for 7hour period after 1hour warm-up at 25°C and rated input/output
- *6 when output current changed from 25% to 75% of rated output current rapidly at rated input



ETA USA

16170 Vineyard Blvd. Suite 180, Morgan Hill, CA 95037
Phone: 1-800-ETA-POWR, (408) 778-2793 Fax: (408) 779-2753

Visit us at: www.eta-usa.com
email at: sales@eta-usa.com



ETA-USA

HIGH QUALITY SWITCHING POWER SUPPLIES

DIMENSION DIAGRAM (mm)

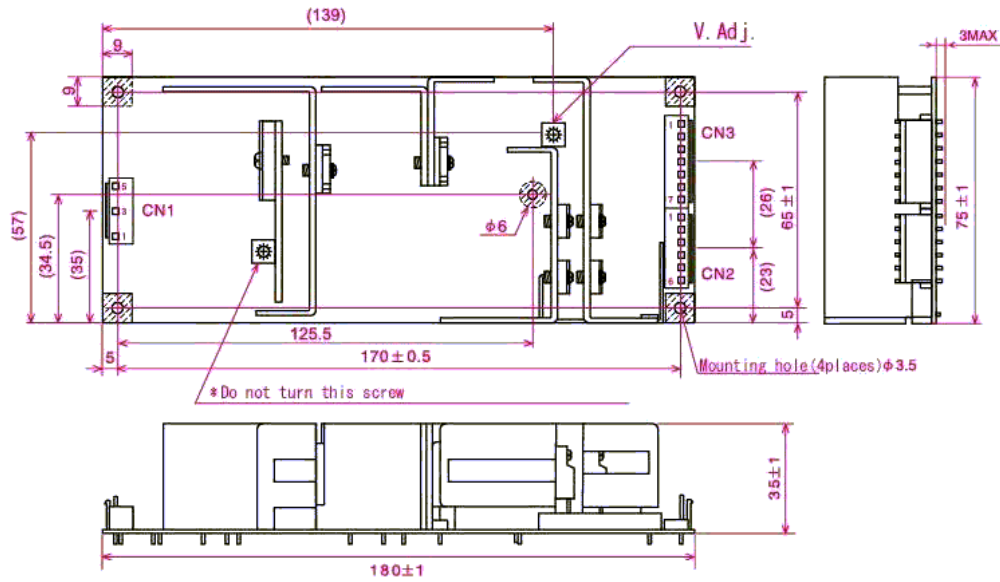

The cover touches the shaded area

CN1	
Pin no.	Function
1	AC IN(L)
3	AC IN(N)
5	FG

CN2	
Pin no.	Function
1	+V OUT
2	+V OUT
3	+V OUT
4	+V OUT
5	+V OUT
6	+V OUT

CN3	
Pin no.	Function
1	0V OUT
2	0V OUT
3	0V OUT
4	0V OUT
5	0V OUT
6	0V OUT
7	0V OUT

Mating housing	Contact
CN1 VHR5N	SVH-21T-P1.1
CN2 VHR6N	SVH-21T-P1.1
CN3 VHR7N	SVH-21T-P1.1

Maker: J. S. T

BLOCK DIAGRAM

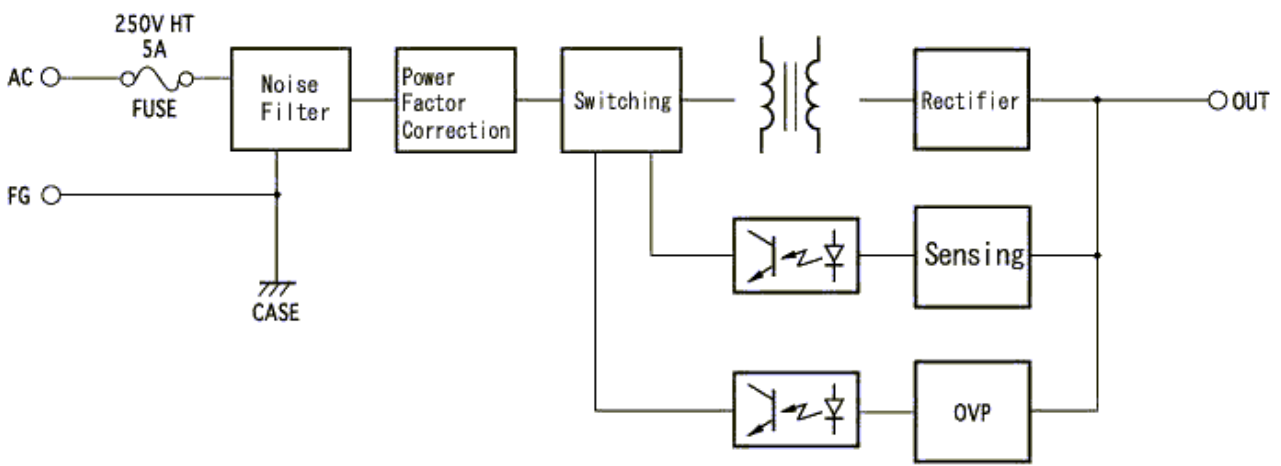



ETA-USA

HIGH QUALITY SWITCHING POWER SUPPLIES

DERATING CURVE

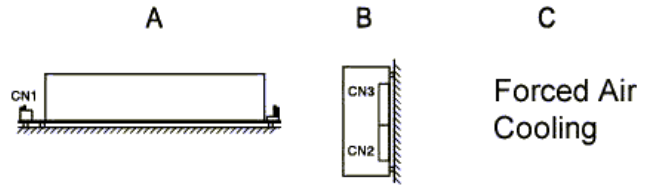
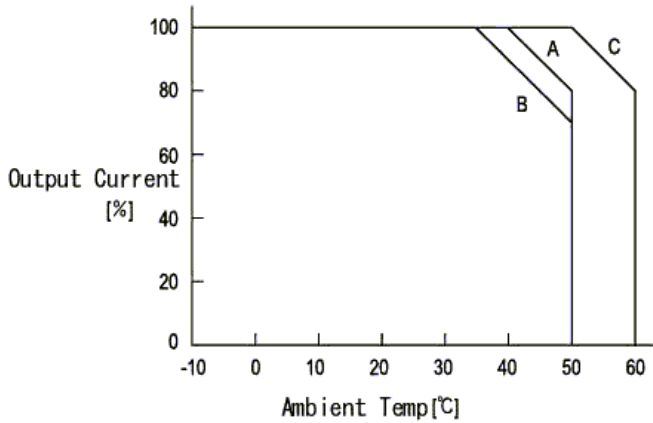

※ For safety specification, contact ETA Sales Representative

EFFICIENCY CURVE

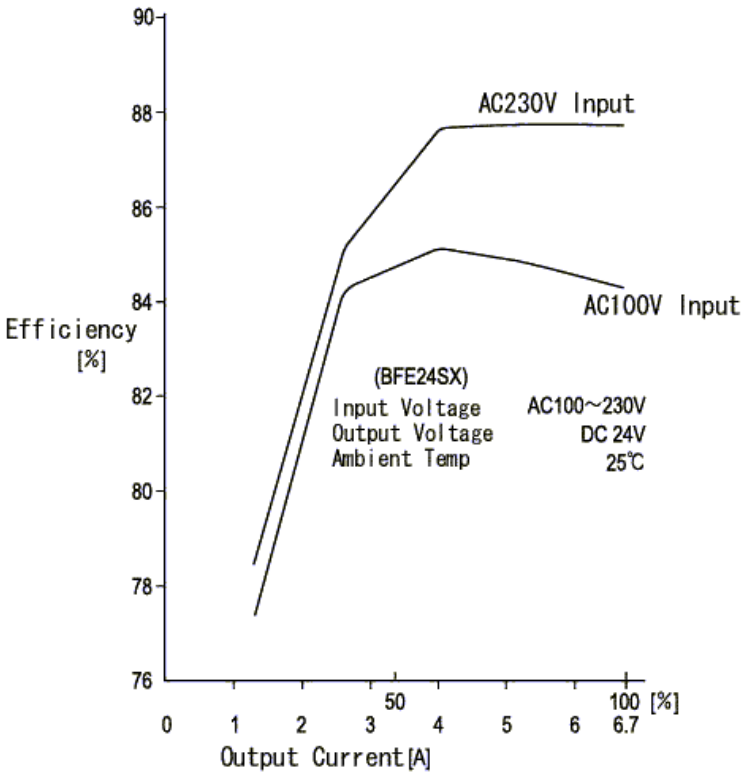

OCP CURVE

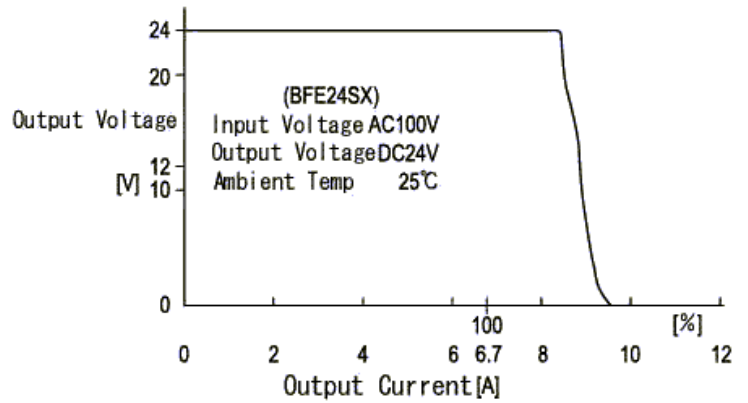

ETA USA
16170 Vineyard Blvd. Suite 180, Morgan Hill, CA 95037
Phone: 1-800-ETA-POWR, (408) 778-2793 Fax: (408) 779-2753

Visit us at: www.eta-usa.com
email at: sales@eta-usa.com

Данный компонент на территории Российской Федерации

Вы можете приобрести в компании MosChip.

Для оперативного оформления запроса Вам необходимо перейти по данной ссылке:

<http://moschip.ru/get-element>

Вы можете разместить у нас заказ для любого Вашего проекта, будь то серийное производство или разработка единичного прибора.

В нашем ассортименте представлены ведущие мировые производители активных и пассивных электронных компонентов.

Нашей специализацией является поставка электронной компонентной базы двойного назначения, продукции таких производителей как XILINX, Intel (ex.ALTERA), Vicor, Microchip, Texas Instruments, Analog Devices, Mini-Circuits, Amphenol, Glenair.

Сотрудничество с глобальными дистрибьюторами электронных компонентов, предоставляет возможность заказывать и получать с международных складов практически любой перечень компонентов в оптимальные для Вас сроки.

На всех этапах разработки и производства наши партнеры могут получить квалифицированную поддержку опытных инженеров.

Система менеджмента качества компании отвечает требованиям в соответствии с ГОСТ Р ИСО 9001, ГОСТ РВ 0015-002 и ЭС РД 009

Офис по работе с юридическими лицами:

105318, г.Москва, ул.Щербаковская д.3, офис 1107, 1118, ДЦ «Щербаковский»

Телефон: +7 495 668-12-70 (многоканальный)

Факс: +7 495 668-12-70 (доб.304)

E-mail: info@moschip.ru

Skype отдела продаж:

moschip.ru

moschip.ru_4

moschip.ru_6

moschip.ru_9