



LIGHTING FOREVER

6 PIN DIP PHOTO COUPLER Schmitt Trigger

H11Lx Series

Features:

- High data rate, 1MHz typical (NRZ)
- Free from latch up and oscillation throughout voltage and temperature ranges.
- Microprocessor compatible drive
- Logic compatible output sinks 16mA at 0.4V maximum
- Guaranteed on/off threshold hysteresis
- Wide supply voltage capability, compatible with all popular logic systems
- High isolation voltage between input and output (Viso=5000 V rms)
- Compact dual-in-line package
- Pb free and RoHS compliant.
- UL approved (No. E214129)
- VDE approval (No.132249)
- SEMKO approved
- NEMKO approved
- DEMKO approved
- FIMKO approved
- CSA approved (No. 2007798)



Description

The H11LX series of devices each consist of a GaAs infrared emitting diode optically coupled a high speed integrated circuit detector. The output detector incorporates a Schmitt trigger, which provides hysteresis for noise immunity and pulse shaping.

The devices are in a 6-pin DIP package and available in wide-lead spacing and SMD option.

Applications

- Logic to logic isolator
- Programmable current level sensor
- Line receiver — eliminate noise and transient problems
- AC to TTL conversion — square wave shaping
- Digital programming of power supplies
- Interfaces computers with peripherals

Schematic

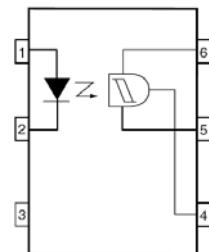

1. Anode
2. Cathode
3. No Connection
4. V_O
5. GND
6. V_{CC}

Truth Table

Input	Output
H	L
L	H



LIGHTING FOREVER

6 PIN DIP PHOTO COUPLER Schmitt Trigger

H11Lx Series

Absolute Maximum Ratings ($T_a=25^{\circ}\text{C}$)

Parameter		Symbol	Rating	Unit
Input	Forward current	I_F	60	mA
	Reverse voltage	V_R	6	V
	Power dissipation	P_D	120	mW
Output	V_{45} Allowed Range	V_o	0 to 16	V
	V_{65} Allowed Range	V_{CC}	3 to 16	V
	Output Current	I_o	50	mA
	power dissipation	P_D	150	mW
Total power dissipation		P_{tot}	250	mW
Isolation voltage ^{*1}		V_{iso}	5000	V rms
Operating temperature		T_{opr}	-55~+100	°C
Storage temperature		T_{stg}	-55~+150	°C
Soldering temperature ^{*2}		T_{sol}	260	°C

Notes

*1 AC for 1 minute, R.H.= 40 ~ 60% R.H. In this test, pins 1, 2 & 3 are shorted together, and pins 4, 5 & 6 are shorted together.

*2 For 10 seconds.



LIGHTING FOREVER

6 PIN DIP PHOTO COUPLER

Schmitt Trigger

H11Lx Series

Electrical Characteristics (T_a=25°C unless specified otherwise)

Input

Parameter	Symbol	Min.	Typ.*	Max.	Unit	Condition
Forward voltage	V _F	-	1.15	1.5	V	I _F = 10mA
Reverse Leakage current	I _R	-	-	10	μA	V _R = 5V
Capacitance	C _J	-	-	100	pF	V=0, f=1MHz

Output

Parameter	Symbol	Min.	Typ.*	Max.	Unit	Condition
Operation Voltage Range	V _{CC}	3	-	15	V	
Supply Current	I _{CC(off)}	-	1.6	5	mA	I _F =0mA, V _{CC} =5V
Output Current, High	I _{OH}	-	-	100	μA	I _F =0mA, V _{CC} =V _O =15V
Isolation Resistance	R _{ISO}	10 ¹¹	-	-	Ω	V _{I-O} =500VDC

Transfer Characteristics

Parameter	Symbol	Min.	Typ.*	Max.	Unit	Condition
Supply Current	I _{CC(on)}	-	1.6	5	mA	I _F =10mA, V _{CC} =5V
Output Voltage .low	V _{OL}	-	-	0.4	V	V _{CC} =5V, I _F =I _{Fon} (max.), R _L =270Ω
Turn on Threshold Current ¹	H11L1	-	-	1.6	mA	V _{CC} =5V, R _L =270Ω
	H11L2	-	-	10		
	H11L3	-	-	5		
Turn off Threshold Current	I _{Foff}	-	1	-	mA	V _{CC} =5V, R _L =270Ω
Hysteresis Ratio	I _{Fon} /I _{Foff}	0.5	-	0.9		V _{CC} =5V, R _L =270Ω
Turn on Time	t _{on}	-	-	4	μS	V _{CC} =5V, I _F =I _{Fon} , R _L =270Ω
Fall Time	t _r	-	0.1	-	μS	
Turn off Time	t _{off}	-	-	4	μS	
Rise Time	t _r	-	0.1	-	μS	
Data Rate		-	1	-	MHz	

* Typical values at T_a = 25°C

¹. Max. I_{F(ON)} is the maximum current required to trigger the output. For examples, a 1.6mA maximum trigger current would require the LED to be driven at a current greater than 1.6mA to guarantee the device will turn on. A 10% guard band is recommended to account for degradation of the LED over its lifetime. The maximum allowable LED drive current is 60mA.

Typical Performance Curves

Figure 1. Forward Current vs Forward Voltage

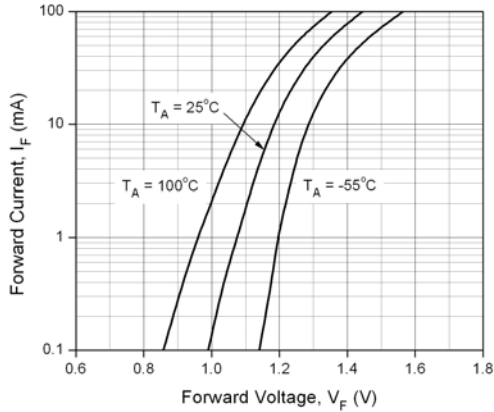

Figure 2. Transfer Characteristics

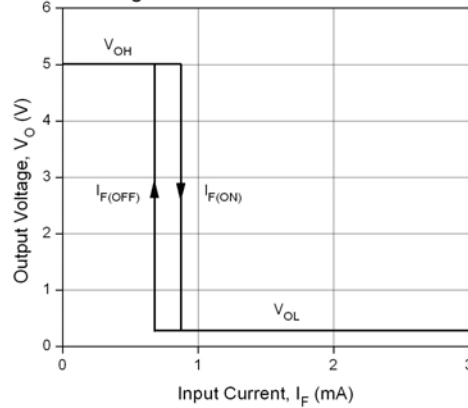

Figure 3. Turn On Threshold Current vs Supply Voltage

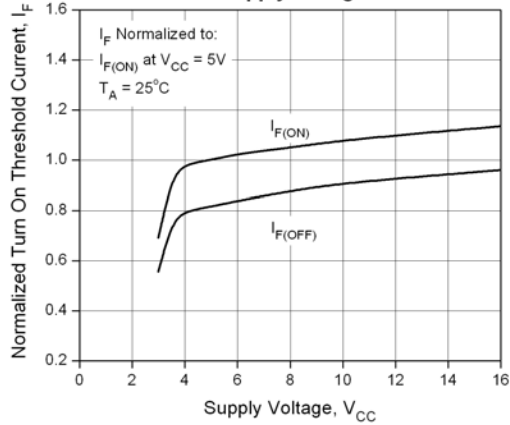

Figure 4. Turn On Threshold Current vs Ambient Temperature

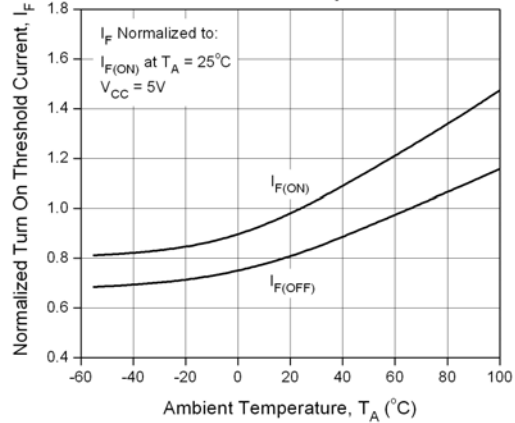

Figure 5. Low Level Output Voltage vs Load Current

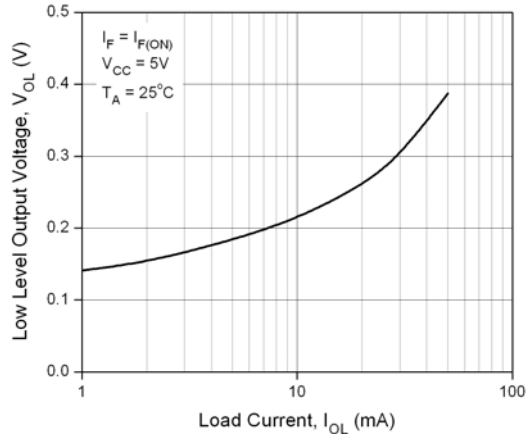
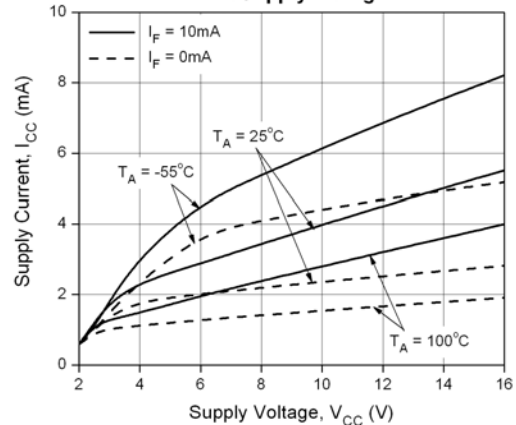

Figure 6. Supply Current vs Supply Voltage



6 PIN DIP PHOTO COUPLER Schmitt Trigger

H11Lx Series

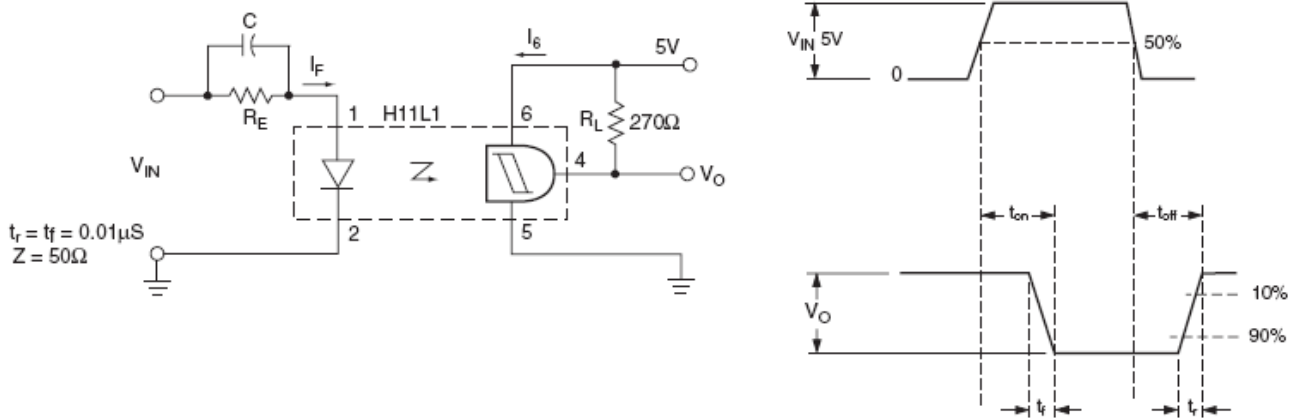

Figure. 7 Switching test circuit and waveform

Order Information

Part Number

H11LXY(Z)-V

Note

- X = Part No. for 1, 2 or 3
- Y = Lead form option (S, S1, M or none)
- Z = Tape and reel option (TA, TB or none).
- V = VDE (optional)

Option	Description	Packing quantity
None	Standard DIP-6	65 units per tube
M	Wide lead bend (0.4 inch spacing)	65 units per tube
S + TA	Surface mount lead form + TA tape & reel option	1000 units per reel
S + TB	Surface mount lead form + TB tape & reel option	1000 units per reel
S1 + TA	Surface mount lead form (low profile) + TA tape & reel option	1000 units per reel
S1 + TB	Surface mount lead form (low profile) + TB tape & reel option	1000 units per reel



LIGHTING FOREVER

6 PIN DIP PHOTO COUPLER Schmitt Trigger

H11Lx Series

Package Drawings

(Dimensions in mm)

Standard DIP Type

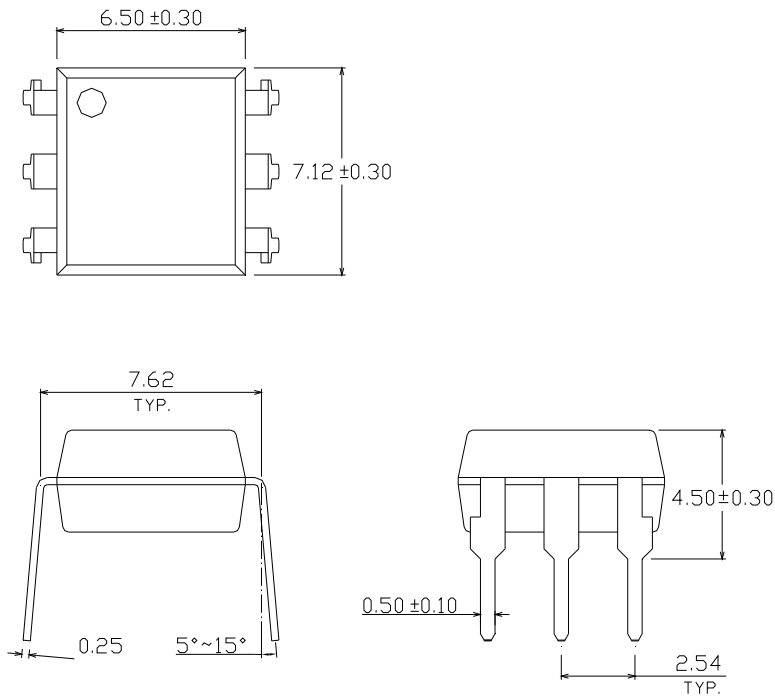

Option M Type

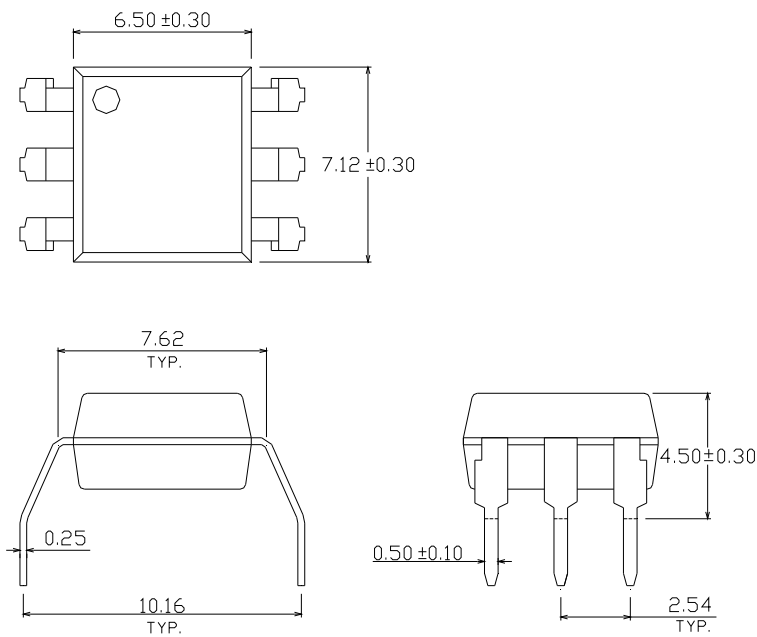



LIGHTING FOREVER

6 PIN DIP PHOTO COUPLER Schmitt Trigger

H11Lx Series

Option S Type

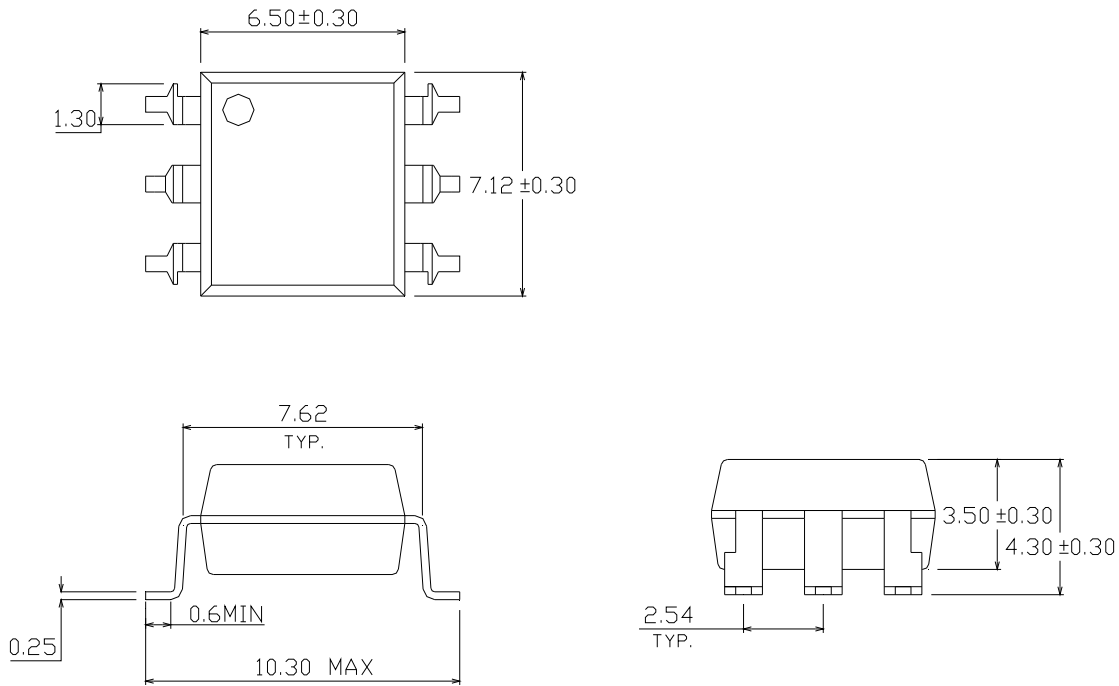

Option S1 Type

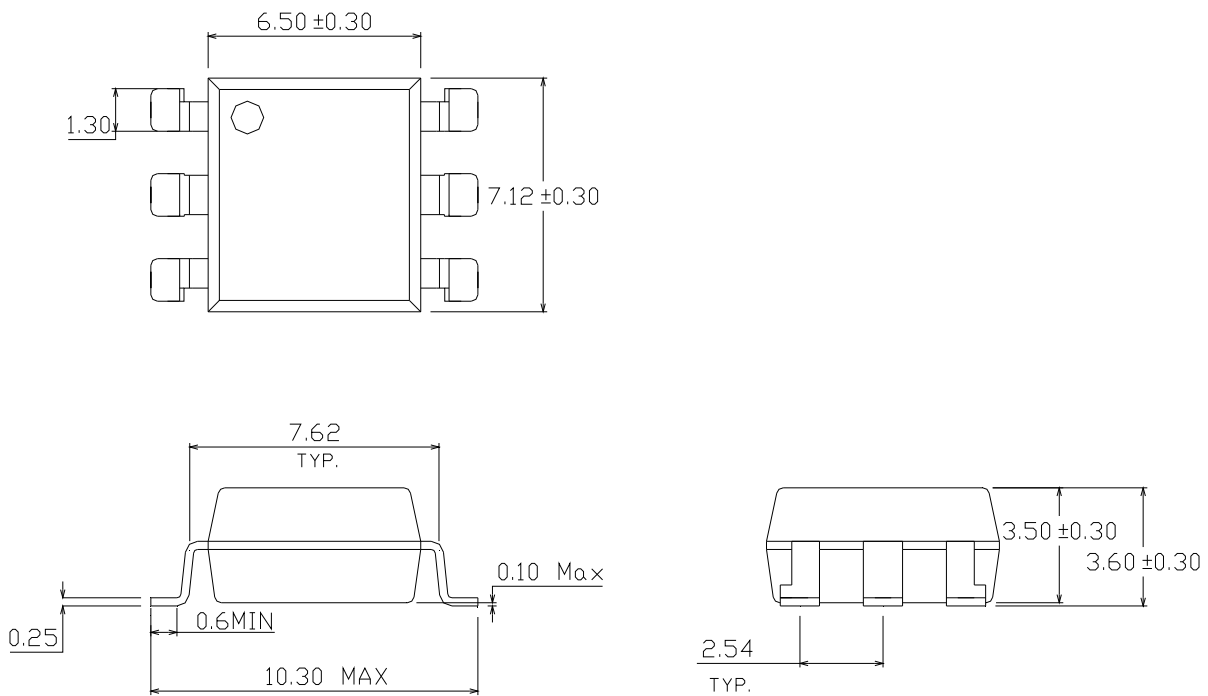



LIGHTING FOREVER

6 PIN DIP PHOTO COUPLER Schmitt Trigger

H11Lx Series

Recommended pad layout for surface mount leadform

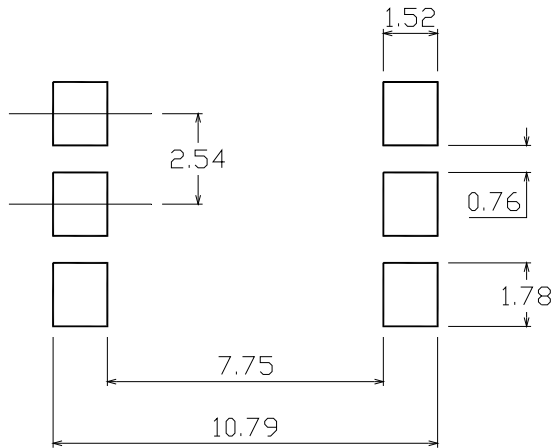

Device Marking

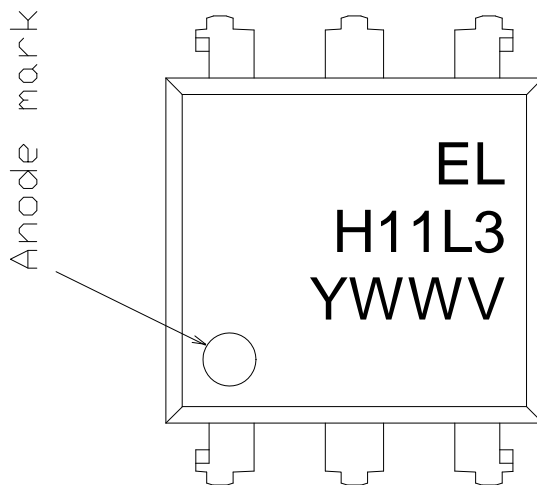

Notes

- EL denotes Everlight
- H11L3 denotes Device Number
- Y denotes 1 digit Year code
- WW denotes 2 digit Week code
- V denotes VDE (optional)



LIGHTING FOREVER

6 PIN DIP PHOTO COUPLER Schmitt Trigger

H11Lx Series

Tape & Reel Packing Specifications

Option TA

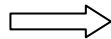
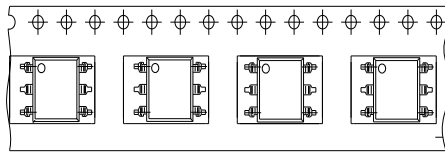

Direction of feed from reel

Option TB

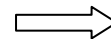
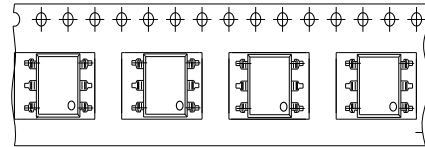

Direction of feed from reel

Tape dimensions

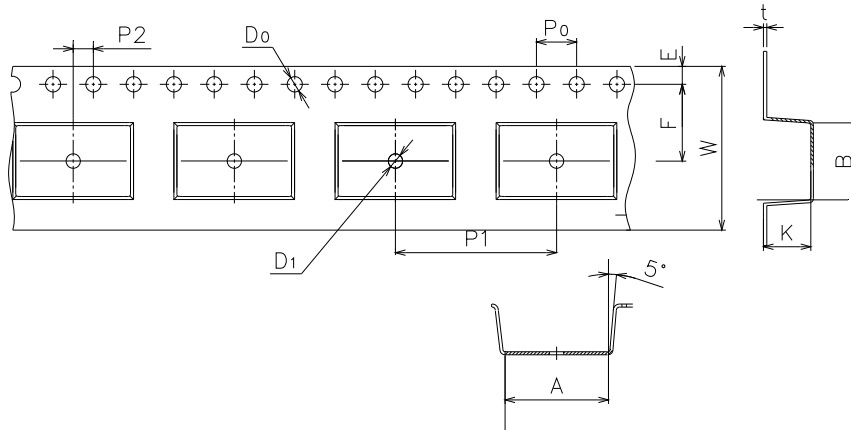

Dimension No.	A	B	Do	D1	E	F
Dimension (mm)	10.4±0.1	7.52±0.1	1.5±0.1	1.5+0.1/-0	1.75±0.1	7.5±0.1

Dimension No.	Po	P1	P2	t	W	K
Dimension (mm)	4.0±0.15	1.6±0.1	2.0±0.1	0.35±0.03	16.0±0.2	4.5±0.1



LIGHTING FOREVER

6 PIN DIP PHOTO COUPLER Schmitt Trigger

H11Lx Series

Solder Reflow Temperature Profile

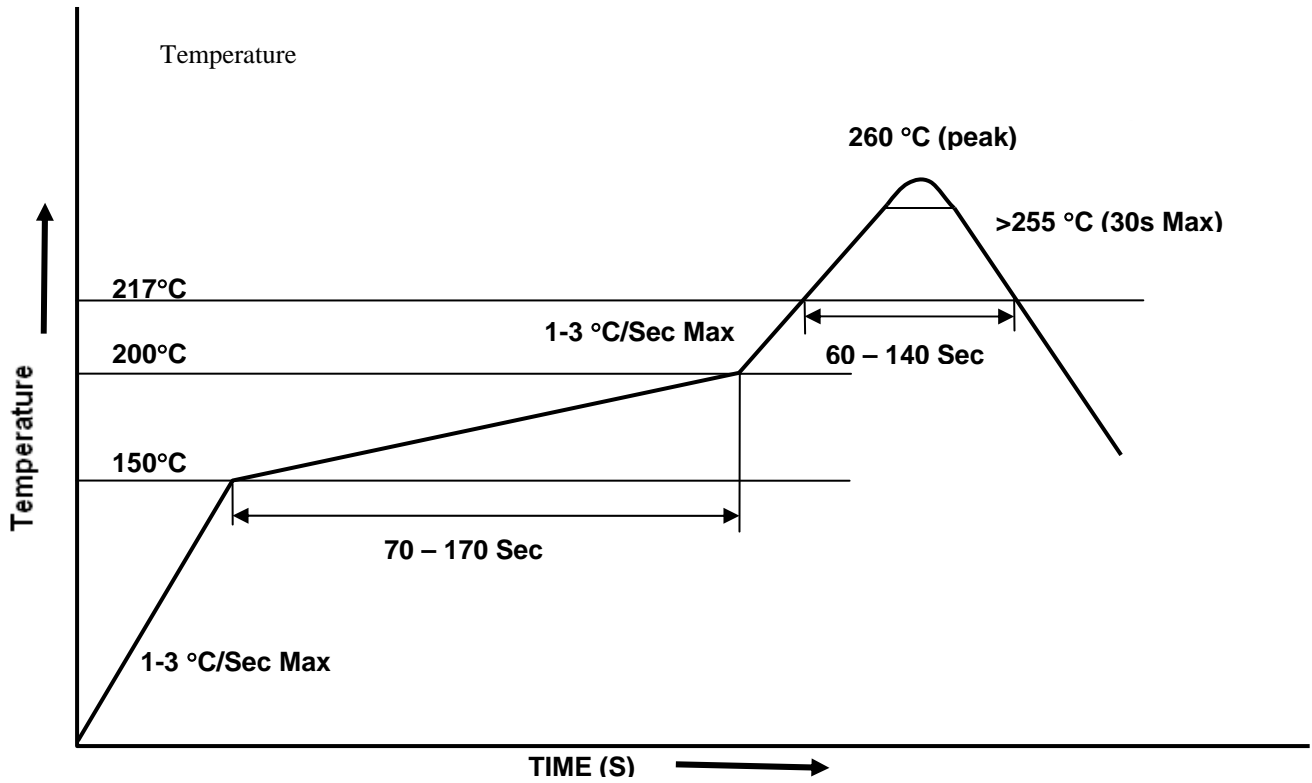



LIGHTING FOREVER

6 PIN DIP PHOTO COUPLER

Schmitt Trigger

H11Lx Series

DISCLAIMER

1. The specifications in this datasheet may be changed without notice. EVERLIGHT reserves the authority on material change for above specification.
2. When using this product, please observe the absolute maximum ratings and the instructions for use as outlined in this datasheet. EVERLIGHT assumes no responsibility for any damage resulting from use of the product which does not comply with the absolute maximum ratings and the instructions included in this datasheet.
3. These specification sheets include materials protected under copyright of EVERLIGHT. Reproduction in any form is prohibited without the specific consent of EVERLIGHT.

Данный компонент на территории Российской Федерации

Вы можете приобрести в компании MosChip.

Для оперативного оформления запроса Вам необходимо перейти по данной ссылке:

<http://moschip.ru/get-element>

Вы можете разместить у нас заказ для любого Вашего проекта, будь то серийное производство или разработка единичного прибора.

В нашем ассортименте представлены ведущие мировые производители активных и пассивных электронных компонентов.

Нашей специализацией является поставка электронной компонентной базы двойного назначения, продукции таких производителей как XILINX, Intel (ex.ALTERA), Vicor, Microchip, Texas Instruments, Analog Devices, Mini-Circuits, Amphenol, Glenair.

Сотрудничество с глобальными дистрибьюторами электронных компонентов, предоставляет возможность заказывать и получать с международных складов практически любой перечень компонентов в оптимальные для Вас сроки.

На всех этапах разработки и производства наши партнеры могут получить квалифицированную поддержку опытных инженеров.

Система менеджмента качества компании отвечает требованиям в соответствии с ГОСТ Р ИСО 9001, ГОСТ РВ 0015-002 и ЭС РД 009

Офис по работе с юридическими лицами:

105318, г.Москва, ул.Щербаковская д.3, офис 1107, 1118, ДЦ «Щербаковский»

Телефон: +7 495 668-12-70 (многоканальный)

Факс: +7 495 668-12-70 (доб.304)

E-mail: info@moschip.ru

Skype отдела продаж:

moschip.ru

moschip.ru_4

moschip.ru_6

moschip.ru_9