



THCV242

SerDes receiver with bi-directional transceiver

1. General Description

THCV242 is designed to support 1080p60 2Mpixel uncompressed video data over 15m 100ohm differential STP or single-end 50ohm Coaxial cable with 4 in-line connectors between camera and processor by V-by-One® HS.

THCV242 supports a MIPI CSI-2. Each CSI-2 data lane can transmit up to 1.2Gbps/lane. Virtual channel is supported. MIPI 2nd port output supports data copy and distribution.

One high-speed V-by-One® HS lane can transmit up to 1080p60fps. The maximum serial data rate is 4Gbps/lane. 2nd input lane supports HDR large amount of data or camera switch experience.

THCV242 is capable to control and monitor remote camera module from MPU via GPIO or 1Mbps 2-wire serial interface.

Several fault and error detection function including CRC provides hardware functional safety design.

2. Features

- MIPI CSI-2 with 1,2 or 4-lane output
- MIPI D-PHY supports 80Mbps~1.2Gbps
- MIPI Virtual channel supported
- Video formats: RAW8/10/12/14/16/20, YUV422/420, RGB888/666/565, JPEG, User-defined generic 8-bit
- V-by-One® HS 400Mbps~4Gbps x2lane
- V-by-One® HS standard version1.5
- Video stream switch and copy/distribution
- Frame sync remote supply scheme for multiple camera stream synchronization
- Wide range IO voltage from 1.7V to 3.6V
- 2-wire serial interface 1Mbps bridge function
- Remote GPIO/UART control and monitoring
- Error detection including CRC and notification
- QFN64 9x9mm 0.5mm pitch Exp-pad package

3. Block Diagram

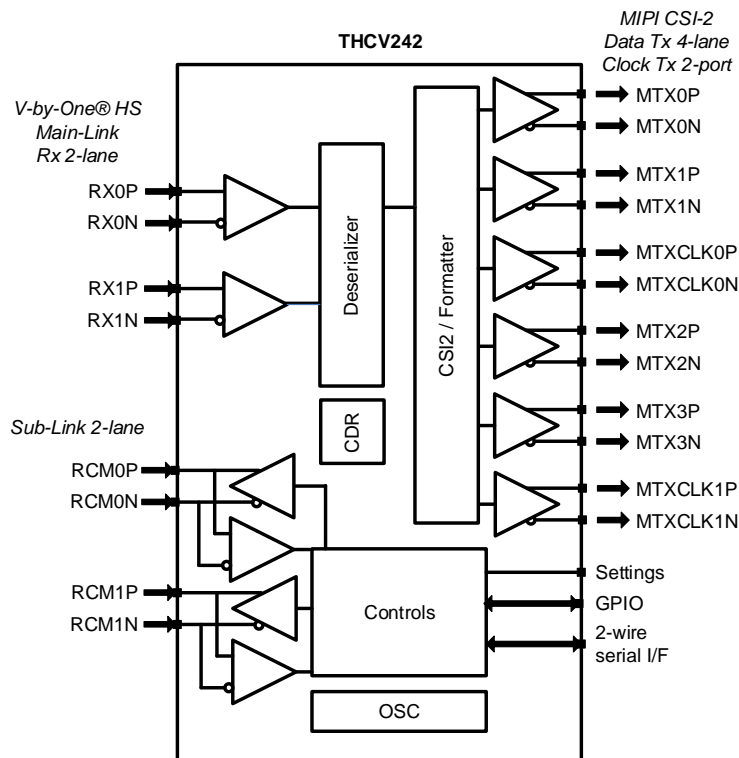

Contents page

1. General Description.....	1
2. Features	1
3. Block Diagram	1
4. Pin Configuration	4
5. Pin Description.....	5
6. Functional Description	6
6.1. Functional Overview	6
6.2. V-by-One® HS	6
6.2.1. V-by-One® HS input setting	6
6.2.2. MPRF (Main-Link PRivate Format)	7
6.2.3. V-by-One® HS standard format	8
6.2.4. Link Status (HTPDN/LOCKN).....	12
6.3. Local, Remote and Remote Slave Register Programming	14
6.3.1. 2-wire serial I/F slave Device ID.....	14
6.3.2. 2-wire serial Read/Write access to local Register.....	15
6.3.3. 2-wire serial I/F Watch Dog Timer	16
6.3.4. Sub-Link setting	17
6.3.5. Sub-Link 2-wire Read/Write access to remote Register.....	18
6.3.5.1. Sub-Link 2-wire Set and Trigger mode	18
6.3.5.2. Sub-Link 2-wire Pass Through mode	21
6.3.6. Sub-Link transaction time accuracy Improvement.....	24
6.4. GPIO setting	25
6.4.1. Register GPIO	26
6.4.2. Through GPIO.....	27
6.4.3. GPIO as secondary 2-wire port	28
6.5. MIPI	29
6.5.1. Deserializer and CSI-2 Formatter.....	29
6.5.1.1. PLL setting	29
6.5.1.2. Video stream switch and copy/distribution.....	31
6.5.2. Header/Packet/Sync Pre-processing	32
6.5.3. MIPI output setting.....	33
6.5.4. MIPI CSI-2 Virtual Channel.....	35
6.5.5. Multiple camera synchronization Frame Vsync supply	36
6.6. Status monitoring, Interrupt and Error Detection	38
6.6.1. Internal Error / status signal monitoring pin output.....	38



6.6.2.	Internal Error / status signal monitoring	41
6.6.3.	Interrupt monitoring	42
6.6.4.	Register Auto Checksum diagnosis	43
6.7.	Power On Sequence.....	44
6.8.	Lock / Re-Lock Sequence	45
7.	Absolute Maximum Ratings.....	46
8.	Recommended Operating Conditions.....	46
9.	Consumption Current	47
10.	DC Specifications.....	48
10.1.	CMOS DC Specifications.....	48
10.2.	CML Receiver DC Specifications	48
10.3.	MIPI Transmitter DC Specifications	49
10.4.	CML Bi-directional Buffer DC Specifications	50
11.	AC Specifications.....	51
11.1.	General AC Specifications	51
11.2.	CML Receiver AC Specifications	51
11.3.	MIPI Transmitter AC Specifications	51
11.4.	CML B-directional Buffer AC Specifications	51
11.5.	2-wire serial Slave AC Specifications	51
12.	Package.....	52
13.	Notices and Requests.....	53

MIPI is a licensed trademark of MIPI, Inc. in the U.S. and other jurisdictions.

4. Pin Configuration

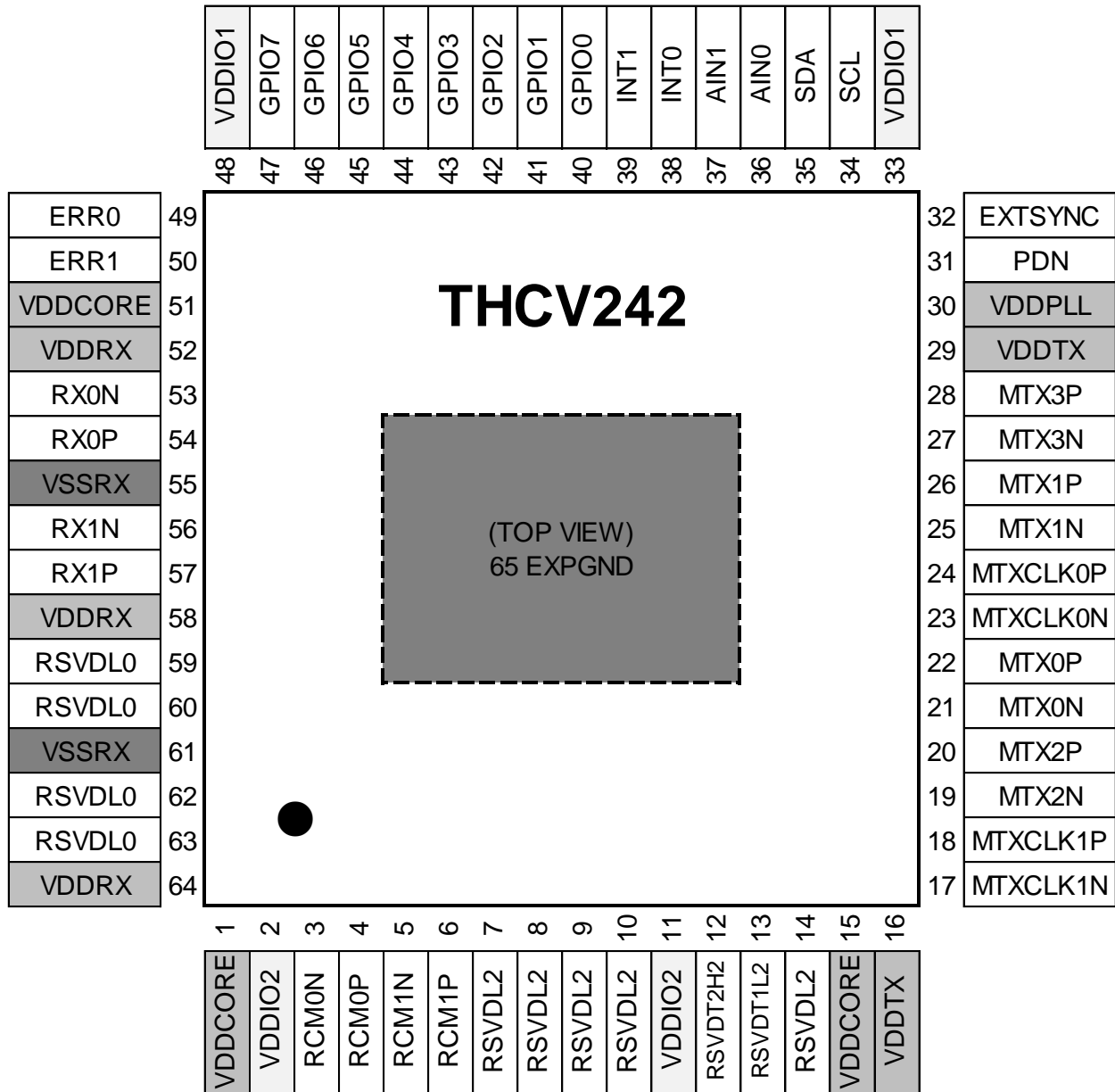

5. Pin Description

Pin Name	Pin #	type*	Description
RX0P/N	54, 53	CI	V-by-One® HS Input lane0
RX1P/N	57, 56	CI	V-by-One® HS Input lane1
RCM0P/N	4, 3	CB	CML Bi-directional Input/Output (Sub-Link).
RCM1P/N	6, 5	CB	CML Bi-directional Input/Output (Sub-Link).
MTX0P/N	22, 21	MO	MIPI differential data outputs lane0
MTX1P/N	26, 25	MO	MIPI differential data outputs lane1
MTX2P/N	20, 19	MO	MIPI differential data outputs lane2
MTX3P/N	28, 27	MO	MIPI differential data outputs lane3
MTXCLK0P/N	24, 23	MO	MIPI differential clock outputs lane0
MTXCLK1P/N	18, 17	MO	MIPI differential clock outputs lane1
RSVDT1L2	13	I2	Reserved Pin, Must be tied to ground for normal operation.
RSVDT2H2	12	I2	Reserved pin. Must be tied to VDDIO2 for normal operation.
PDN	31	I1	Power Down (User Power On Reset control must be required.) 0: Power Down Mode 1: Normal Operation
AIN1	37	I1	Device Address Setting for 2-wire Serial Interface [AIN1:AIN0]=00: ID=7'h0B [AIN1:AIN0]=01: ID=7'h34
AIN0	36	I1	[AIN1:AIN0]=10: ID=7'h77 [AIN1:AIN0]=11: ID=7'h65
SCL	34	B	2-wire Serial Interface clock line
SDA	35	B	2-wire Serial Interface data line
GPIO0	40	B	General Purpose Input/Output
GPIO1	41	B	General Purpose Input/Output
GPIO2	42	B	General Purpose Input/Output
GPIO3	43	B	General Purpose Input/Output
GPIO4	44	B	General Purpose Input/Output
GPIO5	45	B	General Purpose Input/Output
GPIO6	46	B	General Purpose Input/Output
GPIO7	47	B	General Purpose Input/Output
INT0	38	O	Interrupt signal output. It must be connected with a pull-up resistor.
INT1	39	O	0: Interrupt occurred 1: Steady state
ERR0	49	O	Internal Error / status signal monitoring output
ERR1	50	O	Internal Error / status signal monitoring output
EXTSYNC	32	B	External Sync input/output for multiple camera synchronization
RSVDL0	59, 60, 62, 63	I0	Reserved Pins, Must be tied to ground for normal operation.
RSVDL2	7, 8, 9, 10, 14	I2	Reserved Pins, Must be tied to ground for normal operation.
VDDIO1	33, 48	P	Power Supply for CMOS I/O
VDDIO2	2,11	P	Power Supply for Sub-Link I/O
VDDCORE	1,15,51	P	Power Supply for Digital Circuit
VDDRFX	52,58,64	P	Power Supply for Analog Circuit
VSSRX	55,61	G	GND for Analog Circuit
VDDTX	16,29	P	Power Supply for Analog Circuit
VDDPLL	30	P	Power Supply for Analog Circuit
EXPAND	65	G	Exposed GND Pad

*type symbol ; MO=MIPI Output, CI=CML Input, CB=CML Bi-directional input/output

I0=1.2V CMOS Input, I1=1.8~3.3V VDDIO1 domain CMOS Input, I2=1.8~3.3V VDDIO2 domain CMOS Input

O=1.8~3.3V VDDIO1 domain CMOS Output, B=1.8~3.3V VDDIO1 domain CMOS Bi-directional input/output

P=Power, G=Ground

6. Functional Description

6.1. Functional Overview

THCV242 can receive CML video signal transmitted over 15m length and encode it to MIPI CSI-2 format. With High Speed CML SerDes, high reliability and robustness encoding scheme and CDR (Clock and Data Recovery) architecture, the THCV242 enables to receive RAW/YUV/RGB/JPEG/Generic8bit data through Main-Link by single 100ohm differential pair or 50ohm Coax cable with minimal external components. In addition, THCV242 has Sub-Link which enables bi-directional transmission of 2-wire serial interface signals, GPIO signals and also HTPDN/LOCKN signals for Main-Link through the other 1-pair of CML-Line. The THCV242 system is able to watch remote devices and to control them via 2-wire serial interface or GPIOs. They also can report interrupt events caused by change of remote device statuses and internal statuses such as CRC error.

6.2. V-by-One® HS

6.2.1. V-by-One® HS input setting

Setting of V-by-One® HS input format can be configurable by 2-wire access to internal register.

Table 1. V-by-One® HS input format setting

Adr	bit	Register Name	width	R/W	init	Description
0x10 10	[7:6]	R_MLNK_NHSEL0	2	R/W	2'h2	V-by-One® Main-Link Mode Select (for LINK0) 00 : Reserved 01 : Reserved 10 : V-by-One® HS standard mode 11 : Reserved
0x10 10	[5:4]	R_MLNK_COLO	2	R/W	2'h1	V-by-One® Main-Link Byte Mode Select (for LINK0) 00 : Reserved 01 : 8bit (3Byte mode) 10 : 10bit (4Byte mode) 11 : Reserved
0x10 12	[4]	R_RGB565_ON_L0	1	R/W	1'b0	Main-Link Input Data Format Setting2 (This register could use only when R_VX1_LANE_FMT0=0x1) 0: RGB888 1: RGB565
0x10 12	[3:0]	R_VX1_LANE_FMT0	4	R/W	4'h0	Main-Link Input Data Format Setting 0: MPRF 1: RGBxxx 2,3,4,5,6: YUV422 (NormalYU1,NormalYU2,NormalYU3, DemuxYU1, DemuxYU2) 7,8,9: RAW8 (NormalR081,NormalR082, DemuxR081) 10,11,12: RAW10 (NormalR101, DemuxR101, DemuxR102) 13,14,15: RAW12 (NormalR121, DemuxR121, DemuxR122)
0x10 14	[7:6]	R_VRZ_NHSEL1	2	R/W	2'h2	V-by-One® Main-Link Mode Select (for LINK1) 00 : Reserved 01 : Reserved 10 : V-by-One® HS standard mode 11 : Reserved
0x10 14	[5:4]	R_VRZ_COL1	2	R/W	2'h1	V-by-One® Main-Link Byte Mode Select (for LINK1) 00 : Reserved 01 : 8bit (3Byte mode) 10 : 10bit (4Byte mode) 11 : Reserved

6.2.2. MPRF (Main-Link PRivate Format)

MPRF format encoding preserves original data packet input to V-by-One® HS transmitter and output the data packet from THCV242. The counterpart transmitter must have installed MPRF format decoder like THCV241 because MPRF is not standard format.

Input V-by-One® HS Byte Mode is 4Byte Mode.

Video formats: RAW8/10/12/14/16/20, YUV422/420, RGB888/666/565, JPEG, and User-defined generic 8-bit are all supported with MPRF.

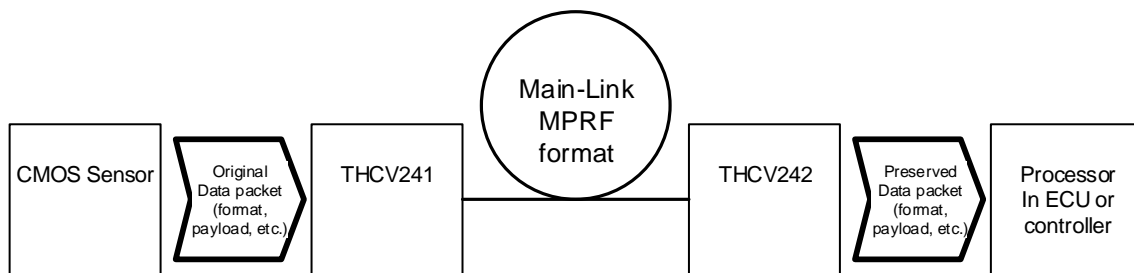

Figure 1. MPRF (Main-Link PRivate Format)

6.2.3. V-by-One® HS standard format

THCV242 input format capabilities as receiver are shown as follows. D[31:0] indicates V-by-One® HS standard version1.5 UnPacker packet definition. Data can be transmitted normally only when both transmitter and receiver are set to the same available format. Some of the THCV242 format may not be supported by particular counterpart transmitter because THCV242 prepares multiple formats that suit to multiple transmitter devices alternatives.

Table 2. V-by-One® HS input data mapping format 1/4

Format Name Vx1HS std. Packer Packet ref.	RGB888	YUV422				
		Normal Mode1	Normal Mode2	Normal Mode3	Demux Mode1	Demux Mode2
V-by-One®HS_D[31]	0	0	0	0	Y[7](1st pixel)	Cb[7]
V-by-One®HS_D[30]	0	0	0	0	Y[6](1st pixel)	Cb[6]
V-by-One®HS_D[29]	0	0	0	0	Y[5](1st pixel)	Cb[5]
V-by-One®HS_D[28]	0	0	0	0	Y[4](1st pixel)	Cb[4]
V-by-One®HS_D[27]	0	0	0	0	Y[3](1st pixel)	Cb[3]
V-by-One®HS_D[26]	0	0	0	0	Y[2](1st pixel)	Cb[2]
V-by-One®HS_D[25]	0	0	0	0	Y[1](1st pixel)	Cb[1]
V-by-One®HS_D[24]	0	0	0	0	Y[0](1st pixel)	Cb[0]
V-by-One®HS_D[23]	B[7]	0	Cb[7]/Cr[7]	Y[7]	Cb[7]	Y[7](1st pixel)
V-by-One®HS_D[22]	B[6]	0	Cb[6]/Cr[6]	Y[6]	Cb[6]	Y[6](1st pixel)
V-by-One®HS_D[21]	B[5]	0	Cb[5]/Cr[5]	Y[5]	Cb[5]	Y[5](1st pixel)
V-by-One®HS_D[20]	B[4]	0	Cb[4]/Cr[4]	Y[4]	Cb[4]	Y[4](1st pixel)
V-by-One®HS_D[19]	B[3]	0	Cb[3]/Cr[3]	Y[3]	Cb[3]	Y[3](1st pixel)
V-by-One®HS_D[18]	B[2]	0	Cb[2]/Cr[2]	Y[2]	Cb[2]	Y[2](1st pixel)
V-by-One®HS_D[17]	B[1]	0	Cb[1]/Cr[1]	Y[1]	Cb[1]	Y[1](1st pixel)
V-by-One®HS_D[16]	B[0]	0	Cb[0]/Cr[0]	Y[0]	Cb[0]	Y[0](1st pixel)
V-by-One®HS_D[15]	G[7]	Y[7]	0	0	Y[7](2nd pixel)	Cr[7]
V-by-One®HS_D[14]	G[6]	Y[6]	0	0	Y[6](2nd pixel)	Cr[6]
V-by-One®HS_D[13]	G[5]	Y[5]	0	0	Y[5](2nd pixel)	Cr[5]
V-by-One®HS_D[12]	G[4]	Y[4]	0	0	Y[4](2nd pixel)	Cr[4]
V-by-One®HS_D[11]	G[3]	Y[3]	0	0	Y[3](2nd pixel)	Cr[3]
V-by-One®HS_D[10]	G[2]	Y[2]	0	0	Y[2](2nd pixel)	Cr[2]
V-by-One®HS_D[9]	G[1]	Y[1]	0	0	Y[1](2nd pixel)	Cr[1]
V-by-One®HS_D[8]	G[0]	Y[0]	0	0	Y[0](2nd pixel)	Cr[0]
V-by-One®HS_D[7]	R[7]	Cb[7]/Cr[7]	Y[7]	Cb[7]/Cr[7]	Cr[7]	Y[7](2nd pixel)
V-by-One®HS_D[6]	R[6]	Cb[6]/Cr[6]	Y[6]	Cb[6]/Cr[6]	Cr[6]	Y[6](2nd pixel)
V-by-One®HS_D[5]	R[5]	Cb[5]/Cr[5]	Y[5]	Cb[5]/Cr[5]	Cr[5]	Y[5](2nd pixel)
V-by-One®HS_D[4]	R[4]	Cb[4]/Cr[4]	Y[4]	Cb[4]/Cr[4]	Cr[4]	Y[4](2nd pixel)
V-by-One®HS_D[3]	R[3]	Cb[3]/Cr[3]	Y[3]	Cb[3]/Cr[3]	Cr[3]	Y[3](2nd pixel)
V-by-One®HS_D[2]	R[2]	Cb[2]/Cr[2]	Y[2]	Cb[2]/Cr[2]	Cr[2]	Y[2](2nd pixel)
V-by-One®HS_D[1]	R[1]	Cb[1]/Cr[1]	Y[1]	Cb[1]/Cr[1]	Cr[1]	Y[1](2nd pixel)
V-by-One®HS_D[0]	R[0]	Cb[0]/Cr[0]	Y[0]	Cb[0]/Cr[0]	Cr[0]	Y[0](2nd pixel)

Table 3. V-by-One® HS input data mapping format 2/4

Format Name Vx1HS std. Packer Packet ref.	RAW8		
	Normal Mode1	Normal Mode2	Demux Mode1
V-by-One®HS_D[31]	0	0	RAW[7] (2nd pixel)
V-by-One®HS_D[30]	0	0	RAW[6] (2nd pixel)
V-by-One®HS_D[29]	0	0	RAW[5] (2nd pixel)
V-by-One®HS_D[28]	0	0	RAW[4] (2nd pixel)
V-by-One®HS_D[27]	0	0	RAW[3] (2nd pixel)
V-by-One®HS_D[26]	0	0	RAW[2] (2nd pixel)
V-by-One®HS_D[25]	0	0	RAW[1] (2nd pixel)
V-by-One®HS_D[24]	0	0	RAW[0] (2nd pixel)
V-by-One®HS_D[23]	0	RAW[7] (1st pixel)	RAW[7] (1st pixel)
V-by-One®HS_D[22]	0	RAW[6] (1st pixel)	RAW[6] (1st pixel)
V-by-One®HS_D[21]	0	RAW[5] (1st pixel)	RAW[5] (1st pixel)
V-by-One®HS_D[20]	0	RAW[4] (1st pixel)	RAW[4] (1st pixel)
V-by-One®HS_D[19]	0	RAW[3] (1st pixel)	RAW[3] (1st pixel)
V-by-One®HS_D[18]	0	RAW[2] (1st pixel)	RAW[2] (1st pixel)
V-by-One®HS_D[17]	0	RAW[1] (1st pixel)	RAW[1] (1st pixel)
V-by-One®HS_D[16]	0	RAW[0] (1st pixel)	RAW[0] (1st pixel)
V-by-One®HS_D[15]	RAW[7] (2nd pixel)	0	RAW[7] (4th pixel)
V-by-One®HS_D[14]	RAW[6] (2nd pixel)	0	RAW[6] (4th pixel)
V-by-One®HS_D[13]	RAW[5] (2nd pixel)	0	RAW[5] (4th pixel)
V-by-One®HS_D[12]	RAW[4] (2nd pixel)	0	RAW[4] (4th pixel)
V-by-One®HS_D[11]	RAW[3] (2nd pixel)	0	RAW[3] (4th pixel)
V-by-One®HS_D[10]	RAW[2] (2nd pixel)	0	RAW[2] (4th pixel)
V-by-One®HS_D[9]	RAW[1] (2nd pixel)	0	RAW[1] (4th pixel)
V-by-One®HS_D[8]	RAW[0] (2nd pixel)	0	RAW[0] (4th pixel)
V-by-One®HS_D[7]	RAW[7] (1st pixel)	RAW[7] (2nd pixel)	RAW[7] (3rd pixel)
V-by-One®HS_D[6]	RAW[6] (1st pixel)	RAW[6] (2nd pixel)	RAW[6] (3rd pixel)
V-by-One®HS_D[5]	RAW[5] (1st pixel)	RAW[5] (2nd pixel)	RAW[5] (3rd pixel)
V-by-One®HS_D[4]	RAW[4] (1st pixel)	RAW[4] (2nd pixel)	RAW[4] (3rd pixel)
V-by-One®HS_D[3]	RAW[3] (1st pixel)	RAW[3] (2nd pixel)	RAW[3] (3rd pixel)
V-by-One®HS_D[2]	RAW[2] (1st pixel)	RAW[2] (2nd pixel)	RAW[2] (3rd pixel)
V-by-One®HS_D[1]	RAW[1] (1st pixel)	RAW[1] (2nd pixel)	RAW[1] (3rd pixel)
V-by-One®HS_D[0]	RAW[0] (1st pixel)	RAW[0] (2nd pixel)	RAW[0] (3rd pixel)

Table 4. V-by-One® HS input data mapping format 3/4

Format Name Vx1HS std. Packer Packet ref.	RAW10		
	Normal	Demux Mode1	Demux Mode2
V-by-One®HS_D[31]	0	0	0
V-by-One®HS_D[30]	0	0	0
V-by-One®HS_D[29]	0	0	0
V-by-One®HS_D[28]	0	0	0
V-by-One®HS_D[27]	0	0	0
V-by-One®HS_D[26]	0	0	0
V-by-One®HS_D[25]	0	RAW[1](1st pixel)	0
V-by-One®HS_D[24]	0	RAW[0](1st pixel)	0
V-by-One®HS_D[23]	0	RAW[9](1st pixel)	0
V-by-One®HS_D[22]	0	RAW[8](1st pixel)	0
V-by-One®HS_D[21]	0	RAW[7](1st pixel)	RAW[1](1st pixel)
V-by-One®HS_D[20]	0	RAW[6](1st pixel)	RAW[0](1st pixel)
V-by-One®HS_D[19]	0	RAW[5](1st pixel)	RAW[9](1st pixel)
V-by-One®HS_D[18]	0	RAW[4](1st pixel)	RAW[8](1st pixel)
V-by-One®HS_D[17]	0	RAW[3](1st pixel)	RAW[7](1st pixel)
V-by-One®HS_D[16]	0	RAW[2](1st pixel)	RAW[6](1st pixel)
V-by-One®HS_D[15]	0	0	RAW[5](1st pixel)
V-by-One®HS_D[14]	0	0	RAW[4](1st pixel)
V-by-One®HS_D[13]	0	0	RAW[3](1st pixel)
V-by-One®HS_D[12]	0	0	RAW[2](1st pixel)
V-by-One®HS_D[11]	0	0	0
V-by-One®HS_D[10]	0	0	0
V-by-One®HS_D[9]	RAW[1]	RAW[1](2nd pixel)	RAW[1](2nd pixel)
V-by-One®HS_D[8]	RAW[0]	RAW[0](2nd pixel)	RAW[0](2nd pixel)
V-by-One®HS_D[7]	RAW[9]	RAW[9](2nd pixel)	RAW[9](2nd pixel)
V-by-One®HS_D[6]	RAW[8]	RAW[8](2nd pixel)	RAW[8](2nd pixel)
V-by-One®HS_D[5]	RAW[7]	RAW[7](2nd pixel)	RAW[7](2nd pixel)
V-by-One®HS_D[4]	RAW[6]	RAW[6](2nd pixel)	RAW[6](2nd pixel)
V-by-One®HS_D[3]	RAW[5]	RAW[5](2nd pixel)	RAW[5](2nd pixel)
V-by-One®HS_D[2]	RAW[4]	RAW[4](2nd pixel)	RAW[4](2nd pixel)
V-by-One®HS_D[1]	RAW[3]	RAW[3](2nd pixel)	RAW[3](2nd pixel)
V-by-One®HS_D[0]	RAW[2]	RAW[2](2nd pixel)	RAW[2](2nd pixel)

Table 5. V-by-One® HS input data mapping format 4/4

Format Name Vx1HS std. Packer Packet ref.	RAW12		
	Normal	Demux Mode1	Demux Mode2
V-by-One®HS_D[31]	0	0	0
V-by-One®HS_D[30]	0	0	0
V-by-One®HS_D[29]	0	0	0
V-by-One®HS_D[28]	0	0	0
V-by-One®HS_D[27]	0	RAW[3](1st pixel)	0
V-by-One®HS_D[26]	0	RAW[2](1st pixel)	0
V-by-One®HS_D[25]	0	RAW[1](1st pixel)	0
V-by-One®HS_D[24]	0	RAW[0](1st pixel)	0
V-by-One®HS_D[23]	0	RAW[11](1st pixel)	RAW[3](1st pixel)
V-by-One®HS_D[22]	0	RAW[10](1st pixel)	RAW[2](1st pixel)
V-by-One®HS_D[21]	0	RAW[9](1st pixel)	RAW[1](1st pixel)
V-by-One®HS_D[20]	0	RAW[8](1st pixel)	RAW[0](1st pixel)
V-by-One®HS_D[19]	0	RAW[7](1st pixel)	RAW[11](1st pixel)
V-by-One®HS_D[18]	0	RAW[6](1st pixel)	RAW[10](1st pixel)
V-by-One®HS_D[17]	0	RAW[5](1st pixel)	RAW[9](1st pixel)
V-by-One®HS_D[16]	0	RAW[4](1st pixel)	RAW[8](1st pixel)
V-by-One®HS_D[15]	0	0	RAW[7](1st pixel)
V-by-One®HS_D[14]	0	0	RAW[6](1st pixel)
V-by-One®HS_D[13]	0	0	RAW[5](1st pixel)
V-by-One®HS_D[12]	0	0	RAW[4](1st pixel)
V-by-One®HS_D[11]	RAW[3]	RAW[3](2nd pixel)	RAW[3](2nd pixel)
V-by-One®HS_D[10]	RAW[2]	RAW[2](2nd pixel)	RAW[2](2nd pixel)
V-by-One®HS_D[9]	RAW[1]	RAW[1](2nd pixel)	RAW[1](2nd pixel)
V-by-One®HS_D[8]	RAW[0]	RAW[0](2nd pixel)	RAW[0](2nd pixel)
V-by-One®HS_D[7]	RAW[11]	RAW[11](2nd pixel)	RAW[11](2nd pixel)
V-by-One®HS_D[6]	RAW[10]	RAW[10](2nd pixel)	RAW[10](2nd pixel)
V-by-One®HS_D[5]	RAW[9]	RAW[9](2nd pixel)	RAW[9](2nd pixel)
V-by-One®HS_D[4]	RAW[8]	RAW[8](2nd pixel)	RAW[8](2nd pixel)
V-by-One®HS_D[3]	RAW[7]	RAW[7](2nd pixel)	RAW[7](2nd pixel)
V-by-One®HS_D[2]	RAW[6]	RAW[6](2nd pixel)	RAW[6](2nd pixel)
V-by-One®HS_D[1]	RAW[5]	RAW[5](2nd pixel)	RAW[5](2nd pixel)
V-by-One®HS_D[0]	RAW[4]	RAW[4](2nd pixel)	RAW[4](2nd pixel)

6.2.4. Link Status (HTPDN/LOCKN)

Hot-Plug Function

HTPDN indicates Main-Link connect condition between Transmitter and Receiver. HTPDN of Transmitter side is high when Receiver is not active or not connected. Then Transmitter can enter into power down mode. HTPDN is set to Low by the Receiver when Receiver is active and connects to the Transmitter, and then Transmitter must start up and transmit CDR training pattern for link training. HTPDN is open drain output at the receiver side. Transmitter side needs Pull-up resistor.

There is an application option to omit HTPDN connection between Transmitter and Receiver. In this case, HTPDN at Transmitter side should always be at Low.

Lock Detect Function

LOCKN indicates whether CDR PLL of Main-Link is in lock status or not. LOCKN at Transmitter input is set to High by pull-up resistor when Receiver is not active or in CDR PLL training. LOCKN is set to Low by Receiver when CDR lock is completed. After that the CDR training mode finishes and then Transmitter shifts to the normal mode. LOCKN of Receiver is open drain. Transmitter side needs pull-up resistor.

When an application omits HTPDN, LOCKN signal should only be considered with HTPDN pulled low by Receiver.

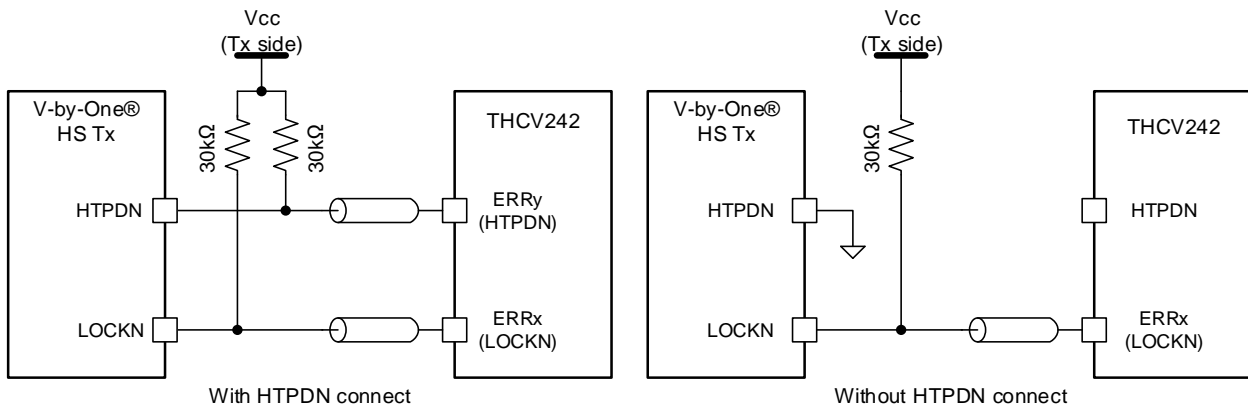

Figure 2. Physical wire connection for wired Hot-plug and Lock detect scheme

It will need same GND potential reference between transmitter and receiver device to connect HTPDN and LOCKN pins directly like above. HTPDN and LOCKN can also be transmitted via Sub-Link without physical wire connection. Assignment can be configurable by 2-wire access to internal register.

Table 6. HTPDN/LOCKN register

Addr(h)	bit	Register Name	width	R/W	Description	Default
0x0019	[7:4]	ReservedL	4	RW	Must be set 0	4'd0
	[3:2]	R_LOCKN_LN1_SEL	2	RW	Sub-Link Lane1 LOCKN/HTPDN scheme of releted Main-Link select 0:LOCKN1 1:LOCKN0 LOCKN1 2:Reserved 3:1'b0 (Forced LOCKN/HTPDN=Low) *LOCKN1=LOCKN signal of V-by-One(R) HS Lane1=RX1P/RX1N *HTPDN of the same lane as above set LOCKN lane is used	2'd0
	[1:0]	R_LOCKN_LN0_SEL	2	RW	Sub-Link Lane0 LOCKN/HTPDN scheme of releted Main-Link select 0:LOCKN0 1:LOCKN0 LOCKN1 2:Reserved 3:1'b0 (Forced LOCKN/HTPDN=Low) *LOCKN0=LOCKN signal of V-by-One(R) HS Lane0=RX0P/RX0N *HTPDN of the same lane as above set LOCKN lane is used	2'd0

6.3. Local, Remote and Remote Slave Register Programming

6.3.1. 2-wire serial I/F slave Device ID

To use basic functions, initialization, GPIO (General Purpose Input/Output), fault/error detection, and interrupt function, 2-wire serial I/F enables to access registers. AIN<1:0> pin determines 2-wire slave Device ID setting.

Table 7. 2-wire serial I/F Device ID select by AIN pin

AIN1	37	11	Device Address Setting for 2-wire Serial Interface [AIN1:AIN0]=00: ID=7'h0B [AIN1:AIN0]=01: ID=7'h34 [AIN1:AIN0]=10: ID=7'h77 [AIN1:AIN0]=11: ID=7'h65
AIN0	36	11	

As an additional method, 2-wire slave Device ID setting can be changed from default value by register setting.

Table 8. 2-wire serial I/F Device ID select by register setting

Addr(h)	bit	Register Name	width	R/W	Description	Default
0x0030	[7:0]	R_2WIRE_SADR	8	RW	2WIRE slave device address setting [7]2WIRE slave device address control 0: 2WIRE slv device addr. is set by AIN<1:0> pin 1: 2WIRE slv device addr. is set by following register [6:0] [6:0]2WIRE slave device address value for register control	8'd0

6.3.2. 2-wire serial Read/Write access to local Register

HOST MPU can directly access THCV242 local register by 2-wire serial I/F.

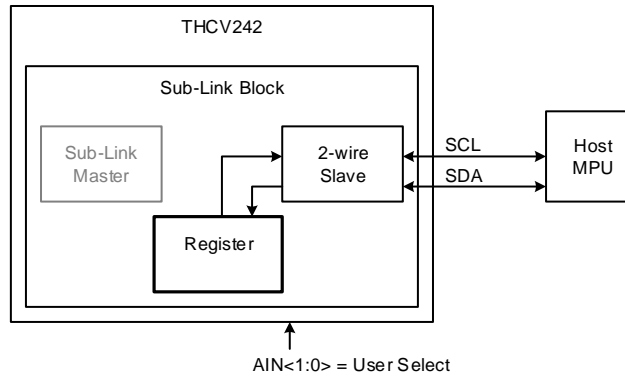

Figure 3. Host to THCV242 local register access configuration

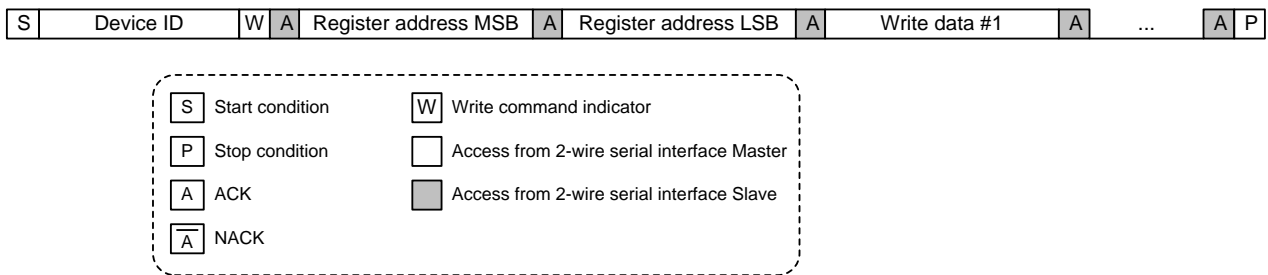

Figure 4. 2-wire serial I/F write to THCV242 local register protocol

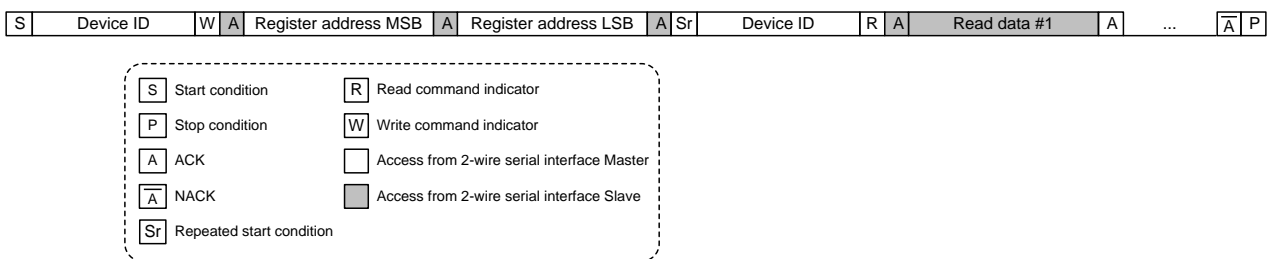

Figure 5. 2-wire serial I/F read to THCV242 local register protocol

6.3.3. 2-wire serial I/F Watch Dog Timer

2-wire Watch Dog Timer (WDT) is installed to monitor status.

Table 9. 2-wire WDT setting

Addr(h)	bit	Register Name	width	R/W	Description	Default
0x003B	[7:5]	reserved	3	-	-	-
	[4]	R_2WIRE_WD_EN	1	RW	2WIRE WDT Enable 0:Disable 1:Enable	1'b1
	[3:1]	reserved	3	-	-	-
	[0]	R_2WIRE_WD_OFFSET	1	RW	2WIRE_WDT_OffsetTime 1:11'd2047 0:11'd1023	1'd1
0x003C	[7:0]	R_2WIRE_WD_TIM	8	RW	2WIRE WDT_time=64x{(R_2WIRE_WD_TIM<7:0>+1)}x{2WIRE_WDT_OffsetTime}xtOSC	8'd255

6.3.4. Sub-Link setting

THCV242 has Sub-Link which enables bi-directional transmission of 2-wire serial interface signals, GPIO signals and also HTPDN/LOCKN signals for Main-Link. THCV242 is Sub-Link Master and connectable to Sub-Link Slave device such as THCV241.

Sub-Link Polling interval is controllable from about 20us to 800us, that may have relationships on fault/error detection, interrupt, or other UART / GPIO transfer time designed on application. SSR (Sub-Link Status Read) interval determines recovery quickness from 2-wire serial remote communication completion. SSR interval effects only on Sub-Link Master “2-wire Set&Trigger mode1” (R_SLINK_MODE setting).

Table 10. Sub-Link Master protocol basic setting

Addr(h)	bit	Register Name	width	R/W	Description	Default
0x0004	[7:3]	reserved	5	-	-	-
	[2:0]	R_SLINK_MODE	3	RW	Sub-Link basic protocol setting as Sub-Link Master 1: 2-wire Set&Trigger (Normal) mode1 3: 2-wire Pass Through mode1 0,2,4,5,6,7: Reserved	3'd1
0x0010	[7:4]	R_SLINK_EN	4	RW	Sub-Link Enable [7] Reserved [6] Reserved [5] 0: Lane1 Disable, 1: Lane1 Enable [4] 0: Lane0 Disable, 1: Lane0 Enable	4'd0
	[3:0]	R_SLINK_POL_EN	4	RW	Sub-Link Polling Enable [3] Reserved [2] Reserved [1] 0: Lane1 Disable, 1: Lane1 Enable [0] 0: Lane0 Disable, 1: Lane0 Enable	4'hF
0x0011	[7:4]	R_SLINK_SSR_EN	4	RW	Sub-Link SSR Enable [7] Reserved [6] Reserved [5] 0: Lane1 Disable, 1: Lane1 Enable [4] 0: Lane0 Disable, 1: Lane0 Enable	4'hF
	[3:0]	R_SLINK_WD_EN	4	RW	Sub-Link WDT Enable [3] Reserved [2] Reserved [1] 0: Lane1 Disable, 1: Lane1 Enable [0] 0: Lane0 Disable, 1: Lane0 Enable	4'hF
0x001A	[7:5]	reserved	3	-	-	-
	[4]	R_SLINK_POL_OFFSET_EN	1	RW	Sub-Link Polling Offset Enable 0: Disable 1: Enable, Polling time phase of each lanes are shifted as below lane1 offset from lane0: Sub-Link Poling interval x 1/4	1'b0
	[3:2]	reserved	2	-	-	-
	[1:0]	R_SLINK_POL_TIM_UP	2	RW	Sub-Link Polling interval setting (min. 0x018, about 20us)	2'd0
0x001B	[7:0]	R_SLINK_POL_TIM_DN	8	RW	Sub-Link Polling interval time=64x(256xR_SLINK_POL_TIM_UP<1:0>+R_SLINK_POL_TIM_DN<7:0>+1)xTOSC *No Polling when R_SLINK_POL_TIM_UP=0 and R_SLINK_POL_TIM_DN=0	8'd124
0x001C	[7:2]	reserved	6	-	-	-
	[1:0]	R_SLINK_SSR_TIM_UP	2	RW	Sub-Link SSR interval setting	2'd0
0x001D	[7:0]	R_SLINK_SSR_TIM_DN	8	RW	Sub-Link SSR interval time=64x(256xR_SLINK_SSR_TIM_UP<1:0>+R_SLINK_SSR_TIM_DN<7:0>+1)xTOSC *No SSR when R_SLINK_SSR_TIM_UP=0 and R_SLINK_SSR_TIM_DN=0	8'd249

To use GPIO (General Purpose Input/Output) pin, fault/error detection and interrupt function, “2-wire Set&Trigger mode1”, “2-wire Pass Through mode1” enables remote register access. THCV242, Sub-Link Master device has 2-wire serial slave block and can connect to HOST MPU. On the other hand, the counterpart Sub-Link Slave device has 2-wire serial master block and can connect to remote side 2-wire serial slave devices.

HOST MPU can access register of Sub-Link Master device, Sub-Link Slave device and remote side 2-wire serial slave devices.

6.3.5. Sub-Link 2-wire Read/Write access to remote Register

6.3.5.1. Sub-Link 2-wire Set and Trigger mode

HOST MPU can access to Sub-Link Slave's register via THCV242 as Sub-Link Master only by THCV242 internal local register control and monitoring on 2-wire Set&Trigger mode1.

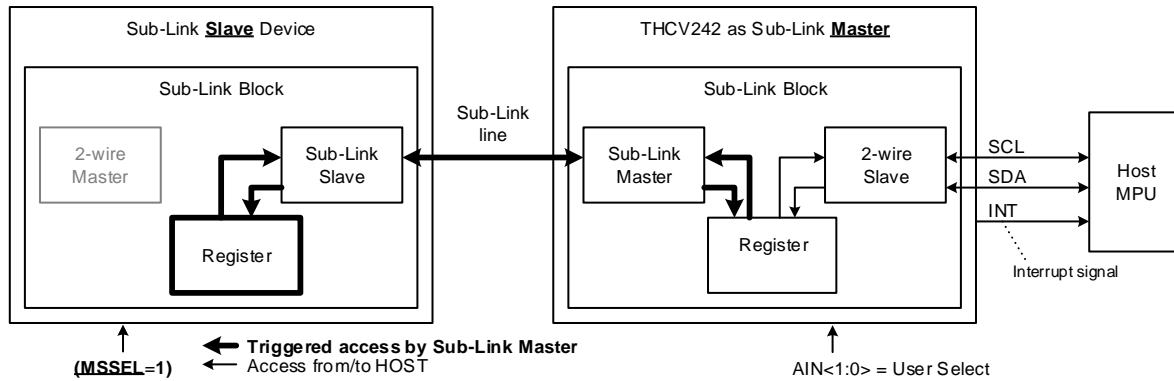

Figure 6. Host MPU to Sub-Link Slave Register via THCV242 access configuration

HOST MPU can access to remote side 2-wire serial slave register via THCV242 as Sub-Link Master only by THCV242 internal local register control and monitoring on 2-wire Set&Trigger mode1.

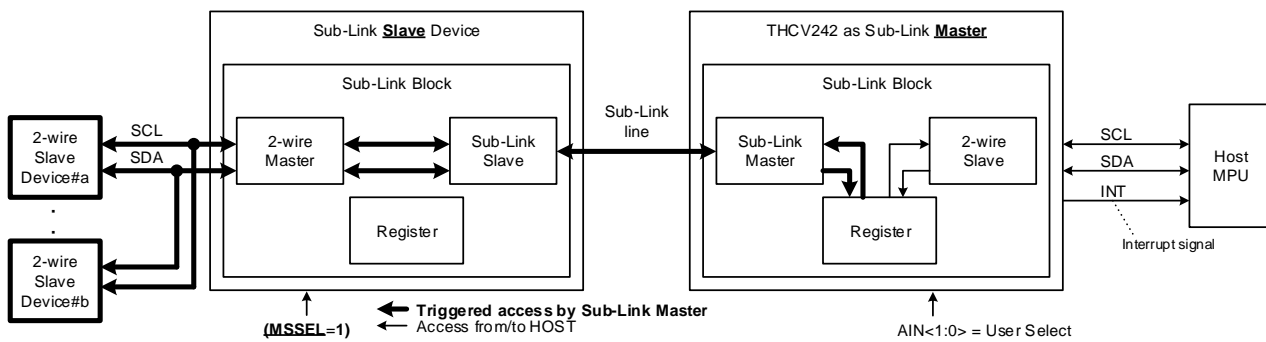

Figure 7. Host MPU to remote 2-wire slave devices via THCV242 access configuration

In principle, when Sub-Link bridges 2-wire serial interface communication from Sub-Link Master to Sub-Link Slave or remote side 2-wire serial slave devices, time lag occurs between HOST MPU side 2-wire serial access and Sub-Link Slave internal bus access or remote side 2-wire serial access.

R_2WIRE_CLKSEN (Sub-Link Master side register, 0x0042 bit0) selects whether 2-wire serial slave of Sub-Link Master perform clock stretching.

When R_2WIRE_CLKSEN = 1, Sub-Link Master device waits HOST MPU until Sub-Link Slave register access or remote side 2-wire serial slave register access complete by clock stretching.

When R_2WIRE_CLKSEN = 0, Sub-Link Master device informs HOST MPU that Sub-Link Slave register access or remote side 2-wire serial register access has completed by interruption (detectable on INT pin) without clock stretching.

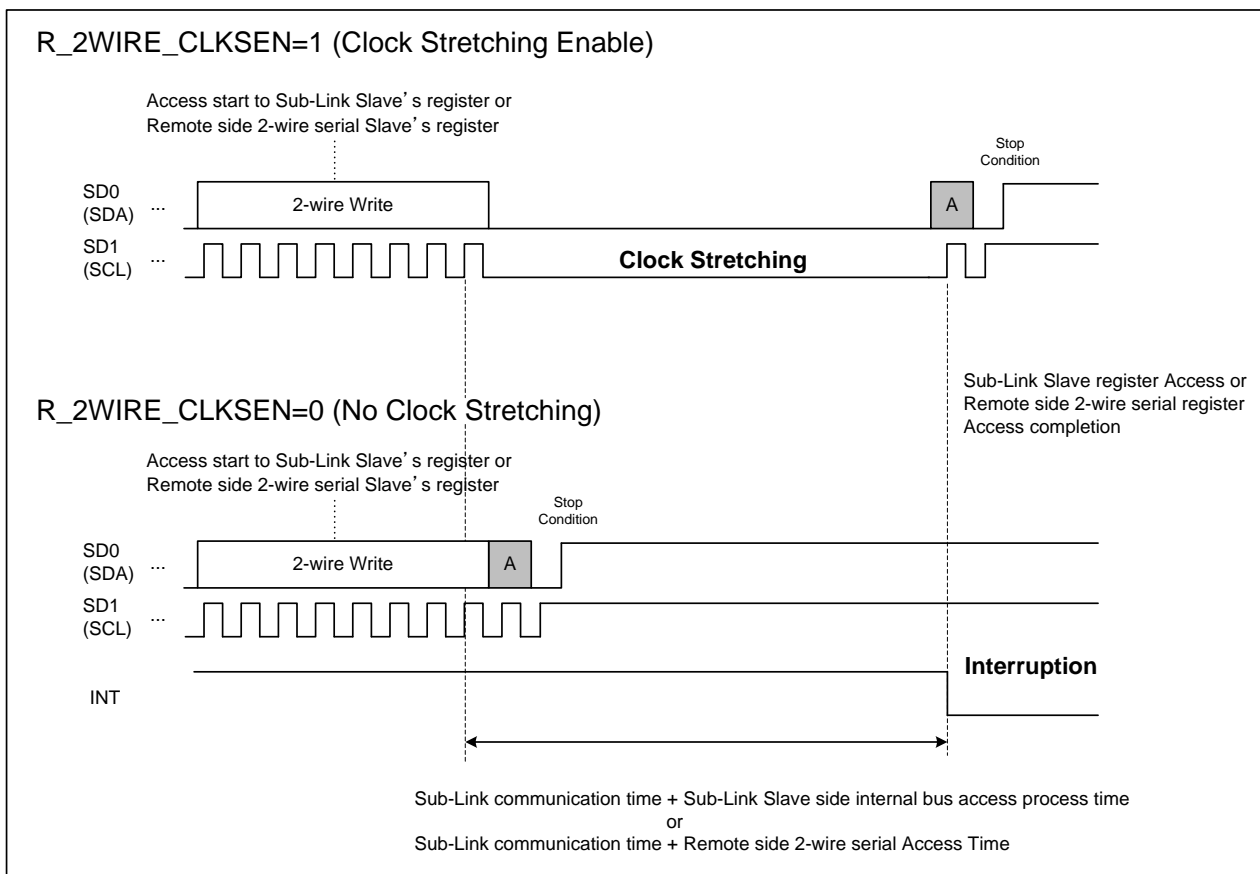

Figure 8. Sub-Link Master 2-wire slave clock stretching operation

Table 11. 2-wire serial I/F Set& Trigger mode remote access control and monitoring local registers

Addr(h)	bit	Register Name	width	R/W	Description	Default
0x00D0	[7:0]	R_2WIRE_DATA0	8	RW	2-wire serial I/F remote write/read data #0	8'd0
0x00D1	[7:0]	R_2WIRE_DATA1	8	RW	2-wire serial I/F remote write/read data #1	8'd0
0x00D2	[7:0]	R_2WIRE_DATA2	8	RW	2-wire serial I/F remote write/read data #2	8'd0
0x00D3	[7:0]	R_2WIRE_DATA3	8	RW	2-wire serial I/F remote write/read data #3	8'd0
0x00D4	[7:0]	R_2WIRE_DATA4	8	RW	2-wire serial I/F remote write/read data #4	8'd0
0x00D5	[7:0]	R_2WIRE_DATA5	8	RW	2-wire serial I/F remote write/read data #5	8'd0
0x00D6	[7:0]	R_2WIRE_DATA6	8	RW	2-wire serial I/F remote write/read data #6	8'd0
0x00D7	[7:0]	R_2WIRE_DATA7	8	RW	2-wire serial I/F remote write/read data #7	8'd0
0x00D8	[7:0]	R_2WIRE_DATA8	8	RW	2-wire serial I/F remote write/read data #8	8'd0
0x00D9	[7:0]	R_2WIRE_DATA9	8	RW	2-wire serial I/F remote write/read data #9	8'd0
0x00DA	[7:0]	R_2WIRE_DATA10	8	RW	2-wire serial I/F remote write/read data #10	8'd0
0x00DB	[7:0]	R_2WIRE_DATA11	8	RW	2-wire serial I/F remote write/read data #11	8'd0
0x00DC	[7:0]	R_2WIRE_DATA12	8	RW	2-wire serial I/F remote write/read data #12	8'd0
0x00DD	[7:0]	R_2WIRE_DATA13	8	RW	2-wire serial I/F remote write/read data #13	8'd0
0x00DE	[7:0]	R_2WIRE_DATA14	8	RW	2-wire serial I/F remote write/read data #14	8'd0
0x00DF	[7:0]	R_2WIRE_DATA15	8	RW	2-wire serial I/F remote write/read data #15	8'd0
0x00E0	[7:1]	R_2WIRE_DEVADR	7	RW	2-wire serial I/F remote access target device address. if target=self addr.; access to Sub-Link Slave inside register, else; access to remote side 2-wire serial Slave devices externally connected to Sub-Link slave	7'h00
	[0]	R_2WIRE_WR	1	RW	2-wire serial I/F remote access write or read select 0:Write 1:Read	1'b0
0x00E1	[7]	reserved	1	-	-	-
	[6:4]	R_2WIRE_WADR_BYTE	3	RW	2-wire serial I/F remote device's Sub Address (Word Address, register address) Byte width select. address Byte width=R_2WIRE_WADR_BYTE<2:0>+1 0 : 1Byte= 8bit Sub addr.(register addr.) 1 : 2Byte=16bit Sub addr.(register addr.) 4 : 5Byte=40bit Sub addr.(register addr.), etc.	3'd0
	[3:0]	R_2WIRE_DATA_BYTE	4	RW	2-wire serial I/F remote access data Byte number Byte Number = R_2WIRE_DATA_BYTE + 1 (e.g. 0x2 for 3byte burst) [write rule] R_2WIRE_WADR_BYTE+R_2WIRE_DATA_BYTE < 'd16 [read rule] R_2WIRE_DATA_BYTE<'d16	4'd0
0x00E2	[7:1]	reserved	7	-	-	-
	[0]	R_2WIRE_CLKSEN	1	RW	2-wire serial I/F local response clock stretching Enable 0: Sub-Link Master (2-wire slave) No clock stretching 1: Sub-Link Master (2-wire slave) clock stretching Enable *2-wire Pass Through mode forces clock stretching Enable	1'b0
0x00E3	[7:2]	reserved	6	-	-	-
	[1:0]	R_2WIRE_RD_LANE_SEL	2	RW	Sub-Link transaction read lane select 0: Lane0 Sub-Link read 1: Lane1 Sub-Link read 2,3: Reserved	2'd0
0x00E4	[7:2]	reserved	4	-	-	-
	[1:0]	R_2WIRE_WR_LANE_SEL	4	RW	Sub-Link transaction write lane select [1] 0: Lane1 Disable, 1: Lane1 Enable [0] 0: Lane0 Disable, 1: Lane0 Enable *Only active when R_SLINK_MODE=4'd0 or 4'd1	4'hF
0x00E5	[7:1]	reserved	7	-	-	-
	[0]	R_2WIRE_START	1	W	2-wire serial I/F remote access start trigger	-

6.3.5.2. Sub-Link 2-wire Pass Through mode

Sub-Link Master 2-wire Pass Through mode1 can bridge original local 2-wire commands to remote side basically with no logical change.

2-wire Pass Through mode1 uses 2-wire slave clock stretching scheme at local Sub-Link Master side. Host MCU 2-wire master must be no problem with clock stretching wait from 2-wire slave.

Sub-Link Slave side processing protocol “Divided write/read” scheme divides 2-wire commands into determined data Byte groups. Each data Byte groups are sent separately on remote side. Burst write/read access target Sub-Address (Word-Address) is interpreted so that subsequent Sub-Address (Word-Address) from 2nd group is automatically and properly incremented. As shown below, remote side 2-wire accesses are independent each other by determined Byte, which are defined in R_2WIREPT_WA_BYTE and R_2WIREPT_DATA_BYTE at R_2WIREPT1_PASS_MODE[1]=1.

Divided write access at R_2WIREPT1_PASS_MODE[1]=1 (case: 1Byte Word Address and 16Byte burst 2-wire write with R_2WIREPT_WA_BYTE=3'd1 and R_2WIREPT_DATA_BYTE=4'd8)

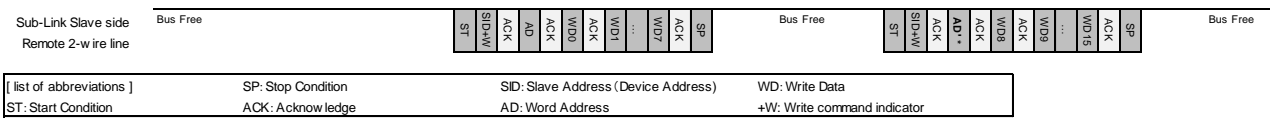

Figure 9. 2-wire Pass Through mode1 Sub-Link Slave command Divided scheme

On address processing protocol “Assigned address & rename”, THCV242 2-wire slave respond only to 2-wire device address defined in R_2WIREPT1_PASS_ADRxy1 (x=Lane0 or Lane1, y=0/1/2/3) for remote Pass Through operation. Otherwise, 2-wire commands are ignored except THCV242 itself address. The device address can be renamed before remote send. The counterpart Sub-Link Slave internal register access is available with R_2WIREPT1_PASS_ADRINx (x=Lane0 or Lane1) setting.

On address processing protocol “All Through”, THCV242 2-wire slave respond basically all 2-wire device address for remote Pass Through operation except THCV242 itself address. Additionally, Defined addresses in R_2WIREPT2_NOPASS_ADRxz (x=Lane0 or Lane1, z=0/1/2/3/4/5/6/7) can be ignored by THCV242.

Table 12. 2-wire serial I/F Pass Through mode remote access setting 1/2

Addr(h)	bit	Register Name	width	R/W	Description	Default
0x0031	[7:2]	reserved	6	-	-	-
	[1:0]	R_2WIREPT_MODE	2	RW	2WIRE Pass Through mode setting [1]Pass Through processing protocol on Sub-Link Slave 0:Reserved 1:Divided write & Divided read** (available with 2-wire Pass Through mode1) **:Transaction address and data Byte number is set as R_2WIREPT_WA_BYTE and R_2WIREPT_DATA_BYTE. [0]Pass Through 2WIRE device address processing 0:Address rename (rule as R_2WIREPT1_PASS_ADRxy0/1. x is Lane0or1, y=<3:0>) 1:All Through (exception definition of address to ignore as R_2WIREPT2_NOPASS_ADRxz. x is Lane0or1, z=<7:0>)	2'd0
0x0032	[7]	reserved	1	-	-	-
	[6:4]	R_2WIREPT_WA_BYTE	3	RW	2WIRE Pass Through Divided write/read Sub-Address (Word Address) Byte number setting, being active only at R_2WIREPT1_PASS_MODE[1]=1 Byte Number = R_2WIREPT_WA_BYTE + 1 (e.g. 0x1 for 2Byte Sub-Address) *R_2WIREPT_WA_BYTE + R_2WIREPT_DATA_BYTE < 14 is required.	3'd0
	[3:0]	R_2WIREPT_DATA_BYTE	4	RW	2WIRE Pass Through Divided write/read data Byte number per one transaction setting, being active only at R_2WIREPT1_PASS_MODE[1]=1 Byte Number = R_2WIREPT_DATA_BYTE + 1 (e.g. 0x2 for 3Byte per transaction) *R_2WIREPT_WA_BYTE + R_2WIREPT_DATA_BYTE < 14 is required.	4'd0
0x0040	[7:0]	R_2WIREPT1_PASS_ADR000	8	RW	2WIRE Pass Through received "before rename" address for Lane0 #0, being active only at R_2WIREPT_MODE[0]=0.	8'd0
0x0041	[7:0]	R_2WIREPT1_PASS_ADR001	8	RW	2WIRE Pass Through "after renamed" address to send for Lane0 #0, being active only at R_2WIREPT_MODE[0]=0.	8'd0
0x0042	[7:0]	R_2WIREPT1_PASS_ADR010	8	RW	2WIRE Pass Through received "before rename" address for Lane0 #1, being active only at R_2WIREPT_MODE[0]=0.	8'd0
0x0043	[7:0]	R_2WIREPT1_PASS_ADR011	8	RW	2WIRE Pass Through "after renamed" address to send for Lane0 #1, being active only at R_2WIREPT_MODE[0]=0.	8'd0
0x0044	[7:0]	R_2WIREPT1_PASS_ADR020	8	RW	2WIRE Pass Through received "before rename" address for Lane0 #2, being active only at R_2WIREPT_MODE[0]=0.	8'd0
0x0045	[7:0]	R_2WIREPT1_PASS_ADR021	8	RW	2WIRE Pass Through "after renamed" address to send for Lane0 #2, being active only at R_2WIREPT_MODE[0]=0.	8'd0
0x0046	[7:0]	R_2WIREPT1_PASS_ADR030	8	RW	2WIRE Pass Through received "before rename" address for Lane0 #3, being active only at R_2WIREPT_MODE[0]=0.	8'd0
0x0047	[7:0]	R_2WIREPT1_PASS_ADR031	8	RW	2WIRE Pass Through "after renamed" address to send for Lane0 #3, being active only at R_2WIREPT_MODE[0]=0.	8'd0
0x0048	[7:0]	R_2WIREPT2_NOPASS_ADR00	8	RW	2WIRE Pass Through ignore address /otherwise All Through for Lane0 #0, being active only at R_2WIREPT_MODE[0]=1.	8'd0
0x0049	[7:0]	R_2WIREPT2_NOPASS_ADR01	8	RW	2WIRE Pass Through ignore address /otherwise All Through for Lane0 #1, being active only at R_2WIREPT_MODE[0]=1.	8'd0
0x004A	[7:0]	R_2WIREPT2_NOPASS_ADR02	8	RW	2WIRE Pass Through ignore address /otherwise All Through for Lane0 #2, being active only at R_2WIREPT_MODE[0]=1.	8'd0
0x004B	[7:0]	R_2WIREPT2_NOPASS_ADR03	8	RW	2WIRE Pass Through ignore address /otherwise All Through for Lane0 #3, being active only at R_2WIREPT_MODE[0]=1.	8'd0
0x004C	[7:0]	R_2WIREPT2_NOPASS_ADR04	8	RW	2WIRE Pass Through ignore address /otherwise All Through for Lane0 #4, being active only at R_2WIREPT_MODE[0]=1.	8'd0
0x004D	[7:0]	R_2WIREPT2_NOPASS_ADR05	8	RW	2WIRE Pass Through ignore address /otherwise All Through for Lane0 #5, being active only at R_2WIREPT_MODE[0]=1.	8'd0
0x004E	[7:0]	R_2WIREPT2_NOPASS_ADR06	8	RW	2WIRE Pass Through ignore address /otherwise All Through for Lane0 #6, being active only at R_2WIREPT_MODE[0]=1.	8'd0
0x004F	[7:0]	R_2WIREPT2_NOPASS_ADR07	8	RW	2WIRE Pass Through ignore address /otherwise All Through for Lane0 #7, being active only at R_2WIREPT_MODE[0]=1.	8'd0
0x0050	[7:0]	R_2WIREPT1_PASS_ADRIN0	8	RW	2WIRE Pass Through counterpart Sub-Link Slave internal access dedicated address for Lane0, being active only at R_2WIREPT_MODE[0]=0.	8'd0

Table 13. 2-wire serial I/F Pass Through mode remote access setting 2/2

Addr(h)	bit	Register Name	width	R/W	Description	Default
0x0060	[7:0]	R_2WIREPT1_PASS_ADR100	8	RW	2WIRE Pass Through received "before rename" address for Lane1 #0, being active only at R_2WIREPT_MODE[0]=0.	8'd0
0x0061	[7:0]	R_2WIREPT1_PASS_ADR101	8	RW	2WIRE Pass Through "after renamed" address to send for Lane1 #0, being active only at R_2WIREPT_MODE[0]=0.	8'd0
0x0062	[7:0]	R_2WIREPT1_PASS_ADR110	8	RW	2WIRE Pass Through received "before rename" address for Lane1 #1, being active only at R_2WIREPT_MODE[0]=0.	8'd0
0x0063	[7:0]	R_2WIREPT1_PASS_ADR111	8	RW	2WIRE Pass Through "after renamed" address to send for Lane1 #1, being active only at R_2WIREPT_MODE[0]=0.	8'd0
0x0064	[7:0]	R_2WIREPT1_PASS_ADR120	8	RW	2WIRE Pass Through received "before rename" address for Lane1 #2, being active only at R_2WIREPT_MODE[0]=0.	8'd0
0x0065	[7:0]	R_2WIREPT1_PASS_ADR121	8	RW	2WIRE Pass Through "after renamed" address to send for Lane1 #2, being active only at R_2WIREPT_MODE[0]=0.	8'd0
0x0066	[7:0]	R_2WIREPT1_PASS_ADR130	8	RW	2WIRE Pass Through received "before rename" address for Lane1 #3, being active only at R_2WIREPT_MODE[0]=0.	8'd0
0x0067	[7:0]	R_2WIREPT1_PASS_ADR131	8	RW	2WIRE Pass Through "after renamed" address to send for Lane1 #3, being active only at R_2WIREPT_MODE[0]=0.	8'd0
0x0068	[7:0]	R_2WIREPT2_NOPASS_ADR10	8	RW	2WIRE Pass Through ignore address /otherwise All Through for Lane1 #0, being active only at R_2WIREPT_MODE[0]=1.	8'd0
0x0069	[7:0]	R_2WIREPT2_NOPASS_ADR11	8	RW	2WIRE Pass Through ignore address /otherwise All Through for Lane1 #1, being active only at R_2WIREPT_MODE[0]=1.	8'd0
0x006A	[7:0]	R_2WIREPT2_NOPASS_ADR12	8	RW	2WIRE Pass Through ignore address /otherwise All Through for Lane1 #2, being active only at R_2WIREPT_MODE[0]=1.	8'd0
0x006B	[7:0]	R_2WIREPT2_NOPASS_ADR13	8	RW	2WIRE Pass Through ignore address /otherwise All Through for Lane1 #3, being active only at R_2WIREPT_MODE[0]=1.	8'd0
0x006C	[7:0]	R_2WIREPT2_NOPASS_ADR14	8	RW	2WIRE Pass Through ignore address /otherwise All Through for Lane1 #4, being active only at R_2WIREPT_MODE[0]=1.	8'd0
0x006D	[7:0]	R_2WIREPT2_NOPASS_ADR15	8	RW	2WIRE Pass Through ignore address /otherwise All Through for Lane1 #5, being active only at R_2WIREPT_MODE[0]=1.	8'd0
0x006E	[7:0]	R_2WIREPT2_NOPASS_ADR16	8	RW	2WIRE Pass Through ignore address /otherwise All Through for Lane1 #6, being active only at R_2WIREPT_MODE[0]=1.	8'd0
0x006F	[7:0]	R_2WIREPT2_NOPASS_ADR17	8	RW	2WIRE Pass Through ignore address /otherwise All Through for Lane1 #7, being active only at R_2WIREPT_MODE[0]=1.	8'd0
0x0070	[7:0]	R_2WIREPT1_PASS_ADRIN1	8	RW	2WIRE Pass Through counterpart Sub-Link Slave internal access dedicated address for Lane1, being active only at R_2WIREPT_MODE[0]=0.	8'd0

6.3.6. Sub-Link transaction time accuracy Improvement

Sub-Link Polling timing can be controllable by GPI input. All Sub-Link lane transaction timing can be arranged.

Table 14. Sub-Link transaction time accuracy control

Addr(h)	bit	Register Name	width	R/W	Description	Default
0x0016	[7:6]	reserved	2	-	-	-
	[5:4]	R_POL_TIM_CLR_EN	2	RW	Polling Timer Clear/Mask Enable 0:Disable 1:Polling Timer Clear by GPI mode Enable 2:Polling Timer Mask by GPI mode Enable 3:Disable	2'd0
	[3]	reserved	1	-	-	-
	[2:0]	R_GPI_TRG_SEL	3	RW	Polling Timer Clear/Mask GPI select 0:GPI0, 1:GPI1, 2:GPI2, 3:GPI3, 4:GPI4, 5:GPI5, 6:GPI6, 7:GPI7 *Only 0and1 are available at 2-wire mode1 (R_SLINK_MODE[1:0]=2'd1)	3'd0

Polling Timer Clear

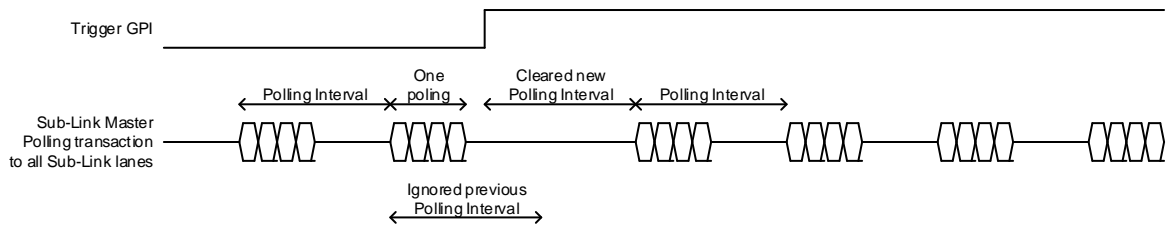

Polling Timer Mask

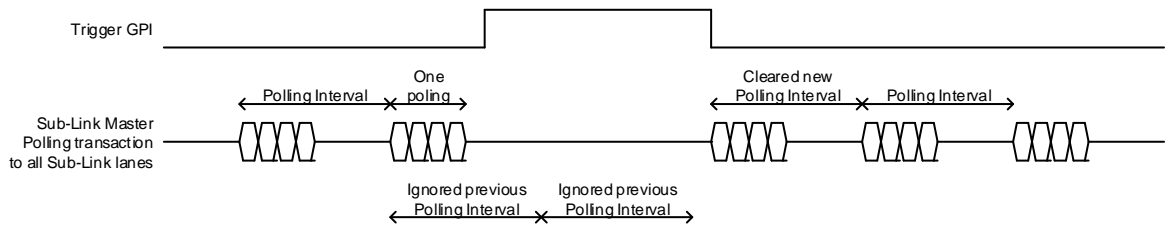

Figure 10. Sub-Link transaction time accuracy control

6.4. GPIO setting

Setting of GPIO can be configurable by 2-wire access to internal register.

Table 15. GPIO setting 1/2

Adr	bit	Register Name	width	R/W	init	Description
0x10 01	[7:4]	R_GPIO7_MODE	4	R/W	4'h0	GPIO7 I/O Mode 0:Disable 1:Programmable GPO (Output Low) 2:Programmable GPO (Output High) 3:Through GPI Mode 4:Through GPO Mode 5:Second 2WIRE Mode (SCL) 6:Second 2WIRE Mode (SDA) 7-F:Reserved
0x10 01	[3:0]	R_GPIO6_MODE	4	R/W	4'h0	GPIO6 I/O Mode 0:Disable 1:Programmable GPO (Output Low) 2:Programmable GPO (Output High) 3:Through GPI Mode 4:Through GPO Mode 5:Second 2WIRE Mode (SCL) 6:Second 2WIRE Mode (SDA) 7-F:Reserved
0x10 02	[7:4]	R_GPIO5_MODE	4	R/W	4'h0	GPIO5 I/O Mode 0:Disable 1:Programmable GPO (Output Low) 2:Programmable GPO (Output High) 3:Through GPI Mode 4:Through GPO Mode 5:Second 2WIRE Mode (SCL) 6:Second 2WIRE Mode (SDA) 7-F:Reserved
0x10 02	[3:0]	R_GPIO4_MODE	4	R/W	4'h0	GPIO4 I/O Mode 0:Disable 1:Programmable GPO (Output Low) 2:Programmable GPO (Output High) 3:Through GPI Mode 4:Through GPO Mode 5:Second 2WIRE Mode (SCL) 6:Second 2WIRE Mode (SDA) 7-F:Reserved
0x10 03	[7:4]	R_GPIO3_MODE	4	R/W	4'h0	GPIO3 I/O Mode 0:Disable 1:Programmable GPO (Output Low) 2:Programmable GPO (Output High) 3:Through GPI Mode 4:Through GPO Mode 5:Second 2WIRE Mode (SCL) 6:Second 2WIRE Mode (SDA) 7-F:Reserved
0x10 03	[3:0]	R_GPIO2_MODE	4	R/W	4'h0	GPIO2 I/O Mode 0:Disable 1:Programmable GPO (Output Low) 2:Programmable GPO (Output High) 3:Through GPI Mode 4:Through GPO Mode 5:Second 2WIRE Mode (SCL) 6:Second 2WIRE Mode (SDA) 7-F:Reserved

Table 16. GPIO setting 2/2

Adr	bit	Register Name	width	R/W	init	Description
0x10 04	[7:4]	R_GPIO1_MODE	4	R/W	4'h0	GPIO1 I/O Mode 0:Disable 1:Programable GPO (Output Low) 2:Programable GPO (Output High) 3:Through GPI Mode 4:Through GPO Mode 5:Second 2WIRE Mode (SCL) 6:Second 2WIRE Mode (SDA) 7-F:Reserved
0x10 04	[3:0]	R_GPIO0_MODE	4	R/W	4'h0	GPIO0 I/O Mode 0:Disable 1:Programable GPO (Output Low) 2:Programable GPO (Output High) 3:Through GPI Mode 4:Through GPO Mode 5:Second 2WIRE Mode (SCL) 6:Second 2WIRE Mode (SDA) 7-F:Reserved

6.4.1. Register GPIO

GPIO output control are available with register.

6.4.2. Through GPIO

Local GPIO input is continuously reflected to remote GPIO output via Sub-Link polling. Bridging data are sampled every Sub-Link polling, whose basic interval is controlled by register R_SLINK_POL_TIM_UP/DN. Remote 2-wire access may become long transaction and could lengthen Through GPIO polling reflection interval.

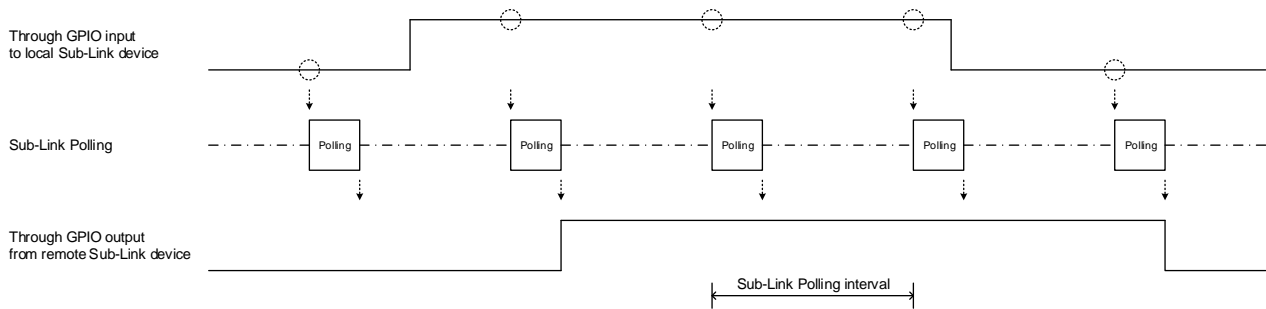

Figure 11. Through GPIO bridge sampling

As default setting with THCV231 as Sub-Link Slave communication (THCV242 as Sub-Link Master), GPIO1 Sub-Link Polling bridges input to THCV231-GPIO4 Through Mode and GPIO0 Sub-Link Polling bridges input to THCV231-GPIO3 Through Mode respectively.

As default setting with THCV241 as Sub-Link Slave communication (THCV242 as Sub-Link Master), GPIO0/1 are dedicated to GPI to Sub-Link Lane0. GPIO2/3 are dedicated to GPI to Sub-Link Lane1. GPIO2/3 are also dedicated to GPO from selected Sub-Link Lane.

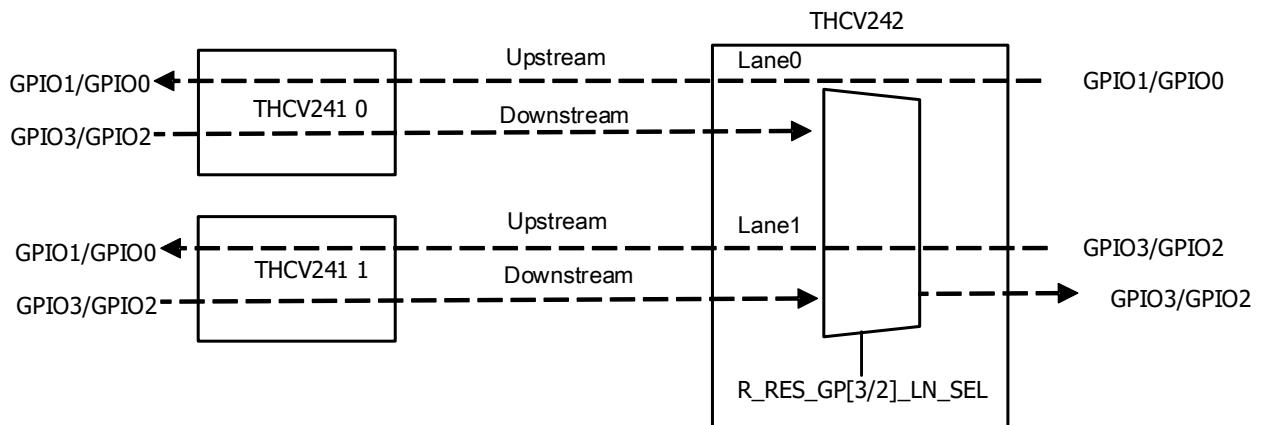

Figure 12. Through GPIO via Sub-Link transaction assignment with THCV241

Remote UART bridge is supported with Sub-Link Through GPIO input/output. Remote UART Tx and Rx bridge baud rate is supposed to be designed against Sub-Link Polling interval to accommodate deterministic jitter caused by intermittent Sub-Link communication timing.



6.4.3. GPIO as secondary 2-wire port

GPIO port can be secondary 2-wire port, which can accommodate dual 2-wire access from two processors.

6.5. MIPI

6.5.1. Deserializer and CSI-2 Formatter

6.5.1.1. PLL setting

PLL setting is required. PLL setting set R_PLL_SETTING[47:0] is related with Main-Link data-rate.

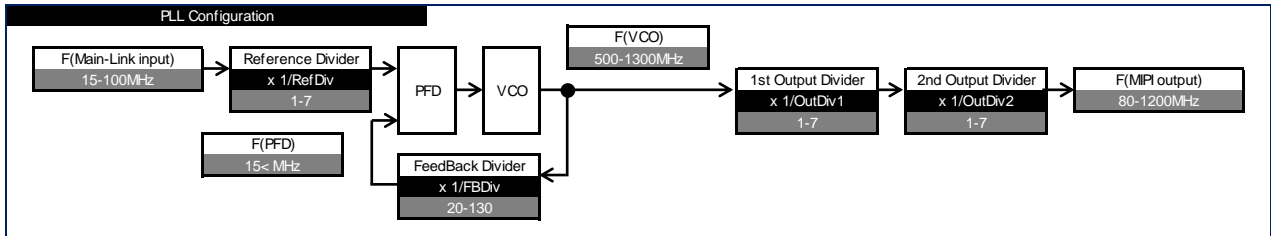

Figure 1 Reference clock supply basic method

PLL_SETTING[47:0] must be selected proper to meet below constraints.

Table 1 PLL constraints

symbol	discription	min	typ	max	unit
F(IN)	PLL input pixel clock frequency	10	-	133.3	MHz
RefDiv	Reference Divider value	1	-	7	-
FBDiv	FeedBack Divider value	20	-	130	-
OutDiv1	1st Output Divider value (OutDiv1 must be >= OutDiv2)	1	-	7	-
OutDiv2	2nd Output Divider value (OutDiv1 must be >= OutDiv2)	1	-	7	-
F(PFD)	PFD frequency	10	-		MHz
F(VCO)	VCO frequency	500	-	1300	MHz
F(OUT)	PLL output pixel clock frequency	80	-	1200	MHz

Pixel clock frequency made by PLL is calculated as below.

$$[\text{PCLK.input}] = \text{Pixel clock recovered on V-by-One® HS per lane} = [\text{F(Main-Link input)}] = \text{F(IN)}$$

$$[\text{F(Main-Link input)}] = \text{Main-Link data-rate per lane} / (\text{Byte mode} \times 8 \times 10/8)$$

$$\begin{aligned} \text{MIPI data-rate per lane (Mbps)} &= [\text{F(MIPI output)}] \text{ (MHz)} \\ &= \text{MIPI High Speed mode data-rate per lane} \end{aligned}$$

$$\text{F(VCO)} = \frac{[\text{F(Main-Link input)}] \times [\text{FBDiv}]}{[\text{RefDiv}]}$$

$$[\text{PCLK.output}] = [\text{F(MIPI output)}] = \frac{[\text{F(Main-Link input)}] \times [\text{FBDiv}]}{[\text{RefDiv}] \times [\text{OutDiv1}] \times [\text{OutDiv2}]} = \text{F(OUT)}$$

$$\frac{[\text{F(MIPI output)}]}{[\text{F(Main-Link input)}]} = \frac{[\text{FBDiv}]}{[\text{RefDiv}] \times [\text{OutDiv1}] \times [\text{OutDiv2}]}$$

$$\text{MIPI High Speed mode DDR output clock per lane} = [\text{F(MIPI output)}] / 2 \text{ (MHz)}$$

Table 2 PLL setting

Adr	bit	Register Name	width	R/W	init	Description
0x10 21	[7:0]	R_PLL_SETTING[47:40]	8	R/W	8'h0	PLL setting value, Feedback Divider value (integer part)
0x10 22	[7:3]	R_PLL_SETTING[39:35]	5	-	5'h0	PLL setting value (Must be set 0)
0x10 22	[2:0]	R_PLL_SETTING[34:32]	3	R/W	3'h0	PLL setting value, Reference Divider value
0x10 23	[7]	R_PLL_SETTING[31]	1	-	1'h0	PLL setting value (Must be set 0)
0x10 23	[6:4]	R_PLL_SETTING[30:28]	3	R/W	3'h0	PLL setting value, OutDiv1 (OutDiv1 must be >= OutDiv2)
0x10 23	[3]	R_PLL_SETTING[27]	1	-	1'h0	PLL setting value (Must be set 0)
0x10 23	[2:0]	R_PLL_SETTING[26:24]	3	R/W	3'h0	PLL setting value, OutDiv2 (OutDiv1 must be >= OutDiv2)
0x10 24	[7:0]	R_PLL_SETTING[23:16]	8	R/W	8'h0	PLL setting value, Feedback Divider value (decimal part MSB)
0x10 25	[7:0]	R_PLL_SETTING[15:8]	8	R/W	8'h0	PLL setting value, Feedback Divider value (decimal part)
0x10 26	[7:0]	R_PLL_SETTING[7:0]	8	R/W	8'h0	PLL setting value, Feedback Divider value (decimal part LSB)

PLL setting must fulfill below frequency ratio rule.

Table 3 PLL frequency ratio rule

Format	$\frac{[F(\text{MPI output})]}{[F(\text{Main-Link input})]}$ frequency ratio
MPRF	$1 * [\text{Main-Link input lane}]^4 * 8 / [\text{MPI output lane}]$
RGB888	$3/4 * [\text{Main-Link input lane}]^4 * 8 / [\text{MPI output lane}]$
YUV422 Normal	$2/4 * [\text{Main-Link input lane}]^4 * 8 / [\text{MPI output lane}]$
YUV422 Demux	$1 * [\text{Main-Link input lane}]^4 * 8 / [\text{MPI output lane}]$
RAW8 Normal	$2/4 * [\text{Main-Link input lane}]^4 * 8 / [\text{MPI output lane}]$
RAW8 Demux	$1 * [\text{Main-Link input lane}]^4 * 8 / [\text{MPI output lane}]$
RAW10 Normal	$10/32 * [\text{Main-Link input lane}]^4 * 8 / [\text{MPI output lane}]$
RAW10 Demux	$20/32 * [\text{Main-Link input lane}]^4 * 8 / [\text{MPI output lane}]$
RAW12 Normal	$12/32 * [\text{Main-Link input lane}]^4 * 8 / [\text{MPI output lane}]$
RAW12 Demux	$24/32 * [\text{Main-Link input lane}]^4 * 8 / [\text{MPI output lane}]$

Below Table is Look Up Table example for typical cases.

Table 4 PLL setting Look Up Table example

Index	condition	Main-Link input	MPI output	Distribution	F(MLINK in)	F(VCO)	F(MPI out)	PLL[47:40]	PLL[39:32]	PLL[31:24]	PLL[23:16]	PLL[15:8]	PLL[7:0]
1	720p30fps RAW	742.5Mbps 1lane MPRF	594Mbps x1lane	off	18.5625	1188	594	0x40	0x01	0x21	0x00	0x00	0x00
3	720p30fps YUV422	750Mbps 1lane MPRF	600Mbps x1lane	off	18.75	1200	600	0x40	0x01	0x21	0x00	0x00	0x00
4	720p60fps RAW	1.114Gbps 1lane MPRF	445.5Mbps x2lane	off	27.84375	891	445.5	0x20	0x01	0x21	0x00	0x00	0x00
5	1080p30fps RAW	1.114Gbps 1lane MPRF	445.5Mbps x2lane	off	27.84375	891	445.5	0x20	0x01	0x21	0x00	0x00	0x00
6	720p60fps YUV422	1.485Gbps 1lane MPRF	594Mbps x2lane	off	37.125	1188	594	0x20	0x01	0x21	0x00	0x00	0x00
7	1080p30fps YUV422	1.485Gbps 1lane MPRF	594Mbps x2lane	off	37.125	1188	594	0x20	0x01	0x21	0x00	0x00	0x00
8	720p60fps YUV422	1.485Gbps 1lane MPRF	594Mbps x2lane x2	on	37.125	1188	594	0x20	0x01	0x21	0x00	0x00	0x00
9	720p120fps RAW	2.2275Gbps 1lane MPRF	891Mbps x2lane	off	55.6875	891	891	0x20	0x02	0x11	0x00	0x00	0x00
10	1080p60fps RAW	2.2275Gbps 1lane MPRF	891Mbps x2lane	off	55.6875	891	891	0x20	0x02	0x11	0x00	0x00	0x00
11	720p120fps YUV422	2.97Gbps 1lane MPRF	594Mbps x4lane	off	74.25	1188	594	0x20	0x02	0x21	0x00	0x00	0x00
12	1080p60fps YUV422	2.97Gbps 1lane MPRF	594Mbps x4lane	off	74.25	1188	594	0x20	0x02	0x21	0x00	0x00	0x00
13	1080p120fps RAW	2.2275Gbps 2lane MPRF	891Mbps x4lane	off	55.6875	891	891	0x20	0x02	0x11	0x00	0x00	0x00
15	720p30fps RAW	990Mbps 1lane RAW12 Demux	594Mbps x1lane	off	24.75	594	594	0x18	0x01	0x11	0x00	0x00	0x00
17	720p30fps YUV422	1.6Gbps 1lane YUV422 Normal	640Mbps x1lane	off	40	640	640	0x20	0x02	0x11	0x00	0x00	0x00
18	720p60fps RAW	1.485Gbps 1lane RAW12 Demux	445.5Mbps x2lane	off	37.125	891	445.5	0x30	0x02	0x21	0x00	0x00	0x00
19	1080p30fps RAW	1.485Gbps 1lane RAW12 Demux	445.5Mbps x2lane	off	37.125	891	445.5	0x30	0x02	0x21	0x00	0x00	0x00
20	720p60fps YUV422	2.97Gbps 1lane YUV422 Normal	594Mbps x2lane	off	74.25	1188	594	0x20	0x02	0x21	0x00	0x00	0x00
21	1080p30fps YUV422	2.97Gbps 1lane YUV422 Normal	594Mbps x2lane	off	74.25	1188	594	0x20	0x02	0x21	0x00	0x00	0x00

6.5.1.2. Video stream switch and copy/distribution

Setting of data stream handling can be configurable by 2-wire access to internal register.

Table 17. Data stream handling setting

Address	bit	Register Name	R/W	Initial	Description
0x1501	[7:5]	-	-	3'b000	Reserved
	[4:0]	R_MODE_NO	R/W	5'b0000_0	Main-Link input data stream handling mode number 5'd0,1,2,3,8,10,11 are available. Others: reserved

Table 18. Data stream handling mode

Handling R_MODE_NO	Input Camera	Distribution	Output port	Output sw ap	Input		Output	
					Main-Link_0	Main-Link_1	MIPL_0	MIPL_1
5'd0	1	Disable	1	-	Cam A	-	Cam A	-
5'd1	1	Enable	2	-	Cam A	-	Cam A	Cam A
5'd2	1	Disable	1	-	-	Cam B	Cam B	-
5'd3	1	Enable	2	-	-	Cam B	Cam B	Cam B
5'd8	1(2port)	Disable	1	-	Cam A	Cam A	Cam A	-
5'd10	2	-	2	Disable	Cam A	Cam B	Cam A	Cam B
5'd11	2	-	2	Enable	Cam A	Cam B	Cam B	Cam A

6.5.2. Header/Packet/Sync Pre-processing

Setting of Header, Packet and Sync pre-processing can be configurable by 2-wire access to internal register. Settings of Header, Packet and Sync pre-processing exist for each Main-Link input lanes respectively.

Table 19. Header/Packet/Sync pre-processing setting for Main-Link Lane0 example

Address	bit	Register Name	R/W	Initial	Description
0x1100	[7:1]	-	-	7'h00	Reserved
	[0]	R_VX1_PH_EN0	R/W	1'b0	Main-Link Lane0 Input MIPI Packet Header intake 1'b0: Packet Header from Main-Link Lane0 not used 1'b1: Packet Header from Main-Link Lane0 input
0x1101	[7:1]	-	-	7'h00	Reserved
	[0]	R_VX1_CRC_EN0	R/W	1'b0	Main-Link Lane0 Input CRC intake 1'b0: CRC from Main-Link Lane0 not used 1'b1: CRC from Main-Link Lane0 input
0x1102	[7:1]	-	-	7'h00	Reserved
	[0]	R_VX1_SP_EN0	R/W	1'b0	Main-Link Lane0 Input MIPI Short Packet intake 1'b0: Short Packet from Main-Link Lane0 not used 1'b1: Short Packet from Main-Link Lane0 input
0x1103	[7:1]	-	-	7'h00	Reserved
	[0]	R_VX1_VVALID_MODE0	R/W	1'b0	Main-Link Lane0 to MIPI VVALID generation mode 1'b0: mode1 (available with THCV241) 1'b1: mode2 (FS/FE generation from VSYNC)
0x1104	[7:1]	-	-	7'h00	Reserved
	[0]	R_VX1_VSYNC_POL0	R/W	1'b0	Main-Link Lane0 VSYNC intake polarity 1'b0: Low active / VSYNC=Low pulse 1'b1: High active / VSYNC=High pulse
0x1105	[7:0]	R_VX1_WC_LOW0	R/W	8'h00	Main-Link Lane0 to MIPI Word Count (LSB 8bit) manual setting (Only active when R_VX1_PH_EN=0)
0x1106	[7:0]	R_VX1_WC_UP0	R/W	8'h00	Main-Link Lane0 to MIPI Word Count (MSB 8bit) manual setting (Only active when R_VX1_PH_EN=0)
0x1107	[7:0]	R_VX1_DATAID0	R/W	8'h00	Main-Link Lane0 to MIPI Data ID manual setting (Only active when R_VX1_PH_EN=0)

6.5.3. MIPI output setting

Setting of MIPI output can be configurable by 2-wire access to internal register.

Table 20. MIPI output setting 1/2

Address	bit	Register Name	R/W	Initial	Description
0x1600	[7:5]	-	-	3'b000	Reserved
	[4:0]	R_ANALOG	R/W	5'h00	[4] MIPI Power Down 0: Power Down 1: Normal operation [3] MIPI Soft Reset 0: Reset 1: Normal operation [2] ReservedL: Must be set 0 [1] ReservedH: Must be set 1 [0] ReservedL: Must be set 0
0x1602	[7:0]	R_TX_LANE_SELO	R/W	8'b1110_0100	MIPI Tx Lane assignment select (SWAP) [7:6]Lane3, [5:4]Lane2, [3:2]Lane1, [1:0]Lane0 2'b00:1st Byte output 2'b01:2nd Byte output 2'b10:3rd Byte output 2'b11:4th Byte output *On 2port output configuration, 3rd and 4th Byte are 2nd PORT1 *On 2port 1lane output configuration, 1st and 3rd Byte are used
0x1603	[7:1]	-	-	7'h00	Reserved
	[1:0]	R_TX_LANE_SEL1	R/W	2'b00	MIPI 2port output 2nd PORT1 select (Select 3rd Byte assigned 2nd PORT1 TX lane)
0x1605	[7]	-	-	1'b0	Reserved
	[6:0]	R_LANE_EN	R/W	7'b0101_011	[6:5] MIPI Data lane Enable [6] Data PORT1 / 0:OFF, 1:ON [5] Data PORT0 / 0:OFF, 1:ON [4:3] MIPI CLK lane Enable [4] CLK lane1 / 0:OFF, 1:ON [3] CLK lane0 / 0:OFF, 1:ON [2:0] MIPI Configuration 3'b000:1PORT1LANE 3'b001:1PORT2LANE 3'b010:Reserved 3'b011:1PORT4LANE 3'b100:2PORT1LANE 3'b101:2PORT2LANE 3'b110:Reserved 3'b111:Reserved

Table 21. MIPI output setting 2/2

Address	bit	Register Name	R/W	Initial	Description
0x1606	[7]	-	-	1'b0	Reserved
	[6:0]	R_MODE_SET	R/W	7'b100_0000	[6] ReservedH: Must be set 1 [5:4] ReservedL: Must be set 0 [3:2] HBLANK CLK OFF [3] HBLANK CLK OFF PORT1 0:OFF (HS clock off and go into LP at HBlank) 1:ON (HS clock continuously on at HBlank) [2] HBLANK CLK OFF PORT0 0:OFF (HS clock off and go into LP at HBlank) 1:ON (HS clock continuously on at HBlank) [1:0] CLK_NOT_STOP [1] CLK_NOT_STOP PORT1 0:OFF (HS clock off at VBlank) 1:ON (HS clock permanently on) [0] CLK_NOT_STOP PORT0 0:OFF (HS clock off at VBlank) 1:ON (HS clock permanently on) "7'b100_1100" is typical usage
0x1609	[7:0]	R_TX_CLK_PREPARE0	R/W	8'd4	CLK lane PrePare period setting PORT0
0x160a	[7:0]	R_TX_CLK_ZERO0	R/W	8'h1d	CLK lane ZERO period setting PORT0
0x160b	[7:0]	R_TX_CLK_TRAILO	R/W	8'h07	CLK lane TRAIL period setting PORT0
0x160c	[7:0]	R_TX_CLK_PRE0	R/W	8'h02	CLK lane PRE period setting PORT0
0x160d	[7:0]	R_TX_CLK_POST0	R/W	8'h0c	CLK lane POST period setting PORT0
0x160e	[7:0]	R_TX_THS_EXIT0	R/W	8'h0b	Data lane EXIT period setting PORT0
0x160f	[7:0]	R_TX_TLPX0	R/W	8'h05	Data lane TLPX period setting PORT0
0x1610	[7:0]	R_TX_THS_PREPARE0	R/W	8'h04	Data lane Prepare period setting PORT0
0x1611	[7:0]	R_TX_THS_ZERO0	R/W	8'h10	Data lane ZERO period setting PORT0
0x1612	[7:0]	R_TX_THS_TRAILO	R/W	8'h07	Data lane TRAIL period setting PORT0
0x1614	[7:0]	R_TX_CLK_PREPARE1	R/W	8'h04	CLK lane PrePare period setting PORT1
0x1615	[7:0]	R_TX_CLK_ZERO1	R/W	8'h1d	CLK lane ZERO period setting PORT1
0x1616	[7:0]	R_TX_CLK_TRAIL1	R/W	8'h07	CLK lane TRAIL period setting PORT1
0x1617	[7:0]	R_TX_CLK_PRE1	R/W	8'h02	CLK lane PRE period setting PORT1
0x1618	[7:0]	R_TX_CLK_POST1	R/W	8'h0c	CLK lane POST period setting PORT1
0x1619	[7:0]	R_TX_THS_EXIT1	R/W	8'h0b	Data lane EXIT period setting PORT1
0x161a	[7:0]	R_TX_TLPX1	R/W	8'h05	Data lane TLPX period setting PORT1
0x161b	[7:0]	R_TX_THS_PREPARE1	R/W	8'h04	Data lane Prepare period setting PORT1
0x161c	[7:0]	R_TX_THS_ZERO1	R/W	8'h10	Data lane ZERO period setting PORT1
0x161d	[7:0]	R_TX_THS_TRAIL1	R/W	8'h07	Data lane TRAIL period setting PORT1
0x161f	[7:4]	-	-	2'b00	Reserved
	[3:0]	R_REQ_SEL	R/W	4'h0	MIPI Tx Lane PORT assignment [3]Lane3, [2]Lane2, [1]Lane1, [0]Lane0 0:PORT0 1:PORT1

MTX0P/N and MTX2P/N can be assigned to be MIPI 2nd port (port1).

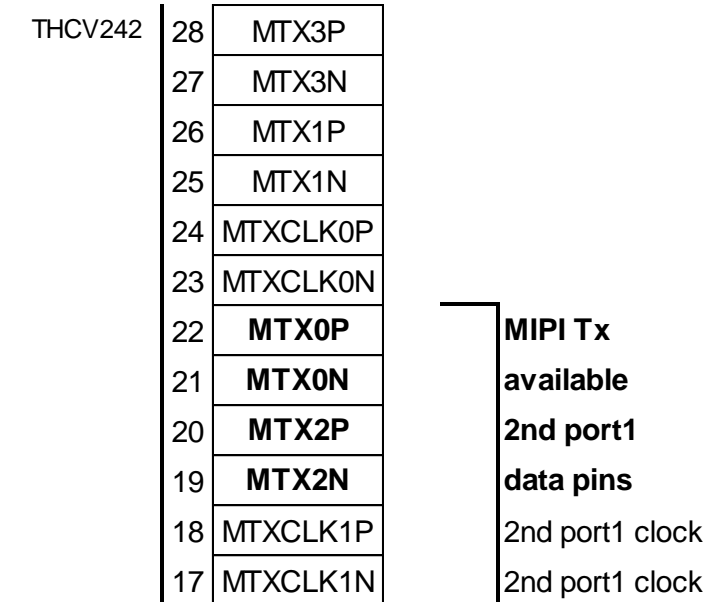

Figure 13. MIPI 2nd port available pins

Setting of MIPI 2port output examples are shown below.

Table 22. MIPI 2port output setting example

R_TX_LANE_SEL0				R_TX_LANE_SEL1				R_LANE_EN			R_REQ_SEL				MIPI Physical pin order output assignment					
lane3	lane2	lane1	lane0	port1 select				port enable	clk enable	config	lane3	lane2	lane1	lane0	lane3	lane1	lane0	lane2	lane0	lane2
[7:6]	[5:4]	[3:2]	[1:0]	[1:0]				[6:5]	[4:3]	[2:0]	[3]	[2]	[1]	[0]	lane3	lane1	lane0	lane2	lane0	lane2
01	11	00	10	00	11	11	101	0	1	0	1	0	1	MTX3PN	MTX1PN	MTXCLK0PN	MTX0PN	lane2	lane0	
01	11	00	10	00	11	11	101	0	1	0	1	0	1	port0 2nd Byte	port0 1st Byte	port0 clock	port1 1st Byte	port1 2nd Byte	port1 clock	
00	11	01	10	00	11	11	101	0	1	0	1	0	1	port0 1st Byte	port0 2nd Byte	port0 clock	port1 1st Byte	port1 2nd Byte	port1 clock	
01	11	00	10	00	11	11	100	0	1	0	1	0	1	No output	port0 1st Byte	port0 clock	port1 1st Byte	No output	port1 clock	
01	10	00	11	10	11	11	100	0	1	0	1	0	1	No output	port0 1st Byte	port0 clock	No output	port1 1st Byte	port1 clock	
00	11	01	10	00	11	11	100	0	1	0	1	0	1	port0 1st Byte	No output	port0 clock	port1 1st Byte	No output	port1 clock	

6.5.4. MIPI CSI-2 Virtual Channel

MIPI Virtual Channel (VC) is supported. When MIPI PH(Packet Header) is intake from V-by-One® HS input, MIPI Virtual Channel information in PH is also bridged from V-by-One® HS at the same time. Virtual Channel information can be intake from Main-Link input and properly applied on MIPI Packet Header by selectable register setting.

6.5.5. Multiple camera synchronization Frame Vsync supply

Frame VSYNC can be supplied from THCV242 to Sub-Link Slave GPO.

EXTSYNC input or internally generated VSYNC become supply source. Settings are configurable by 2-wire access to internal register. When internal VSYNC is selected, generated VSYNC is not only sent to remote Sub-Link Slave but also output from EXTSYNC pin.

Internal VSYNC uses two clock source, internal oscillator clock and video pixel clock from Main-Link input. At the beginning of internal VSYNC generation operation, oscillator clock is used to supply VSYNC. After Main-Link video source is received stable, internal VSYNC generation source is switched to video pixel clock from selected Main-Link input. When Main-Link video pixel clock input is lost, internal VSYNC generator again uses internal oscillator clock until Main-Link video pixel clock input is regained.

Table 23. Multiple camera synchronization Frame Vsync supply setting 1/2

Adr	bit	Register Name	width	R/W	init	Description
0x10 07	[7:4]	reserved	4	-	-	-
0x10 07	[3:0]	R_EXTSYNC_MODE	4	R/W	4'h0	EXTSYNC I/O Mode 0:Disable 1:Normal Mode (Controlled by Sub-Link Register) 2-F: Reserved

Table 24. Multiple camera synchronization Frame Vsync supply setting 2/2

Addr(h)	bit	Register Name	width	R/W	Description	Default
0x0020	[7:5]	reserved	3	-	-	-
	[4]	R_VS_PHASE_EN	1	RW	Internal VSYNC supply Phase Shift Enable (R_VS_MODE=2'd2) 0:Disable 1:Enable, Sub-Link phase of each lanes are shifted as below lane1 offset from lane0: R_VS_PHASE_WIDTH	1'b0
	[3:2]	reserved	2	-	-	-
	[1:0]	R_VS_MODE	2	RW	multiple camera synchronization Frame VSYNC supply mode setting 0: Disable 1: External VSYNC from EXTSYNC to remote camera supply 2: Internal VSYNC to remote camera supply and EXTSYNC pin output supply 3: Disable	2'd0
0x0021	[7:5]	reserved	3	-	-	-
	[4]	ReservedL	1	RW	Must be set 0	1'b0
	[3:1]	reserved	3	-	-	-
	[0]	R_VS_POL	1	RW	Internal VSYNC supply polarity (R_VS_MODE=2'd2) 0: Active Low negative polarity at Vertical blanking pulse 1: Active High positive polarity at Vertical blanking pulse	1'b0
0x0022	[7]	reserved	1	-	-	-
	[6:4]	R_VS_GPI_SEL	3	RW	Frame VSYNC supply mode Sub-Link GPI assignment bit on applied Sub-Link port 0:GPI0, 1:GPI1, 2:GPI2, 3:GPI3, 4:GPI4, 5:GPI5, 6:GPI6, 7:GPI7 *only GPI0 or GPI1 are available for 2-wire Set&Trigger mode1 and 2-wire Pass Through mode1	3'd0
	[3:2]	ReservedL	2	RW	Must be set 0	2'd0
	[1:0]	R_VS_LANE_SEL	2	RW	Frame VSYNC supply target Sub-Link port [0]:Sub-Link port0; 0:no supply, 1:Frame VSYNC supply [1]:Sub-Link port1; 0:no supply, 1:Frame VSYNC supply	2'd0
0x0023	[7:4]	reserved	4	-	-	-
	[3:0]	R_VSOOSC_LINE_UP	4	RW	Internal VSYNC clock number / line by oscillator setting	4'd0
0x0024	[7:0]	R_VSOOSC_LINE_DN	8	RW	Internal VSYNC clock number / line by oscillator = (256xR_VSOOSC_LINE_UP<3:0> +R_VSOOSC_LINE_DN<7:0>+1)xOSC *Clock / line is 1 when R_VSOOSC_LINE_UP=0 and R_VSOOSC_LINE_DN=0	8'd15
0x0025	[7:0]	R_VSOOSC_WIDTH	8	RW	Internal VSYNC pulse width line number by oscillator setting Line Number = R_VSOOSC_WIDTH + 1 (e.g. 0x0 for 1line)	8'd4
0x0026	[7:4]	reserved	4	-	-	-
	[3:0]	R_VSOOSC_TIM_UP	4	RW	Internal VSYNC pulse interval line number by oscillator setting	4'd0
0x0027	[7:0]	R_VSOOSC_TIM_DN	8	RW	Internal VSYNC pulse interval line number by oscillator = (256xR_VSOOSC_TIM_UP<3:0> +R_VSOOSC_TIM_DN<7:0>+1)xOSC *Interval line is 2 when R_VSOOSC_TIM_UP=0 and R_VSOOSC_TIM_DN=0	8'd15
0x0028	[7:2]	reserved	6	-	-	-
	[1:0]	R_VS_PCLK_SEL	2	RW	Internal VSYNC generation base pixel clock domain select 0: CLK_I from Main-Link Lane0 1: CLK_I from Main-Link Lane1 2: Reserved 3: Reserved	2'd0
0x0029	[7:4]	reserved	4	-	-	-
	[3:0]	R_VSP_LINE_UP	4	RW	Internal VSYNC clock number / line by base pixel clock setting	4'd0
0x002A	[7:0]	R_VSP_LINE_DN	8	RW	Internal VSYNC clock number / line by base pixel clock = (256xR_VSP_LINE_UP<3:0> +R_VSP_LINE_DN<7:0>+1)xCLK_I *Clock / line is 1 when R_VSP_LINE_UP=0 and R_VSP_LINE_DN=0 *For setting or reset of this register, R_VS_MODE is supposed to be Disable	8'd15
0x002B	[7:0]	R_VSP_WIDTH	8	RW	Internal VSYNC pulse width line number by base pixel clock setting Line Number = R_VSP_WIDTH + 1 (e.g. 0x0 for 1line) *For setting or reset of this register, R_VS_MODE is supposed to be Disable	8'd4
0x002C	[7:4]	reserved	4	-	-	-
	[3:0]	R_VSP_TIM_UP	4	RW	Internal VSYNC pulse interval line number setting	4'd0
0x002D	[7:0]	R_VSP_TIM_DN	8	RW	Internal VSYNC pulse interval line number = (256xR_VSP_TIM_UP<3:0> +R_VSP_TIM_DN<7:0>+1) Internal VSYNC pulse interval frame period by base pixel clock = (256xR_VSP_TIM_UP<3:0> +R_VSP_TIM_DN<7:0>+1) x (256xR_VSP_LINE_UP<3:0> +R_VSP_LINE_DN<7:0>+1)xCLK_I *Interval line is 2 when R_VSP_TIM_UP=0 and R_VSP_TIM_DN=0 *For setting or reset of this register, R_VS_MODE is supposed to be Disable	8'd15
0x002E	[7:0]	R_VS_PHASE_WIDTH	8	RW	VSYNC Phase shift difference = 16xR_VS_PHASE_WIDTH<7:0>xCLK_I *Phase shift difference is 16xCLK_I as exception when R_VS_PHASE_WIDTH=0 *For setting or reset of this register, R_VS_PHASE_EN is supposed to be Disable	8'd1
0x002F	[7:0]	reserved	8	-	-	-

6.6. Status monitoring, Interrupt and Error Detection

6.6.1. Internal Error / status signal monitoring pin output

Internal error or status signal can be monitored as external ERR0/ERR1 pin output by register setting.

Table 25. Internal Error / status signal monitoring ERR0/ERR1 pin output setting

Adr	bit	Register Name	width	R/W	init	Description
0x10 05	[7:4]	R_ERR1_MODE	4	R/W	4'h0	ERRR1 I/O Mode 0:Disable 1:OpenDrain Output Mode 2:Push/Pull Output Mode 3-F:Reserved
0x10 05	[3:0]	R_ERR0_MODE	4	R/W	4'h0	ERRR0 I/O Mode 0:Disable 1:OpenDrain Output Mode 2:Push/Pull Output Mode 3-F:Reserved
0x10 0C	[7:0]	R_ERR1_SEL	8	R/W	8'h0	ERR1 Pin Signal Select
0x10 0D	[7:0]	R_ERR0_SEL	8	R/W	8'h0	ERR0 Pin Signal Select

Table 26. IC Internal selectable Error / status signal 1/3

R_ERR1/0_SEL[7:0]	Error signal	Description
0x00	0 Fixed	
0x01	1 Fixed	
0x02	Vx1_LOCKN_ALL	OR operated of all operating lanes
0x03	Vx1_HTPDN_ALL	OR operated of all operating lanes
0x04	Vx1_FBETOUT_LATCH_ALL	OR operated of all operating lanes
0x05	Vx1_FBETOUT_REAL_ALL	OR operated of all operating lanes
0x06	Vx1_PERR_ALL	OR operated of all operating lanes, protocol error
0x07	MLINK_CRCERR_ALL	OR operated of all operating lanes
0x08	Vx1_CLOCKSTP_ALL	clock stop detector of all lanes
0x09	MLINK_VDSK_OK_ALL	Vsync synchronization OK flag of all lanes
0x0A	MLINK_VDSK_NG_ALL	Vsync synchronization NG flag of all lanes
0x0B	MLINK_DSHNDLRERR_ALL	Data Stream Handler Error of all lanes
0x0C	Reserved	
0x0D	SLINK_PERR_ALL	OR operated of all operating lanes, protocol error
0x0E	SLINK_TMOUT_ALL	OR operated of all operating lanes, time out error
0x0F	SLINK_FBETOUT	OR operated of all operating lanes
0x10	Vx1_LOCKN0	lane0
0x11	Vx1_LOCKN1	lane1
0x12	Reserved	
0x13	Reserved	
0x14	Vx1_HTPDN0	lane0
0x15	Vx1_HTPDN1	lane1
0x16	Reserved	
0x17	Reserved	
0x18	Vx1_BETOUT_LATCH0	lane0
0x19	Vx1_BETOUT_LATCH1	lane1
0x1A	Reserved	
0x1B	Reserved	
0x1C	Vx1_BETOUT_REAL0	lane0
0x1D	Vx1_BETOUT_REAL1	lane1
0x1E	Reserved	
0x1F	Reserved	

Table 27. IC Internal selectable Error / status signal 2/3

R_ERR1/0_SEL[7:0]	Error signal	Description
0x20	Vx1_PERR0	lane0, protocol error
0x21	Vx1_PERR1	lane1, protocol error
0x22	Reserved	
0x23	Reserved	
0x24	MLINK_CRCERR0	lane0
0x25	MLINK_CRCERR1	lane1
0x26	Reserved	
0x27	Reserved	
0x28	MLINK_VSYNC0	lane0
0x29	MLINK_VSYNC1	lane1
0x2A	Reserved	
0x2B	Reserved	
0x2C	MLINK_HSYNC0	lane0
0x2D	MLINK_HSYNC1	lane1
0x2E	Reserved	
0x2F	Reserved	
0x30	MLINK_DE0	lane0
0x31	MLINK_DE1	lane1
0x32	Reserved	
0x33	Reserved	
0x34	MLINK_CLK0	lane0
0x35	MLINK_CLK1	lane1
0x36	Reserved	
0x37	Reserved	
0x38	MIPI_BYTECLK	
0x39	OSCCLK	
0x3A	Reserved	
0x3B	Reserved	
0x3C	Reserved	
0x3D	Reserved	
0x3E	Reserved	
0x3F	Reserved	

Table 28. IC Internal selectable Error / status signal 3/3

R_ERR1/0_SEL[7:0]	Error signal	Description
0x40	MLINK_FS0	lane0, Frame Start
0x41	MLINK_FS1	lane1, Frame Start
0x42	Reserved	
0x43	Reserved	
0x44	MLINK_FE0	lane0, Frame End
0x45	MLINK_FE1	lane1, Frame End
0x46	Reserved	
0x47	Reserved	
0x48	MLINK_VDSK_NG0	lane0, Vsync synchronization NG flag
0x49	MLINK_VDSK_NG1	lane1, Vsync synchronization NG flag
0x4A	Reserved	
0x4B	Reserved	
0x4C	TOP_CKSUM_ERR	register checksum error
0x4D	Reserved	
0x4E	Reserved	
0x4F	Reserved	
0x50	Reserved	
0x51	Reserved	
0x52	Reserved	
0x53	Reserved	
0x54	SLINK_PERR0	lane0, protocol error
0x55	SLINK_PERR1	lane1, protocol error
0x56	Reserved	
0x57	Reserved	
0x58	SLINK_TMOUT0	lane0, time out error
0x59	SLINK_TMOUT1	lane1, time out error
0x5A	Reserved	
0x5B	Reserved	

6.6.2. Internal Error / status signal monitoring register

Internal error or status signal can be monitored as register read value.

Error count register can be cleared by particular register write “1” access.

Table 29. Internal Error / status signal monitoring register 1/2

Addr(h)	bit	Register Name	width	R/W	Description	Default
0x00F1	[7:1]	reserved	7	-	-	-
	[0]	R_SLINK_FBETERR_CLR	1	W	Sub-Link FieldBET error count clear 1: Clear	-
0x00F2	[7:0]	R_SLINK_FBETERR_NUM_UP	8	R	Sub-Link FieldBET error count parameter	-
0x00F3	[7:0]	R_SLINK_FBETERR_NUM_DN	8	R	Sub-Link FieldBET error count =256×R_SLINK_FBETERR_NUM_UP<7:0> +R_SLINK_FBETERR_NUM_DN<7:0>	-

Table 30. Internal Error / status signal monitoring register 2/2

Adr	bit	Register Name	width	R/W	init	Description
0x17 4F	[7:4]	R_MLINK_CRC_ERRCLR	4	W	-	Main-Link CRC Error Counter Clear 1:Clear
	[3:0]	R_MLINK_BET_ERRCLR	4	W	-	Main-Link BET Error Counter Clear 1:Clear
0x17 50	[7:0]	MLINK0_CRC_ERRNUM[15:8]	8	R	-	Main-Link(Lane0) CRC Error Number (Upper Byte)
0x17 51	[7:0]	MLINK0_CRC_ERRNUM[7:0]	8	R	-	Main-Link(Lane0) CRC Error Number (Lower Byte)
0x17 52	[7:0]	MLINK1_CRC_ERRNUM[15:8]	8	R	-	Main-Link(Lane1) CRC Error Number (Upper Byte)
0x17 53	[7:0]	MLINK1_CRC_ERRNUM[7:0]	8	R	-	Main-Link(Lane1) CRC Error Number (Lower Byte)
0x17 58	[7:0]	MLINK0_BET_ERRNUM[15:8]	8	R	-	Main-Link(Lane0) BET Error Number (Upper Byte)
0x17 59	[7:0]	MLINK0_BET_ERRNUM[7:0]	8	R	-	Main-Link(Lane0) BET Error Number (Lower Byte)
0x17 5A	[7:0]	MLINK1_BET_ERRNUM[15:8]	8	R	-	Main-Link(Lane1) BET Error Number (Upper Byte)
0x17 5B	[7:0]	MLINK1_BET_ERRNUM[7:0]	8	R	-	Main-Link(Lane1) BET Error Number (Lower Byte)

6.6.3. Interrupt monitoring

Interrupt (INT1/0) detects occurrence of internal error or status signal and then, latch the detected state.

Interrupt factor can be cleared by particular register* write “1” access. (*They are indicated as “R_INTC_*”)

Interrupt factor can be masked to “0” fixed by particular register appropriate write access.

INT interrupt function is supposed to be cleared before start monitoring any desired status because INT status may change at power on condition and THCV242 internal boot up procedure.

Table 31. Interrupt monitoring

Register	Address	bit	Description
R_INTR_MLRX	0x1710/ 0x1718	7	Reserved
		6	Reserved
		5	MAINLINKRX protocol error for Lane1
		4	MAINLINKRX protocol error for Lane0
		3	Reserved
		2	Reserved
		1	MAINLINKRX LOCKN=L to H detection for Lane1
		0	MAINLINKRX LOCKN=L to H detection for Lane0
		R_INTR_MODE	0x1711/ 0x1719
R_INTR_DSHDLR	6	All MAINLINKRX LOCKN=H detection	
	5	Data Stream Handler Distribution error	
R_INTR_FMT	4	Data Stream Handler error	
	3	Reserved	
	2	Reserved	
	1	MAINLINKRX CRC error for Lane1	
	0	MAINLINKRX CRC error for Lane0	
R_INTR_CSI	0x1712/ 0x171A	1	
		0	MIPI CSI-2 ULPS END signal PORT0
	0x1713/ 0x171B	6	MIPI CSI-2 general error
		5	MIPI CSI-2 EOT error for CLK Lane1
		4	MIPI CSI-2 EOT error for CLK Lane0
		3	MIPI CSI-2 SOT error for Data Lane3
		2	MIPI CSI-2 SOT error for Data Lane2
		1	MIPI CSI-2 SOT error for Data Lane1
		0	MIPI CSI-2 SOT error for Data Lane0
R_INTR_BDC2Q	0x1714/ 0x171C	1	Internal Register AutoCheckSum error flag
		0	All Interrption Clear to remote Sub-Link slave complete flag
	0x1715/ 0x171D	7	Reserved
		6	Reserved
		5	Sub-Link Slave side 2-wire access complete flag for Lane1
		4	Sub-Link Slave side 2-wire access complete flag for Lane0
		3	Reserved
		2	Reserved
		1	Sub-Link Slave side interrupt detection flag for Lane1
	0	Sub-Link Slave side interrupt detection flag for Lane0	
	0x1716/ 0x171E	7	Reserved
		6	Reserved
		5	Sub-Link protocol error for Lane1
		4	Sub-Link protocol error for Lane0
		3	Reserved
2		Reserved	
1		Reserved	
0		Reserved	

As a register, interrupt detected state is “1” and cleared state is “0”. When multiple interrupt sources are activated, the OR operated result is indicated as IC external INT1/0 pin output.

As an external INT1/0 pin output, open drain output interrupt detected state is “Low” and cleared state is “Hi-Z”, while INT1/0 pin CMOS push-pull output interrupt detected state is “Low” and cleared state is “High”.

Table 32. INT1/0 pin output control

Adr	bit	Register Name	width	R/W	init	Description
0x10 06	[7:4]	R_INT1_MODE	4	R/W	4'h0	INT1 I/O Mode 0:Disable 1:OpenDrain Output Mode 2:Push/Pull Output Mode 3-F:Reserved
0x10 06	[3:0]	R_INT0_MODE	4	R/W	4'h0	INT0 I/O Mode 0:Disable 1:OpenDrain Output Mode 2:Push/Pull Output Mode 3-F:Reserved

INT1/0 interrupt function is supposed to be cleared before start monitoring any desired status because INT1/0 status may have been changed before monitoring activation.

6.6.4. Register Auto Checksum diagnosis

Register values checksum is continuously calculated as R_CKSUM_RVAL.

Table 33. Register Auto Checksum diagnosis control and monitoring

Addr(h)	bit	Register Name	width	R/W	Description	Default
0x0008	[7:1]	reserved	7	-	-	-
	[0]	R_CKSUM_EN	1	RW	Internal Register AutoChecksum Enable 0:Disable 1:Enable	1'b0
0x0009	[7:0]	R_CKSUM_TIM	8	RW	Internal Register AutoChecksum check interval =1024x64x(R_CKSUM_TIM<7:0>+1) x tOSC	8'd19
0x000A	[7:0]	R_CKSUM_VAL	8	RW	Internal Register AutoChecksum expected target value	8'd0
0x000B	[7:0]	R_CKSUM_RVAL	8	R	Internal Register AutoChecksum read value	-

6.7. Power On Sequence

Power On Sequence must be controlled appropriate.

For Power On Reset, PDN input must be low at the moment when VDDCORE (VDD12) reach operating condition voltage. As a note, PDN pin itself does not belongs to VDDCORE (VDD12) but to VDDIO1 (VDDH). PDN Power On Reset control is mandatory.

MIPI, PLL and V-by-One® HS block are reset state at power on default and require Reset Release.

V-by-One® HS Soft Reset / PLL Soft Reset => MIPI Soft Reset is proper. See below detail.

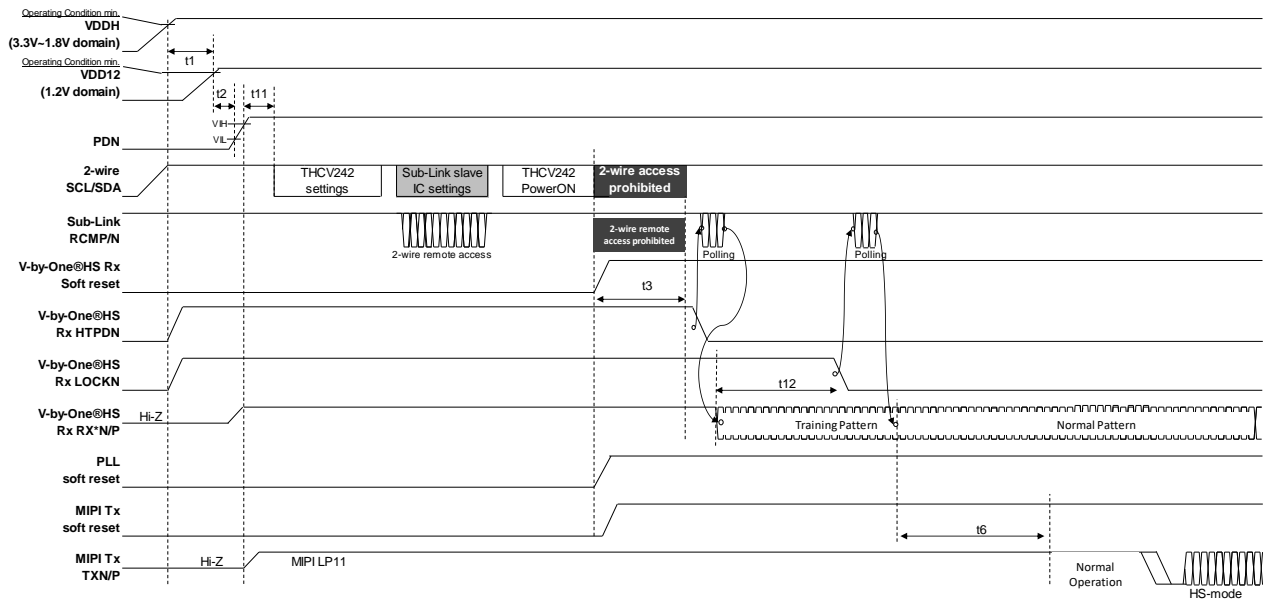

Figure 14. Power On Sequence procedure

Table 34. Power On Sequence specification

symbol	discription	min	typ	max	unit
t1	Required wait from VDD33 assert to VDD12 assert	0	-	-	us
t2	Required wait from Power On to PDN High control	1000	-	-	us
t11	Required wait from PDN High to Register Access	300	-	-	us
t3	Time of V-by-One@HS Rx soft reset High to HTPDN Low	-	-	10	us
t12	Time of Training Pattern Input to LOCKN Low	-	-	980	us
t6	Time of V-by-One@HS Normal operation input to MIPI normal operation output	-	-	50+ 1frame	us

The first MIPI output from Power On waits vertical blanking period and starts output; therefore, MIPI normal operation may be hold for maximum 1frame, which depends on used video format.

6.8. Lock / Re-Lock Sequence

Lock and re-lock sequence are as follows. V-by-One® HS automatically shifts into lock status from initial status or unlock status caused by external noise under appropriate parameter set condition.

THCV242 LOCK Sequence

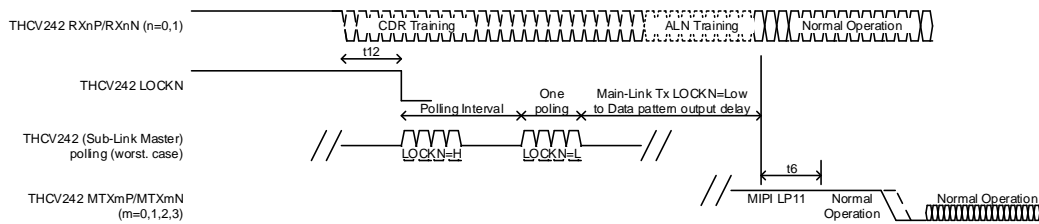

Figure 15. Lock Sequence

THCV242 Re-LOCK Sequence

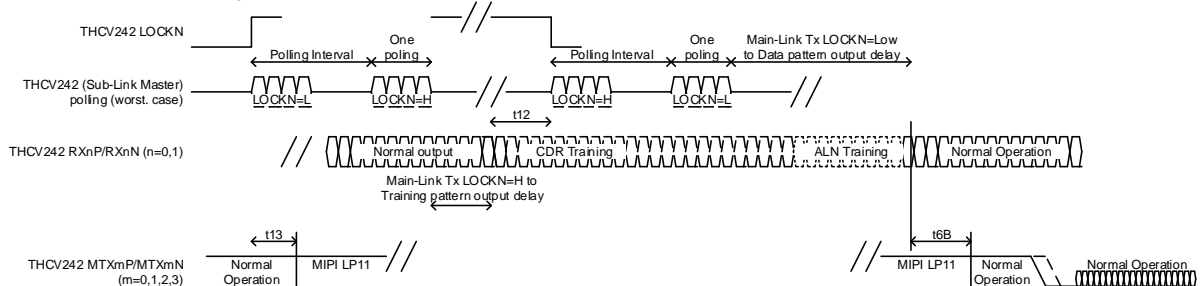

Figure 16. Re-Lock Sequence

Table 35. Lock / Re-Lock Sequence specification

symbol	discription	min	typ	max	unit
t13	Time of LOCKN=H to MIPI Stand-by LP11 output	-	-	98	us
t6B	Time of V-by-One®HS Normal operation re-input to MIPI normal operation re-output	-	-	50	us

7. Absolute Maximum Ratings

Table 36. Absolute Maximum Ratings*

Parameter	min.	typ.	max.	Unit
Supply Voltage (VDDIO1,VDDIO2)	-0.3	-	4	V
Supply Voltage (VDDCORE,VDDR,X,VDDTX,VDDPLL)	-	-	1.6	V
LVC MOS Input Voltage (1.2V domain)	-0.3	-	VDDR,X+0.3 *2	V
LVC MOS Input Voltage (VDDIO1 domain)	-0.3	-	VDDIO1+0.3 *1	V
LVC MOS Output Voltage	-0.3	-	VDDIO1+0.3 *1	V
LVC MOS Bi-directional buffer Input Voltage	-0.3	-	VDDIO1+0.3 *1	V
LVC MOS Bi-directional buffer Output Voltage	-0.3	-	VDDIO1+0.3 *1	V
LVC MOS Input Voltage (VDDIO2 domain)	-0.3	-	VDDIO2+0.3 *1	V
CML Receiver Voltage	-0.3	-	VDDR,X+0.3 *2	V
MIPI Transmitter Voltage	-0.3	-	VDDTX+0.3 *2	V
CML Bi-directional buffer Input Voltage	-0.3	-	VDDIO2+0.3 *1	V
CML Bi-directional buffer Output Voltage	-0.3	-	VDDIO2+0.3 *1	V
Output Current	-30	-	30	mA
Storage Temperature	-55	-	125	degC
Junction Temperature	-	-	125	degC
Reflow Peak Temperature/time	-	-	26	degC/sec
Maximum Power Dissipation @ +25°C	-	-	3.9	W

*1 Max. must be below 4V at the same time

*2 Max. must be below 1.6V at the same time

* “Absolute Maximum Ratings” are values of safety limit for a device beyond which a device safety cannot be guaranteed.

They do not imply that a device should be operated at these limits. The tables of “Recommended Operating Condition” specify conditions for device operation.

8. Recommended Operating Conditions

Table 37. Recommended Operating Conditions

Symbol	Parameter	Condition	Min	Typ	Max	Unit
VDDH	Supply Voltage (VDDIO1, VDDIO2)	3.3V Drive	3.0	3.3	3.6	V
		2.5V Drive	2.0	2.5	3.0	V
		1.8V Drive	1.7	1.8	2.0	V
VDD12	Supply Voltage 1.2V (VDDCORE, VDDR,X, VDDTX, VDDPLL)	-	1.1	-	1.3	V
Ta	Operating Ambient Temperature	-	-40	-	105	degC

9. Consumption Current

Table 38. Consumption Current at Power Down

Symbol	Parameter	Condition	Min	Typ	Max	Unit
ICCS33	Power Down Supply Current	PDN=0, VDDH=3.6V	-	0.1	-	mA
ICCS12		PDN=0, VDD12=1.3V	-	8	-	mA

Table 39. Consumption Current of VDDH

Symbol	Parameter	Condition	Min	Typ	Max	Unit
ICCVH_33_1	VDDIO1/2=3.3V	Sub-Link 1lane active	-	16	20	mA
ICCVH_33_2		Sub-Link 2lane active	-	32	38	mA
ICCVH_18_1	VDDIO1/2=1.8V	Sub-Link 1lane active	-	14	17	mA
ICCVH_18_2		Sub-Link 2lane active	-	27	32	mA

Table 40. Consumption Current of VDD12

Symbol	port.in#	port.out#	video format	input	output	min.	typ.	max.	Unit	
lccw12_01	1	1	quasi-1080p low fps	400Mbps x1lane	320Mbps x1lane	-	49	111	mA	
lccw12_02					80Mbps x4lane	-	49	109	mA	
lccw12_157	2		quasi-1080p high fps	4Gbps x2lane selected	800Mbps x4lane	-	177	251	mA	
lccw12_03	1	1	720p30fps RAW	742.5Mbps x1lane	594Mbps x1lane	-	60	123	mA	
lccw12_04			720p30fps YUV422	1Gbps x1lane	600Mbps x1lane	-	64	126	mA	
lccw12_05			720p60fps RAW	1.11375Gbps x1lane	445.5Mbps x2lane	-	65	128	mA	
lccw12_06			1080p30fps RAW			-	65	128	mA	
lccw12_07			720p60fps YUV422	1.485Gbps x1lane	594Mbps x2lane	-	75	139	mA	
lccw12_08			1080p30fps YUV422			-	75	139	mA	
lccw12_09		2			594Mbps x2lane x2port Dist.	-	89	158	mA	
lccw12_10		1	1	720p120fps RAW	2.2275Gbps x1lane	891Mbps x2lane	-	93	160	mA
lccw12_11				1080p60fps RAW		445.5Mbps x4lane	-	85	150	mA
lccw12_12				720p120fps YUV422		594Mbps x4lane	-	98	165	mA
lccw12_13	2		1	1080p60fps YUV422	2.97Gbps x1lane	1188Mbps x2lane	-	100	166	mA
lccw12_14						1188Mbps x2lane	-	113	184	mA
lccw12_15						1188Mbps x2lane x2port Dist.	-	135	224	mA
lccw12_153	2				1188Mbps x2lane x2port Dist.	-	135	224	mA	
lccw12_B12	1	1	1080p120fps RAW	2.2275Gbps x2lane	891Mbps x4lane	-	149	238	mA	
lccw12_B13			1080p120fps YUV422	3Gbps x2lane	1200Mbps x4lane	-	184	276	mA	
lccw12_31	2	2	720p30fps RAW	742.5Mbps x1lane x2port	594Mbps x1lane x2port	-	89	148	mA	
lccw12_33			720p30fps YUV422	750Mbps x1lane x2port	600Mbps x1lane x2port	-	90	148	mA	
lccw12_34			720p60fps RAW	1.11375Gbps x1lane x2port	445.5Mbps x2lane x2port	-	102	165	mA	
lccw12_35			1080p30fps RAW			-	102	164	mA	
lccw12_36			720p60fps YUV422	1.485Gbps x1lane x2port	594Mbps x2lane x2port	-	120	186	mA	
lccw12_37			1080p30fps YUV422			-	121	186	mA	
lccw12_38			720p120fps RAW	2.2275Gbps x1lane x2port	891Mbps x2lane x2port	-	151	219	mA	
lccw12_39			1080p60fps RAW			-	153	226	mA	
lccw12_402			720p120fps YUV422	2.97Gbps x1lane x2port	1188Mbps x2lane x2port	-	184	258	mA	
lccw12_412			1080p60fps YUV422			-	188	266	mA	

10. DC Specifications

10.1. CMOS DC Specifications

Table 41. CMOS DC Specifications

Symbol	Parameter	Condition	Min	Typ	Max	Unit
I _{IH}	LVC MOS Input Leak Current High	-	-	-	10	uA
I _{IL}	LVC MOS Input Leak Current Low	-	-	-	10	uA
V _{IH}	LVC MOS High Level Input Voltage	V _{DDIOx} =3.3V	2	-	V _{DDIO}	V
		V _{DDIOx} =2.5V	0.70*V _{DDIO}	-	V _{DDIO}	V
		V _{DDIOx} =1.8V	0.65*V _{DDIO}	-	V _{DDIO}	V
V _{IL}	LVC MOS Low Level Input Voltage	V _{DDIOx} =3.3V	0	-	0.8	V
		V _{DDIOx} =2.5V	0	-	0.30*V _{DDIO}	V
		V _{DDIOx} =1.8V	0	-	0.35*V _{DDIO}	V
V _{OH}	LVC MOS High Level Output Voltage	V _{DDIOx} =3.3V	V _{DDIO} -0.6	-	V _{DDIO}	V
		V _{DDIOx} =2.5V	V _{DDIO} -0.5	-	V _{DDIO}	V
		V _{DDIOx} =1.8V	V _{DDIO} -0.45	-	V _{DDIO}	V
V _{OL}	LVC MOS Low Level Output Voltage	-	0	-	0.45	V

10.2. CML Receiver DC Specifications

Table 42. CML Receiver DC Specifications

Symbol	Parameter	Condition	min.	typ.	max.	Unit
V _{RTH}	CML Differential Input High Threshold	-	-	-	50	mV
V _{RTL}	CML Differential Input Low Threshold	-	-50	-	-	mV
I _{RIH}	CML Input Leak Current High	PDN=L, RXP/N=1.2V	-	-	±15	uA
I _{RIL}	CML Input Leak Current Low	PDN=L, RXP/N=GND	-	-	±15	uA
I _{IRIH}	CML Input Current High	RXP/N=1.2V	-	-	1.6	mA
I _{IRIL}	CML Input Current Low	RXP/N=GND	-4.6	-	-	mA
R _{RIN}	CML Differential Input Resistance	-	80	100	120	ohm

10.3. MIPI Transmitter DC Specifications

Table 43. MIPI Transmitter DC Specifications

Symbol	Parameter	Condition	min.	typ.	max.	Unit
Γ_{IL}	Input Leak Current Low	PDN=0	-10	-	10	μ A
Γ_{IH}	Input Leak Current High	PDN=0	-10	-	10	μ A
VTCMTX	HS-mode statics Common-mode Voltage	ZID=80~125ohm	160	200	240	mV
VTOD	HS-mode Differential Voltage	ZID=100ohm	150	200	260	mV
VTOHHS	HS-mode High Level Output Voltage	ZID=100ohm	-	-	350	mV
VTOHLP	LP-mode High Level Output Voltage	-	1.1	-	1.3	V
VTOLLP	LP-mode Low Level Output Voltage	-	-0.05	-	0.05	V
ZTOLP	LP-mode Output Impedance	-	120	-	-	ohm

10.4. CML Bi-directional Buffer DC Specifications

Table 44. CML Bi-directional Buffer DC Specifications

Symbol	Parameter	Condition	Min	Typ	Max	Unit
VBTH	CML Bi-Directional Buffer Differential Input High Threshold	R_BDCZ_HYS=0	-	-	50	mV
		R_BDCZ_HYS=1	-	-	150	mV
VBTL	CML Bi-Directional Buffer Differential Input Low Threshold	R_BDCZ_HYS=0	-50	-	-	mV
		R_BDCZ_HYS=1	-150	-	-	mV
VBIC	CML Bi-Directional Buffer Input Terminated Common Voltage	R_BDCZ_TERM_** [1:0]= 2'b00 R_BDCZ_DRIVE_** DRIVE[1:0]= 2'b00	-	VDD-300	-	mV
IBIH	CML Bi-Directional Buffer Output Leak Current High	TCMP/N=VDD	-10	-	10	uA
IBIL	CML Bi-Directional Buffer Output Leak Current Low	TCMP/N=0V	-10	-	10	uA
VBOD	CML Bi-Directional Buffer Differential Output Voltage	R_BDCZ_TERM_** [1:0]=2'b10 R_BDCZ_DRIVE_** [1:0]=2'b10 Diff. 100ohm terminated	200	300	400	mV
VBOC	CML Bi-Directional Buffer Common Output Voltage	R_BDCZ_TERM_** [1:0]=2'b00 R_BDCZ_DRIVE_** [1:0]=2'b00	-	VDD-300	-	mV
IBOZ	CML Bi-Directional Buffer TRI-STATE Current	PDN1=0	-10	-	10	uA
RTERM	CML Bi-Directional Buffer Termination Registance	R_BDCZ_TERM_TX/ RX [1:0]=2'b10	-	50	-	ohm
		R_BDCZ_TERM_TX/ RX [1:0]=2'b01	-	100	-	ohm
		R_BDCZ_TERM_TX/ RX [1:0]=2'b00	-	200	-	ohm
IDRIVE	CML Bi-Directional Buffer Drive Current	R_BDCZ_DRIVE_TX/ RX [1:0]=2'b10	-	12	-	mA
		R_BDCZ_DRIVE_TX/ RX [1:0]=2'b01	-	6	-	mA
		R_BDCZ_DRIVE_TX/ RX [1:0]=2'b00	-	3	-	mA

11. AC Specifications

11.1. General AC Specifications

Table 45. General AC Specifications

Symbol	Parameter	Condition	Min	Typ	Max	Unit
tDL	Data Latency	MainLink 1Gbps Data stream handling mode1	Typ.-98	16000	Typ.+98	ns

11.2. CML Receiver AC Specifications

Table 46. CML Receiver AC Specifications

Symbol	Parameter	Condition	min.	typ.	max.	Unit
tRBIT	Unit Interval	-	250	-	2500	ps
			0.4	-	4	Gbps

11.3. MIPI Transmitter AC Specifications

Table 47. MIPI Transmitter AC Specifications

Symbol	Parameter	Conditions	min.	typ.	max.	Unit
tTBIT	Tx Unit Interval	-	0.833	-	12.5	ns
			80	-	1200	Mbps

11.4. CML B-directional Buffer AC Specifications

Table 48. CML B-directional Buffer AC Specifications

Symbol	Parameter	Condition	Min	Typ	Max	Unit
tBUI	Bi-Directional CML Buffer Unit Interval	-	128.7	137.5	172.7	ns

11.5. 2-wire serial Slave AC Specifications

Table 49. 2-wire serial Slave AC Specifications (Sub-Link Master)

Symbol	Parameter	Condition	Min	Typ	Max	Unit
tOSC	Cycle of internal oscillator clock	-	11.7	12.5	15.7	ns
fSCL	SCL clock frequency	-	-	-	1000	kHz

12. Package

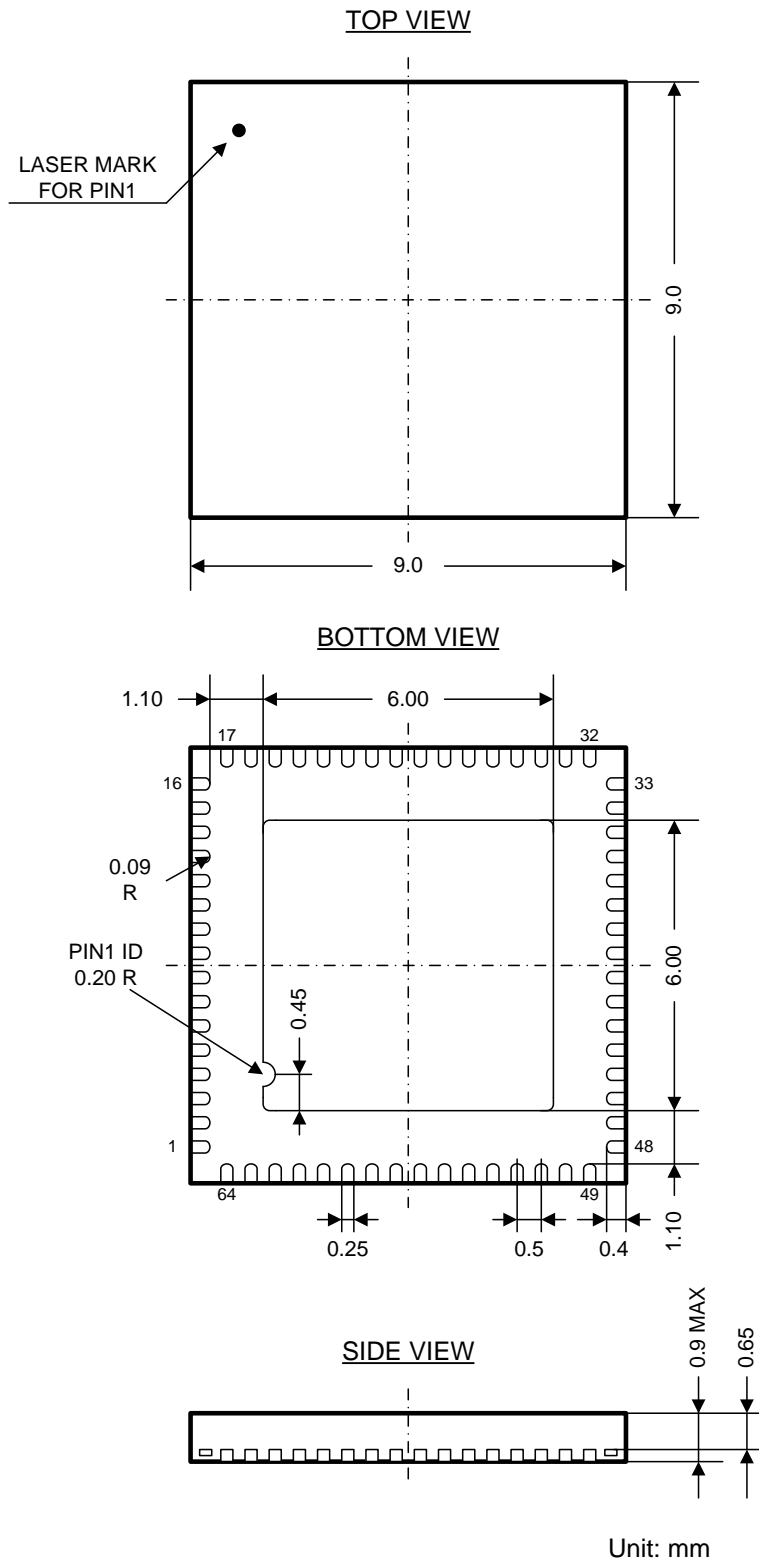



13. Notices and Requests

1. The product specifications described in this material are subject to change without prior notice.
2. The circuit diagrams described in this material are examples of the application which may not always apply to the customer's design. THine Electronics, Inc. ("THine") is not responsible for possible errors and omissions in this material. Please note even if errors or omissions should be found in this material, THine may not be able to correct them immediately.
3. This material contains THine's copyright, know-how or other proprietary. Copying or disclosing to third parties the contents of this material without THine's prior permission is prohibited.
4. Note that even if infringement of any third party's industrial ownership should occur by using this product, THine will be exempted from the responsibility unless it directly relates to the production process or functions of the product.
5. Product Application
 - 5.1 Application of this product is intended for and limited to the following applications: audio-video device, office automation device, communication device, consumer electronics, smartphone, feature phone, and amusement machine device. This product must not be used for applications that require extremely high-reliability/safety such as aerospace device, traffic device, transportation device, nuclear power control device, combustion chamber device, medical device related to critical care, or any kind of safety device.
 - 5.2 This product is not intended to be used as an automotive part, unless the product is specified as a product conforming to the demands and specifications of IATF16949 ("the Specified Product") in this data sheet. THine accepts no liability whatsoever for any product other than the Specified Product for it not conforming to the aforementioned demands and specifications.
 - 5.3 THine accepts liability for demands and specifications of the Specified Product only to the extent that the user and THine have been previously and explicitly agreed to each other.
6. Despite our utmost efforts to improve the quality and reliability of the product, faults will occur with a certain small probability, which is inevitable to a semi-conductor product. Therefore, you are encouraged to have sufficiently redundant or error preventive design applied to the use of the product so as not to have our product cause any social or public damage.
7. Please note that this product is not designed to be radiation-proof.
8. Testing and other quality control techniques are used to this product to the extent THine deems necessary to support warranty for performance of this product. Except where mandated by applicable law or deemed necessary by THine based on the user's request, testing of all functions and performance of the product is not necessarily performed.
9. Customers are asked, if required, to judge by themselves if this product falls under the category of strategic goods under the Foreign Exchange and Foreign Trade Act.
10. The product or peripheral parts may be damaged by a surge in voltage over the absolute maximum ratings or malfunction, if pins of the product are shorted by such as foreign substance. The damages may cause a smoking and ignition. Therefore, you are encouraged to implement safety measures by adding protection devices, such as fuses.

Contact:

THine@cel.com

Mouser Electronics

Authorized Distributor

Click to View Pricing, Inventory, Delivery & Lifecycle Information:

[CEL:](#)

[THCV242](#) [THCV242-B](#)

Данный компонент на территории Российской Федерации

Вы можете приобрести в компании MosChip.

Для оперативного оформления запроса Вам необходимо перейти по данной ссылке:

<http://moschip.ru/get-element>

Вы можете разместить у нас заказ для любого Вашего проекта, будь то серийное производство или разработка единичного прибора.

В нашем ассортименте представлены ведущие мировые производители активных и пассивных электронных компонентов.

Нашей специализацией является поставка электронной компонентной базы двойного назначения, продукции таких производителей как XILINX, Intel (ex.ALTERA), Vicor, Microchip, Texas Instruments, Analog Devices, Mini-Circuits, Amphenol, Glenair.

Сотрудничество с глобальными дистрибьюторами электронных компонентов, предоставляет возможность заказывать и получать с международных складов практически любой перечень компонентов в оптимальные для Вас сроки.

На всех этапах разработки и производства наши партнеры могут получить квалифицированную поддержку опытных инженеров.

Система менеджмента качества компании отвечает требованиям в соответствии с ГОСТ Р ИСО 9001, ГОСТ РВ 0015-002 и ЭС РД 009

Офис по работе с юридическими лицами:

105318, г.Москва, ул.Щербаковская д.3, офис 1107, 1118, ДЦ «Щербаковский»

Телефон: +7 495 668-12-70 (многоканальный)

Факс: +7 495 668-12-70 (доб.304)

E-mail: info@moschip.ru

Skype отдела продаж:

moschip.ru

moschip.ru_4

moschip.ru_6

moschip.ru_9