

CS65-70B SERIES

**SILICON CONTROLLED RECTIFIERS
70 AMP, 200 THRU 1200 VOLT**

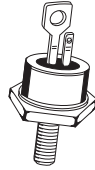

TO-65 CASE



www.centralemi.com

DESCRIPTION:

The CENTRAL SEMICONDUCTOR C65-70B series is a high power Silicon Controlled Rectifier designed for phase control applications.

MARKING: FULL PART NUMBER

MAXIMUM RATINGS: ($T_A=25^\circ\text{C}$ unless otherwise noted)

	SYMBOL	CS65						UNITS
		-70B	-70D	-70M	-70N	-70P	-70PB	
Peak Repetitive Off-State Voltage	V_{DRM}, V_{RRM}	200	400	600	800	1000	1200	V
Peak Non-Repetitive Reverse Voltage	V_{RSM}	300	500	700	900	1100	1300	V
RMS On-State Current ($T_C=102^\circ\text{C}$)	$I_T(\text{RMS})$				63			A
Average On-State Current ($T_C=102^\circ\text{C}$)	$I_T(\text{AV})$				40			A
Peak One Cycle Surge Current (60Hz)	I_{TSM}				1000			A
I^2t Value for Fusing ($t=8.3\text{ms}$)	I^2t				4100			A^2s
Peak Forward Gate Voltage	V_{FGM}				20			V
Peak Reverse Gate Voltage	V_{RGM}				10			V
Peak Gate Power	P_{GM}				10			W
Average Gate Power ($t_p=10\mu\text{s}$)	$P_{G(\text{AV})}$				1.0			W
Peak Forward Gate Current	I_{FGM}				3.0			A
Critical Rate of Rise of On-State Current	di/dt				200			$\text{A}/\mu\text{s}$
Operating Junction Temperature	T_J				-65 to +125			$^\circ\text{C}$
Storage Temperature	T_{stg}				-65 to +150			$^\circ\text{C}$
Thermal Resistance	θ_{JC}				0.35			$^\circ\text{C}/\text{W}$

ELECTRICAL CHARACTERISTICS: ($T_A=25^\circ\text{C}$ unless otherwise noted)

SYMBOL	TEST CONDITIONS	MIN	MAX	UNITS
I_{DRM}, I_{RRM}	$V_D=\text{Rated } V_{DRM}, V_{RRM}, T_C=125^\circ\text{C}$		6.0	mA
I_{GT}	$V_D=12\text{V}, R_L=33\Omega$		100	mA
I_H	$I_T=500\text{mA}$		200	mA
V_{GT}	$V_D=12\text{V}, R_L=33\Omega$		3.0	V
V_{TM}	$I_{TM}=500\text{A}$		3.0	V
dv/dt	$V_D=0.67 \times V_{DRM}, T_C=125^\circ\text{C}$	200		$\text{V}/\mu\text{s}$

R5 (17-April 2018)

CS65-70B SERIES
SILICON CONTROLLED RECTIFIERS
70 AMP, 200 THRU 1200 VOLT



TO-65 CASE - MECHANICAL OUTLINE

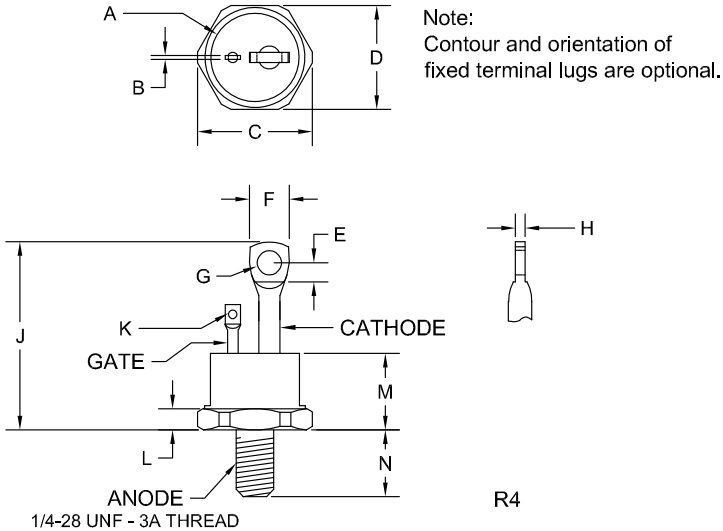

SYMBOL	INCHES		MILLIMETERS	
	MIN	MAX	MIN	MAX
A (DIA)	-	0.667	-	16.94
B	0.014	0.030	0.35	0.76
C	-	0.770	-	19.56
D	0.667	0.687	16.94	17.45
E	0.120	-	3.05	-
F	0.200	0.300	5.08	7.62
G (DIA)	0.125	0.165	3.18	4.19
H	0.026	0.085	0.65	2.15
J	1.000	1.339	25.40	34.00
K (DIA)	0.053	0.075	1.35	1.91
L	0.113	0.210	2.87	5.33
M	-	0.622	-	15.80
N	0.422	0.453	10.72	11.51

TO-65 (REV: R4)

R5 (17-April 2018)

OUTSTANDING SUPPORT AND SUPERIOR SERVICES



PRODUCT SUPPORT

Central's operations team provides the highest level of support to insure product is delivered on-time.

- Supply management (Customer portals)
- Inventory bonding
- Consolidated shipping options
- Custom bar coding for shipments
- Custom product packing

DESIGNER SUPPORT/SERVICES

Central's applications engineering team is ready to discuss your design challenges. Just ask.

- Free quick ship samples (2nd day air)
- Online technical data and parametric search
- SPICE models
- Custom electrical curves
- Environmental regulation compliance
- Customer specific screening
- Up-screening capabilities
- Special wafer diffusions
- PbSn plating options
- Package details
- Application notes
- Application and design sample kits
- Custom product and package development

REQUESTING PRODUCT PLATING

1. If requesting Tin/Lead plated devices, add the suffix " TIN/LEAD" to the part number when ordering (example: 2N2222A TIN/LEAD).
2. If requesting Lead (Pb) Free plated devices, add the suffix " PBFREE" to the part number when ordering (example: 2N2222A PBFREE).

CONTACT US

Corporate Headquarters & Customer Support Team

Central Semiconductor Corp.
145 Adams Avenue
Hauppauge, NY 11788 USA
Main Tel: (631) 435-1110
Main Fax: (631) 435-1824
Support Team Fax: (631) 435-3388
www.centrasemi.com

Worldwide Field Representatives:
www.centrasemi.com/wwreps

Worldwide Distributors:
www.centrasemi.com/wwdistributors

For the latest version of Central Semiconductor's **LIMITATIONS AND DAMAGES DISCLAIMER**, which is part of Central's Standard Terms and Conditions of sale, visit: www.centrasemi.com/terms



<http://www.centrasemi.com>

Product End of Life Notification

PDN ID:	PDN01091
Notification Date:	5/02/18
Last Buy Date:	11/02/18
Last Shipment Date	5/02/19

Summary: The CS65-70M and CEN1284 Silicon Controlled Rectifiers are discontinued and now classified as End of Life (EOL).

Although Central Semiconductor Corp. makes every effort to continue to produce devices that have been proclaimed EOL (End of Life) by other manufacturers, it is an accepted industry practice to discontinue certain devices when customer demand falls below a minimum level of sustainability. Accordingly, the following product(s) have been transitioned to End of Life status as part of Central's ongoing Product Management Process. Any replacement products are noted below. The effective date for placing last purchase orders will be six (6) months from the date of this notice and twelve (12) months from the notice date for final shipments, and minimum order quantities may apply. The last purchase and shipment dates may be extended if inventory is available.

<u>Central Part Number</u>	<u>Replacement</u>
CEN1284	N/A
CS65-70M	N/A

Central would be happy to assist you by providing additional information or technical data to help locate an alternate source if we have no replacement available. Please email your requests to engineering@centrasemi.com.

DISCLAIMER: This End of Life (EOL) notification is in accordance with JEDEC standard JESD48 - Product Discontinuance. Central Semiconductor Corp. will make every effort to offer life-time buy (LTB) opportunities and/or offer replacement devices to existing customers for discontinued devices, however, one or both may not be possible for all devices. Please contact your local Central Semiconductor sales representative for LTB opportunities/additional information.

Данный компонент на территории Российской Федерации

Вы можете приобрести в компании MosChip.

Для оперативного оформления запроса Вам необходимо перейти по данной ссылке:

<http://moschip.ru/get-element>

Вы можете разместить у нас заказ для любого Вашего проекта, будь то серийное производство или разработка единичного прибора.

В нашем ассортименте представлены ведущие мировые производители активных и пассивных электронных компонентов.

Нашей специализацией является поставка электронной компонентной базы двойного назначения, продукции таких производителей как XILINX, Intel (ex.ALTERA), Vicor, Microchip, Texas Instruments, Analog Devices, Mini-Circuits, Amphenol, Glenair.

Сотрудничество с глобальными дистрибьюторами электронных компонентов, предоставляет возможность заказывать и получать с международных складов практически любой перечень компонентов в оптимальные для Вас сроки.

На всех этапах разработки и производства наши партнеры могут получить квалифицированную поддержку опытных инженеров.

Система менеджмента качества компании отвечает требованиям в соответствии с ГОСТ Р ИСО 9001, ГОСТ РВ 0015-002 и ЭС РД 009

Офис по работе с юридическими лицами:

105318, г.Москва, ул.Щербаковская д.3, офис 1107, 1118, ДЦ «Щербаковский»

Телефон: +7 495 668-12-70 (многоканальный)

Факс: +7 495 668-12-70 (доб.304)

E-mail: info@moschip.ru

Skype отдела продаж:

moschip.ru

moschip.ru_4

moschip.ru_6

moschip.ru_9