

THIS DRAWING IS UNPUBLISHED. RELEASED FOR PUBLICATION 20  
 © COPYRIGHT 20 BY TYCO ELECTRONICS CORPORATION. ALL RIGHTS RESERVED.

LOC	DIST	REVISIONS					
GP	00	P	LTR	DESCRIPTION	DATE	DWN	APVD
		A		RELEASED PER ECO-09-016675	07AUG2009	CR	PR
		B		REVISED PER ECO-10-.013513	29JUN2010	CJV	PAR
		C		REVISED PER ECO-15-015156	14MAR2016	FL	SY

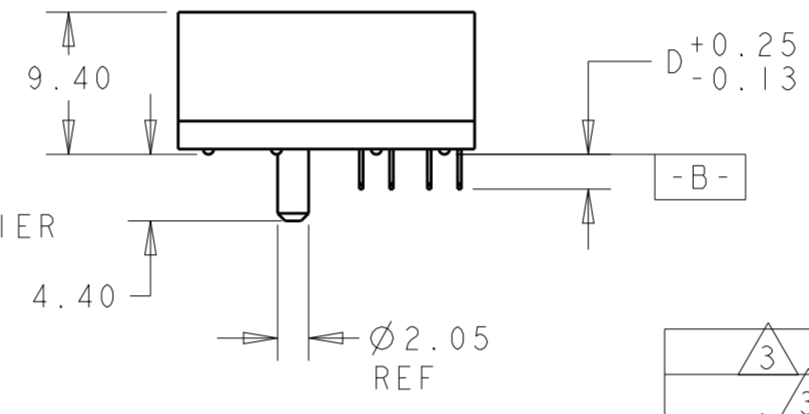

- 1 MATERIAL: HOUSING: HIGH TEMP NYLON, UL 94V-0  
 COLOR: BLACK  
 TINE PLATE: LCP, UL 94V-0,  
 COLOR: BLACK.  
 CONTACT: PHOSPHOR BRONZE
- 2 FINISH: CONTACT AREA: GOLD PLATE 0.76µm MIN THICK OVER NICKEL UNDERPLATE.  
 TINE AREA: TIN PLATE OVER NICKEL UNDERPLATE.
- 3 FINISH: CONTACT AREA: GOLD PLATE 0.38µm MIN THICK OVER NICKEL UNDERPLATE.  
 TINE AREA: TIN PLATE OVER NICKEL UNDERPLATE.
- 4 COMPANY LOGO IN APPROXIMATE AREA SHOWN.
- 5 SLOT ACCEPTS STANDARD 1.57mm±10% THICK ADD-IN CARD.

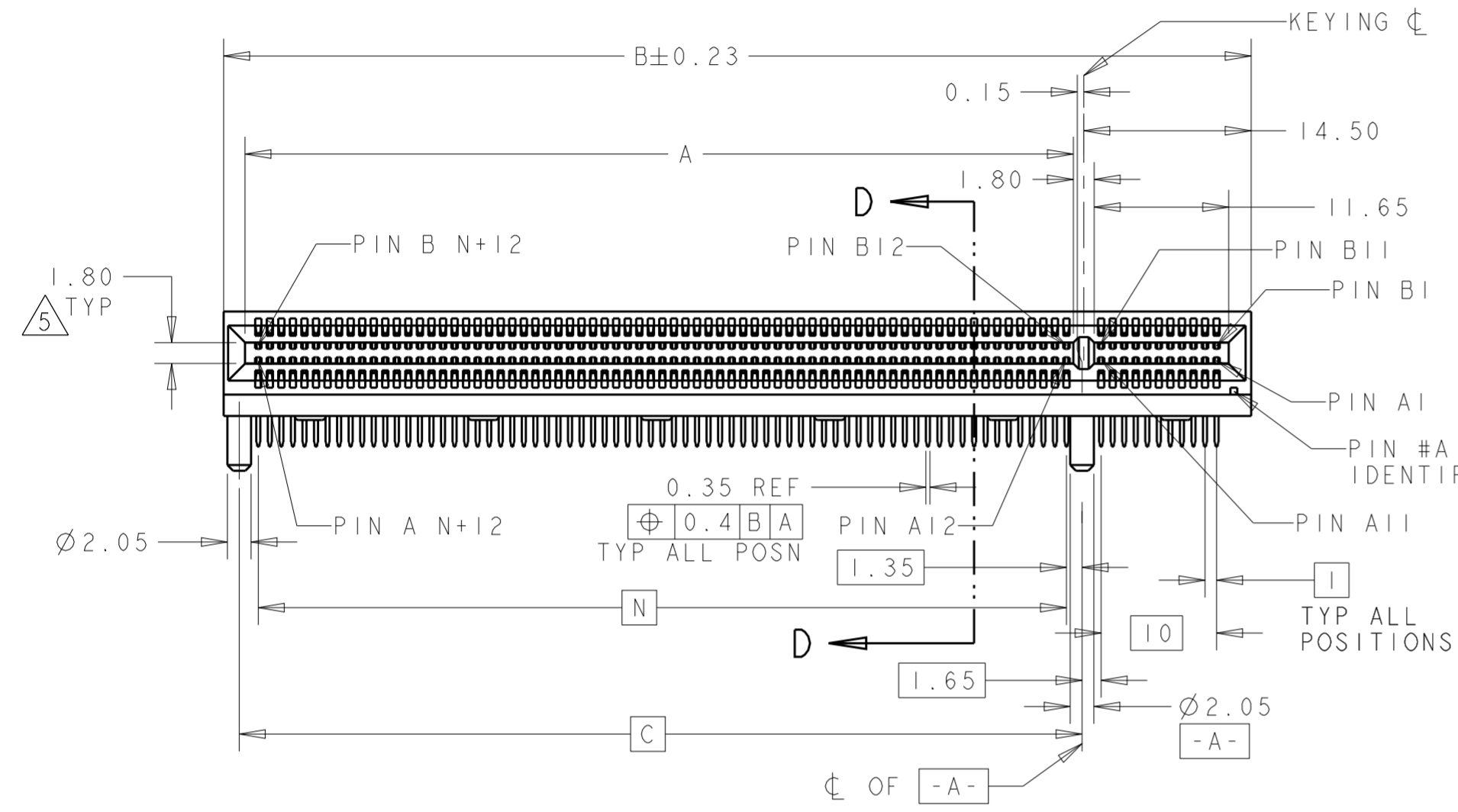
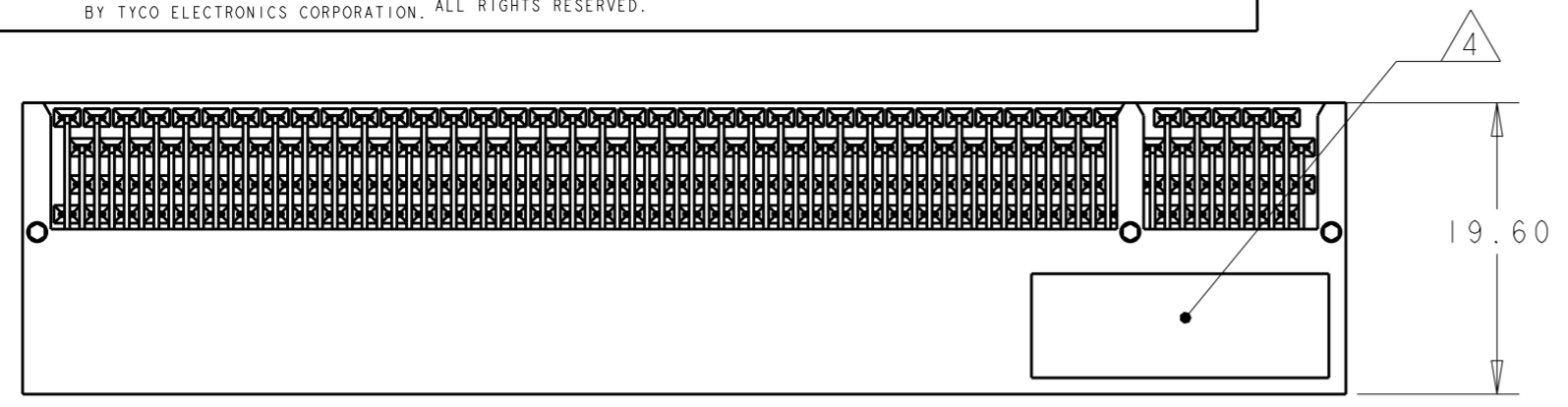
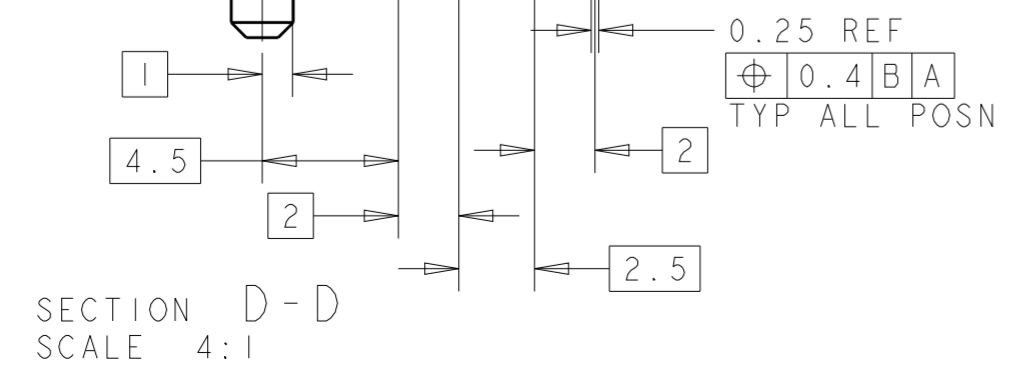
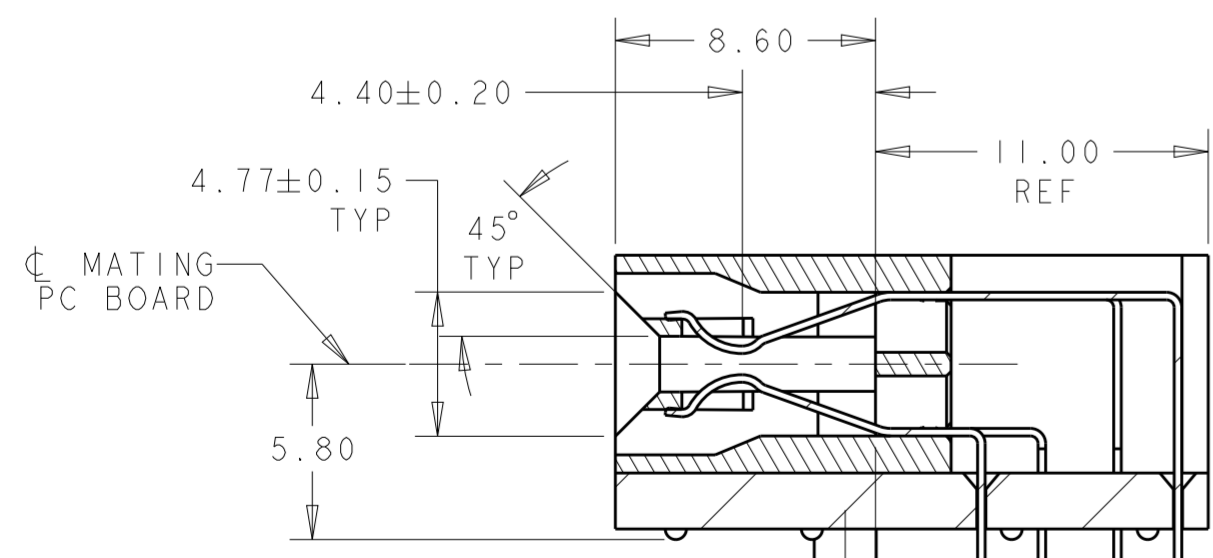
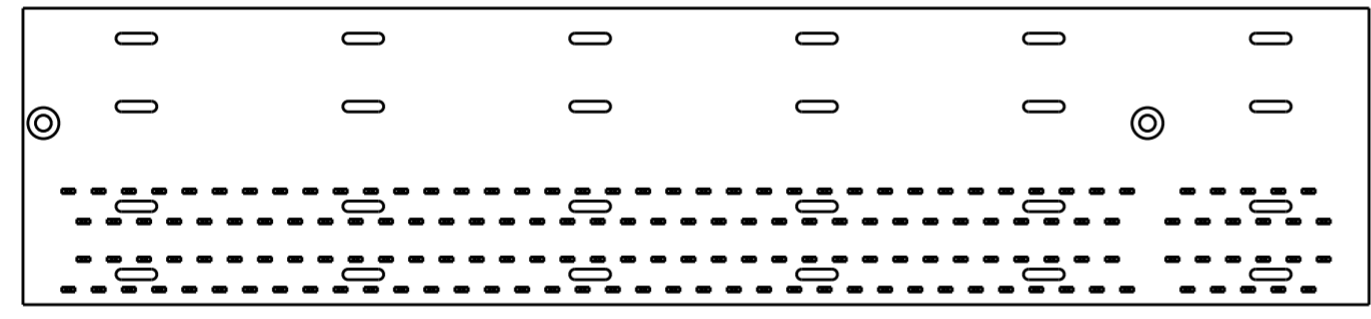

FINISH	N	E	D	C	B	A	POSN	PORT	PART NO
3	128.00	130.15	3.56	131.15	147.00	129.65	280	-	5-1761465-5
3	70.00	72.15	3.56	73.15	89.00	71.65	164	16	5-1761465-4
3	37.00	39.15	3.56	40.15	56.00	38.65	98	8	5-1761465-3
3	20.00	22.15	3.56	23.15	39.00	21.65	64	4	5-1761465-2
3	6.00	8.15	3.56	9.15	25.00	7.65	36	1	5-1761465-1
2	128.00	130.15	3.56	131.15	147.00	129.65	280	-	4-1761465-5
2	70.00	72.15	3.56	73.15	89.00	71.65	164	16	4-1761465-4
2	37.00	39.15	3.56	40.15	56.00	38.65	98	8	4-1761465-3
2	20.00	22.15	3.56	23.15	39.00	21.65	64	4	4-1761465-2
2	6.00	8.15	3.56	9.15	25.00	7.65	36	1	4-1761465-1
3	128.00	130.15	3.10	131.15	147.00	129.65	280	-	3-1761465-5
3	70.00	72.15	3.10	73.15	89.00	71.65	164	16	3-1761465-4
3	37.00	39.15	3.10	40.15	56.00	38.65	98	8	3-1761465-3
3	20.00	22.15	3.10	23.15	39.00	21.65	64	4	3-1761465-2
3	6.00	8.15	3.10	9.15	25.00	7.65	36	1	3-1761465-1
3	128.00	130.15	2.30	131.15	147.00	129.65	280	-	2-1761465-5
3	70.00	72.15	2.30	73.15	89.00	71.65	164	16	2-1761465-4
3	37.00	39.15	2.30	40.15	56.00	38.65	98	8	2-1761465-3
3	20.00	22.15	2.30	23.15	39.00	21.65	64	4	2-1761465-2
3	6.00	8.15	2.30	9.15	25.00	7.65	36	1	2-1761465-1
2	128.00	130.15	3.10	131.15	147.00	129.65	280	-	1-1761465-5
2	70.00	72.15	3.10	73.15	89.00	71.65	164	16	1-1761465-4
2	37.00	39.15	3.10	40.15	56.00	38.65	98	8	1-1761465-3
2	20.00	22.15	3.10	23.15	39.00	21.65	64	4	1-1761465-2
2	6.00	8.15	3.10	9.15	25.00	7.65	36	1	1-1761465-1
2	128.00	130.15	2.30	131.15	147.00	129.65	280	-	1761465-5
2	70.00	72.15	2.30	73.15	89.00	71.65	164	16	1761465-4
2	37.00	39.15	2.30	40.15	56.00	38.65	98	8	1761465-3
2	20.00	22.15	2.30	23.15	39.00	21.65	64	4	1761465-2
2	6.00	8.15	2.30	9.15	25.00	7.65	36	1	1761465-1

THIS DRAWING IS A CONTROLLED DOCUMENT FOR TYCO ELECTRONICS CORPORATION  
 IT IS SUBJECT TO CHANGE AND THE CONTROLLING ENGINEERING ORGANIZATION  
 SHOULD BE CONTACTED FOR THE LATEST REVISION.

DWN: R. TREA 09SEP2004  
 CHK: D. DEFIBAUGH 09SEP2004  
 APVD: D. DEFIBAUGH 09SEP2004

PRODUCT SPEC: -  
 APPLICATION SPEC: -  
 WEIGHT: -

MATERIAL: 1

NAME: PCI EXPRESS CARD EDGE CONNECTOR ASSEMBLY  
 RIGHT ANGLE, 5.8mm SLOT HEIGHT  
 THROUGH HOLE, ExpressModule TYPE

SIZE: A2 CAGE CODE: 00779 DRAWING NO: C-1761465 RESTRICTED TO: -  
 SCALE: 2:1 SHEET 1 OF 3 REV C

CUSTOMER DRAWING

THIS DRAWING IS UNPUBLISHED. RELEASED FOR PUBLICATION 20  
 © COPYRIGHT 20 BY TYCO ELECTRONICS CORPORATION. ALL RIGHTS RESERVED.

LOC	DIST	REVISIONS					
GP	00	P	LTR	DESCRIPTION	DATE	DWN	APVD
		-		SEE SHEET 1			



RIGHT ANGLE, ExpressModule  
 PCB LAYOUT  
 SCALE 5:1

6 MANUFACTURING TOLERANCE FOR Ø0.70±0.05 DIAMETER FINISHED HOLE WITH SnPB PLATING:  
 DRILLED HOLE = Ø0.79±0.02  
 COPPER PLATING = 0.025-0.050  
 SnPB PLATING = 0.0038-0.0124  
 OR Ø0.715±0.050 FINISHED HOLE WITHOUT SnPB PLATING  
 DRILLED HOLE = Ø0.79±0.02  
 COPPER PLATING = 0.025-0.050

THIS DRAWING IS A CONTROLLED DOCUMENT FOR TYCO ELECTRONICS CORPORATION. IT IS SUBJECT TO CHANGE AND THE CONTROLLING ENGINEERING ORGANIZATION SHOULD BE CONTACTED FOR THE LATEST REVISION.		DWN R. TREA 09SEP2004	Tyco Electronics Harrisburg, PA 17105-3608	
DIMENSIONS: mm		CHK D. DEEIBAUGH 09SEP2004	NAME PCI EXPRESS CARD EDGE CONNECTOR ASSEMBLY RIGHT ANGLE, 5.8mm SLOT HEIGHT THROUGH HOLE, ExpressModule TYPE	
TOLERANCES UNLESS OTHERWISE SPECIFIED: 0 PLC ± 1 PLC ±0.5 2 PLC ±0.13 3 PLC ±0.013 4 PLC ± ANGLES ±2° FINISH		APVD D. DEEIBAUGH 09SEP2004	PRODUCT SPEC APPLICATION SPEC WEIGHT CUSTOMER DRAWING	
MATERIAL		SIZE A2	CAGE CODE 00779	DRAWING NO C-1761465
		SCALE 4:1		SHEET 2 OF 3
				REV C

THIS DRAWING IS UNPUBLISHED. RELEASED FOR PUBLICATION 20  
 © COPYRIGHT 20 BY TYCO ELECTRONICS CORPORATION. ALL RIGHTS RESERVED.

LOC	DIST	REVISIONS					
GP	00	P	LTR	DESCRIPTION	DATE	DWN	APVD
		-		SEE SHEET 1			



SEE SHEET 1

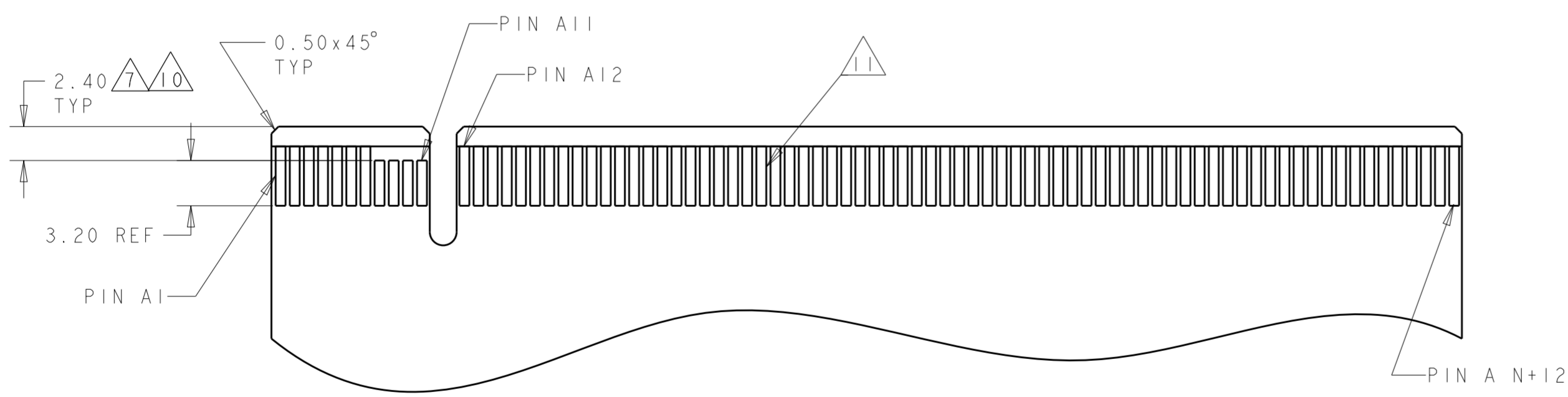

- 7 DIMENSION ONLY APPLIES TO "LAST MATE" PINS.
- 8 CARD THICKNESS APPLIES ACROSS PAD SURFACES AND INCLUDES PLATING AND/OR METALIZATION.
- 9 CHAMFER EDGES MUST BE FREE OF CUTTING BURRS.
- 10 NO TIE BAR PERMITTED FROM CARD EDGE TO LEADING EDGE OF "LAST MATE" PADS.
- 11 GOLD CONTACT PADS: ELECTROLESS GOLD PLATE 0.76µm MIN THICK OVER ELECTROLESS NICKEL PLATING 2µm MIN THICK.
- 12. PC BOARD SUPPLIER IS RESPONSIBLE FOR MAINTAINING ALL DIMENSIONS OF PC BOARD EDGE.
- 13 FLATNESS REQUIREMENT APPLIES FROM EDGE OF PC BOARD TO TOP OF KEY

ExpressModule LAYOUT (MATING PART ONLY)

A1, B17, B31, B48, B81	280	-
A1, B17, B31, B48, B81	164	16
A1, B17, B31, B48	98	8
A1, B17, B31	64	4
A1, B17	36	1
LAST MATE PINS	POS.	PORT

THIS DRAWING IS A CONTROLLED DOCUMENT FOR TYCO ELECTRONICS CORPORATION. IT IS SUBJECT TO CHANGE AND THE CONTROLLING ENGINEERING ORGANIZATION SHOULD BE CONTACTED FOR THE LATEST REVISION.		DWN R. TREA 09SEP2004	Tyco Electronics Harrisburg, PA 17105-3608	
DIMENSIONS: mm		CHK D. DEFLAUGH 09SEP2004	NAME PCI EXPRESS CARD EDGE CONNECTOR ASSEMBLY RIGHT ANGLE, 5.8mm SLOT HEIGHT THROUGH HOLE, ExpressModule TYPE	
TOLERANCES UNLESS OTHERWISE SPECIFIED: 0 PLC ±0.5 1 PLC ±0.13 2 PLC ±0.13 3 PLC ±0.013 4 PLC ±0.13 ANGLES ±2° FINISH		APVD D. DEFLAUGH 09SEP2004	SIZE A2	
MATERIAL		PRODUCT SPEC	CAGE CODE 00779	DRAWING NO C-1761465
		APPLICATION SPEC	RESTRICTED TO	
		WEIGHT	SCALE 4:1	SHEET 3 OF 3
		CUSTOMER DRAWING	REV C	

## Данный компонент на территории Российской Федерации

### Вы можете приобрести в компании MosChip.

Для оперативного оформления запроса Вам необходимо перейти по данной ссылке:

<http://moschip.ru/get-element>

Вы можете разместить у нас заказ для любого Вашего проекта, будь то серийное производство или разработка единичного прибора.

В нашем ассортименте представлены ведущие мировые производители активных и пассивных электронных компонентов.

Нашей специализацией является поставка электронной компонентной базы двойного назначения, продукции таких производителей как XILINX, Intel (ex.ALTERA), Vicor, Microchip, Texas Instruments, Analog Devices, Mini-Circuits, Amphenol, Glenair.

Сотрудничество с глобальными дистрибьюторами электронных компонентов, предоставляет возможность заказывать и получать с международных складов практически любой перечень компонентов в оптимальные для Вас сроки.

На всех этапах разработки и производства наши партнеры могут получить квалифицированную поддержку опытных инженеров.

Система менеджмента качества компании отвечает требованиям в соответствии с ГОСТ Р ИСО 9001, ГОСТ РВ 0015-002 и ЭС РД 009

### Офис по работе с юридическими лицами:

105318, г.Москва, ул.Щербаковская д.3, офис 1107, 1118, ДЦ «Щербаковский»

Телефон: +7 495 668-12-70 (многоканальный)

Факс: +7 495 668-12-70 (доб.304)

E-mail: [info@moschip.ru](mailto:info@moschip.ru)

Skype отдела продаж:

moschip.ru

moschip.ru\_4

moschip.ru\_6

moschip.ru\_9