

Specification

- Part No. : **AA.166.A.301111**
- Product Name : Ulysses Ultra Low Profile Magnetic Mount
GPS/GLONASS/Galileo/BeiDou Antenna
- Features : Dimensions: 37.8*40.4*10mm
Cable: 3m RG-174
Connector: SMA(M)
IP67 Rated
Cable Length and Connector Customizable
RoHS & REACH Compliant



1. Introduction

The Ulysses miniature ultra low profile (only 10mm in height) GNSS antenna is designed for applications which require high positioning accuracy by combining signals from GPS, GLONASS, Galileo and BeiDou systems. The tiny size of this antenna allows it to be used in very space restricted environments.

A high gain wide-band patch antenna on an integral ground delivers reliable performance. A fully IP67 waterproof rated and UV resistant enclosure allows use in outdoor environments. Mid SAW filter configuration eliminates potential LNA burn-out from nearby out of band radiated power bursts from other antennas that may be co-located nearby.

The antenna is manufactured to strict first tier Automotive quality controlled manufacturing process in IATF16949 approved facility. Custom cables and connectors available on request. Contact your regional Taoglas customer support team for more information.

2. Specification

GPS-Galileo-GLONASS-BeiDou					
Center Frequency	Galileo E1 1559 MHz	BeiDou 1561 MHz	GPS 1575.42±1.02 3 MHz	Galileo E2 1592 MHz	GLONASS 1602±5 MHz
Passive Antenna Efficiency (%)	46.13	51.33	34.56	49.74	44.55
Passive Antenna Average gain (dBi)	-3.36	-2.90	-4.61	-2.41	-3.51
Passive Antenna Peak gain	1.92	2.34	0.34	2.10	1.81
VSWR	<5				
Impedance	50Ω				
Axial Ratio	Galileo E1:28.94 Beidou:<27.29 GPS:<0.93 Galileo:< 7.76 GLONASS:< 16.15				
Polarization	RHCP				
LNA and Filter Electrical Properties					
Center Frequency	BeiDou:1561±2.046 MHz GPS:1575.42±1.023 MHz GLONASS:1602±5 MHz Galileo:1575.5±MHz				
Pout 1dB gain Compression point	-6dBm Min. -2 dbm Typ. (1561MHz,1575.42MHz,1602MHz,1559MHz-1592MHz)				
Output Impedance	50 Ohm				
VSWR	< 5:1				
Return Loss	-3 dB Max.				
LNA Gain, Current Draw, and Noise Figure @GPS	Frequency (MHz)	Voltage	LNA Gain(Typ)	Noise Figure(Typ)	
	1559	3-5V	31.37	3.24	
	1561		31.31	3.16	
	1575.42		29.75	2.66	
	1591		31.21	3.00	
1602	30.43		2.97		

MECHANICAL	
Antenna Dimensions	40.4 x 37.8 x 10mm
Housing Material	UV Resistant ABS
Cable	3m RG-174
Connector	SMA(M)
Magnet force	
ENVIRONMENTAL	
Operation Temperature	-40°C to 85°C
Storage Temperature	-40°C to 85°C
Humidity	Non-condensing 40°C 95% RH

3. Antenna Characteristics

3.1 GPS-GLONASS-GALILEO-BEIDOU Antenna

3.1.1 Block Diagram (Active antenna)

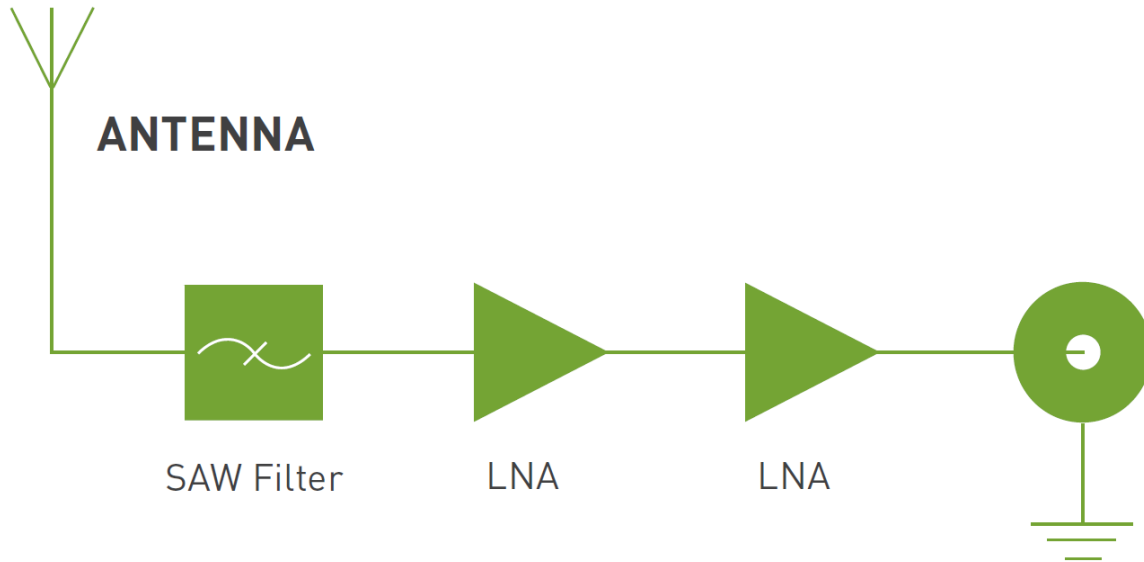

3.1.2 Test Setup

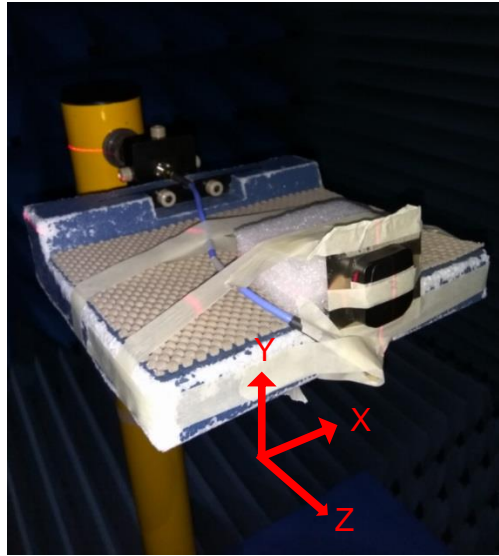

3.1.3 Return Loss (Passive antenna)

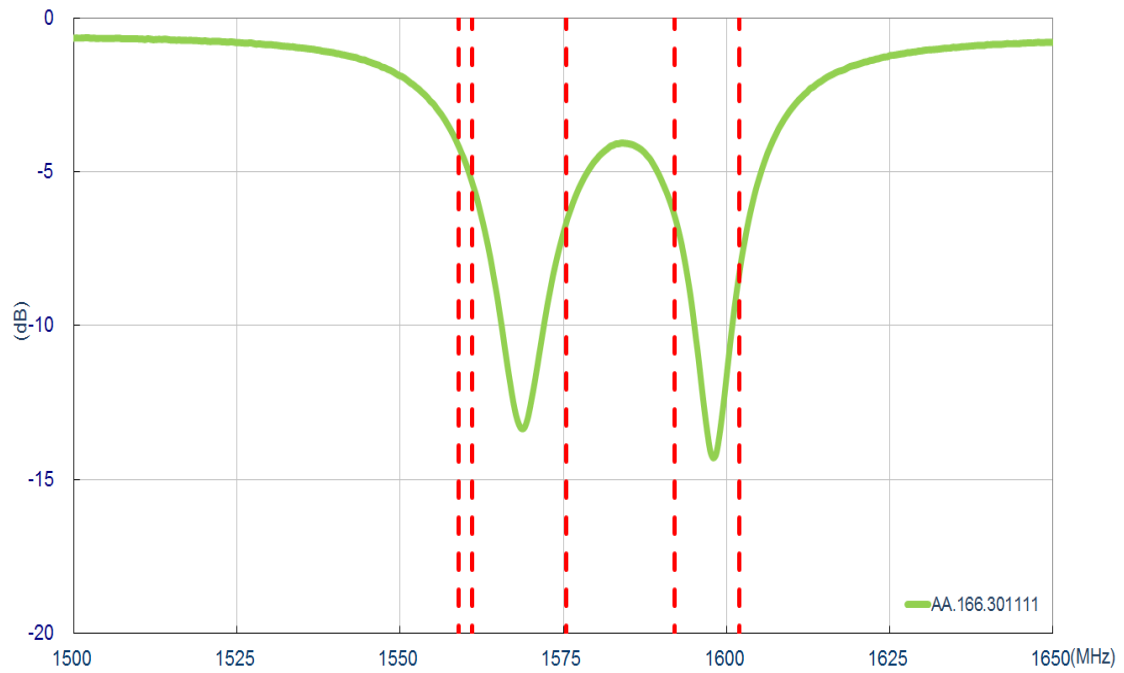

3.1.4 VSWR (Passive antenna)

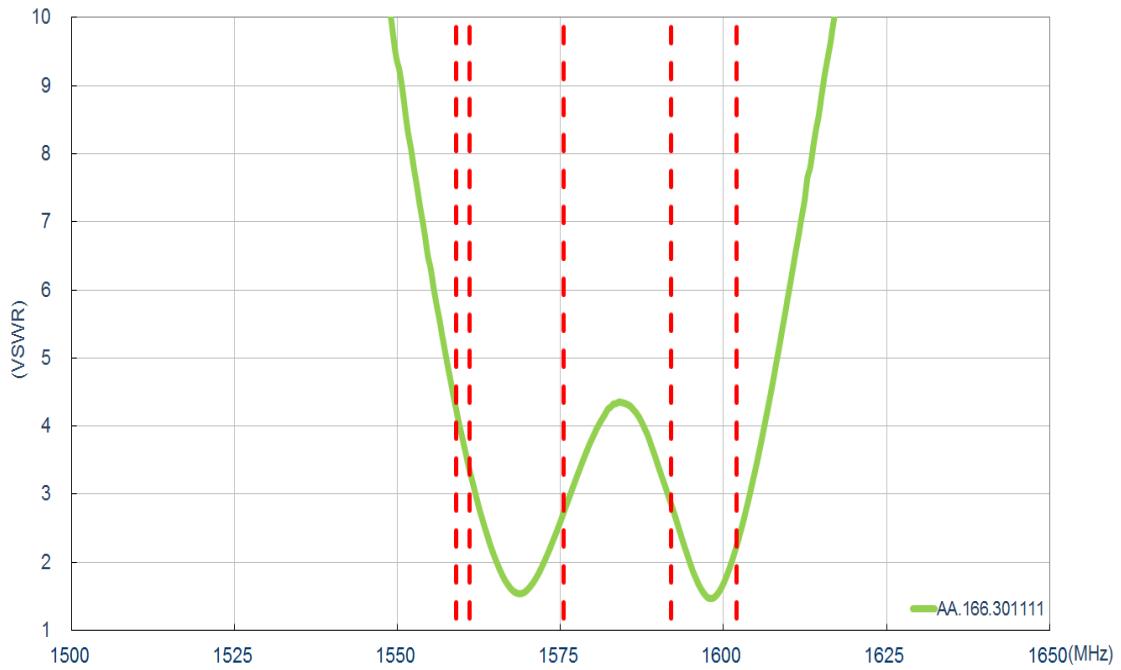

3.1.5 Smith Chart (Passive antenna)

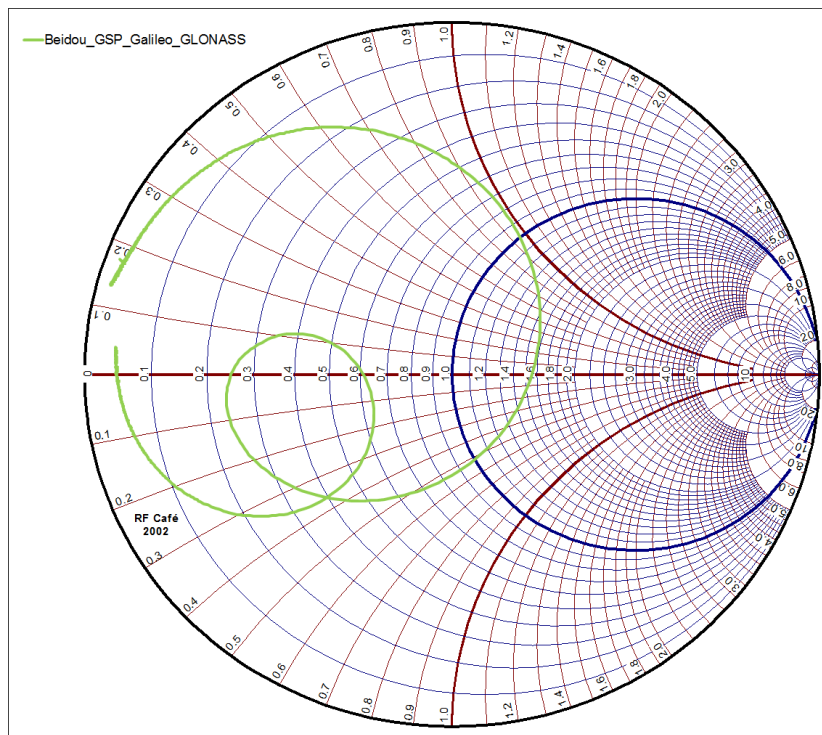

3.1.6 Efficiency (Passive antenna)

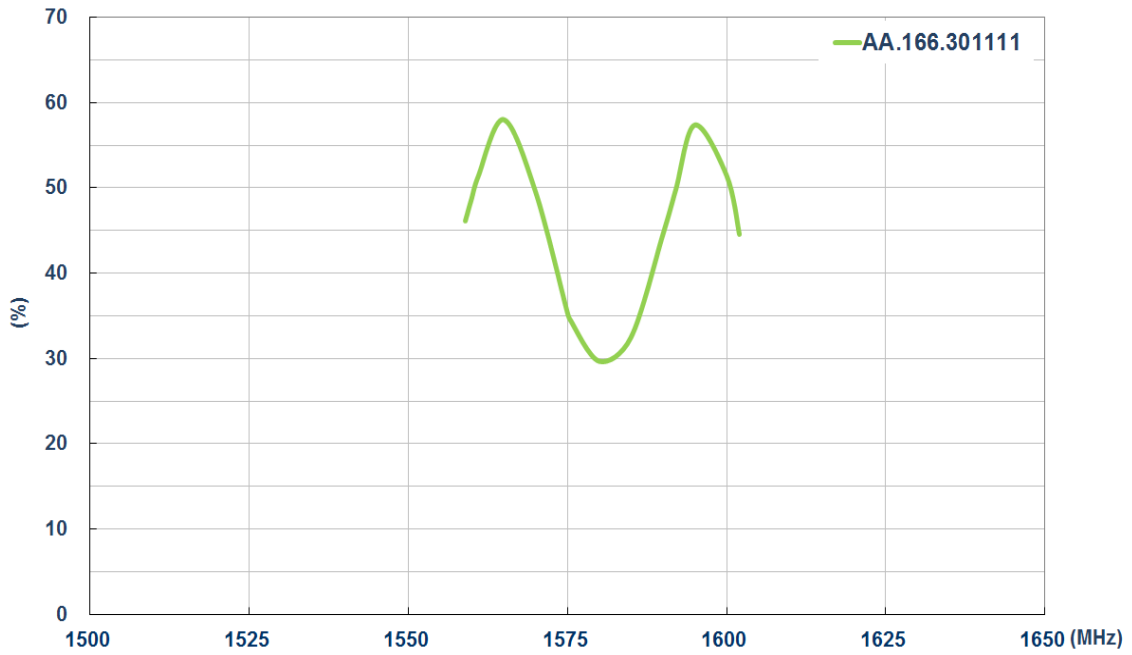

3.1.7 Average Gain (Passive antenna)

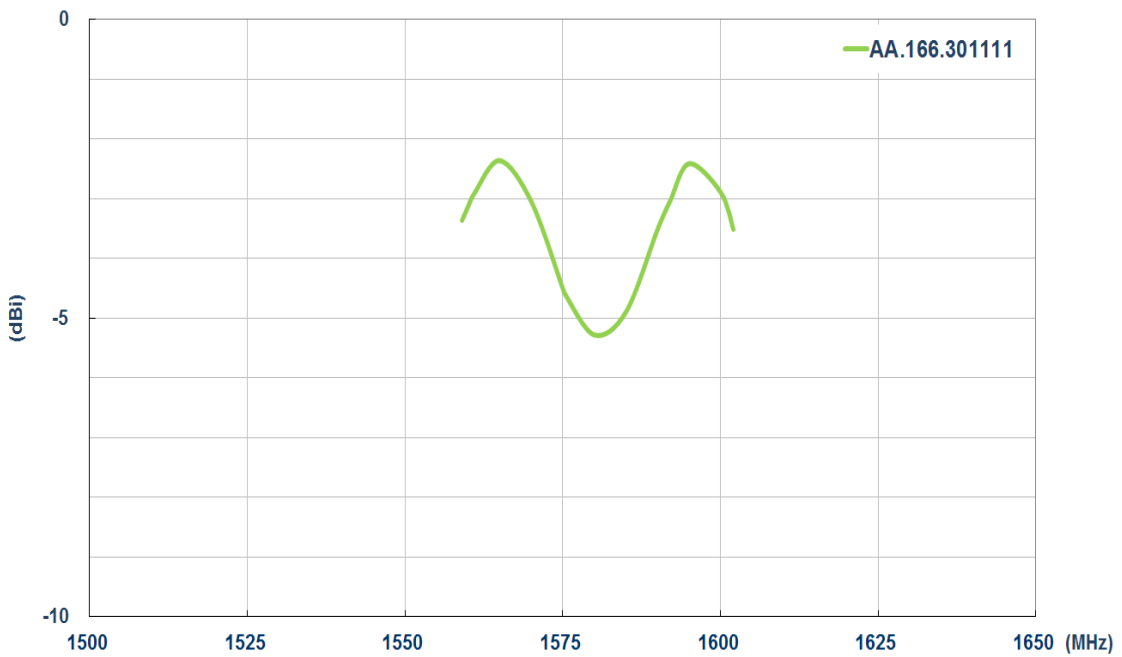

3.1.8 Peak Gain (Passive antenna)

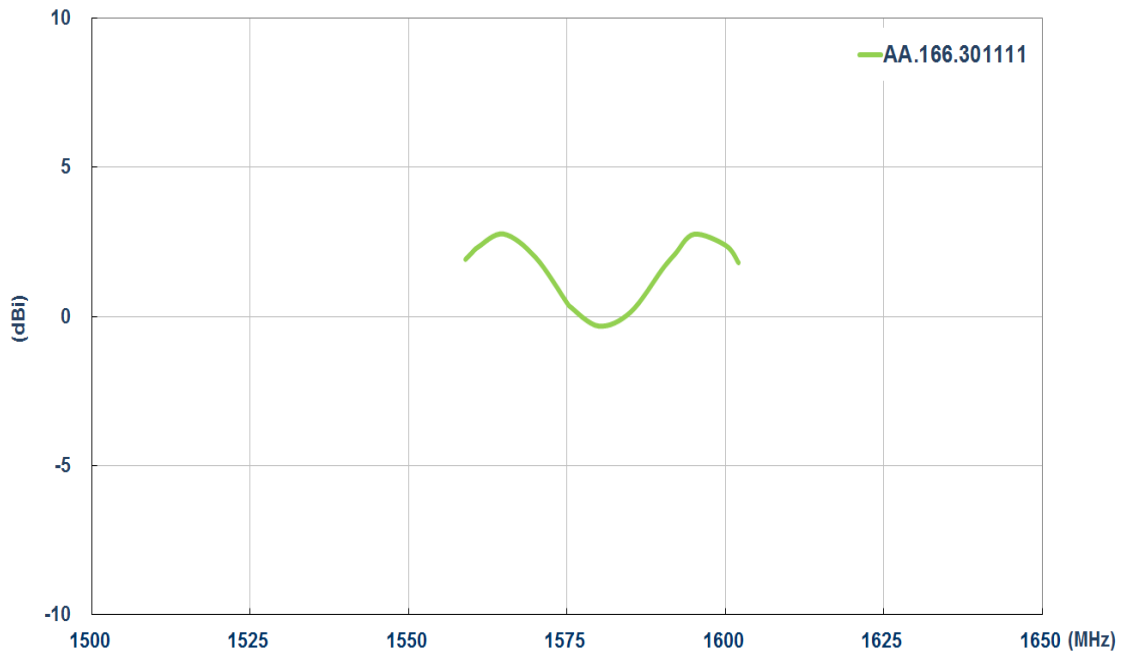

.1.9 Antenna Radiation Pattern (Passive antenna)
2D Radiation pattern

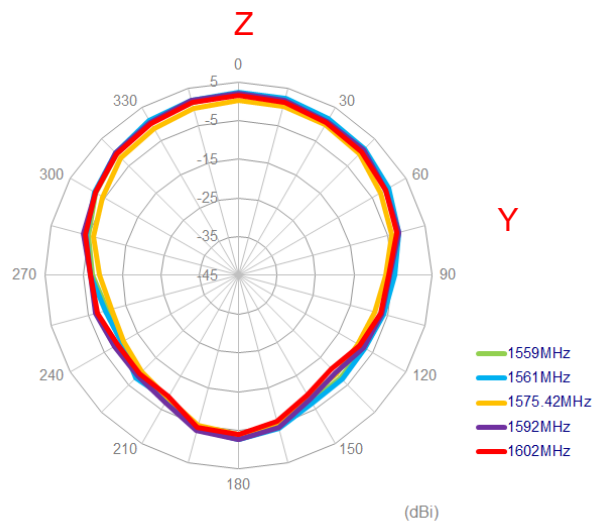
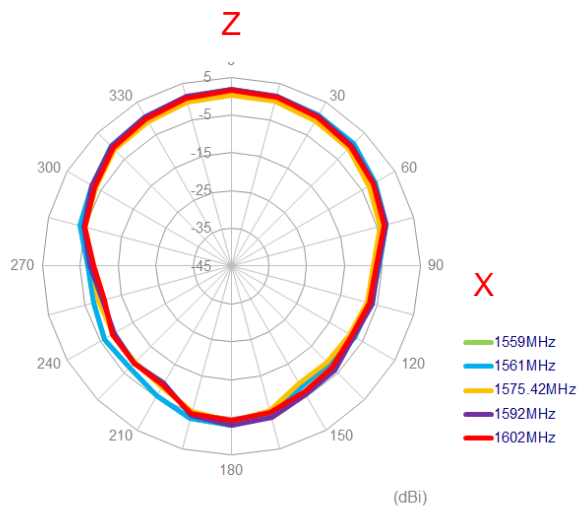
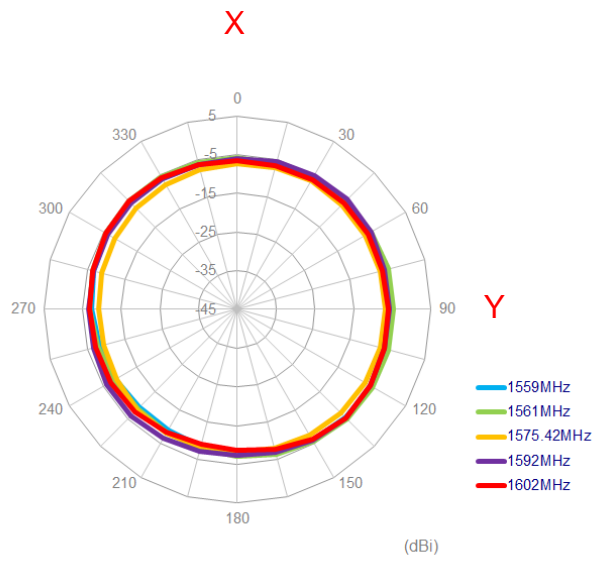

3.1.10 Axial Ratio Pattern (Passive antenna)

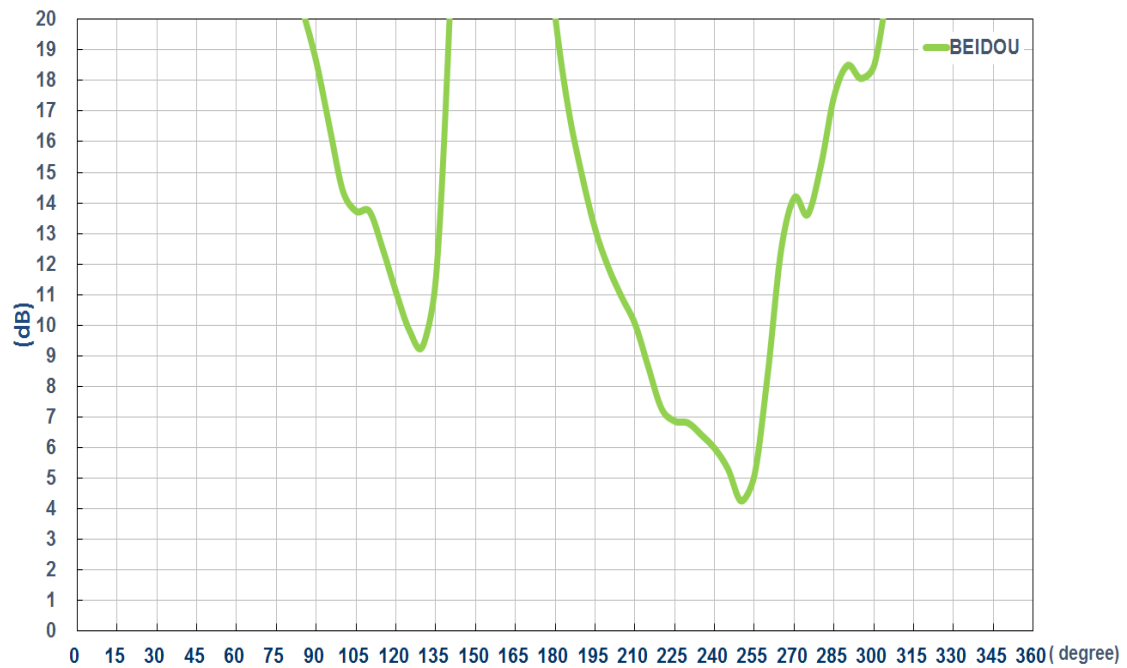
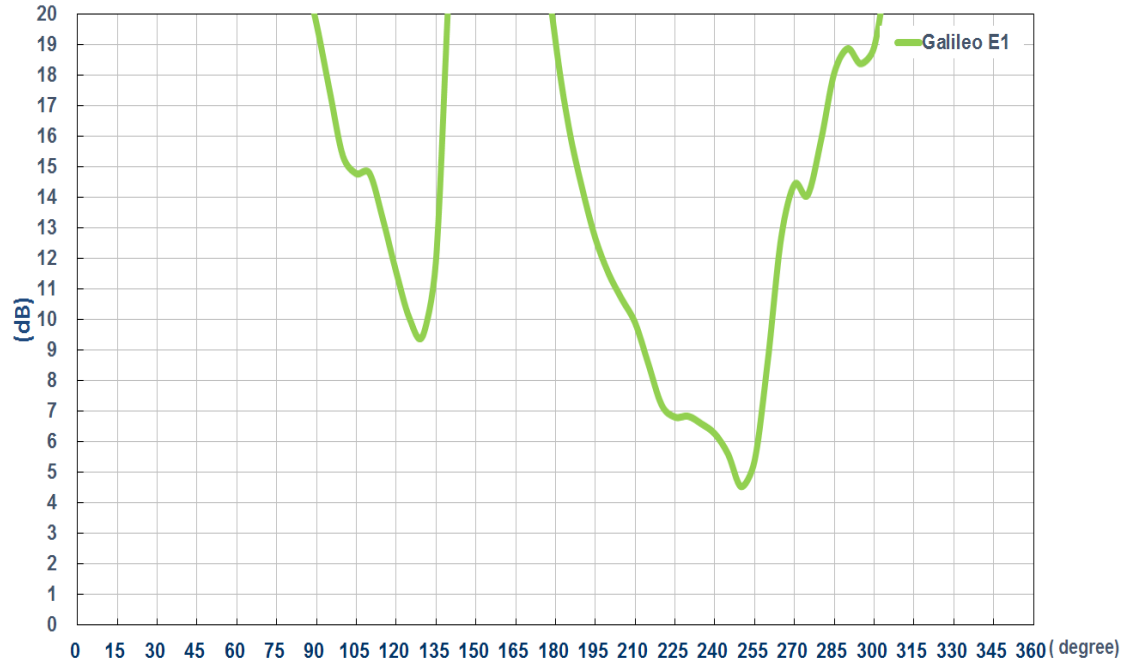

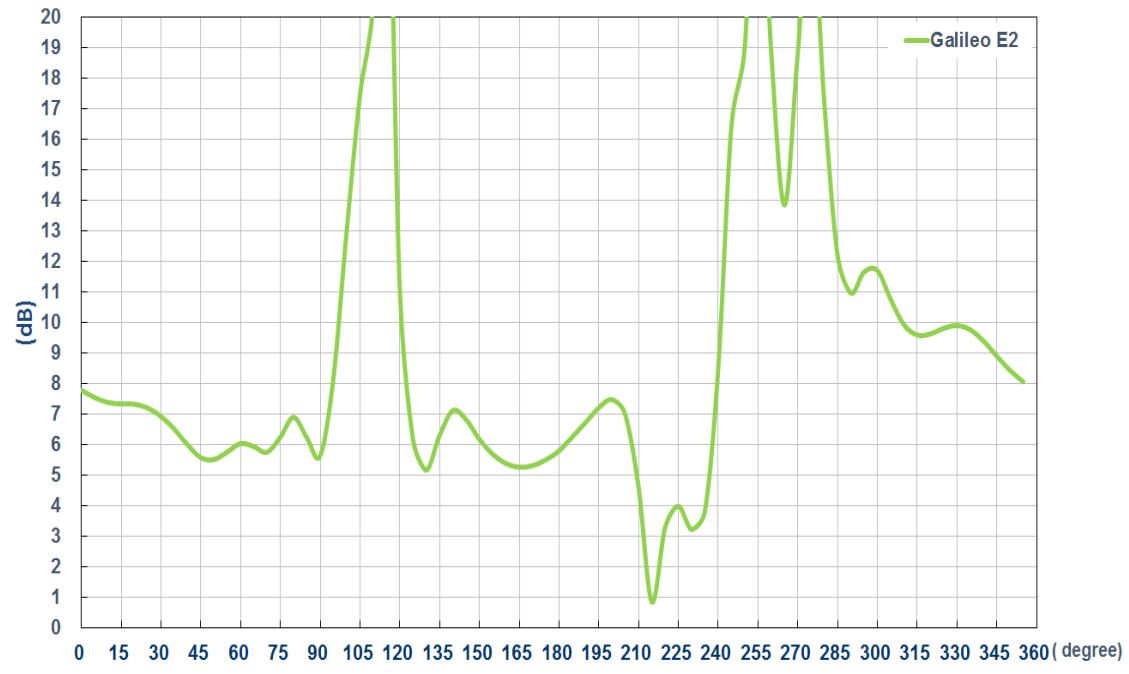
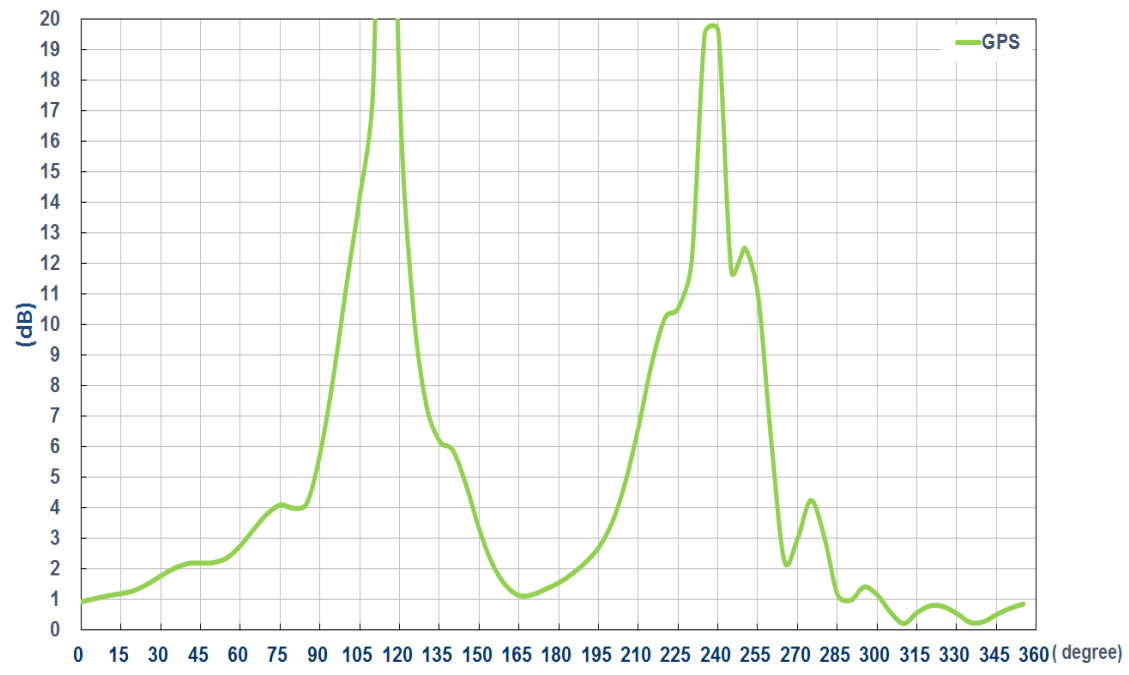

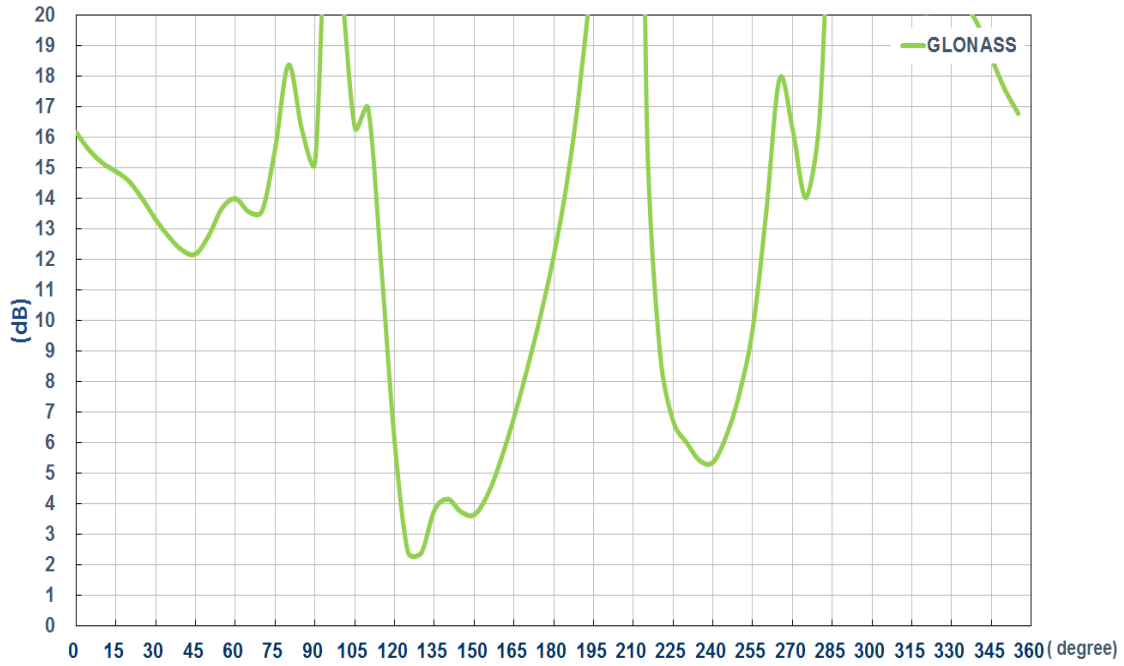

3.1.11 LNA Gain and Noise Figure (Active antenna)

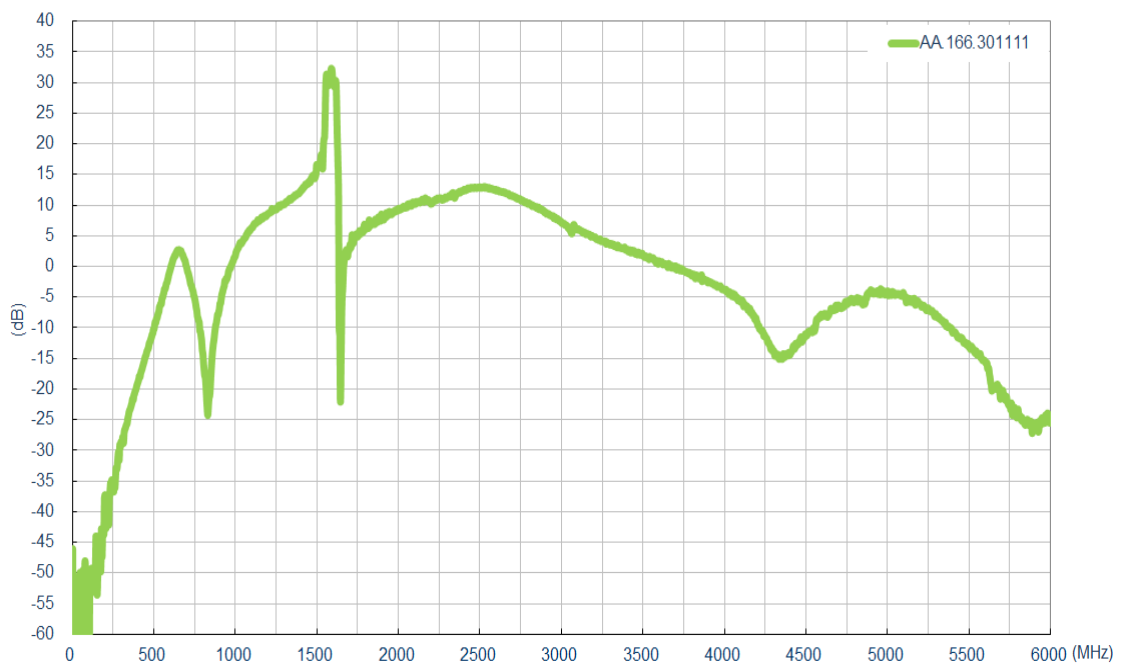

LNA Gain@3.0V

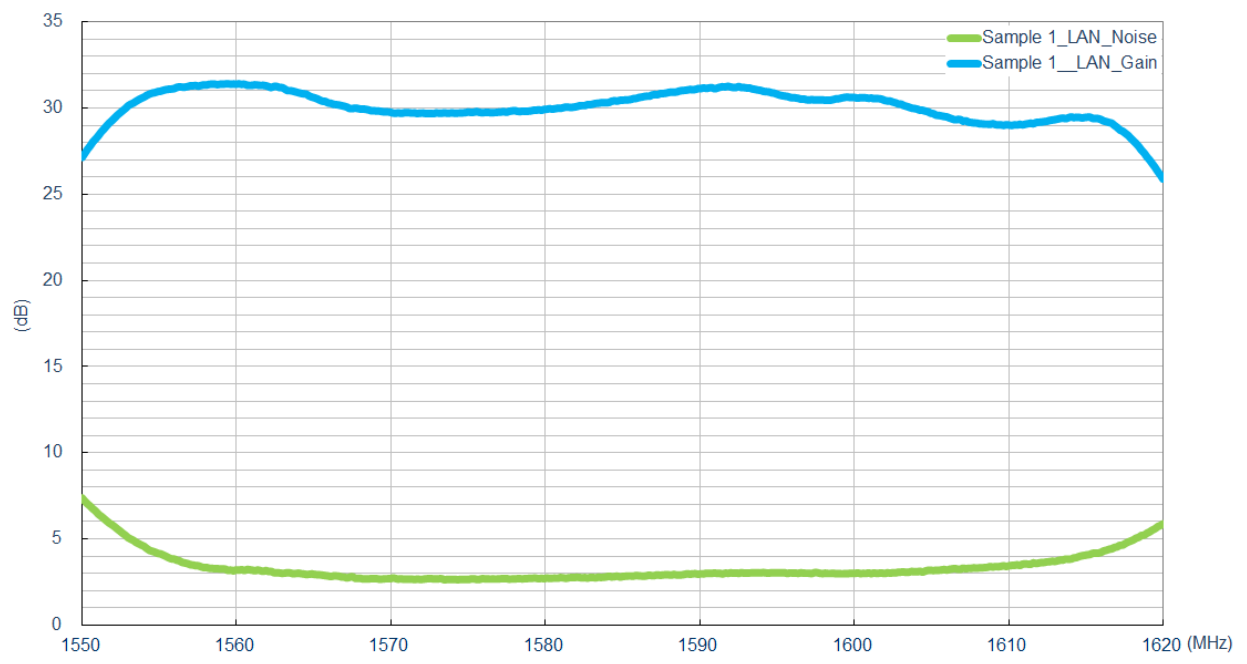

LNA Noise Figure @3.0V



4. Mechanical Drawing (Unit:mm)

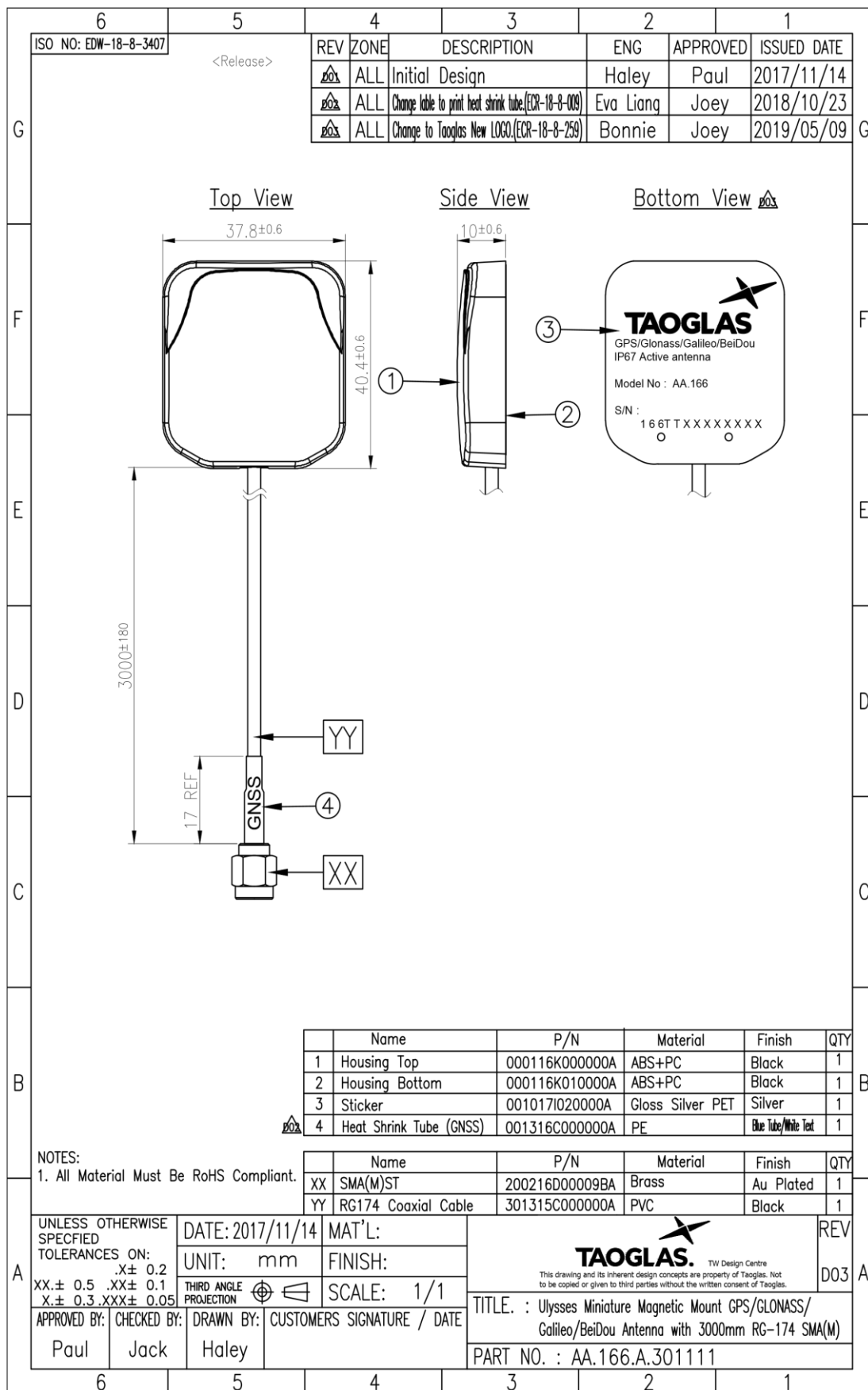

5. Packaging

1 pcs AA.166.A.301111 per PE bag
 PE Bag Dimensions - 100 x 200mm
 Weight - 65g

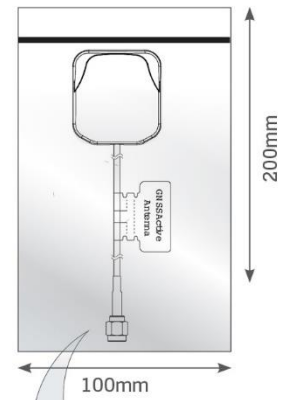

10 PE bags per large PE bags
 10 pcs AA.166.A.301111 per large PE bags
 Carton Dimensions - 420 x 220mm
 Weight - 0.65kg

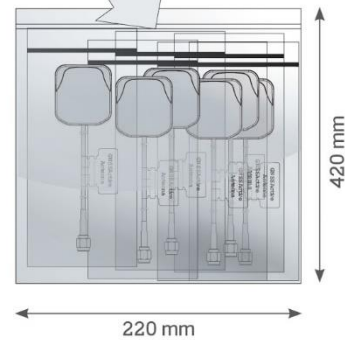

10 Large PE bags per carton
 100 pcs AA.166.A.301111 per carton
 Carton Dimensions - 380 x 380 x 310mm
 Weight - 7.5kg

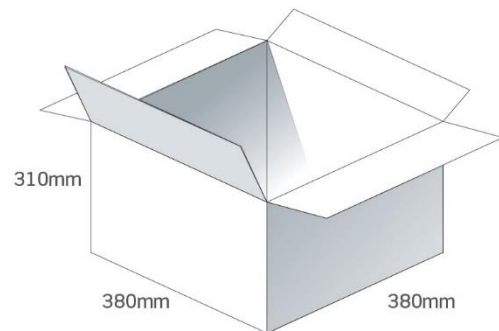

Taoglas makes no warranties based on the accuracy or completeness of the contents of this document and reserves the right to make changes to specifications and product descriptions at any time without notice. Taoglas reserves all rights to this document and the information contained herein.

Reproduction, use or disclosure to third parties without express permission is strictly prohibited.

© Taoglas

Данный компонент на территории Российской Федерации

Вы можете приобрести в компании MosChip.

Для оперативного оформления запроса Вам необходимо перейти по данной ссылке:

<http://moschip.ru/get-element>

Вы можете разместить у нас заказ для любого Вашего проекта, будь то серийное производство или разработка единичного прибора.

В нашем ассортименте представлены ведущие мировые производители активных и пассивных электронных компонентов.

Нашей специализацией является поставка электронной компонентной базы двойного назначения, продукции таких производителей как XILINX, Intel (ex.ALTERA), Vicor, Microchip, Texas Instruments, Analog Devices, Mini-Circuits, Amphenol, Glenair.

Сотрудничество с глобальными дистрибьюторами электронных компонентов, предоставляет возможность заказывать и получать с международных складов практически любой перечень компонентов в оптимальные для Вас сроки.

На всех этапах разработки и производства наши партнеры могут получить квалифицированную поддержку опытных инженеров.

Система менеджмента качества компании отвечает требованиям в соответствии с ГОСТ Р ИСО 9001, ГОСТ РВ 0015-002 и ЭС РД 009

Офис по работе с юридическими лицами:

105318, г.Москва, ул.Щербаковская д.3, офис 1107, 1118, ДЦ «Щербаковский»

Телефон: +7 495 668-12-70 (многоканальный)

Факс: +7 495 668-12-70 (доб.304)

E-mail: info@moschip.ru

Skype отдела продаж:

moschip.ru

moschip.ru_4

moschip.ru_6

moschip.ru_9