

19-OUTPUT PCIe GEN 3 BUFFER

Features

- Nineteen 0.7 V low-power, push-pull HCSL PCIe Gen 3 outputs
- 100 MHz /133 MHz PLL operation, supports PCIe and QPI
- PLL bandwidth SW SMBUS programming overrides the latch value from HW pin
- 9 selectable SMBUS addresses
- SMBus address configurable to allow multiple buffers in a single control network 3.3 V supply voltage operation
- Separate VDDIO for outputs
- PLL or bypass mode
- Spread spectrum tolerable
- 1.05 to 3.3 V I/O supply voltage
- 50 ps output-to-output skew
- 50 ps cyc-cyc jitter (PLL mode)
- Low phase jitter (Intel® QPI, PCIe Gen 1/Gen 2/Gen 3 compliant)
- 100 ps input-to-output delay
- Extended Temperature: -40 to 85 °C
- 72-pin QFN
- For variations of this device, contact Silicon Labs

Applications

- Server
- Storage
- Data center
- Enterprise switches and routers

Description

The Si53119 is a 19-output, low-power HCSL differential clock buffer that meets all of the performance requirements of the Intel DB1200ZL specification. The device is optimized for distributing reference clocks for Intel® QuickPath Interconnect (Intel QPI), PCIe Gen 1/Gen 2/Gen 3, SAS, SATA, and Intel Scalable Memory Interconnect (Intel SMI) applications. The VCO of the device is optimized to support 100 MHz and 133 MHz operation. Each differential output can be enabled through I²C for maximum flexibility and power savings.

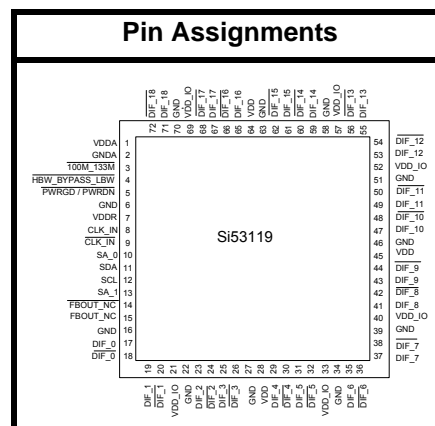
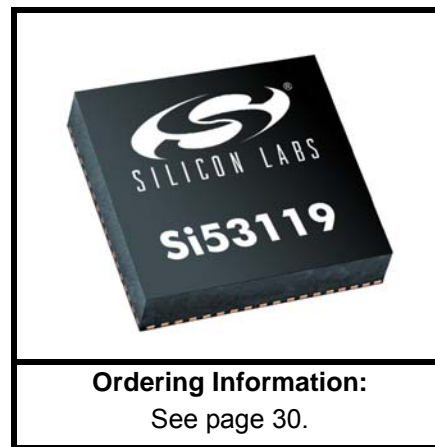

Patents pending

Si53119

Functional Block Diagram

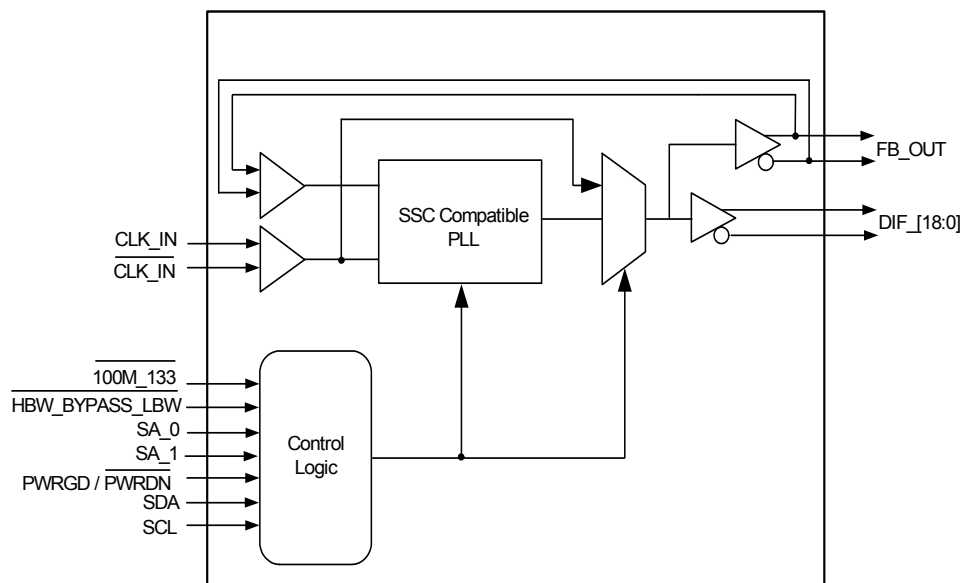

TABLE OF CONTENTS

<u>Section</u>	<u>Page</u>
1. Electrical Specifications	4
2. Functional Description	12
2.1. CLK_IN, CLK_IN	12
2.2. 100M_133M—Frequency Selection	12
2.3. SA_0, SA_1—Address Selection	12
2.4. CKPWRGD/PWRDN	13
2.5. HBW_BYPASS_LBW	14
2.6. Miscellaneous Requirements	15
3. Test and Measurement Setup	16
3.1. Input Edge	16
3.2. Termination of Differential Outputs	17
4. Control Registers	18
4.1. Byte Read/Write	18
4.2. Block Read/Write	19
4.3. Control Registers	20
5. Pin Descriptions: 72-Pin QFN	25
6. Power Filtering Example	29
6.1. Ferrite Bead Power Filtering	29
7. Ordering Guide	30
8. Package Outline	31
9. Land Pattern: 72-pin QFN	32
Contact Information	33

1. Electrical Specifications

Table 1. DC Operating Characteristics

$V_{DD_A} = 3.3\text{ V} \pm 5\%$, $V_{DD} = 3.3\text{ V} \pm 5\%$

Parameter	Symbol	Test Condition	Min	Max	Unit
3.3 V Core Supply Voltage	VDD/VDD_A	3.3 V $\pm 5\%$	3.135	3.465	V
3.3 V I/O Supply Voltage ¹	VDD_IO	1.05 V to 3.3 V $\pm 5\%$	0.9975	3.465	V
3.3 V Input High Voltage	V _{IH}	VDD	2.0	VDD+0.3	V
3.3 V Input Low Voltage	V _{IL}		VSS-0.3	0.8	V
Input Leakage Current ²	I _{IL}	0 < V _{IN} < VDD	-5	+5	μA
3.3 V Input High Voltage ³	V _{IH_FS}	VDD	0.7	VDD+0.3	V
3.3 V Input Low Voltage ³	V _{IL_FS}		VSS-0.3	0.35	V
3.3 V Input Low Voltage	V _{IL_Tri}		0	0.9	V
3.3 V Input Med Voltage	V _{IM_Tri}		1.3	1.8	V
3.3 V Input High Voltage	V _{IH_Tri}		2.4	VDD	V
3.3 V Output High Voltage ⁴	V _{OH}	I _{OH} = -1 mA	2.4	—	V
3.3 V Output Low Voltage ⁴	V _{OL}	I _{OL} = 1 mA	—	0.4	V
Input Capacitance ⁵	C _{IN}		2.5	4.5	pF
Output Capacitance ⁵	C _{OUT}		2.5	4.5	pF
Pin Inductance	L _{PIN}		—	7	nH
Ambient Temperature	T _A	No Airflow	0	70	$^{\circ}\text{C}$

Notes:

1. VDD_IO applies to the low-power NMOS push-pull HCSL compatible outputs.
2. Input Leakage Current does not include inputs with pull-up or pull-down resistors. Inputs with resistors should state current requirements.
3. Internal voltage reference is to be used to guarantee V_{IH_FS} and V_{IL_FS} threshold levels over full operating range.
4. Signal edge is required to be monotonic when transitioning through this region.
5. C_{comp} capacitance based on pad metallization and silicon device capacitance. Not including pin capacitance.

Table 2. SMBus Characteristics

Parameter	Symbol	Test Condition	Min	Max	Unit
SMBus Input Low Voltage ¹	V_{ILSMB}			0.8	V
SMBus Input High Voltage ¹	V_{IHSMB}		2.1	V_{DDSMB}	V
SMBus Output Low Voltage ¹	V_{OLSMB}	@ I_{PULLUP}		0.4	V
Nominal Bus Voltage ¹	V_{DDSMB}	@ V_{OL}	2.7	5.5	V
SMBus sink Current ¹	I_{PULLUP}	3 V to 5 V +/-10%	4		mA
SCLK/SDAT Rise Time ¹	t_{RSMB}	(Max $V_{IL} - 0.15$) to (Min $V_{IH} + 0.15$)		1000	ns
SCLK/SDAT Fall Time ¹	t_{FSMB}	(Min $V_{IH} + 0.15$) to (Max $V_{IL} - 0.15$)		300	ns
SMBus Operating Frequency ^{1,2}	f_{MINSMB}	Minimum Operating Frequency	100		kHz

Notes:

- Guaranteed by design and characterization
- The differential input clock must be running for the SMBus to be active

Table 3. Current Consumption

$T_A = 0-70\text{ }^\circ\text{C}$; supply voltage $V_{DD} = 3.3\text{ V} \pm 5\%$

Parameter	Symbol	Test Condition	Min	Typ	Max	Unit
Operating Current	IDD_{VDD}	100 MHz, VDD Rail	—	25	35	mA
	IDD_{VDDA}	100 MHz, VDDA + VDDR, PLL Mode	—	16	20	mA
	IDD_{VDDIO}	100 MHz, CL = Full Load, VDD IO Rail	—	130	150	mA
Power Down Current	IDD_{VDDPD}	Power Down, VDD Rail	—	1.5	2	mA
	IDD_{VDDAPD}	Power Down, VDDA Rail	—	8	12	mA
	$IDD_{VDDIOPD}$	Power Down, VDD_IO Rail	—	0.17	0.5	mA

Table 4. Clock Input Parameters

$T_A = 0-70\text{ }^\circ\text{C}$; supply voltage $V_{DD} = 3.3\text{ V} \pm 5\%$

Parameter	Symbol	Test Condition	Min	Typ	Max	Unit
Input High Voltage	V_{IHDIF}	Differential Inputs (singled-ended measurement)	600	700	1150	mV
Input Low Voltage	V_{IHDIF}	Differential Inputs (singled-ended measurement)	$V_{SS}-300$	0	300	mV
Input Common Mode Voltage	V_{com}	Common mode input voltage	300		1000	mV
Input Amplitude, CLK_IN	V_{swing}	Peak to Peak Value	300		1450	mV
Input Slew Rate, CLK_IN	dv/dt	Measured differentially	0.4		8	V/ns
Input Duty Cycle		Measurement from differential wave form	45	50	55	%
Input Jitter–Cycle to Cycle	J_{DFin}	Differential measurement			125	ps
Input Frequency	F_{ibyp}	$V_{DD} = 3.3\text{ V}$, bypass mode	33		150	MHz
	F_{iPLL}	$V_{DD} = 3.3\text{ V}$, 100 MHz PLL Mode	90	100	110	MHz
	F_{iPLL}	$V_{DD} = 3.3\text{ V}$, 133.33 MHz PLL Mode	120	133.33	147	MHz
Input SS Modulation Rate	f_{MODIN}	Triangle wave modulation	30	31.5	33	kHz

Table 5. Output Skew, PLL Bandwidth and PeakingT_A = 0–70 °C; supply voltage V_{DD} = 3.3 V ±5%

Parameter	Test Condition	Min	TYP	Max	Unit
CLK_IN, DIF[x:0]	Input-to-Output Delay in PLL Mode Nominal Value ^{1,2,3,4}	–100	18	100	ps
CLK_IN, DIF[x:0]	Input-to-Output Delay in Bypass Mode Nominal Value ^{2,4,5}	2.5	3.6	4.5	ns
CLK_IN, DIF[x:0]	Input-to-Output Delay Variation in PLL mode Over Voltage and Temperature ^{2,4,5}	–50	20	50	ps
CLK_IN, DIF[x:0]	Input-to-Output Delay Variation in Bypass Mode Over Voltage and Temperature ^{2,4,5}	–250		250	ps
DIF[11:0]	Output-to-Output Skew across all 19 Outputs (Common to Bypass and PLL Mode) ^{1,2,3,4,5}	0	20	50	ps
PLL Jitter Peaking	(HBW_BYPASS_LBW = 0) ⁶	—	0.4	2.0	dB
PLL Jitter Peaking	(HBW_BYPASS_LBW = 1) ⁶	—	0.1	2.5	dB
PLL Bandwidth	(HBW_BYPASS_LBW = 0) ⁷	—	0.7	1.4	MHz
PLL Bandwidth	(HBW_BYPASS_LBW = 1) ⁷	—	2	4	MHz

Notes:

1. Measured into fixed 2 pF load cap. Input-to-output skew is measured at the first output edge following the corresponding input.
2. Measured from differential cross-point to differential cross-point.
3. This parameter is deterministic for a given device.
4. Measured with scope averaging on to find mean value.
5. All Bypass Mode Input-to-Output specs refer to the timing between an input edge and the specific output edge created by it.
6. Measured as maximum pass band gain. At frequencies within the loop BW, highest point of magnification is called PLL jitter peaking.
7. Measured at 3 db down or half power point.

Table 6. Phase Jitter

Parameter	Test Condition	Min	Typ	Max	Unit
Phase Jitter PLL Mode	PCIe Gen 1 ^{1,2,3}	—	25	86	ps
	PCIe Gen 2 Low Band F < 1.5 MHz ^{1,3,4,5}	—	2.5	3.0	ps (RMS)
	PCIe Gen 2 High Band 1.5 MHz < F < Nyquist ^{1,3,4,5}	—	2.5	3.1	ps (RMS)
	PCIe Gen 3 (PLL BW 2–4 MHz, CDR = 10 MHz) ^{1,3,4,5}	—	0.5	1.0	ps (RMS)
	Intel® QPI & Intel SMI (4.8 Gbps or 6.4 Gb/s, 100 or 133 MHz, 12 UI) ^{1,6,7}	—	0.25	0.5	ps (RMS)
	Intel QPI & Intel SMI (8 Gb/s, 100 MHz, 12 UI) ^{1,6}	—	0.15	0.3	ps (RMS)
	Intel QPI & Intel SMI (9.6 Gb/s, 100 MHz, 12 UI) ^{1,6}	—	0.16	0.2	ps (RMS)
Additive Phase Jitter Bypass Mode	PCIe Gen 1 ^{1,2,3}	—	10	—	ps
	PCIe Gen 2 Low Band F < 1.5 MHz ^{1,3,4,5}	—	0.1	—	ps (RMS)
	PCIe Gen 2 High Band 1.5 MHz < F < Nyquist ^{1,3,4,5}	—	0.1	—	ps (RMS)
	PCIe Gen 3 (PLL BW 2–4 MHz, CDR = 10 MHz) ^{1,3,4,5}	—	0.3	—	ps (RMS)
	Intel QPI & Intel® SMI (4.8 Gbps or 6.4 Gb/s, 100 or 133 MHz, 12 UI) ^{1,6,7}	—	0.15	—	ps (RMS)
	Intel QPI & Intel® SMI (8 Gb/s, 100 MHz, 12 UI) ^{1,6}	—	0.1	—	ps (RMS)
	Intel QPI & Intel® SMI (9.6 Gb/s, 100 MHz, 12 UI) ^{1,6}	—	0.1	—	ps (RMS)

Notes:

1. Post processed evaluation through Intel supplied Matlab* scripts. Defined for a BER of 1E-12. Measured values at a smaller sample size have to be extrapolated to this BER target.
2. $\zeta = 0.54$ implies a jitter peaking of 3 dB.
3. PCIe* Gen 3 filter characteristics are subject to final ratification by PCISIG. Check the PCI-SIG for the latest specification.
4. Measured on 100 MHz PCIe output using the template file in the Intel-supplied Clock Jitter Tool V1.6.3.
5. Measured on 100 MHz output using the template file in the Intel-supplied Clock Jitter Tool V1.6.3.
6. Measured on 100 MHz, 133 MHz output using the template file in the Intel-supplied Clock Jitter Tool V1.6.3.
7. These jitter numbers are defined for a BER of 1E-12. Measured numbers at a smaller sample size have to be extrapolated to this BER target.

Table 7. DIF 0.7 V AC Timing Characteristics (Non-Spread Spectrum Mode)¹

Parameter	Symbol	CLK 100 MHz, 133 MHz			Unit
		Min	Typ	Max	
Clock Stabilization Time ²	T _{STAB}	—	1.5	1.8	ms
Long Term Accuracy ^{3,4,5}	L _{ACC}	—	—	100	ppm
Absolute Host CLK Period (100 MHz) ^{3,4,6}	T _{ABS}	9.94900	—	10.05100	ns
Absolute Host CLK Period (133 MHz) ^{3,4,6}	T _{ABS}	7.44925	—	7.55075	ns
Slew Rate ^{3,4,7}	Edge_rate	1.0	3.0	4.0	V/ns
Rise Time Variation ^{3,8,9}	Δ Trise	—	—	125	ps
Fall Time Variation ^{3,8,9}	Δ Tfall	—	—	125	ps
Rise/Fall Matching ^{3,8,10,11}	T _{RISE_MAT} / T _{FALL_MAT}	—	7	20	%
Voltage High (typ 0.7 V) ^{3,8,12}	V _{HIGH}	660	750	850	mV

Notes:

1. Unless otherwise noted, all specifications in this table apply to all processor frequencies.
2. This is the time from the valid CLK_IN input clocks and the assertion of the PWRGD signal level at 1.8–2.0 V to the time that stable clocks are output from the buffer chip (PLL locked).
3. Test configuration is R_s = 33.2 Ω, 2 pF for 100 Ω transmission line; R_s = 27 Ω, 2 pF for 85 Ω transmission line.
4. Measurement taken from differential waveform.
5. Using frequency counter with the measurement interval equal or greater than 0.15 s, target frequencies are 99,750,00 Hz, 133,000,000 Hz.
6. The average period over any 1 μs period of time must be greater than the minimum and less than the maximum specified period.
7. Measure taken from differential waveform on a component test board. The edge (slew) rate is measured from –150 mV to +150 mV on the differential waveform. Scope is set to average because the scope sample clock is making most of the dynamic wiggles along the clock edge. Only valid for Rising clock and Falling C_{LOCK}. Signal must be monotonic through the Vol to Voh region for Trise and Tfall.
8. Measurement taken from single-ended waveform.
9. Measured with oscilloscope, averaging off, using min max statistics. Variation is the delta between min and max.
10. Measured with oscilloscope, averaging on. The difference between the rising edge rate (average) of clock verses the falling edge rate (average) of C_{LOCK}.
11. Rise/Fall matching is derived using the following, 2*(Trise – Tfall) / (Trise + Tfall).
12. VHigh is defined as the statistical average High value as obtained by using the Oscilloscope VHigh Math function.
13. VLow is defined as the statistical average Low value as obtained by using the Oscilloscope VLow Math function.
14. Measured at crossing point where the instantaneous voltage value of the rising edge of CLK equals the falling edge of CLK.
15. This measurement refers to the total variation from the lowest crossing point to the highest, regardless of which edge is crossing.
16. The crossing point must meet the absolute and relative crossing point specifications simultaneously.
17. Vcross(rel) Min and Max are derived using the following, Vcross(rel) Min = 0.250 + 0.5 (Vhavg – 0.700), Vcross(rel) Max = 0.550 – 0.5 (0.700 – Vhavg), (see Figures 3–4 for further clarification).
18. ΔVcross is defined as the total variation of all crossing voltages of Rising C_{CLOCK} and Falling C_{CLOCK}. This is the maximum allowed variance in Vcross for any particular system.
19. Overshoot is defined as the absolute value of the maximum voltage.
20. Undershoot is defined as the absolute value of the minimum voltage.

Table 7. DIF 0.7 V AC Timing Characteristics (Non-Spread Spectrum Mode)¹ (Continued)

Parameter	Symbol	CLK 100 MHz, 133 MHz			Unit
		Min	Typ	Max	
Voltage Low (Typ 0.7 V) ^{3,8,13}	V _{LOW}	-150	15	150	mV
Maximum Voltage ⁸	V _{MAX}	—	850	1150	mV
Minimum Voltage	V _{MIN}	-300	—	—	mV
Absolute Crossing Point Voltages ^{3,8,14,15,16}	V _{OXABS}	300	450	550	mV
Total Variation of Vcross Over All Edges ^{3,8,18}	Total Δ Vox	—	14	140	mV
Duty Cycle ^{3,4}	DC	45	—	55	%
Maximum Voltage (Overshoot) ^{3,8,19}	V _{ovs}	—	—	V _{High} + 0.3	V
Maximum Voltage (Undershoot) ^{3,8,20}	V _{uds}	—	—	V _{Low} - 0.3	V
Ringback Voltage ^{3,8}	V _{rb}	0.2	—	N/A	V

Notes:

1. Unless otherwise noted, all specifications in this table apply to all processor frequencies.
2. This is the time from the valid CLK_IN input clocks and the assertion of the PWRGD signal level at 1.8–2.0 V to the time that stable clocks are output from the buffer chip (PLL locked).
3. Test configuration is R_s = 33.2 Ω , 2 pF for 100 Ω transmission line; R_s = 27 Ω , 2 pF for 85 Ω transmission line.
4. Measurement taken from differential waveform.
5. Using frequency counter with the measurement interval equal or greater than 0.15 s, target frequencies are 99,750,00 Hz, 133,000,000 Hz.
6. The average period over any 1 μ s period of time must be greater than the minimum and less than the maximum specified period.
7. Measure taken from differential waveform on a component test board. The edge (slew) rate is measured from -150 mV to +150 mV on the differential waveform. Scope is set to average because the scope sample clock is making most of the dynamic wiggles along the clock edge. Only valid for Rising clock and Falling CLOCK. Signal must be monotonic through the Vol to Voh region for Trise and Tfall.
8. Measurement taken from single-ended waveform.
9. Measured with oscilloscope, averaging off, using min max statistics. Variation is the delta between min and max.
10. Measured with oscilloscope, averaging on. The difference between the rising edge rate (average) of clock verses the falling edge rate (average) of CLOCK.
11. Rise/Fall matching is derived using the following, $2*(Trise - Tfall) / (Trise + Tfall)$.
12. V_{High} is defined as the statistical average High value as obtained by using the Oscilloscope V_{High} Math function.
13. V_{Low} is defined as the statistical average Low value as obtained by using the Oscilloscope V_{Low} Math function.
14. Measured at crossing point where the instantaneous voltage value of the rising edge of CLK equals the falling edge of CLK.
15. This measurement refers to the total variation from the lowest crossing point to the highest, regardless of which edge is crossing.
16. The crossing point must meet the absolute and relative crossing point specifications simultaneously.
17. V_{cross(rel)} Min and Max are derived using the following, V_{cross(rel)} Min = 0.250 + 0.5 (V_{havg} - 0.700), V_{cross(rel)} Max = 0.550 - 0.5 (0.700 - V_{havg}), (see Figures 3–4 for further clarification).
18. Δ V_{cross} is defined as the total variation of all crossing voltages of Rising CLOCK and Falling CLOCK. This is the maximum allowed variance in V_{cross} for any particular system.
19. Overshoot is defined as the absolute value of the maximum voltage.
20. Undershoot is defined as the absolute value of the minimum voltage.

Table 8. Clock Periods Differential Clock Outputs with SSC Disabled

SSC OFF Center Freq, MHz	Measurement Window							Unit
	1 Clock	1 μ s	0.1 s	0.1 s	0.1 s	1 μ s	1 Clock	
	-C-C Jitter AbsPer Min	-SSC Short Term AVG Min	-ppm Long Term AVG Min	0 ppm Period Nominal	+ppm Long Term AVG Max	+SSC Short Term AVG Max	+C-C Jitter AbsPer Max	
100.00	9.94900		9.99900	10.00000	10.00100		10.05100	ns
133.33	7.44925		7.49925	7.50000	7.50075		7.55075	ns

Table 9. Clock Periods Differential Clock Outputs with SSC Enabled

SSC ON Center Freq, MHz	Measurement Window							Unit
	1 Clock	1 μ s	0.1 s	0.1 s	0.1 s	1 μ s	1 Clock	
	-C-C Jitter AbsPer Min	-SSC Short Term AVG Min	-ppm Long Term AVG Min	0 ppm Period Nominal	+ppm Long Term AVG Max	+SSC Short Term AVG Max	+C-C Jitter AbsPer Max	
99.75	9.94906	9.99906	10.02406	10.02506	10.02607	10.05107	10.10107	ns
133.33	7.44930	7.49930	7.51805	7.51880	7.51955	7.53830	7.58830	ns

Table 10. Absolute Maximum Ratings

Parameter	Symbol	Min	Max	Unit
3.3 V Core Supply Voltage ¹	VDD/VDD_A	—	4.6	V
3.3 V I/O Supply Voltage ¹	VDD_IO	—	4.6	V
3.3 V Input High Voltage ^{1,2}	VIH	—	4.6	V
3.3 V Input Low Voltage ¹	VIL	-0.5	—	V
Storage Temperature ¹	t_s	-65	150	°C
Input ESD protection ³	ESD	2000	—	V

Notes:

1. Consult manufacturer regarding extended operation in excess of normal dc operating parameters.
2. Maximum VIH is not to exceed maximum V_{DD}.
3. Human body model.

2. Functional Description

2.1. CLK_IN, $\overline{\text{CLK_IN}}$

The differential input clock is expected to be sourced from a clock synthesizer or PCH.

2.2. $\overline{\text{100M_133M}}$ —Frequency Selection

The Si53119 is optimized for lowest phase jitter performance at operating frequencies of 100 and 133 MHz. $\overline{\text{100M_133M}}$ is a hardware input pin, which programs the appropriate output frequency of the differential outputs. Note that the CLK_IN frequency must be equal to the $\overline{\text{CLK_OUT}}$ frequency; meaning Si53119 is operated in 1:1 mode only. Frequency selection can be enabled by the $\overline{\text{100M_133M}}$ hardware pin. An external pull-up or pull-down resistor is attached to this pin to select the input/output frequency. The functionality is summarized in Table 11.

Table 11. Frequency Program Table

$\overline{\text{100M_133M}}$	Optimized Frequency (DIF_IN = DIF_x)
0	133.33 MHz
1	100.00 MHz

Note: All differential outputs transition from 100 to 133 MHz or from 133 to 100 MHz in a glitch free manner.

2.3. SA_0, SA_1—Address Selection

SA_0 and SA_1 are tri-level hardware pins, which program the appropriate address for the Si53119. The two tri-level input pins that can configure the device to nine different addresses.

Table 12. SMBUS Address Table

SA_1	SA_0	SMBUS Address
L	L	D8
L	M	DA
L	H	DE
M	L	C2
M	M	C4
M	H	C6
H	L	CA
H	M	CC
H	H	CE

2.4. CKPWRGD/ $\overline{\text{PWRDN}}$

CKPWRGD is asserted high and deasserted low. Deassertion of PWRGD (pulling the signal low) is equivalent to indicating a power down condition. CKPWRGD (assertion) is used by the Si53119 to sample initial configurations, such as frequency select condition and SA selections. After CKPWRGD has been asserted high for the first time, the pin becomes a $\overline{\text{PWRDN}}$ (Power Down) pin that can be used to shut off all clocks cleanly and instruct the device to invoke power-saving mode. $\overline{\text{PWRDN}}$ is a completely asynchronous active low input. When entering power-saving mode, $\overline{\text{PWRDN}}$ should be asserted low prior to shutting off the input clock or power to ensure all clocks shut down in a glitch free manner. When $\overline{\text{PWRDN}}$ is asserted low, all clocks will be disabled prior to turning off the VCO. When $\overline{\text{PWRDN}}$ is deasserted high, all clocks will start and stop without any abnormal behavior and will meet all ac and dc parameters.

Note: The assertion and deassertion of $\overline{\text{PWRDN}}$ is absolutely asynchronous.

Warning: Disabling of the CLK_IN input clock prior to assertion of $\overline{\text{PWRDN}}$ is an undefined mode and not recommended. Operation in this mode may result in glitches, excessive frequency shifting, etc.

Table 13. CKPWRGD/ $\overline{\text{PWRDN}}$ Functionality

CKPWRGD/ PWRDN	DIF_IN/ DINF_IN#	SMBus EN bit	DIF-x/ DIF_x#	FBOUT_NC/ FBOUT_NC#	PLL State
0	X	X	Low/Low	Low/Low	OFF
1	Running	0	Low/Low	Running	ON
		1	Running	Running	ON

2.4.1. $\overline{\text{PWRDN}}$ Assertion

When $\overline{\text{PWRDN}}$ is sampled low by two consecutive rising edges of $\overline{\text{DIF}}$, all differential outputs must be held LOW/LOW on the next DIF high-to-low transition.

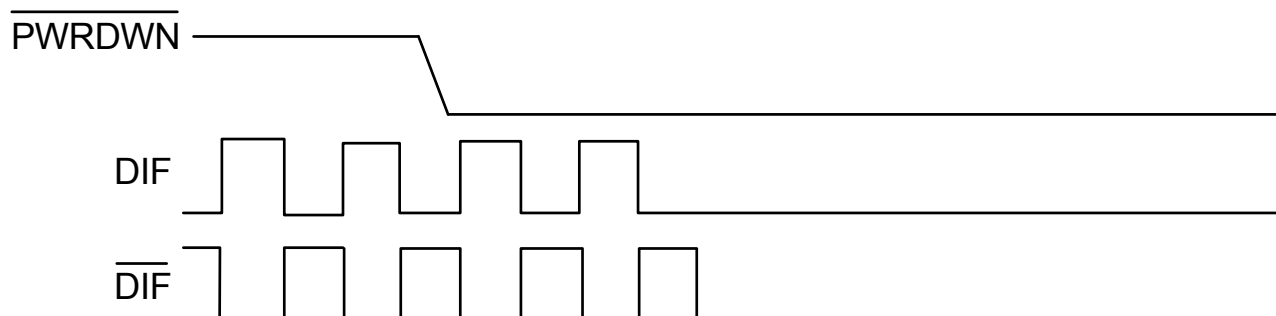

Figure 1. $\overline{\text{PWRDN}}$ Assertion

2.4.2. CKPWRGD Assertion

The powerup latency is to be less than 1.8 ms. This is the time from a valid CLK_IN input clock and the assertion of the PWRGD signal to the time that stable clocks are output from the device (PLL locked). All differential outputs stopped in a LOW/LOW condition resulting from power down must be driven high in less than 300 μ s of PWRDN deassertion to a voltage greater than 200 mV.

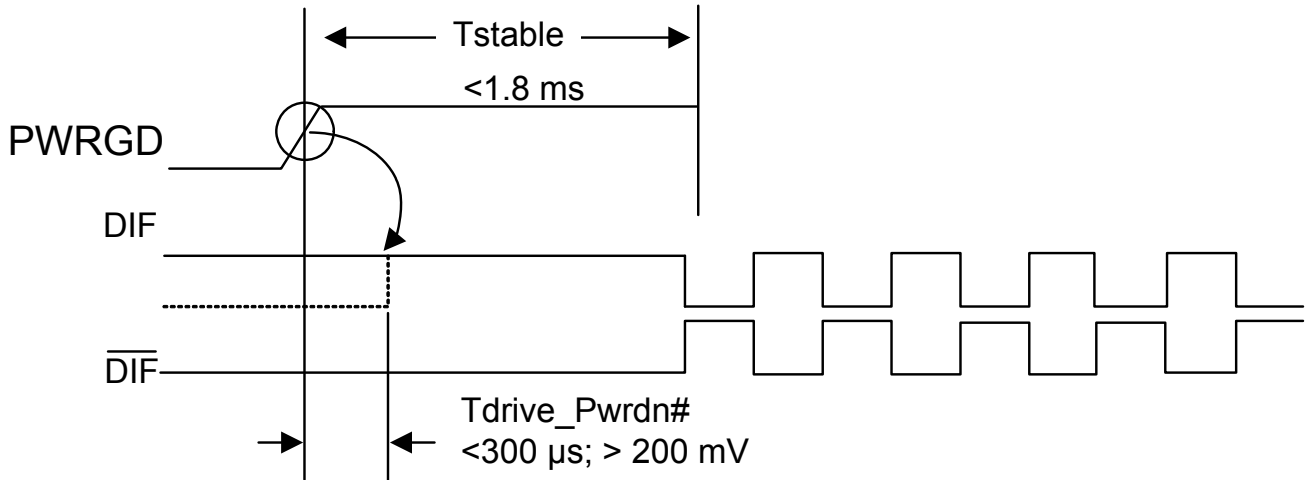

Figure 2. PWRDG Assertion (Pwrdown—Deassertion)

2.5. HBW_BYPASS_LBW

The HBW_BYPASS_LBW pin is a tri-level function input pin (refer to Table 1 for VIL_Tri, VIM_Tri, and VIH_Tri signal levels). It is used to select between PLL high-bandwidth, PLL bypass mode, or PLL low-bandwidth mode. In PLL bypass mode, the input clock is passed directly to the output stage, which may result in up to 50 ps of additive cycle-to-cycle jitter (50 ps + input jitter) on the differential outputs. In PLL mode, the input clock is passed through a PLL to reduce high-frequency jitter. The PLL HBW, BYPASS, and PLL LBW modes may be selected by asserting the HBW_BYPASS_LBW input pin to the appropriate level described in Table 14.

Table 14. PLL Bandwidth and Readback Table

HBW_BYPASS_LBW Pin	Mode	Byte 0, Bit 7	Byte 0, Bit 6
L	LBW	0	0
M	BYPASS	0	1
H	HBW	1	1

The Si53119 has the ability to override the latch value of the PLL operating mode from hardware strap pin 5 via the use of Byte 0 and bits 2 and 1. Byte 0 bit 3 must be set to 1 to allow the user to change Bits 2 and 1, affecting the PLL. Bits 7 and 6 will always read back the original latched value. A warm reset of the system will have to be accomplished if the user changes these bits.

2.6. Miscellaneous Requirements

Data Transfer Rate: 100 kbps (standard mode) is the base functionality required. Fast mode (400 kbps) functionality is optional.

Logic Levels: SMBus logic levels are based on a percentage of V_{DD} for the controller and other devices on the bus. Assume all devices are based on a 3.3 V supply.

Clock Stretching: The clock buffer must not hold/stretch the SCL or SDA lines low for more than 10 ms. Clock stretching is discouraged and should only be used as a last resort. Stretching the clock/data lines for longer than this time puts the device in an error/time-out mode and may not be supported in all platforms. It is assumed that all data transfers can be completed as specified without the use of clock/data stretching.

General Call: It is assumed that the clock buffer will not have to respond to the “general call.”

Electrical Characteristics: All electrical characteristics must meet the standard mode specifications found in Section 3 of the SMBus 2.0 specification.

Pull-Up Resistors: Any internal resistor pull-ups on the SDATA and SCLK inputs must be stated in the individual datasheet. The use of internal pull-ups on these pins of below 100 K is discouraged. Assume that the board designer will use a single external pull-up resistor for each line and that these values are in the 5–6 k Ω range. Assume one SMBus device per DIMM (serial presence detect), one SMBus controller, one clock buffer, one clock driver plus one/two more SMBus devices on the platform for capacitive loading purposes.

Input Glitch Filters: Only fast mode SMBus devices require input glitch filters to suppress bus noise. The clock buffer is specified as a standard mode device and is not required to support this feature. However, it is considered a good design practice to include the filters.

PWRDN: If a clock buffer is placed in $\overline{\text{PWRDN}}$ mode, the SDATA and SCLK inputs must be Tri-stated and the device must retain all programming information. I_{DD} current due to the SMBus circuitry must be characterized and in the data sheet.

3. Test and Measurement Setup

3.1. Input Edge

Input edge rate is based on single-ended measurement. This is the minimum input edge rate at which the Si53119 is guaranteed to meet all performance specifications.

Table 15. Input Edge Rate

Frequency	Min	Max	Unit
100 MHz	0.35	N/A	V/ns
133 MHz	0.35	N/A	V/ns

3.1.1. Measurement Points for Differential

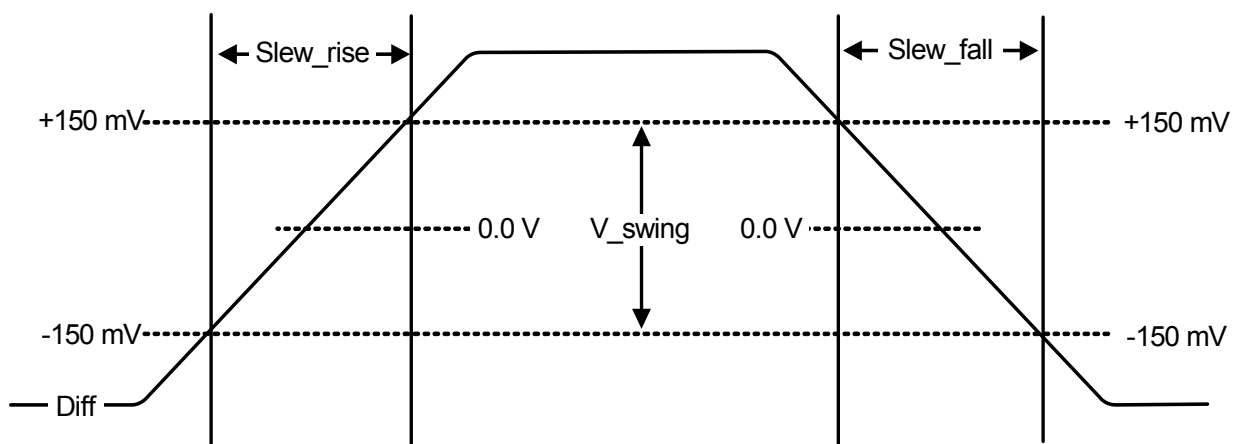

Figure 3. Measurement Points for Rise Time and Fall Time

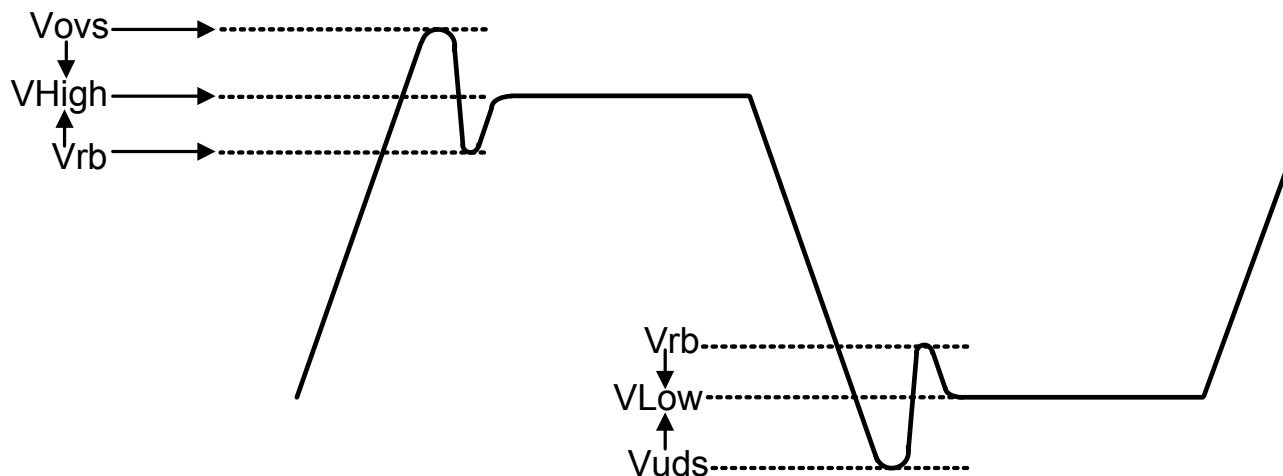

Figure 4. Single-Ended Measurement Points for V_{OVS} , V_{uds} , V_{rb}

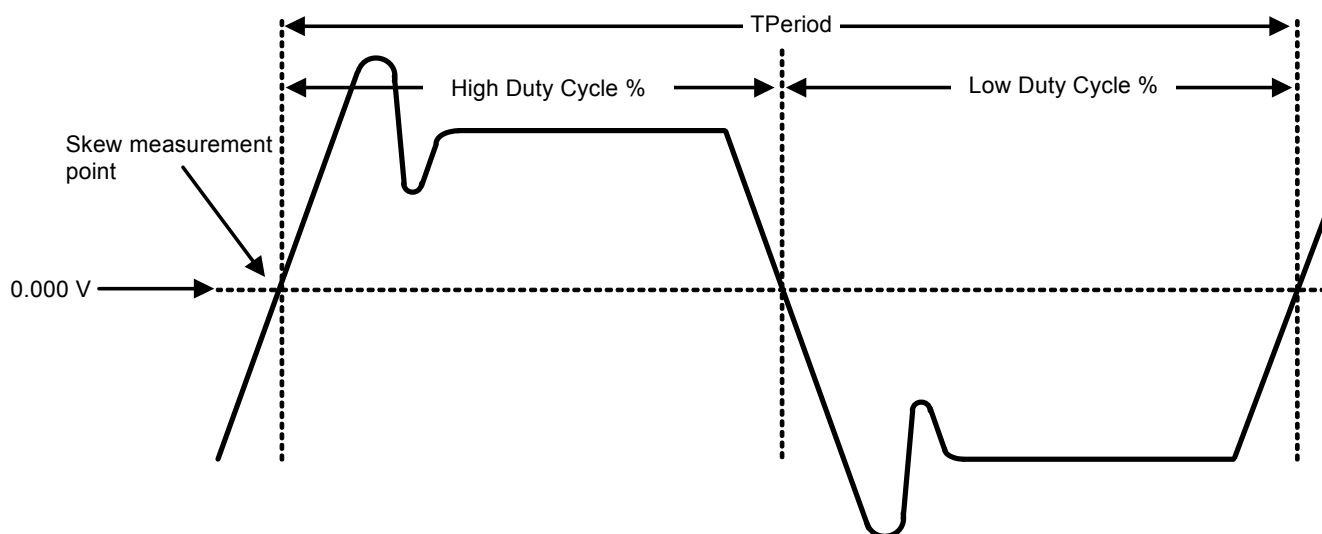

Figure 5. Differential (CLOCK-CLOCK) Measurement Points (T_{period} , Duty Cycle, Jitter)

3.2. Termination of Differential Outputs

All differential outputs are to be tested into a $100\ \Omega$ or $85\ \Omega$ differential impedance transmission line. Source terminated clocks have some inherent limitations as to the maximum trace length and frequencies that can be supported. For CPU outputs, a maximum trace length of 10" and a maximum of 200 MHz are assumed. For SRC clocks, a maximum trace length of 16" and maximum frequency of 100 MHz is assumed. For frequencies beyond 200 MHz, trace lengths must be restricted to avoid signal integrity problems.

Table 16. Differential Output Termination

Clock	Board Trace Impedance	R_s	R_p	Unit
DIFF Clocks— $50\ \Omega$ configuration	100	$33\pm 5\%$	N/A	Ω
DIFF Clocks— $43\ \Omega$ configuration	85	$27\pm 5\%$	N/A	Ω

3.2.1. Termination of Differential NMOS Push-Pull Type Outputs

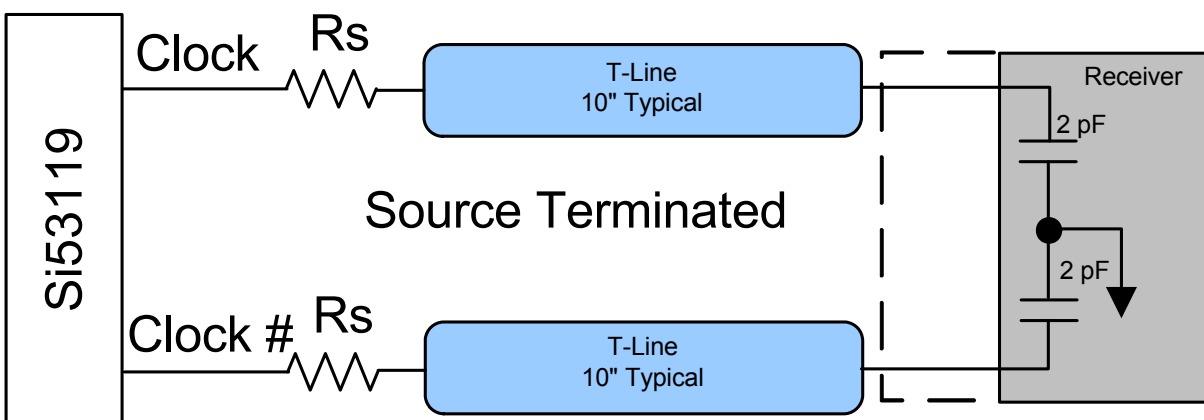

Figure 6. 0.7 V Configuration Test Load Board Termination for NMOS Push-Pull

4. Control Registers

4.1. Byte Read/Write

Reading or writing a register in an SMBus slave device in byte mode always involves specifying the register number.

4.1.1. Byte Read

The standard byte read is as shown in Figure 7. It is an extension of the byte write. The write start condition is repeated; then, the slave device starts sending data, and the master acknowledges it until the last byte is sent. The master terminates the transfer with a NAK, then a stop condition. For byte operation, the 2 x 7th bit of the command byte must be set. For block operations, the 2 x 7th bit must be reset. If the bit is not set, the next byte must be the byte transfer count.

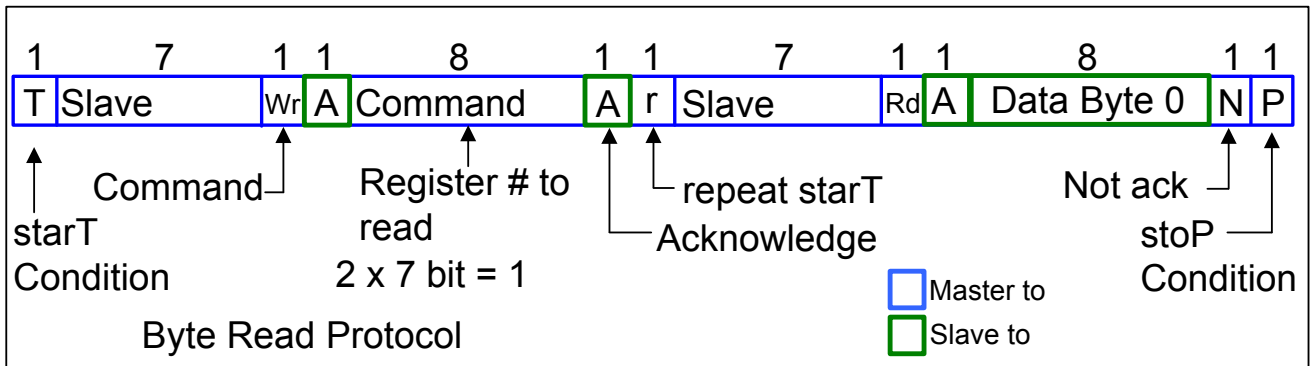

Figure 7. Byte Read Protocol

4.1.2. Byte Write

Figure 8 illustrates a simple, typical byte write. For byte operation, the 2 x 7th bit of the command byte must be set. For block operations, the 2 x 7th bit must be reset. If the bit is not set, the next byte must be the byte transfer count. The count can be between 1 and 32. It is not allowed to be zero or to exceed 32.

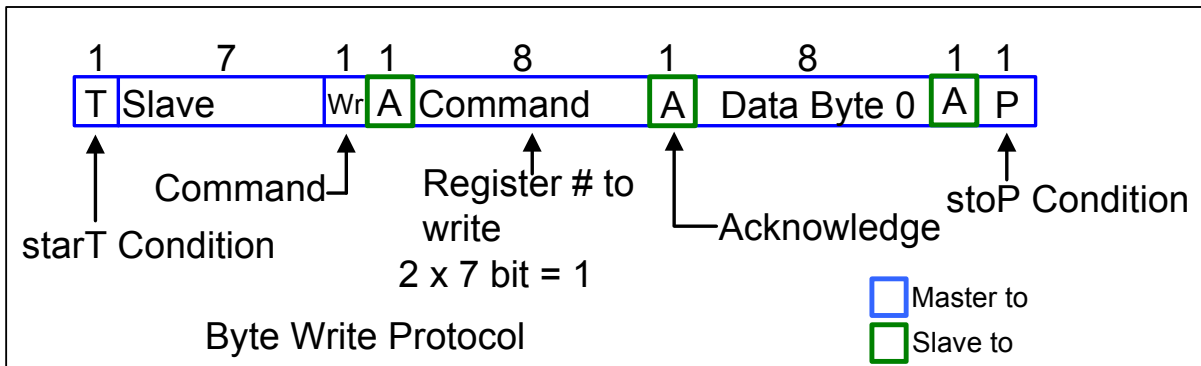

Figure 8. Byte Write Protocol

4.2. Block Read/Write

4.2.1. Block Read

After the slave address is sent with the R/W condition bit set, the command byte is sent with the MSB = 0. The slave acknowledges the register index in the command byte. The master sends a repeat start function. After the slave acknowledges this, the slave sends the number of bytes it wants to transfer (>0 and <33). The master acknowledges each byte except the last and sends a stop function.

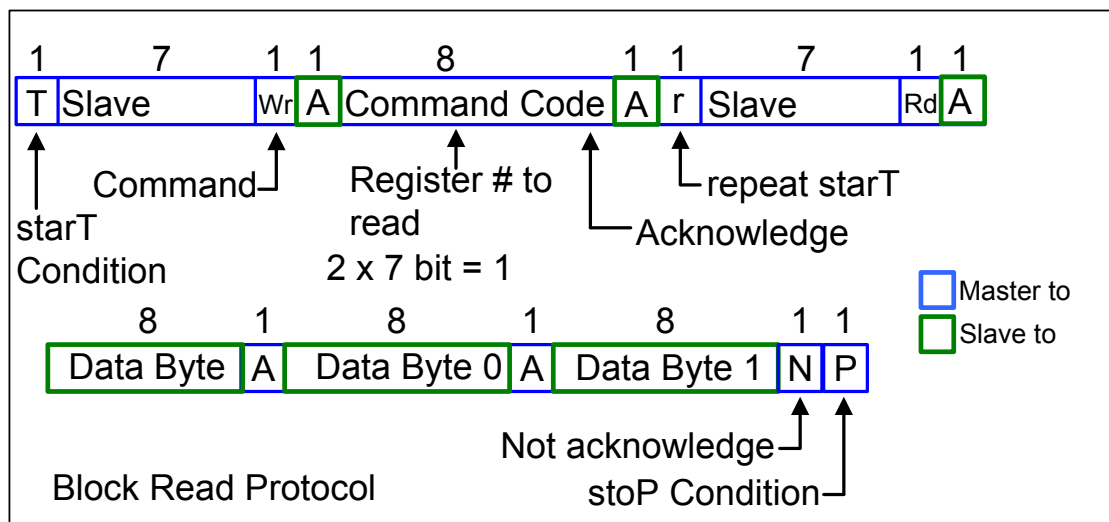

Figure 9. Block Read Protocol

4.2.2. Block Write

After the slave address is sent with the R/W condition bit not set, the command byte is sent with the MSB = 0. The lower seven bits indicate the register at which to start the transfer. If the command byte is 00h, the slave device will be compatible with existing block mode slave devices. The next byte of a write must be the count of bytes that the master will transfer to the slave device. The byte count must be greater than zero and less than 33. Following this byte are the data bytes to be transferred to the slave device. The slave device always acknowledges each byte received. The transfer is terminated after the slave sends the ACK and the master sends a stop function.

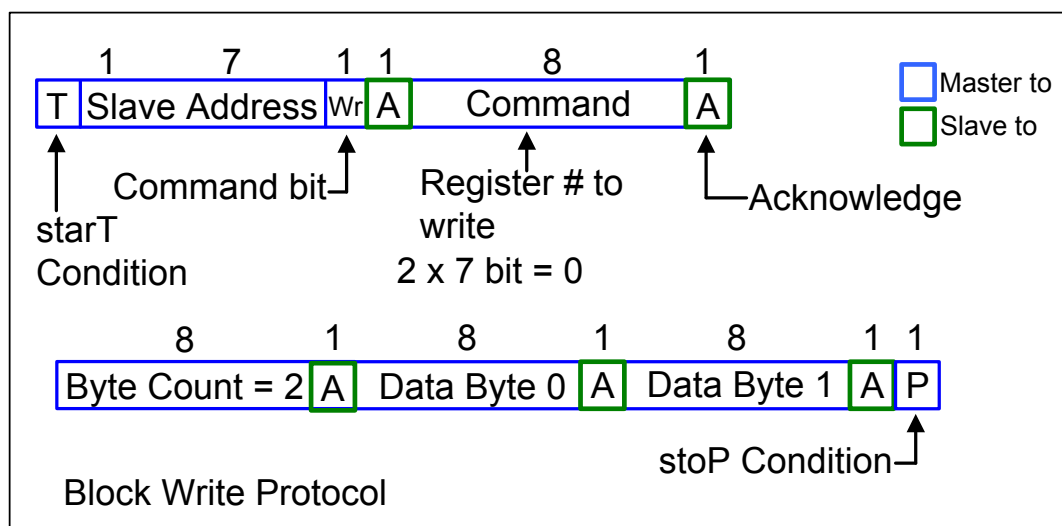

Figure 10. Block Write Protocol

4.3. Control Registers

Table 17. Byte 0: Frequency Select, Output Enable, PLL Mode Control Register

Bit	Description	If Bit = 0	If Bit = 1	Type	Default	Output(s) Affected
0	100M_133M# Frequency Select	133 MHz	100 MHz	R	Latched at power up	DIF[11:0]
1	Reserved				0	
2	Reserved				0	
3	Output Enable DIF 16	Low/Low	Enable	RW	1	DIF_16
4	Output Enable DIF 17	Low/Low	Enable	RW	1	DIF_17
5	Output Enable DIF 18	Low/Low	Enable	RW	1	DIF_18
6	PLL Mode 0	See PLL Operating Mode Readback Table		R	Latched at power up	
7	PLL Mode 1	See PLL Operating Mode Readback Table		R	Latched at power up	

Table 18. Byte 1: Output Enable Control Register

Bit	Description	If Bit = 0	If Bit = 1	Type	Default	Output(s) Affected
0	Output Enable DIF 0	Low/Low	Enabled	RW	1	DIF[0]
1	Output Enable DIF 1	Low/Low	Enabled	RW	1	DIF[1]
2	Output Enable DIF 2	Low/Low	Enabled	RW	1	DIF[2]
3	Output Enable DIF 3	Low/Low	Enabled	RW	1	DIF[3]
4	Output Enable DIF 4	Low/Low	Enabled	RW	1	DIF[4]
5	Output Enable DIF 5	Low/Low	Enabled	RW	1	DIF[5]
6	Output Enable DIF 6	Low/Low	Enabled	RW	1	DIF[6]
7	Output Enable DIF 7	Low/Low	Enabled	RW	1	DIF[7]

Table 19. Byte 2: Output Enable Control Register

Bit	Description	If Bit = 0	If Bit = 1	Type	Default	Output(s) Affected
0	Output Enable DIF 8	Low/Low	Enabled	RW	1	DIF[8]
1	Output Enable DIF 9	Low/Low	Enabled	RW	1	DIF[9]
2	Output Enable DIF 10	Low/Low	Enabled	RW	1	DIF[10]
3	Output Enable DIF 11	Low/Low	Enabled	RW	1	DIF[11]
4	Output Enable DIF 12	Low/Low	Enabled	RW	1	DIF[12]
5	Output Enable DIF 13	Low/Low	Enabled	RW	1	DIF[14]
6	Output Enable DIF 14	Low/Low	Enabled	RW	1	DIF[15]
7	Output Enable DIF 15	Low/Low	Enabled	RW	1	DIF[16]

Table 20. Byte 3: Reserved Control Register

Bit	Description	If Bit = 0	If Bit = 1	Type	Default	Output(s) Affected
0	Reserved				0	
1	Reserved				0	
2	Reserved				0	
3	Reserved				0	
4	Reserved				0	
5	Reserved				0	
6	Reserved				0	
7	Reserved				0	

Table 21. Byte 4: Reserved Control Register

Bit	Description	If Bit = 0	If Bit = 1	Type	Default	Output(s) Affected
0	Reserved				0	
1	Reserved				0	
2	Reserved				0	
3	Reserved				0	
4	Reserved				0	
5	Reserved				0	
6	Reserved				0	
7	Reserved				0	

Table 22. Byte 5: Vendor/Revision Identification Control Register

Bit	Description	If Bit = 0	If Bit = 1	Type	Default	Output(s) Affected
0	Vendor ID Bit 0			R	Vendor Specific	0
1	Vendor ID Bit 1			R	Vendor Specific	0
2	Vendor ID Bit 2			R	Vendor Specific	0
3	Vendor ID Bit 3			R	Vendor Specific	1
4	Revision Code Bit 0			R	Vendor Specific	0
5	Revision Code Bit 1			R	Vendor Specific	0
6	Revision Code Bit 2			R	Vendor Specific	0
7	Revision Code Bit 3			R	Vendor Specific	0

Table 23. Byte 6: Device ID Control Register

Bit	Description	If Bit = 0	If Bit = 1	Type	Default	Output(s) Affected
0	Device ID 0			R	0	
1	Device ID 1			R	1	
2	Device ID 2			R	1	
3	Device ID 3			R	1	
4	Device ID 4			R	0	
5	Device ID 5			R	1	
6	Device ID 6			R	1	
7	Device ID 7 (MSB)			R	1	

Table 24. Byte 7: Byte Count Register

Bit	Description	If Bit = 0	If Bit = 1	Type	Default	Output(s) Affected
0	BC0 - Writing to this register configures how many bytes will be read back			RW	0	
1	BC1 -Writing to this register configures how many bytes will be read back			RW	0	
2	BC2 -Writing to this register configures how many bytes will be read back			RW	0	
3	BC3 -Writing to this register configures how many bytes will be read back			RW	1	
4	BC4 -Writing to this register configures how many bytes will be read back			RW	0	
5	Reserved				0	
6	Reserved				0	
7	Reserved				0	

5. Pin Descriptions: 72-Pin QFN

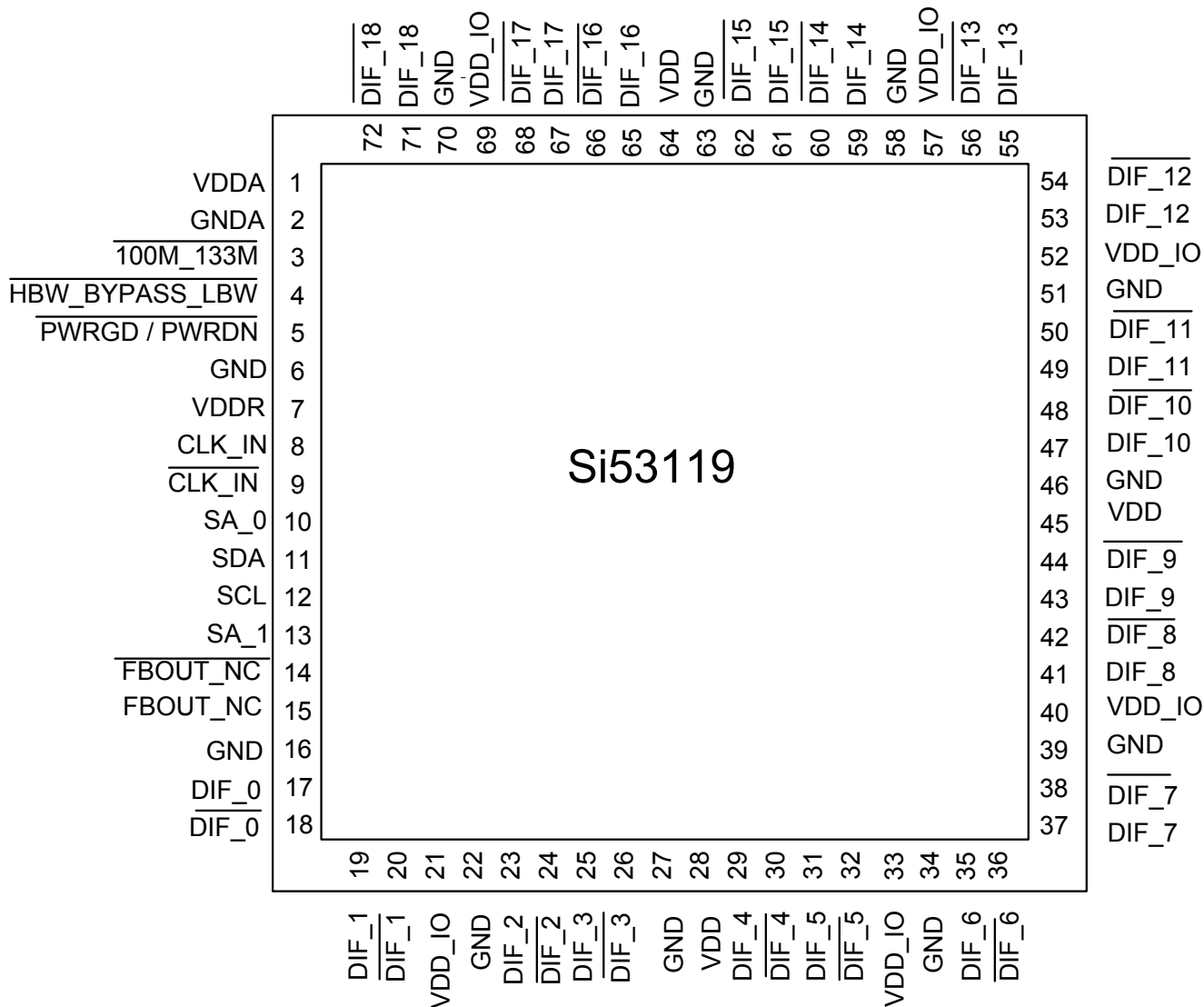

Table 25. Si53119 72-Pin QFN Descriptions

Pin #	Name	Type	Description
1	VDDA	3.3 V	3.3 V power supply for PLL.
2	GND	GND	Ground for PLL.
3	$\overline{100M_133M}$	I,SE	3.3 V tolerant inputs for input/output frequency selection. An external pull-up or pull-down resistor is attached to this pin to select the input/output frequency. High = 100 MHz output Low = 133 MHz output
4	$\overline{HBW_BYPASS_LBW}$	I, SE	Tri-Level input for selecting the PLL bandwidth or bypass mode. High = High BW mode Med = Bypass mode Low = Low BW mode
5	$\overline{PWRGD/PWRDN}$	I	3.3 V LVTTTL input to power up or power down the device.
6	GND	GND	Ground for outputs.
7	VDDR	VDD	3.3 V power supply for differential input receiver. This VDDR should be treated as an analog power rail and filtered appropriately.
8	CLK_IN	I, DIF	0.7 V Differential input.
9	$\overline{CLK_IN}$	I, DIF	0.7 V Differential input.
10	SA_0	I,PU	3.3 V LVTTTL input selecting the address. Tri-level input.
11	SDA	I/O	Open collector SMBus data.
12	SCL	I/O	SMBus slave clock input.
13	SA_1	I,PU	3.3 V LVTTTL input selecting the address. Tri-level input.
14	$\overline{FBOUT / NC}$	I/O	Complementary differential feedback output. Do not connect this pin to anything.
15	FBOUT / NC	I/O	True differential feedback output. Do not connect this pin to anything.
16	GND	GND	Ground for outputs.
17	DIF_0	O, DIF	0.7 V Differential clock outputs. Default is 1:1.
18	$\overline{DIF_0}$	O, DIF	0.7 V Differential clock outputs. Default is 1:1.
19	DIF_1	O, DIF	0.7 V Differential clock outputs. Default is 1:1.
20	$\overline{DIF_1}$	O, DIF	0.7 V Differential clock outputs. Default is 1:1.
21	VDD_IO	VDD	Power supply for differential outputs.
22	GND	GND	Ground for outputs.
23	DIF_2	O, DIF	0.7 V Differential clock outputs. Default is 1:1.
24	$\overline{DIF_2}$	O, DIF	0.7 V Differential clock outputs. Default is 1:1.

Table 25. Si53119 72-Pin QFN Descriptions (Continued)

Pin #	Name	Type	Description
25	DIF_3	O, DIF	0.7 V Differential clock outputs. Default is 1:1.
26	$\overline{\text{DIF}}_3$	O, DIF	0.7 V Differential clock outputs. Default is 1:1.
27	GND	GND	Ground for outputs.
28	VDD	3.3 V	3.3 V power supply for outputs.
29	DIF_4	O, DIF	0.7 V Differential clock outputs. Default is 1:1.
30	$\overline{\text{DIF}}_4$	O, DIF	0.7 V Differential clock outputs. Default is 1:1.
31	DIF_5	O, DIF	0.7 V Differential clock outputs. Default is 1:1.
32	$\overline{\text{DIF}}_5$	O, DIF	0.7 V Differential clock outputs. Default is 1:1.
33	VDD_IO	VDD	Power supply for differential outputs.
34	GND	GND	Ground for outputs.
35	DIF_6	O, DIF	0.7 V Differential clock outputs. Default is 1:1.
36	$\overline{\text{DIF}}_6$	O, DIF	0.7 V Differential clock outputs. Default is 1:1.
37	DIF_7	O, DIF	0.7 V Differential clock outputs. Default is 1:1.
38	$\overline{\text{DIF}}_7$	O, DIF	0.7 V Differential clock outputs. Default is 1:1.
39	GND	GND	Ground for outputs.
40	VDD_IO	VDD	Power supply for differential outputs.
41	DIF_8	O, DIF	0.7 V Differential clock outputs. Default is 1:1.
42	$\overline{\text{DIF}}_8$	O, DIF	0.7 V Differential clock outputs. Default is 1:1.
43	DIF_9	O, DIF	0.7 V Differential clock outputs. Default is 1:1.
44	$\overline{\text{DIF}}_9$	O, DIF	0.7 V Differential clock outputs. Default is 1:1.
45	VDD	3.3 V	3.3 V power supply for outputs.
46	GND	GND	Ground for outputs.
47	DIF_10	O, DIF	0.7 V Differential clock outputs. Default is 1:1.
48	$\overline{\text{DIF}}_{10}$	O, DIF	0.7 V Differential clock outputs. Default is 1:1.
49	DIF_11	O, DIF	0.7 V Differential clock outputs. Default is 1:1.
50	$\overline{\text{DIF}}_{11}$	O, DIF	0.7 V Differential clock outputs. Default is 1:1.
51	GND	GND	Ground for outputs.
52	VDD_IO	VDD	Power supply for differential outputs.
53	DIF_12	O, DIF	0.7 V Differential clock outputs. Default is 1:1.

Table 25. Si53119 72-Pin QFN Descriptions (Continued)

Pin #	Name	Type	Description
54	$\overline{\text{DIF}}_{12}$	O, DIF	0.7 V Differential clock outputs. Default is 1:1.
55	DIF_13	O, DIF	0.7 V Differential clock outputs. Default is 1:1.
56	$\overline{\text{DIF}}_{13}$	O, DIF	0.7 V Differential clock outputs. Default is 1:1.
57	VDD_IO	VDD	Power supply for differential outputs.
58	GND	GND	Ground for outputs.
59	DIF_14	O, DIF	0.7 V Differential clock outputs. Default is 1:1.
60	$\overline{\text{DIF}}_{14}$	O, DIF	0.7 V Differential clock outputs. Default is 1:1.
61	DIF_15	O, DIF	0.7 V Differential clock outputs. Default is 1:1.
62	$\overline{\text{DIF}}_{15}$	O, DIF	0.7 V Differential clock outputs. Default is 1:1.
63	GND	GND	Ground for outputs.
64	VDD	3.3 V	3.3 V power supply for outputs.
65	DIF_16	O, DIF	0.7 V Differential clock outputs. Default is 1:1.
66	$\overline{\text{DIF}}_{16}$	O, DIF	0.7 V Differential clock outputs. Default is 1:1.
67	DIF_17	O, DIF	0.7 V Differential clock outputs. Default is 1:1.
68	$\overline{\text{DIF}}_{17}$	O, DIF	0.7 V Differential clock outputs. Default is 1:1.
69	VDD_IO	VDD	Power supply for differential outputs.
70	GND	GND	Ground for outputs.
71	DIF_18	O, DIF	0.7 V Differential clock outputs. Default is 1:1.
72	$\overline{\text{DIF}}_{18}$	O, DIF	0.7 V Differential clock outputs. Default is 1:1.
73	GND	GND	Ground for outputs.

6. Power Filtering Example

6.1. Ferrite Bead Power Filtering

Recommended ferrite bead filtering equivalent to the following: 600 Ω impedance at 100 MHz, $\leq 0.1 \Omega$ DCR max., ≥ 400 mA current rating.

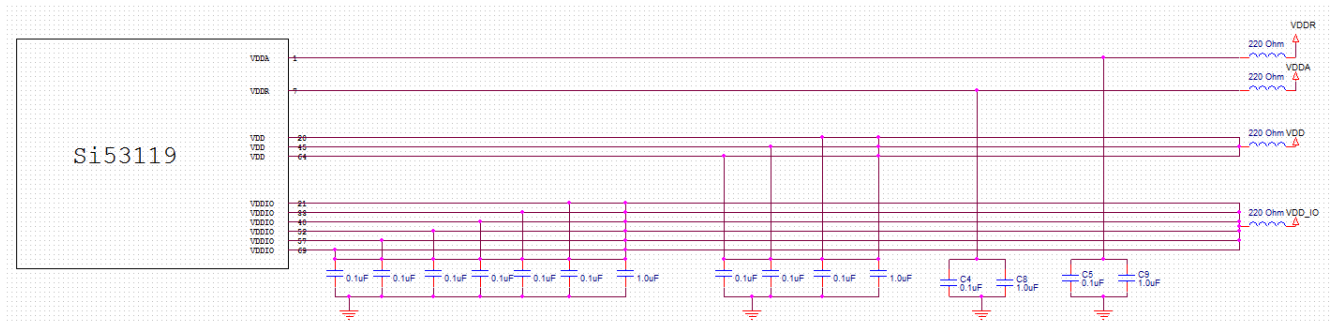

Figure 11. Schematic Example of the Si53119 Power Filtering

Si53119

7. Ordering Guide

Part Number	Package Type	Temperature
Lead-free		
Si53119-A01AGM	72-pin QFN	Extended, -40 to 85 °C
Si53119-A01AGMR	72-pin QFN—Tape and Reel	Extended, -40 to 85 °C

8. Package Outline

Figure 12 illustrates the package details for the Si53119. Table 26 lists the values for the dimensions shown in the illustration.

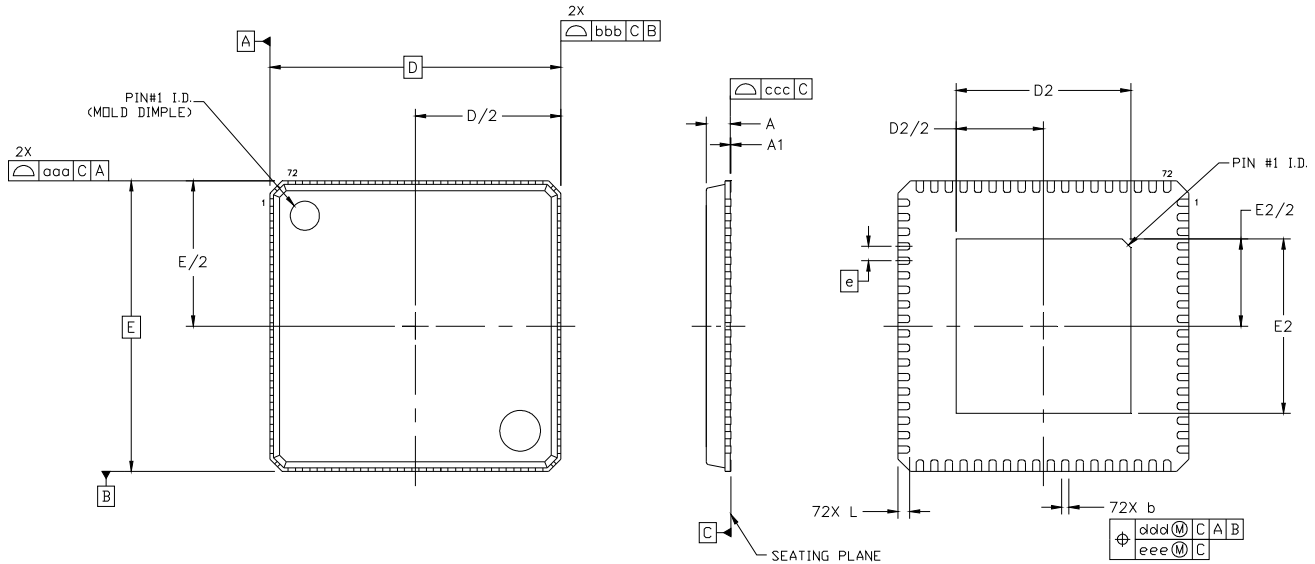

Figure 12. 72-Pin Quad Flat No Lead (QFN) Package

Table 26. Package Dimensions

Dimension	Min	Nom	Max	Dimension	Min	Nom	Max
A	0.80	0.85	0.90	E2	5.90	6.00	6.10
A1	0.00	0.02	0.05	L	0.30	0.40	0.50
b	0.18	0.25	0.30	aaa	0.10		
D	10.00 BSC.			bbb	0.10		
D2	5.90	6.00	6.10	ccc	0.08		
e	0.50 BSC.			ddd	0.10		
E	10.00 BSC.			eee	0.05		

Notes:

1. All dimensions shown are in millimeters (mm) unless otherwise noted.
2. Dimensioning and Tolerancing per ANSI Y14.5M-1994.
3. This drawing conforms to JEDEC outline MO-220
4. Recommended card reflow profile is per the JEDEC/IPC J-STD-020 specification for Small Body Components.

9. Land Pattern: 72-pin QFN

Figure 13 shows the recommended land pattern details for the Si53119 in a 72-pin QFN package. Table 27 lists the values for the dimensions shown in the illustration.

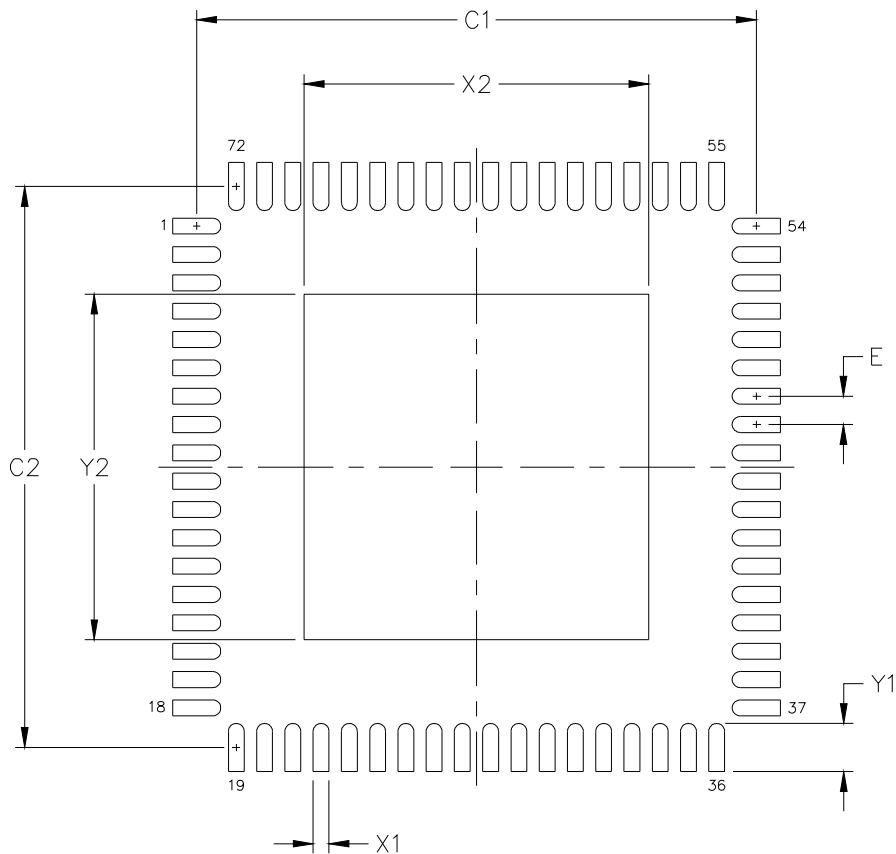

Figure 13. 72-pin QFN Land Pattern

Table 27. PCB Land Pattern Dimensions

Dimension	mm
C1	9.90
C2	9.90
E	0.50
X1	0.30
Y1	0.85
X2	6.10
Y2	6.10

CONTACT INFORMATION

Silicon Laboratories Inc.

400 West Cesar Chavez
Austin, TX 78701
Tel: 1+(512) 416-8500
Fax: 1+(512) 416-9669
Toll Free: 1+(877) 444-3032

Please visit the Silicon Labs Technical Support web page:

<https://www.silabs.com/support/pages/contacttechnicalsupport.aspx>
and register to submit a technical support request.

Patent Notice

Silicon Labs invests in research and development to help our customers differentiate in the market with innovative low-power, small size, analog-intensive mixed-signal solutions. Silicon Labs' extensive patent portfolio is a testament to our unique approach and world-class engineering team.

The information in this document is believed to be accurate in all respects at the time of publication but is subject to change without notice. Silicon Laboratories assumes no responsibility for errors and omissions, and disclaims responsibility for any consequences resulting from the use of information included herein. Additionally, Silicon Laboratories assumes no responsibility for the functioning of undescribed features or parameters. Silicon Laboratories reserves the right to make changes without further notice. Silicon Laboratories makes no warranty, representation or guarantee regarding the suitability of its products for any particular purpose, nor does Silicon Laboratories assume any liability arising out of the application or use of any product or circuit, and specifically disclaims any and all liability, including without limitation consequential or incidental damages. Silicon Laboratories products are not designed, intended, or authorized for use in applications intended to support or sustain life, or for any other application in which the failure of the Silicon Laboratories product could create a situation where personal injury or death may occur. Should Buyer purchase or use Silicon Laboratories products for any such unintended or unauthorized application, Buyer shall indemnify and hold Silicon Laboratories harmless against all claims and damages.

Silicon Laboratories and Silicon Labs are trademarks of Silicon Laboratories Inc.
Other products or brandnames mentioned herein are trademarks or registered trademarks of their respective holders.

Данный компонент на территории Российской Федерации

Вы можете приобрести в компании MosChip.

Для оперативного оформления запроса Вам необходимо перейти по данной ссылке:

<http://moschip.ru/get-element>

Вы можете разместить у нас заказ для любого Вашего проекта, будь то серийное производство или разработка единичного прибора.

В нашем ассортименте представлены ведущие мировые производители активных и пассивных электронных компонентов.

Нашей специализацией является поставка электронной компонентной базы двойного назначения, продукции таких производителей как XILINX, Intel (ex.ALTERA), Vicor, Microchip, Texas Instruments, Analog Devices, Mini-Circuits, Amphenol, Glenair.

Сотрудничество с глобальными дистрибьюторами электронных компонентов, предоставляет возможность заказывать и получать с международных складов практически любой перечень компонентов в оптимальные для Вас сроки.

На всех этапах разработки и производства наши партнеры могут получить квалифицированную поддержку опытных инженеров.

Система менеджмента качества компании отвечает требованиям в соответствии с ГОСТ Р ИСО 9001, ГОСТ РВ 0015-002 и ЭС РД 009

Офис по работе с юридическими лицами:

105318, г.Москва, ул.Щербаковская д.3, офис 1107, 1118, ДЦ «Щербаковский»

Телефон: +7 495 668-12-70 (многоканальный)

Факс: +7 495 668-12-70 (доб.304)

E-mail: info@moschip.ru

Skype отдела продаж:

moschip.ru

moschip.ru_4

moschip.ru_6

moschip.ru_9