

### Features

- Capable of Driving 10 or more WLEDs
- Chip Enable with Soft-start
- Analog and PWM Dimming
- Peak Efficiency up to 90%
- Low Quiescent Current
- Fixed Frequency of 1MHz
- Over Current Protection
- Over Voltage Protection
- Thermal Protection
- UVLO
- Tiny Pb-Free Packages (RoHS Compliant): MSOP-8 and DFN 2X2

### Description

The PAM2841 is a white LED driver, capable of driving 10 or more WLEDs in series (depending on forward voltage of the LEDs) with a range of input voltages from 2.7V to 5.5V.

The PAM2841 features over current protection, over voltage protection, under voltage lockout and over temperature protection, which prevent the device from damage.

LED dimming can be done by four methods as described in the Application Information hereinafter.

### Applications

- WLED Driver System

### Typical Application

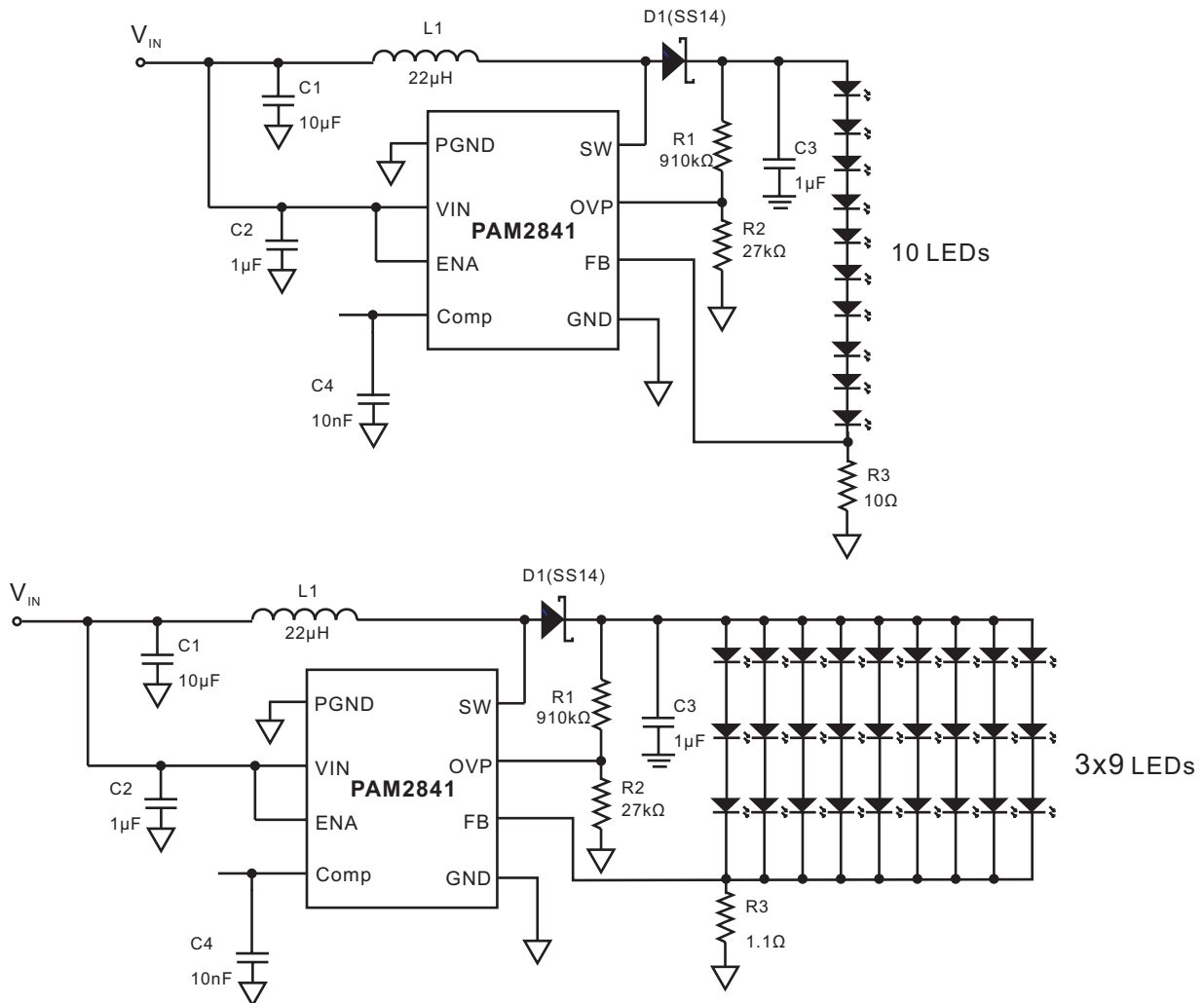

### Block Diagram

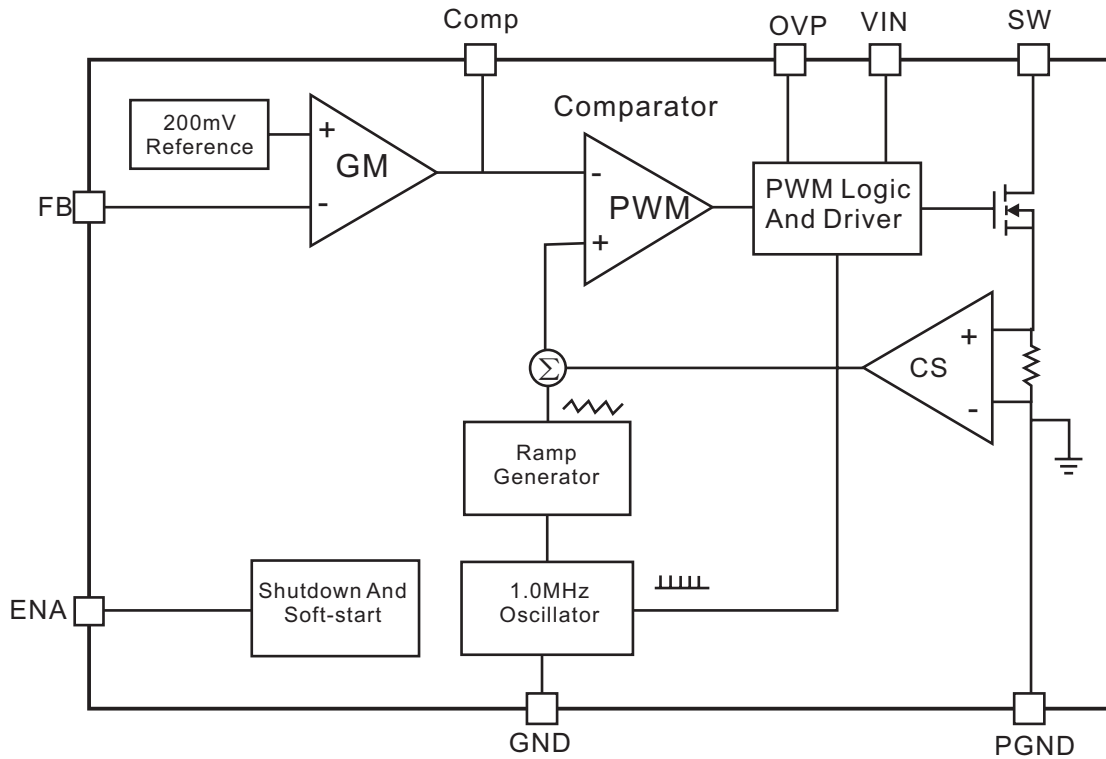

### Pin Configuration & Marking Information

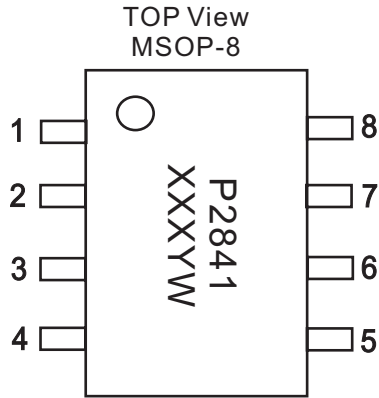

XXX: Internal Code  
Y: Year  
W: Weekly

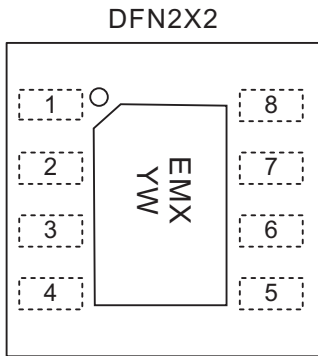

EM: Product Code  
X: Internal Code  
Y: Year  
W: Weekly

Pin number	Name	Description
1	PGND	Power Ground
2	VIN	Input Voltage
3	ENA	Chip Enable, Active High
4	Comp	Compensation Node
5	GND	Chip Ground
6	FB	Feedback
7	OVP	Over Voltage
8	SW	Drain of Main Switch.



### Absolute Maximum Ratings

These are stress ratings only and functional operation is not implied. Exposure to absolute maximum ratings for prolonged time periods may affect device reliability. All voltages are with respect to ground.

Supply Voltage.....	6.0V	Storage Temperature.....	-40°C to 150°C
Output Current.....	50mA	Maximum Junction Temperature.....	150°C
I/O Pin Voltage Range.....	GND-0.3V to V <sub>DD</sub> +0.3V	Soldering Temperature.....	300°C, 5sec
Maximum SW Pin Voltage.....	40V		

### Recommended Operating Conditions

Supply Voltage Range.....	2.8V to 5.5V	Junction Temperature Range.....	0°C to 125°C
Operation Temperature Range.....	-40°C to 85°C		

### Thermal Information

Parameter	Symbol	Package	Maximum	Unit
Thermal Resistance (Junction to Ambient)	$\theta_{JA}$	MSOP	180	°C/W
		DFN	102	°C/W
Thermal Resistance (Junction to Case)	$\theta_{JC}$	MSOP	40	°C/W
		DFN	20	°C/W

### Electrical Characteristic

V<sub>EN</sub>=V<sub>DD</sub>=5.0V, 10 LEDs, T<sub>A</sub>=25°C, unless otherwise noted.

Parameters	Symbol	Test Conditions	MIN.	TYP.	MAX.	UNITS
Supply Voltage Range	V <sub>DD</sub>		2.7		5.5	V
Quiescent Current	I <sub>Q</sub>	No Switching		200	300	μA
Shutdown Current	I <sub>SD</sub>	V <sub>ENA</sub> =low			1	μA
Output Current	I <sub>o</sub>	R3=5.1Ω		40		mA
		R3=6.8Ω		30		
		R3=10Ω		20		
		R3=20Ω		10		
Output Voltage Range	V <sub>O</sub>		V <sub>IN</sub> ×1.1		40	V
Feedback Voltage	V <sub>FB</sub>	V <sub>ENA</sub> =high	194	200	206	mV
SW On Resistance	R <sub>DS(ON)</sub>	I <sub>SW</sub> =100mA		0.35	0.5	Ω
SW Current Limit	I <sub>LIM</sub>	Switch On		1.5		A
SW Frequency	f <sub>SW</sub>		0.7	1.0	1.3	MHz
Maximum Duty Cycle	DC			95		%
Over Voltage Protection Threshold	OVP	Open Load		1.2		V
Enable Threshold Voltage	V <sub>EL</sub>	Chip Shutdown			0.4	V
	V <sub>EH</sub>	Chip On	1.2			
Under Voltage Lockout	UVLO	V <sub>IN</sub> falling	2.0	2.2	2.4	V
UVLO Hysteresis	V <sub>TH</sub>			0.2		V
Over Temperature Shutdown	OTS			150		°C
Over Temperature Hysteresis	OTH			30		°C



# PAM2841

## 1.5A SW Current, 40V Precision WLED Driver

### Typical Operating Characteristics

$T_A=25^{\circ}\text{C}$ ,  $V_{DD}=5\text{V}$ , unless otherwise noted.

1. Efficiency VS Input Voltage

$I_{LED}=20\text{mA}$ ,  $L=22\mu\text{H}$

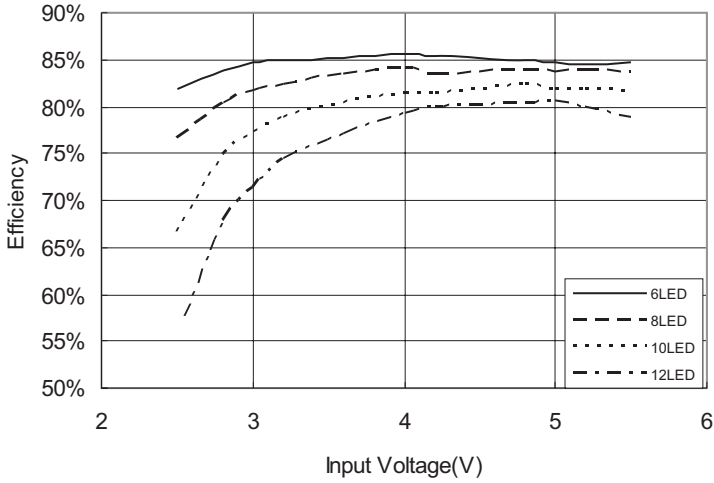

2. Efficiency VS Load Current

6 LED,  $L=22\mu\text{H}$

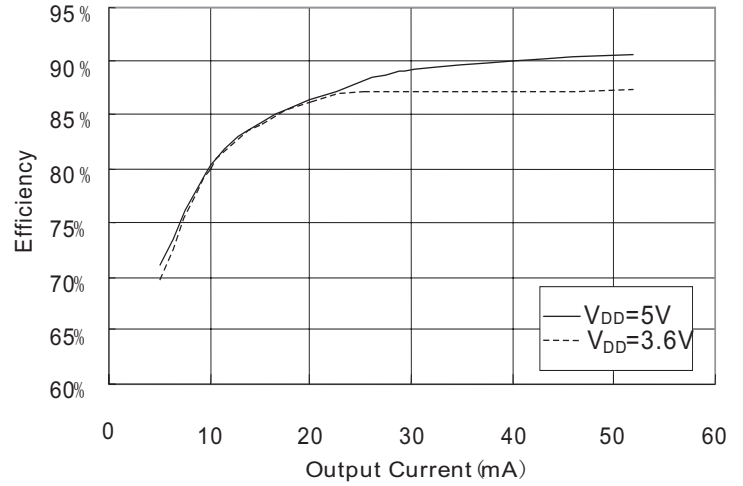

3. Efficiency VS Input Voltage

$I_{LED}=20\text{mA}$ , 10 LED

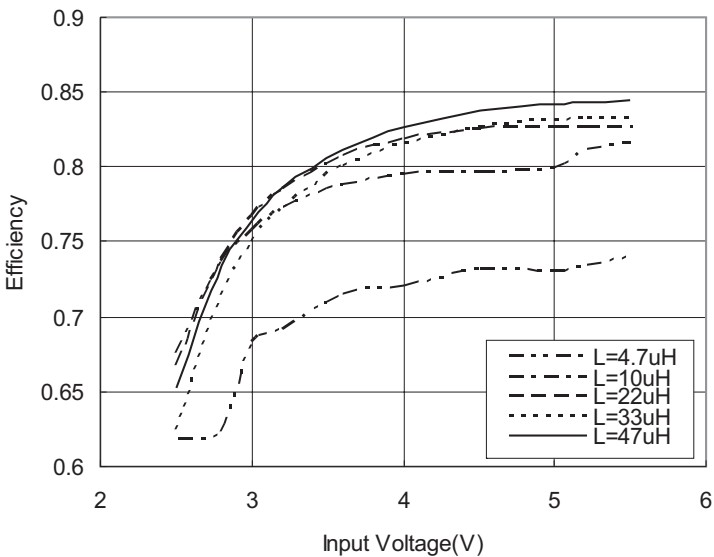

4. LED Current VS Output Voltage

$L=47\mu\text{H}$

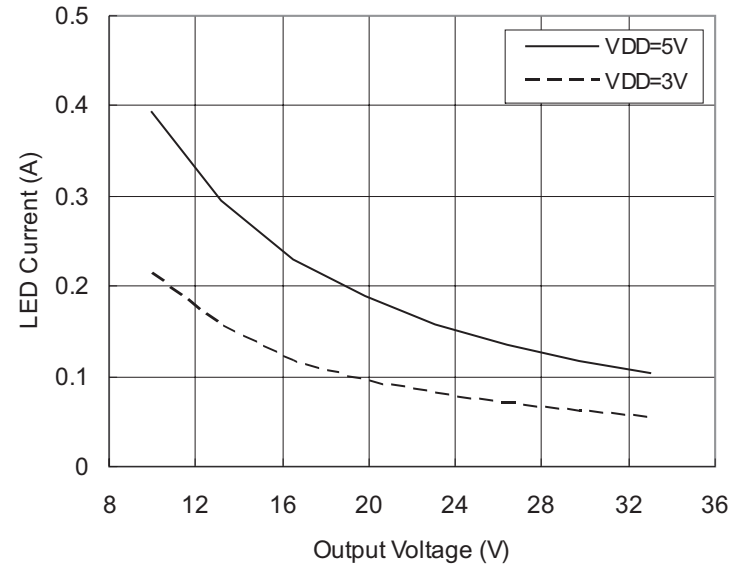

### Typical Operating Characteristics

$T_A=25^\circ\text{C}, V_{DD}=5\text{V}$ , unless otherwise noted.

5. Feedback Voltage VS Input voltage

10 LED,  $I_{LED}=20\text{mA}$

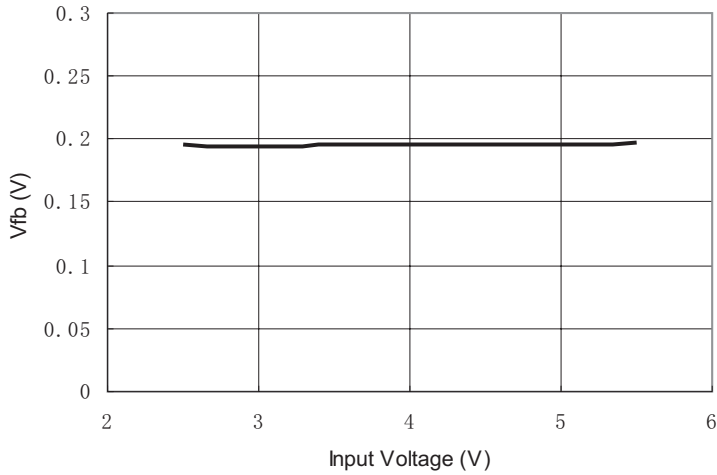

6. Feedback Voltage VS Temperature

10 LED,  $I_{LED}=20\text{mA}$

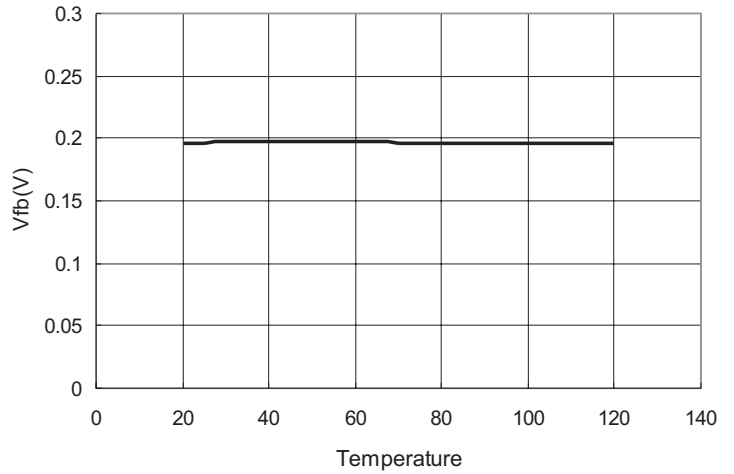

7. LED current VS Input voltage

$L=22\mu\text{H}$ , 10 LED

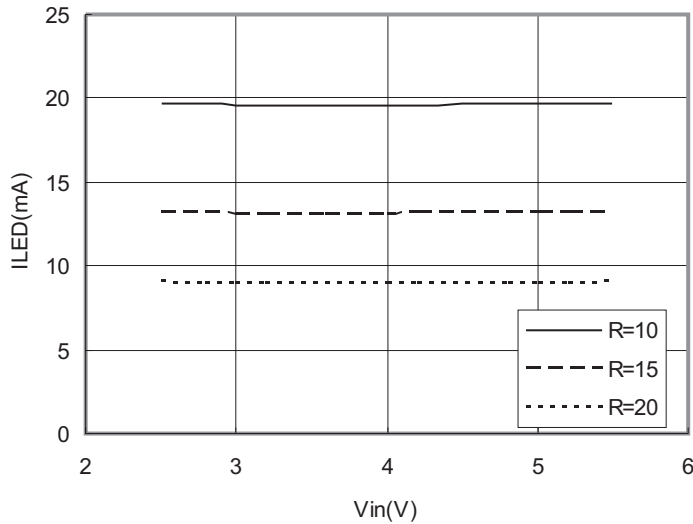

8. Frequency VS Input Voltage

10 LED

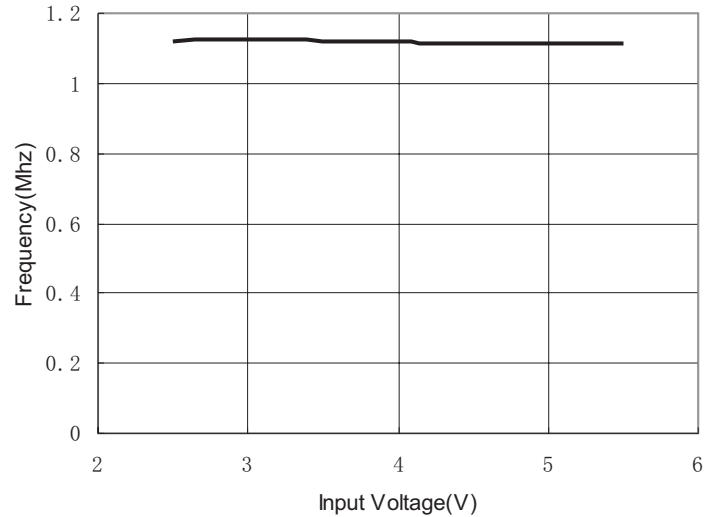

### Typical Operating Characteristics

$T_A=25^\circ\text{C}, V_{DD}=5\text{V}$ , unless otherwise noted.

9. Quiescent Current VS Input Voltage

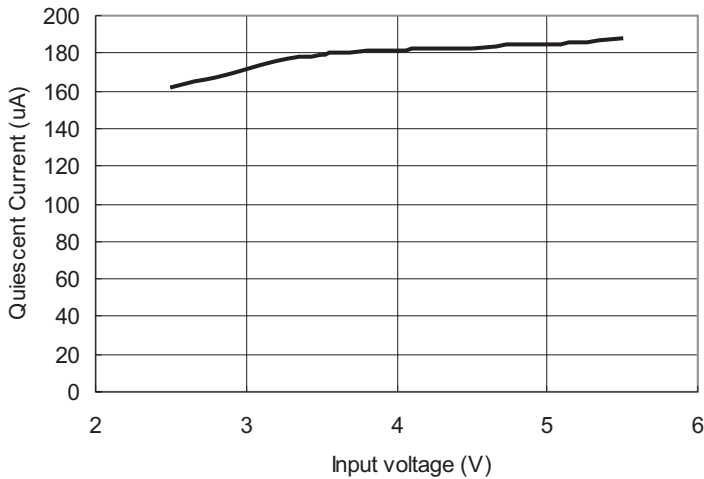

10. Frequency VS Temperature  
(10 LED,  $I_{LED}=20\text{mA}$ )

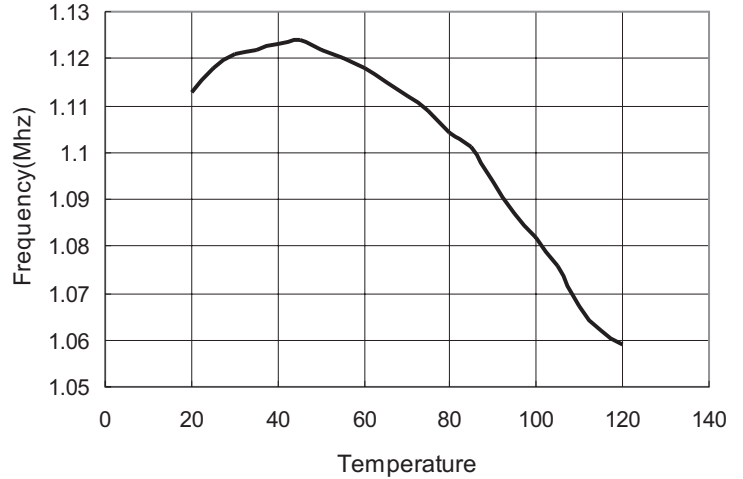

11. LED Current VS Duty Cycle of PWM  
(PWM@EN Pin)

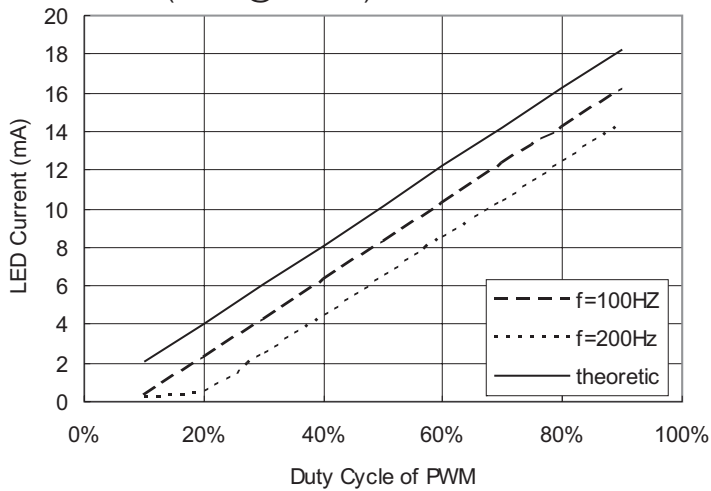

12. LED Current VS Duty Cycle of PWM  
(PWM@COMP Pin)

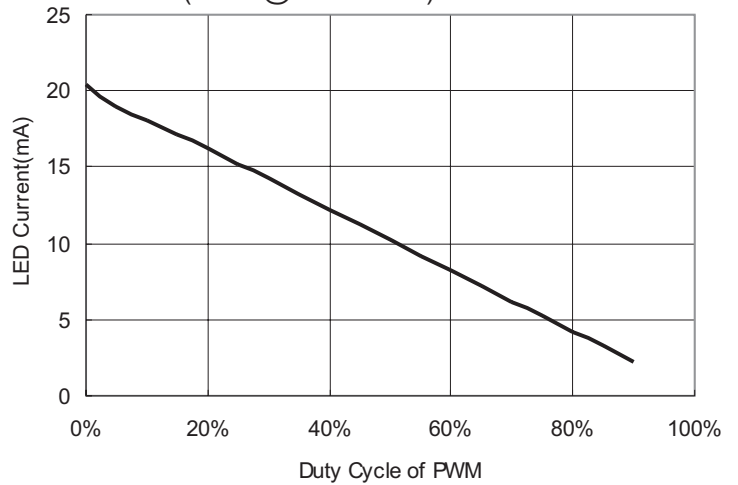

### Typical Operating Characteristics

$T_A=25^{\circ}\text{C}$ ,  $V_{DD}=5\text{V}$ , unless otherwise noted.

13. Start-up Waveform  
 $V_{in}=5\text{V}$ , 10LED,  $I_{led}=20\text{mA}$

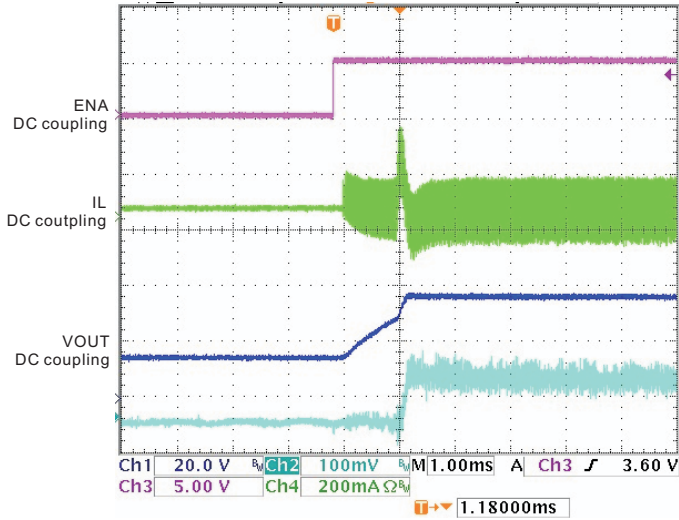

14. Steady State Waveform  
 $V_{in}=5\text{V}$ , 10LED,  $I_{led}=20\text{mA}$

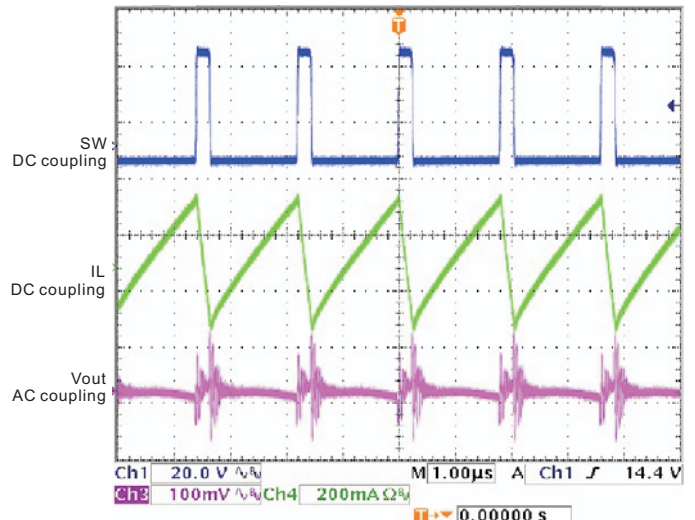

15. Open load

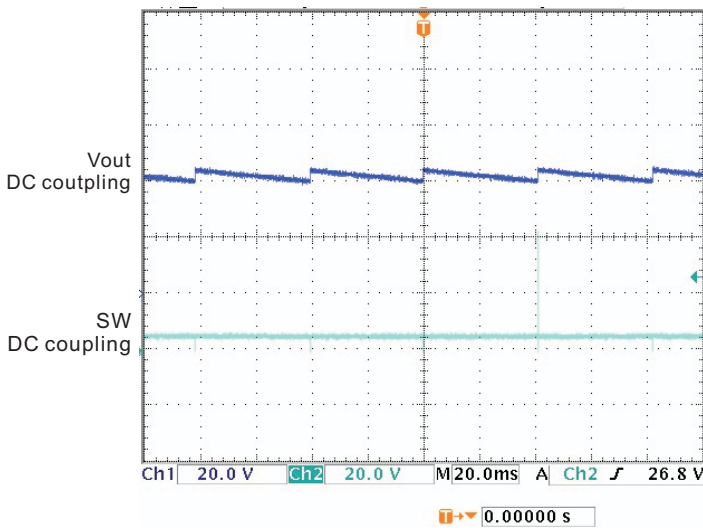

16. Open load

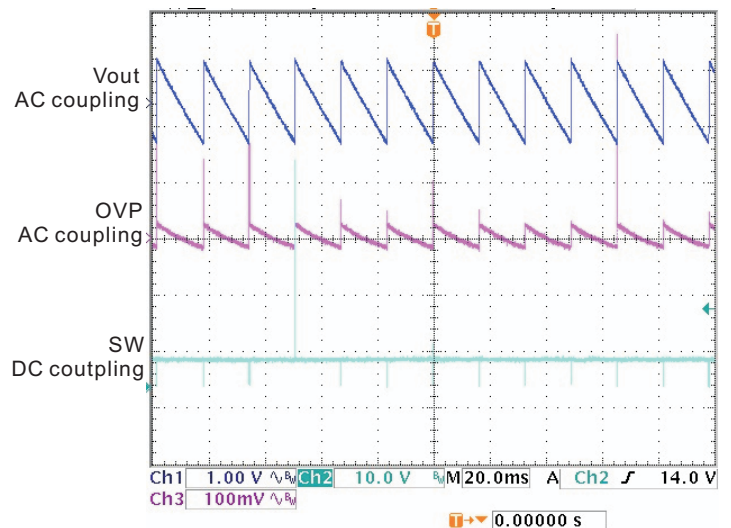



### Application Information

#### Inductor Selection

The selection of the inductor affects steady state operation as well as transient behavior and loop stability. These factors make it the most important component in power regulator design. There are three important inductor specifications, inductor value, DC resistance and saturation current. Considering inductor value alone is not enough.

The inductor value determines the inductor ripple current. Choose an inductor that can handle the necessary peak current without saturation, the inductor DC current given by:

$$I_{in\_dc} = V_{out} * I_{out} / (V_{in} * \eta) \quad \eta = \text{efficiency.}$$

Inductor values can have  $\pm 20\%$  tolerance with no current bias. When the inductor current approaches saturation level, its inductance can decrease 20% to 35% from the 0A value depending on how the inductor vendor defines saturation current. Using an inductor with a smaller inductance value causes discontinuous PWM when the inductor current ramps down to zero before the end of each switching cycle. This reduces the boost converter's maximum output current, causes large input voltage ripple and reduces efficiency. Large inductance value provides much more output current and higher conversion efficiency. For these reasons, an inductor within 4.7 $\mu$ H to 22 $\mu$ H value range is recommended.

#### Schottky Diode Selection

The high switching frequency of the PAM2841 demands a high-speed rectification for optimum efficiency. Ensure that the diode average and peak current rating exceeds the average output current and peak inductor current. In addition, the diode's reverse breakdown voltage must exceed the open protection voltage.

#### Input and Output Capacitor Selection

##### Input Capacitor

At least a 1 $\mu$ F input capacitor is recommended to reduce the input ripple and switching noise for normal operating conditions. Larger value and lower ESR (Equivalent Series Resistance) may be needed if the application require very low input ripple. It follows that ceramic capacitors are a good choice for applications. Note that the input capacitor should be located as close as possible

to the device.

##### Output Capacitor

The output capacitor is mainly selected to meet the requirement for the output ripple and loop stability. This ripple voltage is related to the capacitor's capacitance and its equivalent series resistance (ESR). A output capacitor of 1 $\mu$ F minimum is recommended and maybe need a larger capacitor. The total output voltage ripple has two components: the capacitive ripple caused by the charging and discharging on the output capacitor, and the ohmic ripple due to the capacitor's equivalent series resistance (ESR):

$$V_{RIPPLE} = V_{RIPPLE(C)} + V_{RIPPLE(ESR)}$$

$$V_{RIPPLE(C)} \approx \frac{1}{2} * (L / (C_{OUT} * ((V_{OUT(MAX)} - V_{IN(MIN)})))) * (I_{PEAK}^2 - I_{OUT}^2)$$

$$V_{RIPPLE(ESR)} = I_{PEAK} * R_{ESR(COUT)}$$

Where  $I_{PEAK}$  is the peak inductor current.

Multilayer ceramic capacitors are an excellent choice as they have extremely low ESR and are available in small footprints. Capacitance and ESR variation with temperature should be considered for best performance in applications with wide operating temperature ranges.

##### Dimming Control

There are 4 different types of dimming control methods:

##### 1). Using an External PWM Signal to EN Pin

With the PWM signal applied to the EN pin, the PAM2841 is alternately turned on or off by the PWM signal. The LEDs operate at either zero or full current. The average LED current changes proportionally with the duty cycle of the PWM signal. A 0% duty cycle turns off the PAM2841 and leads to zero LED current. A 100% duty cycle generates full current. Also the recommend dimming frequency is between 100Hz and 200Hz.

$$I_{AVE} = I_{STATE} * (T_{ON} - T_{STARTUP}) / (T_{ON} + T_{OFF})$$

where  $T_{ON}$ : on time of a period

$T_{STARTUP}$ : 0.85ms

$T_{OFF}$ : off time of a period

$I_{STATE}$ : on state current (full current)

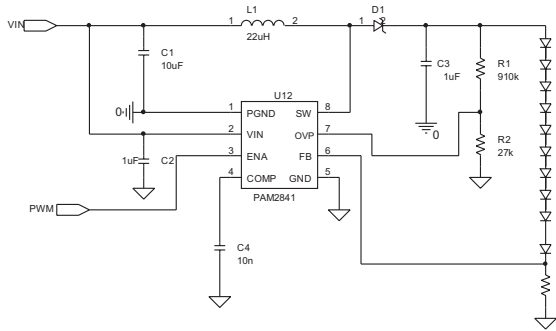

**Figure. 1**

### 2). Using an External PWM Signal to NMOS Gate.

When PWM signal is at high level, N MOSFET turned on, then pull comp pin down, then the LED current should be zero. When PWM signal is at low level, N MOSFET turned off. The circuit uses resistor R1 to set the on state current. The average LED current changes proportionally with the duty cycle of the PWM signal. A 100% duty cycle turns off the PAM2841 and leads to zero LED current. A 0% duty cycle generates full current.

$$I_{AVE} = I_{STATE} * (T_{ON} - T_{STARTUP}) / (T_{ON} + T_{OFF})$$

where  $T_{ON}$ : on time of a period

$T_{STARTUP}$ : 0.08ms

$T_{OFF}$ : off time of a period

$I_{STATE}$ : on state current (full current)

Also the recommend frequency is between 100 and 500Hz. Frequency < 100Hz can naturally causes LEDs to blink visibly.

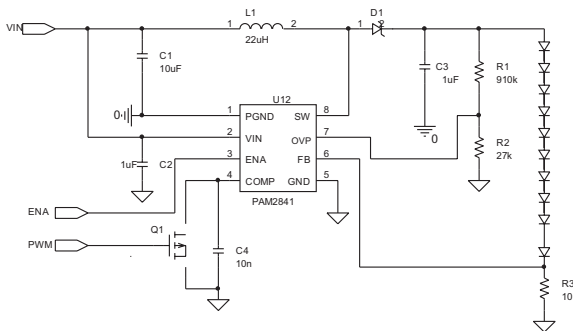

**Figure. 2**

### 3). Using a DC Voltage

For some applications, a simple and direct way to control brightness is use an external variable DC voltage to vary the voltage drop on feedback resistor. This will make the PAM2841 adjust the output current to follow the change of feedback voltage. The circuit is shown in Figure 3. As the DC voltage increases, the voltage drop on R4 increases and the voltage drop on R3 decreases. Thus, the LED current decreases. The selection of R4 and R5 will make the current from the variable DC source much smaller than the LED current and much larger than the FB pin current. For VCC range from 0V to 2V, the selection of resistors in Figure 3 gives dimming control of LED current from 0mA to 20mA.

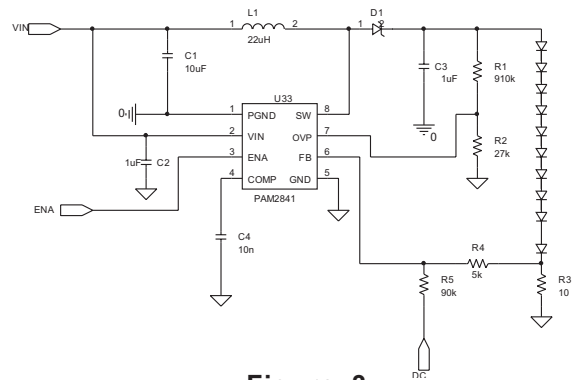

**Figure. 3**

### 4). Using a Filtered PWM Signal

The filtered PWM signal can be considered as an adjustable DC voltage. Such regulated signal is often with some grade of ripple because of some simple configuration of circuit. With appropriated arrangement of PWM frequency and level, and filter parameters, it can be used to replace the variable DC voltage source in dimming control. The circuit is shown in Figure 4.

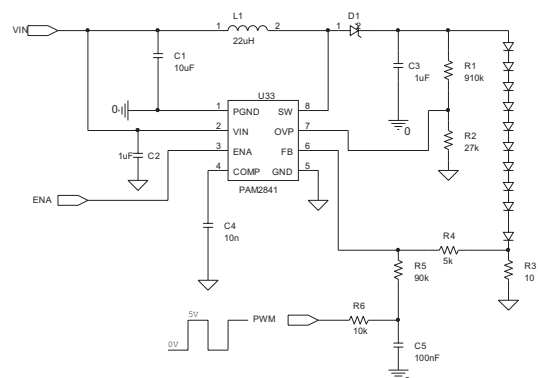

**Figure. 4**

### Layout Considerations

As for all switching power supplies, especially those in high frequency and high current ones, layout is an important design step. If layout is not carefully done, the regulator could suffer from instability as well as noise problems.

- (1) Use separate traces for power ground and signal ground. Power ground and signal ground are connected together to a quiet ground (input connector)
- (2) To prevent radiation of high frequency resonance, proper layout of the high frequency switching path is essential. Minimize the length and area of all traces connecting to the SW pin. The loop including the PWM switch, schottky diode and output capacitor, contains high current rising and falling in nanosecond and thus it should be kept as short as possible.
- (3) The input capacitor should be close to both the VIN pin and the GND pin in order to reduce the IC supply ripple.
- (4) Keep the signal ground traces short and as close to the IC as possible. Small signal components should be placed as close as possible to the IC, thus minimizing control signal noise interference.

### Layout Example

#### Top Layer

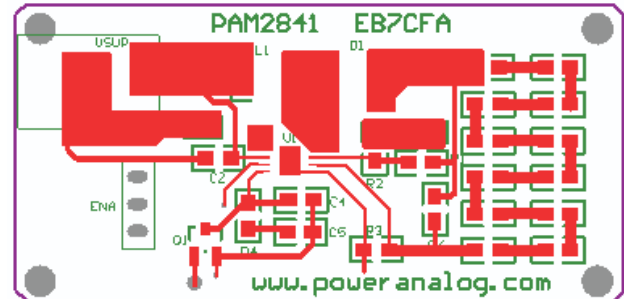

#### Bottom Layer

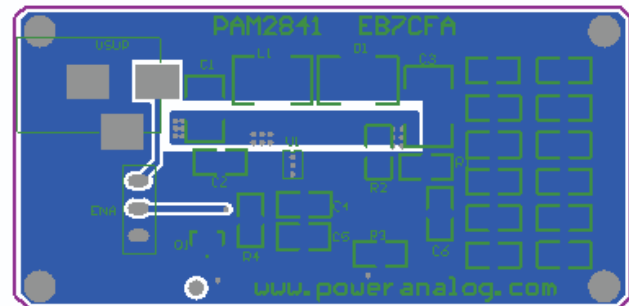



# PAM2841

## 1.5A SW Current, 40V Precision WLED Driver

### Ordering Information

PAM2841 X X

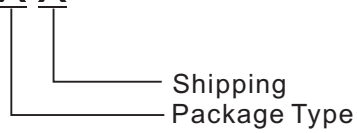

Part Number	Marking	Package	Shipping
PAM2841SR	P2841	MSOP-8	3,000 units/Tape & Reel
PAM2841GR	EMX YW	DFN 2x2-8	3,000 units/Tape & Reel

### Outline Dimensions

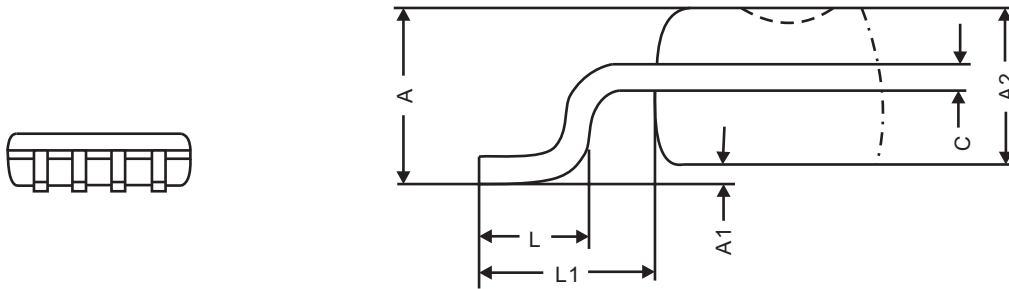
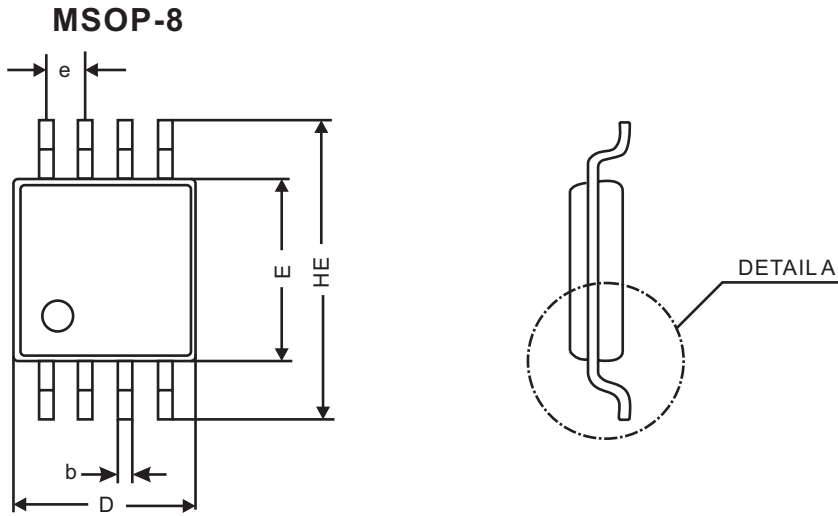

DETAILA(S=3:1)

REF.	Millimeter		REF.	Millimeter	
	Min	Max		Min	Max
A	--	1.10	L	0.40	0.70
A1	0.05	0.15	L1	0.95 BSC	
A2	0.78	0.94	B	0.22	0.38
D	2.90	3.10	C	0.08	0.23
E	2.90	3.10	e	0.65 BSC	
HE	4.75	5.05			

### Outline Dimensions

#### DFN 2x2

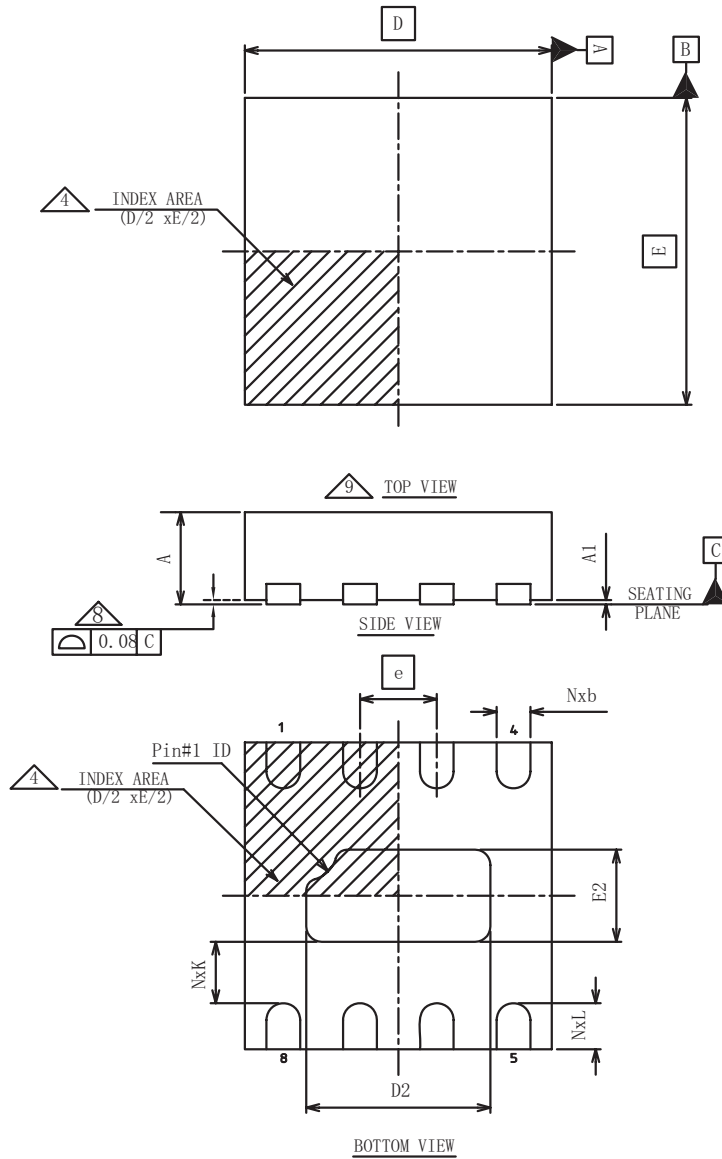

SYMBOL	COMMON DIMENSION		
	MIN	NOM	MAX
A	0.70	0.75	0.80
A1	0.00	0.02	0.05

Summary Table			
Lead Pitch (e)	Lead Count	Body Size	Pin #1 ID
0.50	8	2X2	R0.20

D BSC	2.00	
E BSC	2.00	
b	MIN	0.18
	NOM	0.25
	MAX	0.30
D2	MIN	1.05
	NOM	1.20
	MAX	1.30
E2	MIN	0.45
	NOM	0.60
	MAX	0.70
L	MIN	0.20
	NOM	0.30
	MAX	0.40
N	8	

Unit: Millimeters

## Данный компонент на территории Российской Федерации

### Вы можете приобрести в компании MosChip.

Для оперативного оформления запроса Вам необходимо перейти по данной ссылке:

<http://moschip.ru/get-element>

Вы можете разместить у нас заказ для любого Вашего проекта, будь то серийное производство или разработка единичного прибора.

В нашем ассортименте представлены ведущие мировые производители активных и пассивных электронных компонентов.

Нашей специализацией является поставка электронной компонентной базы двойного назначения, продукции таких производителей как XILINX, Intel (ex.ALTERA), Vicor, Microchip, Texas Instruments, Analog Devices, Mini-Circuits, Amphenol, Glenair.

Сотрудничество с глобальными дистрибьюторами электронных компонентов, предоставляет возможность заказывать и получать с международных складов практически любой перечень компонентов в оптимальные для Вас сроки.

На всех этапах разработки и производства наши партнеры могут получить квалифицированную поддержку опытных инженеров.

Система менеджмента качества компании отвечает требованиям в соответствии с ГОСТ Р ИСО 9001, ГОСТ РВ 0015-002 и ЭС РД 009

### Офис по работе с юридическими лицами:

105318, г.Москва, ул.Щербаковская д.3, офис 1107, 1118, ДЦ «Щербаковский»

Телефон: +7 495 668-12-70 (многоканальный)

Факс: +7 495 668-12-70 (доб.304)

E-mail: [info@moschip.ru](mailto:info@moschip.ru)

Skype отдела продаж:

moschip.ru

moschip.ru\_4

moschip.ru\_6

moschip.ru\_9