

Description

Single, double and three pole thermal-magnetic circuit breakers with high rupture capacity to UL 489 (5 kA), EN/IEC 60934 (6kA) and UL 1077 (5 kA). With toggle actuation, positively trip-free mechanism, a choice of characteristic curves and a wide range of current ratings in finely graded steps from 0.1 A through 32 A. Auxiliary contacts (make or break contacts) are optionally available. Track-mountable design, width only 12.5 mm. Ease of wiring by means of an integral busbar concept: line entry busbar LINE+ and signal busbars/signal jumpers.

US patent number: US 8,098,119 B2 (Modularity)

US patent number: US 7,978,033 B2 (Release Mechanism)

US patent number: US 7,834,290 B2 (Quenching Chamber)

Typical applications

Protection of power supplies, equipment and cables in centralised control systems and in decentralised installations serving automation, petro-chemical, power plant, steel industry and similar industrial applications.

Ordering Information

Type number	4220 thermal-magnetic high performance circuit breaker
Mounting	T1 track-mounting
Number of poles	1 single pole 2 double pole 3 three pole
Additional feature	0 without actuator guard 1 with actuator guard
Main terminals	K0 screw terminals 16 mm ² / 10 mm ²
Characteristic curve	F1 thermal-magnetic, extremely fast, DC F2 thermal-magnetic, fast, AC/DC M1 thermal-magnetic, medium delay, AC/DC T1 thermal-magnetic, long delay, AC/DC
Auxiliary contacts	H0 without H1 with auxiliary contacts in all poles H2 with auxiliary contacts only in pole 1 (2-pole plus) H3 with auxiliary contacts only in poles 1+3 (3-pole plus) H4 with auxiliary contacts only in pole 2 (3-pole plus) H5 with auxiliary contacts only in the last pole H6 with auxiliary contacts only in poles 1+2 (3-pole plus)
Auxiliary contact function	0 without 2 make contact (N/O) 3 break contact (N/C) A pole 1 make contact, all other poles break contacts (2-pole plus) B poles 1+2 make contacts, other poles break contacts (3-pole plus) C pole 1 break contact, other poles make contacts (2-pole plus)
Auxiliary contacts – terminal design	0 without 1 screw terminals 1 mm ²
Voltage rating	A ≤ AC 277 V or ≤ DC 60 V
Current rating range	0.1...32 A
Approval logo (optional)	V UL 489 (1-pole)
Ordering example	4220 - T1 1 0 - K0 M1- H1 2 1 - A - 10 A - V



Technical data

For further details please see catalogue section: Technical Information

Voltage rating	AC 240 V; 3 AC 415 V (50/60 Hz); DC 60 V UL: AC 120 V; AC 277 V; 3 AC 415 V; DC 60 V
Current rating range	0.1...32 A
Auxiliary circuit	DC 10 - 30 V, 10 - 500 mA, resistive
Typical life	IEC 60934 AC 240/415 V 1,000 cycles at 1 x I _N , ind. load AC 240 V: 6,000 cycles at 1 x I _N , inductive load DC 60 V: 6,000 cycles at 1 x I _N , resistive load UL 489 AC 120 V: 6,000 cycles at 1 x I _N , inductive load UL 1077 AC 277/480 V 3,000 cycles at 1 x I _N , inductive load AC 277 V: 6,000 cycles at 1 x I _N , inductive load DC 60 V: 6,000 cycles at 1 x I _N , resistive load
Ambient temperature	-30...+60 °C (-22...+140 °F, T60)
Storage temperature	-40...+60 °C (-40...+140 °F)
Insulation co-ordination	IEC 60664 2.5 kV / 2 re-inforced insulation in the operating area
Dielectric strength operating area	IEC 60934 test voltage AC 3,000 V (reinforced insulation) pole to pole test voltage AC 1,500 V main circuit to auxiliary circuit test voltage AC 1,500 V open main circuit test voltage AC 1,500 V open auxiliary circuit test voltage AC 250 V
Insulation resistance	> 100 MΩ (DC 500 V)
Interrupting capacity I_{nc} PC1 IEC 60934	AC 240 V, AC 240/415 V: 6,000 A DC 60 V: 6,000 A
Interrupting capacity UL 489	AC 120 V: 5,000 A
Interrupting capacity UL 1077	AC 277 V, AC 277/480 V: 5,000 A DC 60 V: 5,000 A
Protection class (IEC 60529)	operating area IP30 terminal area IP00
Vibration (sinusoidal)	± 0.38 mm (10-57 Hz), 5 g (57-500 Hz) test to IEC 60068-2-6, test Fc, 10 frequency cycles/axis
Shock	25 g (11 ms) test to IEC 60068-2-27, test Ea
Corrosion	96 hrs in 5 % salt mist, test to IEC 60068-2-11, test Ka
Humidity	240 hrs in 95 % RH, to IEC 60068-2-78, test Cab
Housing material	moulded material
Mounting	on symmetrical rail to EN 50022-35x7.5
Mounting dimension (w x h x d)	12.5 x 89.3 x 87.1 (per pole)

Technical data

LINE terminal	(LINE and/or DC+)
screw terminals	M5
max. cable cross section	
flexible with wire end ferrule w/wo plastic sleeve	1 – 16 mm ²
multi-lead connection (2 identical cables)	
flexible with wire end ferrule without plastic sleeve	1 – 6 mm ²
flexible with TWIN wire end ferrule with plastic sleeve	0.75 – 10 mm ²
wire stripping length	14 mm
tightening torque	2.5 – 3 Nm
LOAD terminal	
screw terminals	M4
max. cable cross section	
flexible with wire end ferrule w/wo plastic sleeve	0.5 – 10 mm
multi-lead connection (2 identical cables)	
flexible with wire end ferrule without plastic sleeve	0.5 – 2.5 mm ²
flexible with TWIN wire end ferrule with plastic sleeve	0.5 – 6 mm ²
wire stripping length	10 mm
tightening torque	1.2 – 1.4 Nm
Auxiliary contact terminals	
screw terminals	M2
max. cable cross section	
flexible with wire end ferrule w/wo plastic sleeve	0.25 – 0.75 mm ²
multi-lead connection (2 identical cables)	
flexible with wire end ferrule without plastic sleeve	0.25 – 0.34 mm ²
wire stripping length	6 mm
tightening torque	0.22 – 0.25 Nm
Mass	approx. 90 g per pole with aux. contact

Current ratings and typical internal resistance values

Current rating (A)	Internal resistance (Ω)			
	F1	F2	M1	T1
trip curve	fast DC only	fast AC + DC	medium delay AC + DC	long delay AC + DC
0.1	166	148	122	104
0.2	45	41	34	29
0.3	19	17	14	12
0.4	12	11	7.9	7.3
0.5	6.8	5.6	4.7	4.2
0.6	4.9	4.5	3.7	3.4
0.8	2.9	2.7	2.1	1.7
1	1.8	1.6	1.3	1.1
1.5	0.93	0.76	0.62	0.58
2	0.47	0.40	0.34	0.31
2.5	0.30	0.27	0.23	0.21
3	0.22	0.20	0.17	0.15
3.5	0.17	0.16	0.13	0.12
4	0.11	0.11	0.084	0.077
5	0.086	0.082	0.066	0.062
6	0.064	0.062	0.053	0.049
8	0.029	0.026	≤ 0.02	≤ 0.02
10	≤ 0.022	≤ 0.02	≤ 0.02	≤ 0.02
12	≤ 0.02	≤ 0.02	≤ 0.02	≤ 0.02
15	≤ 0.02	≤ 0.02	≤ 0.02	≤ 0.02
16	≤ 0.02	≤ 0.02	≤ 0.02	≤ 0.02
18	≤ 0.02	≤ 0.02	≤ 0.02	≤ 0.02
20	≤ 0.02	≤ 0.02	≤ 0.02	≤ 0.02
25	≤ 0.02	≤ 0.02	≤ 0.02	≤ 0.02
32	≤ 0.02	≤ 0.02	≤ 0.02	≤ 0.02

Dimensions

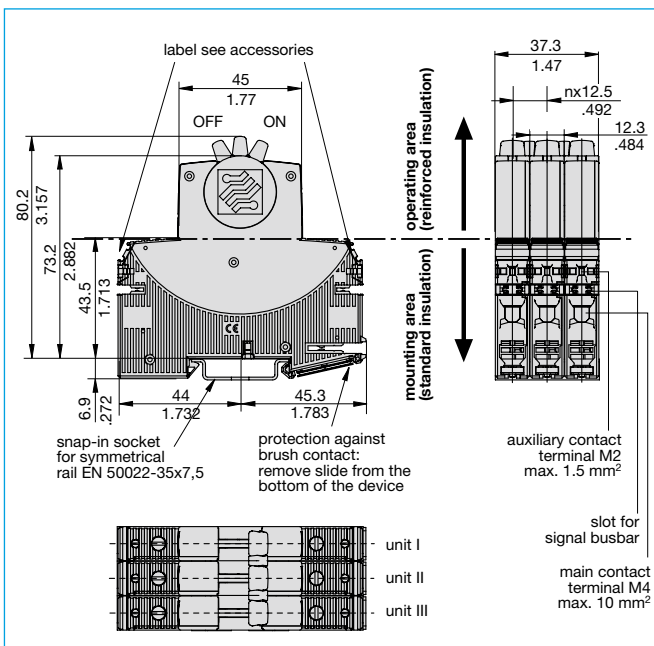

Installation drawing

allowable mounting position: **vertical**

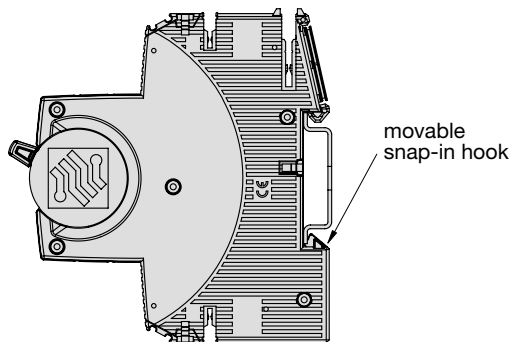

Internal connection diagrams

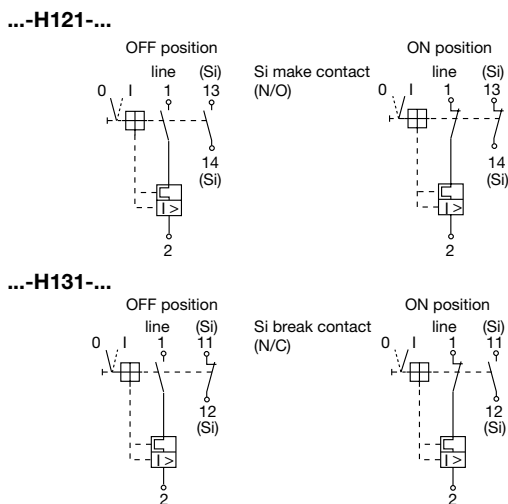

This is a metric design and millimeter dimensions take precedence ($\frac{\text{mm}}{\text{inch}}$)

Termination examples

**4220-T with busbars and signal busbars
(auxiliary contacts connected in parallel)**

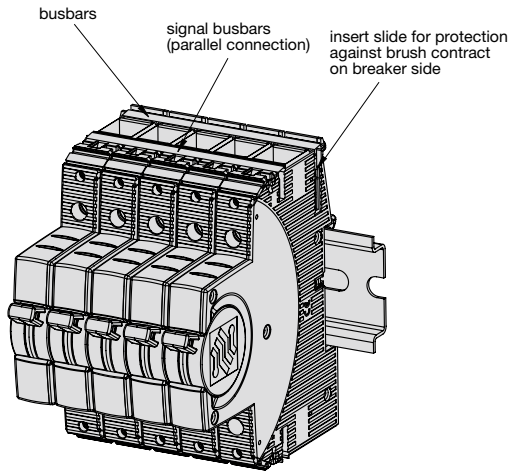

**4220-T with busbars and jumpers
(auxiliary contacts connected in parallel)**

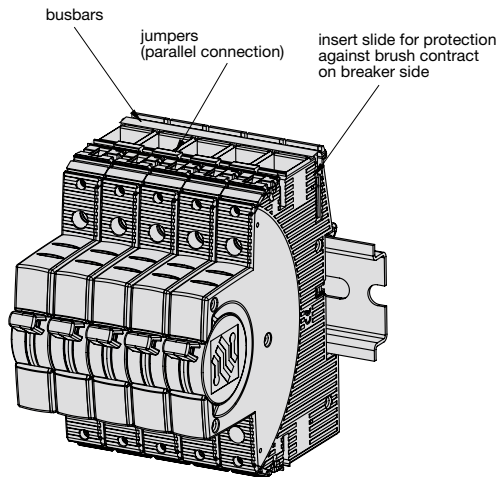

**4220-T with busbars and signal busbars
(auxiliary contacts connected in serie)**

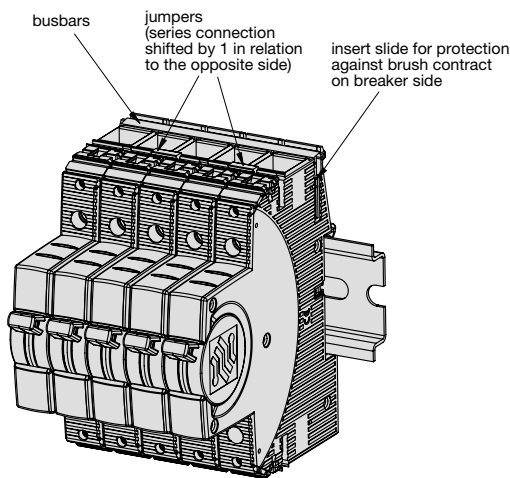

Busbars, signal busbars and jumpers: see accessories

Accessories

Description	Part number
busbar grey, 500 mm length, can be cut to length	X 222 611 02
signal busbar blue, 500 mm length, can be cut to length	X 222 005 01
signal busbar red, 500 mm length, can be cut to length	X 222 005 02
signal busbar grey, 500 mm length, can be cut to length	X 222 005 03
signal busbar grey (packing unit 25 pcs)	X 222 486 25
Label (packing unit 50 pcs) or from Phoenix ZBF 12	X 222 977 50

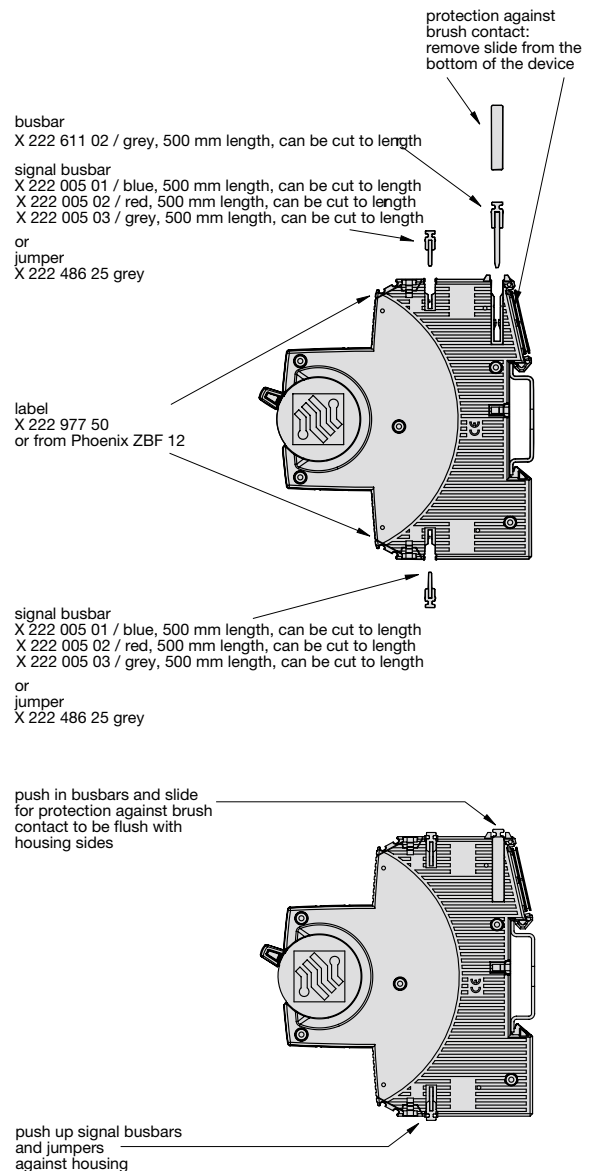

This is a metric design and millimeter dimensions take precedence ($\frac{mm}{inch}$)

Typical time/current characteristics

F1 thermal, magnetic fast (DC)

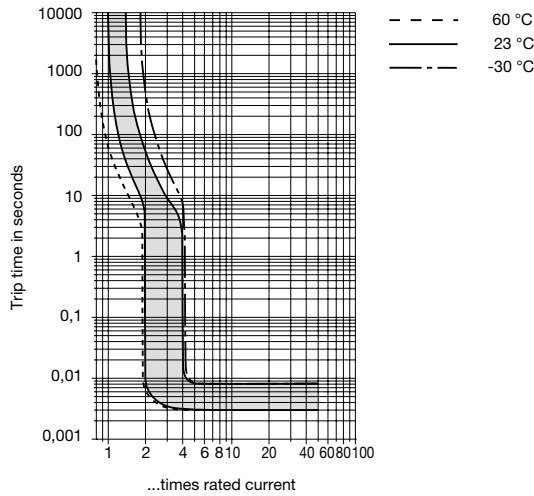

F2 thermal, magnetic fast (AC/DC)

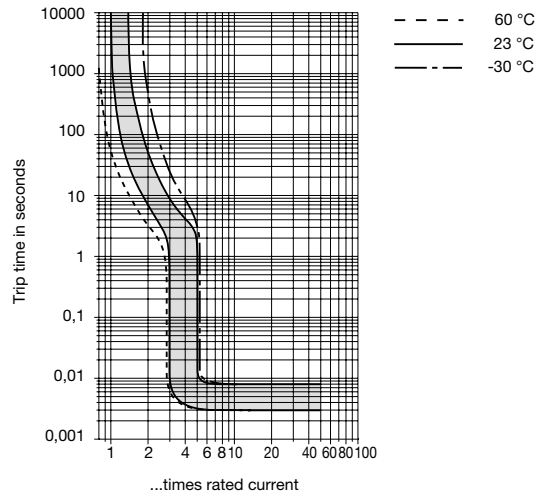

M1 thermal, magnetic medium delay (AC/DC)

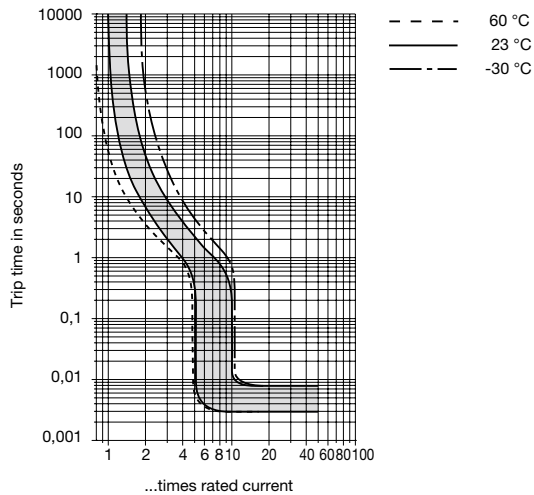

T1 thermal, magnetic long delay (AC/DC)

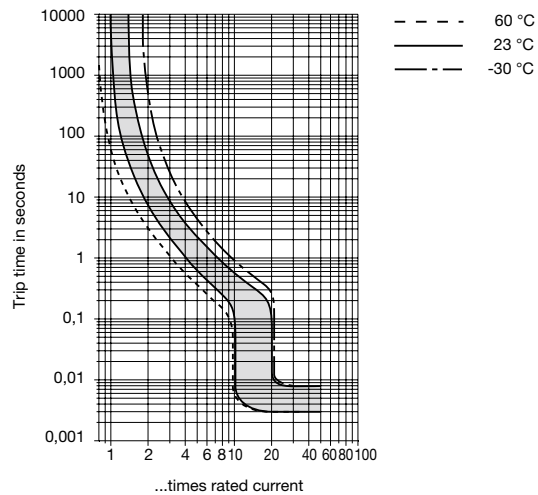

The time/current characteristic curve depends on the ambient temperature prevailing. In order to eliminate nuisance tripping, please multiply the circuit breaker current ratings by the derating factor shown below. See also section Technical information.

Ambient temp. °F	-22	-4	+14	+32	+50	+73.4	+86	+104	+122	+140
°C	-30	-20	-10	0	+10	+23	+30	+40	+50	+60
Derating factor	0.76	0.79	0.83	0.88	0.93	1	1.04	1.12	1.22	1.35

Magnetic tripping currents are increased by 30 % on DC supplies.

When several devices are mounted together, an air gap between each is recommended. If this is not possible, each device should carry only 80 % of its rating.

Approvals

Authority	Standard	Rated voltage	Current ratings
VDE	IEC/EN 60934	AC 240/415 V AC 240 V DC 60 V	0.1 A...32 A 0.1 A...32 A 0.1 A...32 A
UL	UL 1077 C22.2 No 235	AC 277/480 V AC 277 V DC 60 V	0.1 A...32 A 0.1 A...32 A 0.1 A...32 A
UL	UL 489	AC 120 V DC 60 V	0.1 A...32 A (single pole) 0.1 A...32 A (single pole)

All dimensions without tolerances are for reference only. In the interest of improved design, performance and cost effectiveness the right to make changes in these specifications without notice is reserved. Product markings may not be exactly as the ordering codes. Errors and omissions excepted.

Данный компонент на территории Российской Федерации

Вы можете приобрести в компании MosChip.

Для оперативного оформления запроса Вам необходимо перейти по данной ссылке:

<http://moschip.ru/get-element>

Вы можете разместить у нас заказ для любого Вашего проекта, будь то серийное производство или разработка единичного прибора.

В нашем ассортименте представлены ведущие мировые производители активных и пассивных электронных компонентов.

Нашей специализацией является поставка электронной компонентной базы двойного назначения, продукции таких производителей как XILINX, Intel (ex.ALTERA), Vicor, Microchip, Texas Instruments, Analog Devices, Mini-Circuits, Amphenol, Glenair.

Сотрудничество с глобальными дистрибьюторами электронных компонентов, предоставляет возможность заказывать и получать с международных складов практически любой перечень компонентов в оптимальные для Вас сроки.

На всех этапах разработки и производства наши партнеры могут получить квалифицированную поддержку опытных инженеров.

Система менеджмента качества компании отвечает требованиям в соответствии с ГОСТ Р ИСО 9001, ГОСТ РВ 0015-002 и ЭС РД 009

Офис по работе с юридическими лицами:

105318, г.Москва, ул.Щербаковская д.3, офис 1107, 1118, ДЦ «Щербаковский»

Телефон: +7 495 668-12-70 (многоканальный)

Факс: +7 495 668-12-70 (доб.304)

E-mail: info@moschip.ru

Skype отдела продаж:

moschip.ru

moschip.ru_4

moschip.ru_6

moschip.ru_9