

LL01ED-AYxxL Single Color Lens

Datasheet

For CREE MC-E Single-Color LEDs

Features:

- High efficiency
- Available in 2 beam Patterns
- Optimized for uniform effects
- Lens with Housing

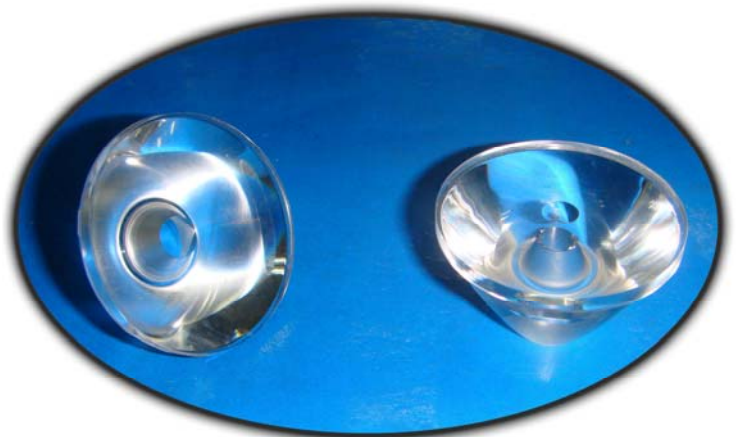

Typical applications :

- Stage Lighting
- Street Lights
- Decorative Light
- Architectural Lighting
- Down Light



Table of Contents

• General Information.....	2
• General Specifications.....	3
• Optical Specifications.....	3
• Mechanical Specifications.....	4
• Illumination charts.....	6
• Package Specifications.....	7
• Product Nomenclature.....	8

General Information

• Compatible Led Type :

The LL01ED-AYxxL Single lens are optimized for Alone Single-Color (Cree MC-E White and Warm white) Cree LEDs,from Cree ,Inc.⁽¹⁾

• Beam Angle Type :

An optimized profile integrate different front shape enable the generation of two different lens models: Smallest beam (20deg)and Medium beam (35deg).⁽²⁾

• The Way to Assembly :

The housing that can use the MR16 series aluminum cup or by oneself develop to apply

***Manually installation or if necessary thermal glue are recommended.**

• Function :

LL01ED-AYxxL provides exceptional color uniform result with the highest efficiency through careful engineering and precision manufacturing process.

Notes:

(1) Cree MC-E is a trademark of Cree,Inc , for technical information on LEDs, please refer to Cree,Inc, www.cree.com/xlamp.

(2) Typical beam divergence will be affected by different color of LEDs.

General Specifications

- Lens Material Optical Grade PMMA PC
- Operating Temperature range -40°C ~ + 70°C (upper limit +80°C)
- Storage Temperature range -40°C ~ + 70°C (upper limit +80°C)
- *Average transmittance in visible spectrum 400nm~700nm > 90%

Optical Specifications [Typical beam Angle and intensity (cd/lm) of LL01 lenses]

- CREE MC-E

Part Number	Typical Cone Angle (degree) ⁽³⁾ with CREE MC-E	
	White LEDs ○	Warm white LEDs ●
LL01ED-AY10L	19	22
LL01ED-AY38L	35	37

The typical cone angle the full angle measured where the luminous intensity is 90% of the peak value of intensity. That typical cone varies with LED color due to different chip size and chip position tolerance.

Part Number	Typical on axis intensity (cd/lm) ⁽⁴⁾ with CREE MC-E	
	White LEDs ○	Warm white LEDs ●
LL01ED-AY10L	1700	1480
LL01ED-AY38L	1300	1050s

Luminous intensity depends on the flux binning and tolerance of the LEDs. Please refer to the LEDs datasheet for more detail on flux binning and mechanical tolerance.

Notes:

- (3) The typical divergence will be changed by different color, chip size and chip position tolerance.
The typical total divergence is the full angle measured where the luminous intensity is half of the peak value.
- (4) The efficiency value listed above is the total value of the whole lens model, the value depends on the total flux of the LED used. Luminous intensity depends on the LEDs flux and its tolerances, for more details of LED flux, please check Cree datasheet at www.cree.com/xlamp

Mechanical Specifications

• Usage and Maintenance :

1. If necessary, clean lenses with mild soap, water and soft cloth
2. Never use any commercial cleaning solvents on lenses, like alcohol
3. Please handle or install lenses with wearing gloves, skin oils may damage lens or its optical characteristic.

1. Lens + Leds+MCPCB assembly instruction:

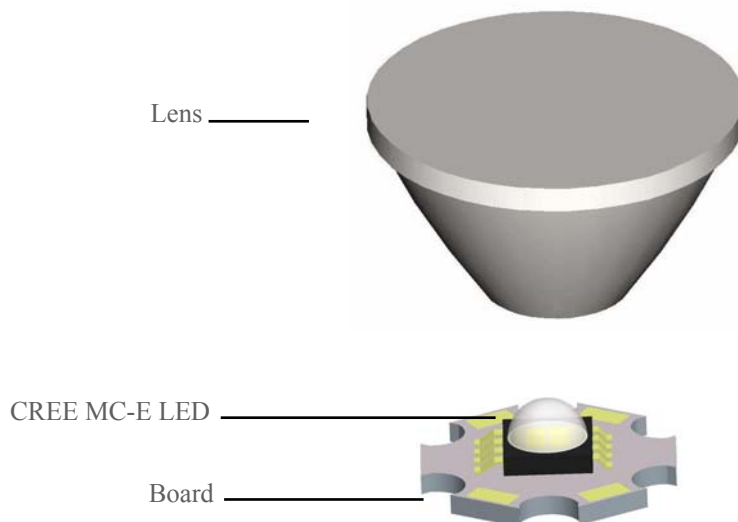

2. View assembly lens with MCPCB:

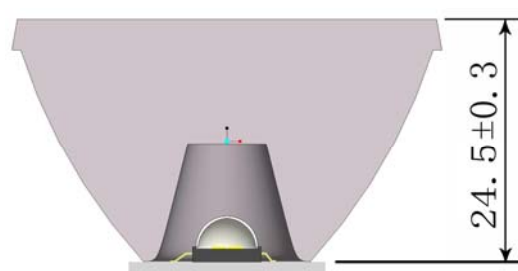

3. LL01ED-AY10L Dimensions and Top Views:

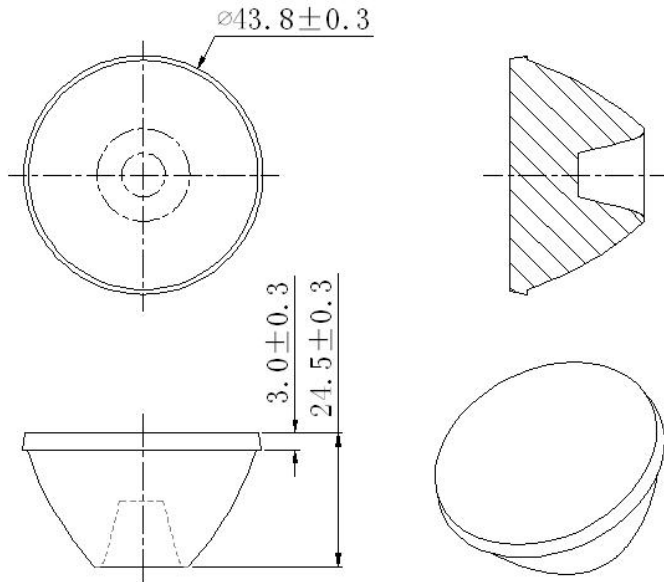

4. LL01ED-AY38L Dimensions and Top Views :

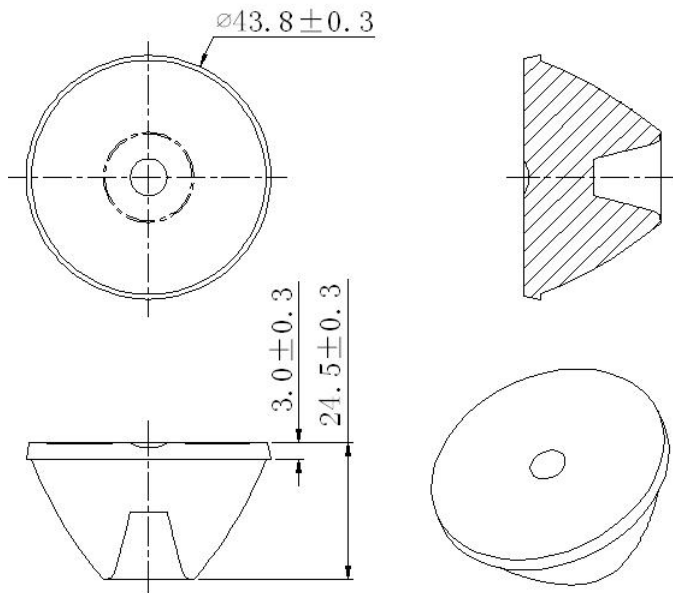

Notes:

- (1) All dimensions are in mm.
- (2) Drawing not to scale.
- (3) Collimator material is PMMA.

Illumination charts

*CREE single white LED: MC-E

LL01ED-AY10L

1. Beam Pattern



2. Angular Intensity Distribution

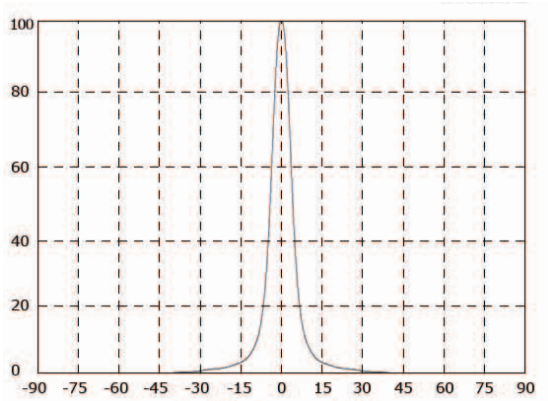

3. Shine on one degree diagram

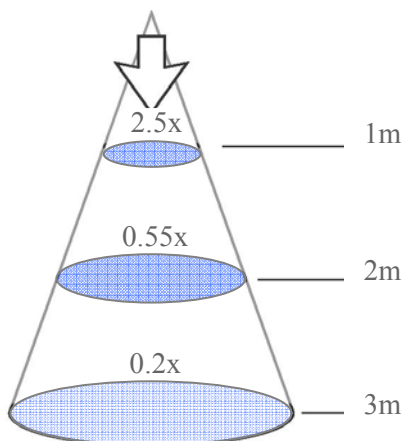

LL01ED-AY38L

1. Beam Pattern

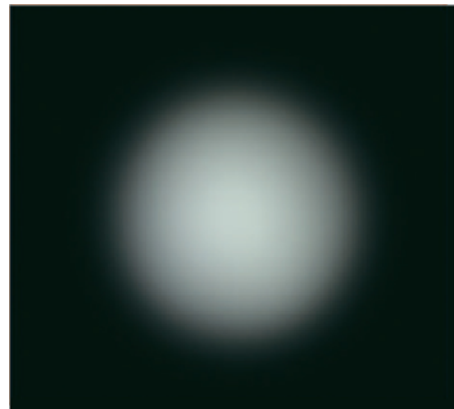

2. Angular Intensity Distribution

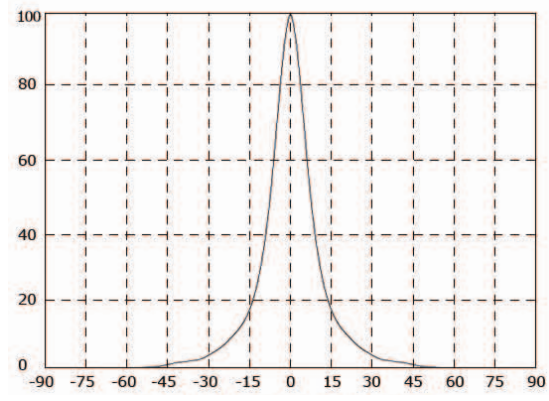

3. Shine on one degree diagram

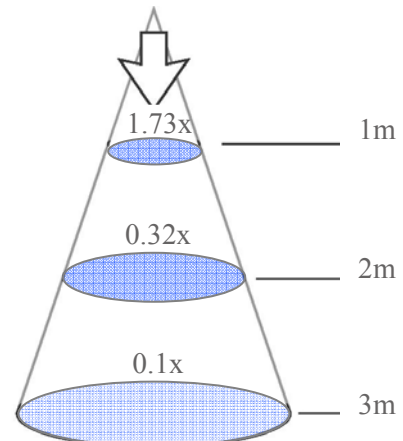

Package

Item	Quantity	Total	Size (long * width * high)
Tray		36pcs	34*30*3.5 cm
Inner box	7tray/box	252pcs	35*31*21 cm
Outer box	2 inner box/outer box	504pcs	64.7*36.5*24 cm

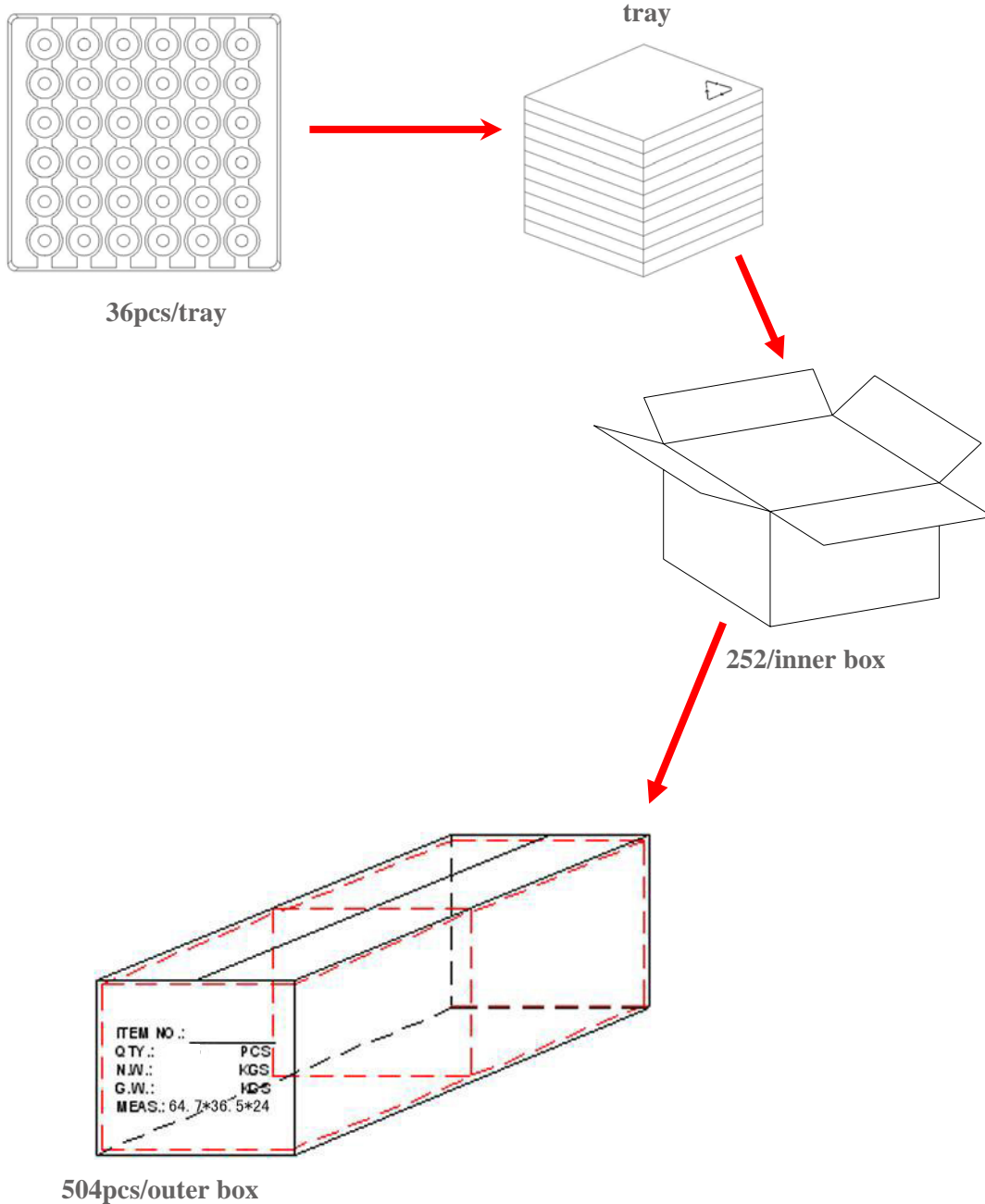

Product Nomenclature

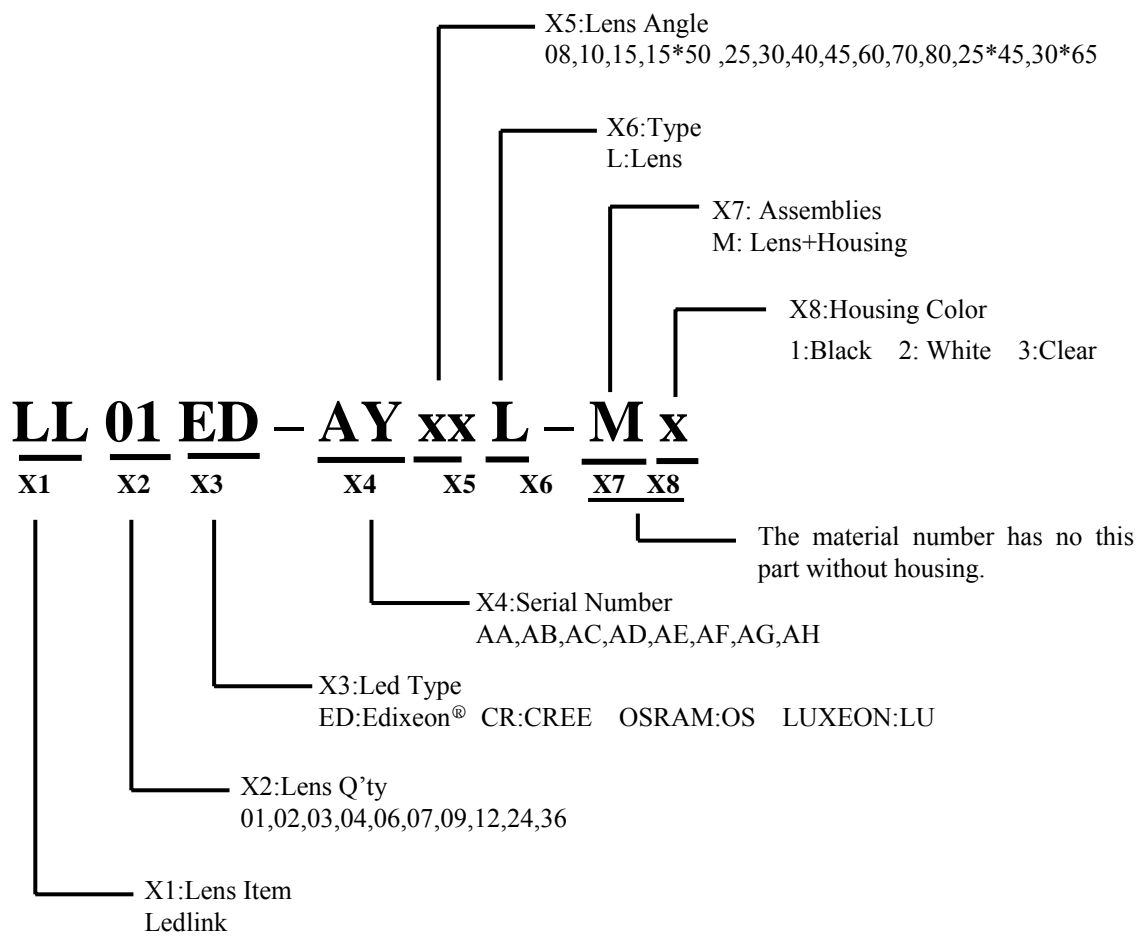

Данный компонент на территории Российской Федерации

Вы можете приобрести в компании MosChip.

Для оперативного оформления запроса Вам необходимо перейти по данной ссылке:

<http://moschip.ru/get-element>

Вы можете разместить у нас заказ для любого Вашего проекта, будь то серийное производство или разработка единичного прибора.

В нашем ассортименте представлены ведущие мировые производители активных и пассивных электронных компонентов.

Нашей специализацией является поставка электронной компонентной базы двойного назначения, продукции таких производителей как XILINX, Intel (ex.ALTERA), Vicor, Microchip, Texas Instruments, Analog Devices, Mini-Circuits, Amphenol, Glenair.

Сотрудничество с глобальными дистрибьюторами электронных компонентов, предоставляет возможность заказывать и получать с международных складов практически любой перечень компонентов в оптимальные для Вас сроки.

На всех этапах разработки и производства наши партнеры могут получить квалифицированную поддержку опытных инженеров.

Система менеджмента качества компании отвечает требованиям в соответствии с ГОСТ Р ИСО 9001, ГОСТ РВ 0015-002 и ЭС РД 009

Офис по работе с юридическими лицами:

105318, г.Москва, ул.Щербаковская д.3, офис 1107, 1118, ДЦ «Щербаковский»

Телефон: +7 495 668-12-70 (многоканальный)

Факс: +7 495 668-12-70 (доб.304)

E-mail: info@moschip.ru

Skype отдела продаж:

moschip.ru

moschip.ru_4

moschip.ru_6

moschip.ru_9