

DS1135

3-in-1 High-Speed Silicon Delay Line

FEATURES

- All-Silicon Timing Circuit
- Three Independent Buffered Delays
- Stable and Precise Over Temperature and Voltage
- Leading and Trailing Edge Precision Preserves the Input Symmetry
- Vapor Phasing, IR, and Wave Solderable
- Available in Tape and Reel
- Commercial and Industrial Temperature Ranges Available
- 5V Operation (Refer to DS1135L for 3V Operation)
- Recommended Replacement for DS1013 and DS1035

PIN ASSIGNMENT



DS1135Z 8-Pin SO (150 mils)

PIN DESCRIPTION

| | |
|-----------------|------------------|
| IN1-IN3 | - Input Signals |
| OUT1-OUT3 | - Output Signals |
| V _{CC} | - +5V Supply |
| GND | - Ground |

DESCRIPTION

The DS1135 series is a low-power, +5V high-speed version of the popular DS1013 and DS1035.

The DS1135 series of delay lines have three independent logic buffered delays in a single package. The device is our fastest 3-in-1 delay line. It is available in a standard 8-pin 150-mil SO.

The device features precise leading and trailing edge accuracy. It has the inherent reliability of an all-silicon delay line solution. Each output is capable of driving up to 10 LS loads.

Standard delay values are indicated in Table 1.

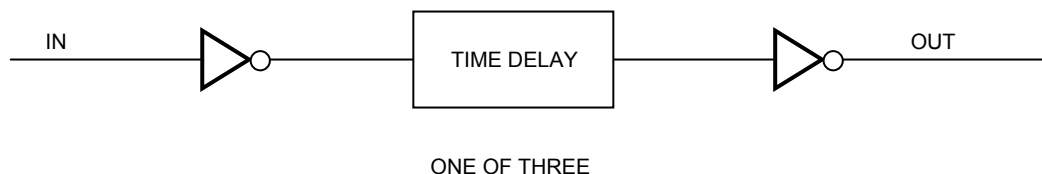
LOGIC DIAGRAM Figure 1**PART NUMBER DELAY TABLE (t_{PLH} , t_{PHL})** Table 1

| PART NUMBER | DELAY PER OUTPUT (ns) | INITIAL TOLERANCE (Note 1) | TOLERANCE OVER TEMP AND VOLTAGE (Note 2) | |
|-------------|-----------------------|----------------------------|--|----------------|
| | | | 0°C to +70°C | -40°C to +85°C |
| DS1135Z-6+ | 6/6/6 | ±1.0ns | ±1.0ns | ±1.5ns |
| DS1135Z-8+ | 8/8/8 | ±1.0ns | ±1.0ns | ±1.5ns |
| DS1135Z-10+ | 10/10/10 | ±1.0ns | ±1.0ns | ±1.5ns |
| DS1135Z-12+ | 12/12/12 | ±1.0ns | ±1.0ns | ±1.5ns |
| DS1135Z-15+ | 15/15/15 | ±1.0ns | ±1.5ns | ±2ns |
| DS1135Z-20+ | 20/20/20 | ±1.0ns | ±1.5ns | ±2ns |
| DS1135Z-25+ | 25/25/25 | ±1.5ns | ±1.5ns | ±2ns |
| DS1135Z-30+ | 30/30/30 | ±1.5ns | ±1.5ns | ±2ns |

NOTES:

1. Nominal conditions are +25°C and $V_{CC} = +5.0V$.
2. Voltage range of 4.75V to 5.25V.
3. Delay accuracies are for both leading and trailing edges.

TEST SETUP DESCRIPTION

Figure 2 illustrates the hardware configuration used for measuring the timing parameters of the DS1135. The input waveform is produced by a precision pulse generator under software control. Time delays are measured by a time interval counter (20ps resolution) connected to the output. The DS1135 output taps are selected and connected to the interval counter by a VHF switch control unit. All measurements are fully automated with each instrument controlled by the computer over an IEEE 488 bus.

DS1135 TEST CIRCUIT Figure 2

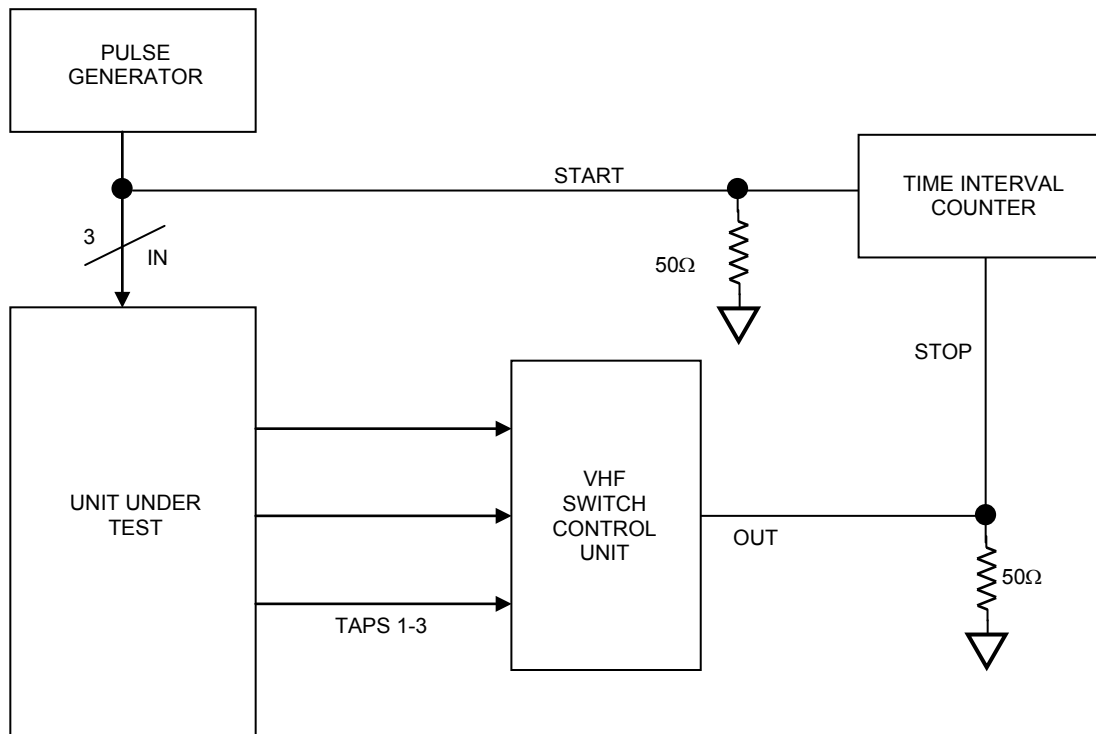

ABSOLUTE MAXIMUM RATINGS

| | |
|---|-------------------|
| Voltage Range on Any Pin Relative to Ground | -1.0V to +6.0V |
| Short Circuit Output Current | 50mA for 1 second |
| Operating Temperature | -40°C to +85°C |
| Storage Temperature | -55°C to +125°C |
| Lead Temperature (soldering, 10 seconds) | +300°C |
| Soldering Temperature (reflow) | +260°C |

This is a stress rating only and functional operation of the device at these or any other conditions above those indicated in the operation sections of this specification is not implied. Exposure to absolute maximum rating conditions for extended periods of time may affect reliability.

DC ELECTRICAL CHARACTERISTICS

($V_{CC} = +5V \pm 5\%$, $T_A = -40^\circ C$ to $+85^\circ C$, unless otherwise noted.)

| PARAMETER | SYMBOL | CONDITIONS | MIN | TYP | MAX | UNITS | NOTES |
|---------------------------|----------|--|------|------|----------------|---------|-------|
| Supply Voltage | V_{CC} | | 4.75 | 5.00 | 5.25 | V | 1 |
| Active Current | I_{CC} | $V_{CC} = 5.25V$, period = 1 μs | | | 35 | mA | |
| High Level Input Voltage | V_{IH} | | 2.2 | | $V_{CC} + 0.5$ | V | 1 |
| Low Level Input Voltage | V_{IL} | | -0.5 | | 0.8 | V | 1 |
| Input Leakage | I_L | $0V \leq V_I \leq V_{CC}$ | -1.0 | | +1.0 | μA | |
| High Level Output Current | I_{CC} | $V_{CC} = 4.75V$, $V_{OH} = 4V$ | | | -1.0 | mA | 1 |
| Low Level Output Current | I_{CC} | $V_{CC} = 4.75V$, $V_{OL} = 0.5V$ | 12 | | | mA | 1 |

AC ELECTRICAL CHARACTERISTICS

($V_{CC} = +5V \pm 5\%$, $T_A = -40^\circ C$ to $+85^\circ C$, unless otherwise noted.)

| PARAMETER | SYMBOL | MIN | TYP | MAX | UNITS | NOTES |
|--------------------------|--------------------|----------------------|-----|-----|-------|-------|
| Period | t_{PERIOD} | 2 (t_{WI}) | | | ns | 2 |
| Input Pulse Width | t_{WI} | 100% of Tap Delay | | | ns | 2 |
| Input-to-Output Delay | t_{PLH}, t_{PHL} | See Table 1 | | ns | | |
| Output Rise or Fall Time | t_{OF}, t_{OR} | | 2.0 | 2.5 | ns | |
| Power-up Time | t_{PU} | | | 100 | ms | 3 |

CAPACITANCE

($T_A = +25^\circ C$, unless otherwise noted.)

| PARAMETER | SYMBOL | MIN | TYP | MAX | UNITS | NOTES |
|-------------------|----------|-----|-----|-----|-------|-------|
| Input Capacitance | C_{IN} | | | 10 | pF | |

TEST CONDITIONS

Ambient Temperature: $25^{\circ}\text{C} \pm 3^{\circ}\text{C}$

Supply Voltage (V_{CC}): $5.0\text{V} \pm 0.1\text{V}$

Input Pulse:

High: $3.0\text{V} \pm 0.1\text{V}$

Low: $0.0\text{V} \pm 0.1\text{V}$

Source Impedance: 50Ω Max.

Rise and Fall Time: 3.0ns Max. - Measured between 0.6V and 2.4V .

Pulse Width: 500ns

Pulse Period: $1\mu\text{s}$

Output Load Capacitance: 15pF

Output: Each output is loaded with the equivalent of one 74F04 input gate.

Data is measured at the 1.5V level on the rising and falling edges.

Note: The above conditions are for test only and do not restrict the devices under other data sheet conditions.

NOTES:

1. All voltages are referenced to ground.
2. Pulse width and duty cycle specifications may be exceeded; however, accuracy will be application sensitive with respect to decoupling, layout, etc.
3. Power-up time is the time from the application of power to the time stable delays are being produced at the output.

TIMING DIAGRAM

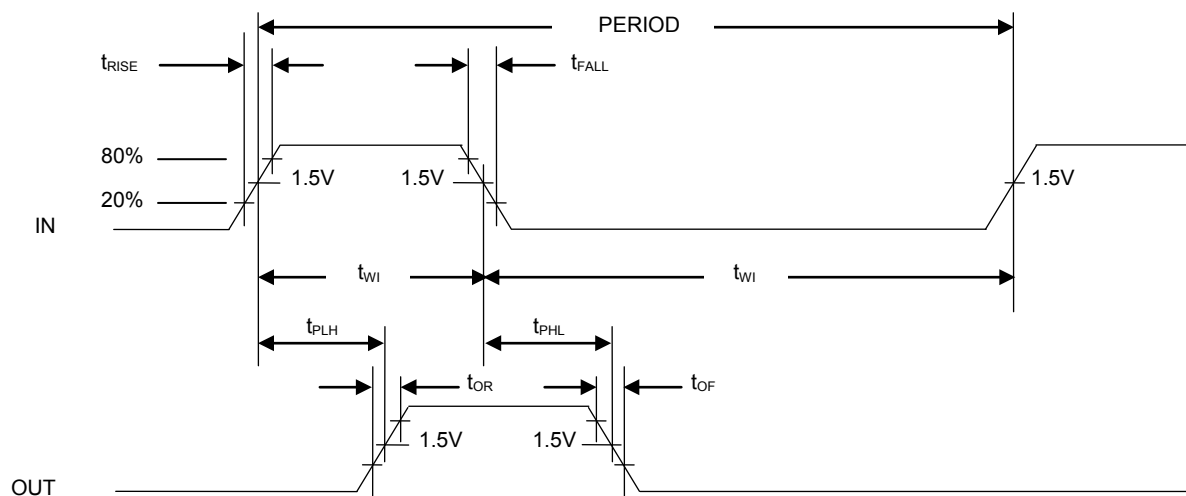

TERMINOLOGY

Period: The time elapsed between the leading edge of the first pulse and the leading edge of the following pulse.

t_{WI} (Pulse Width): The elapsed time on the pulse between the 1.5-volt point on the leading edge and the 1.5-volt point on the trailing edge or the 1.5-volt point on the trailing edge and the 1.5-volt point on the leading edge.

t_{RISE} (Input Rise Time): The elapsed time between the 20% and the 80% point on the leading edge of the input pulse.

t_{FALL} (Input Fall Time): The elapsed time between the 80% and the 20% point on the trailing edge on the input pulse.

t_{PLH} (Time Delay, Rising): The elapsed time between the 1.5-volt point on the leading edge of the input pulse and the 1.5-volt point on the leading edge of the output pulse.

t_{PHL} (Time Delay, Falling): The elapsed time between the 1.5-volt point on the falling edge of the input pulse and the 1.5-volt point on the falling edge of the output pulse.

ORDERING INFORMATION

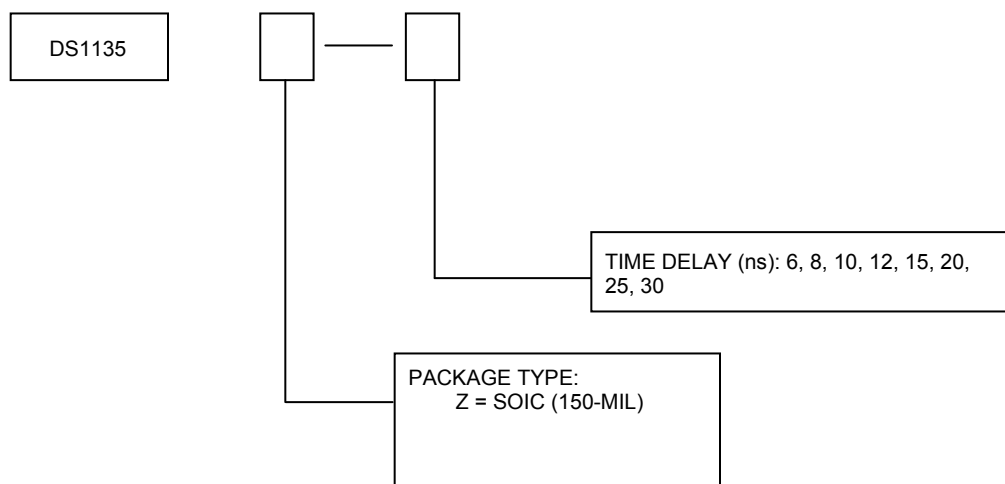

PACKAGE INFORMATION

For the latest package outline information and land patterns (footprints), go to www.maximintegrated.com/packages. Note that a "+", "#", or "-" in the package code indicates RoHS status only. Package drawings may show a different suffix character, but the drawing pertains to the package regardless of RoHS status.

| PACKAGE TYPE | PACKAGE CODE | OUTLINE NO. | LAND PATTERN NO. |
|--------------|--------------|-------------------------|-------------------------|
| 8 SO | S8+2 | 21-0041 | 90-0096 |

REVISION HISTORY

| REVISION DATE | DESCRIPTION | PAGES CHANGED |
|----------------------|--|----------------------|
| 8/12 | Removed the DIP and μ SOP packages; updated the <i>Absolute Maximum Ratings section</i> ; added the <i>Package Information section</i> | 1, 2, 4, 6 |

Maxim cannot assume responsibility for use of any circuitry other than circuitry entirely embodied in a Maxim product. No circuit patent licenses are implied. Maxim reserves the right to change the circuitry and specifications without notice at any time. The parametric values (min and max limits) shown in the Electrical Characteristics table are guaranteed. Other parametric values quoted in this data sheet are provided for guidance.

Maxim Integrated 160 Rio Robles, San Jose, CA 95134 USA 1-408-601-1000

Данный компонент на территории Российской Федерации

Вы можете приобрести в компании MosChip.

Для оперативного оформления запроса Вам необходимо перейти по данной ссылке:

<http://moschip.ru/get-element>

Вы можете разместить у нас заказ для любого Вашего проекта, будь то серийное производство или разработка единичного прибора.

В нашем ассортименте представлены ведущие мировые производители активных и пассивных электронных компонентов.

Нашей специализацией является поставка электронной компонентной базы двойного назначения, продукции таких производителей как XILINX, Intel (ex.ALTERA), Vicor, Microchip, Texas Instruments, Analog Devices, Mini-Circuits, Amphenol, Glenair.

Сотрудничество с глобальными дистрибьюторами электронных компонентов, предоставляет возможность заказывать и получать с международных складов практически любой перечень компонентов в оптимальные для Вас сроки.

На всех этапах разработки и производства наши партнеры могут получить квалифицированную поддержку опытных инженеров.

Система менеджмента качества компании отвечает требованиям в соответствии с ГОСТ Р ИСО 9001, ГОСТ РВ 0015-002 и ЭС РД 009

Офис по работе с юридическими лицами:

105318, г.Москва, ул.Щербаковская д.3, офис 1107, 1118, ДЦ «Щербаковский»

Телефон: +7 495 668-12-70 (многоканальный)

Факс: +7 495 668-12-70 (доб.304)

E-mail: info@moschip.ru

Skype отдела продаж:

moschip.ru

moschip.ru_4

moschip.ru_6

moschip.ru_9