

## Preliminary Product Specification

### 100GHz Ultra-High Speed Balanced Photodetector

#### BPDV412xRy-WF-zz

#### PRODUCT FEATURES

- Ultra-high bandwidth of >100GHz
- Based on a waveguide-integrated photodetector chip
- Excellent uniformity of photodiodes
- Integrated termination
- C-band performance
- SMF-28 optical input
- Temperature: 0°C to +75°C
- Supply voltage: +3.5/-3.5 V
- F16 package with W1-connector®
- Available as dual-pair or quad-set
- Offered also as 90GHz version



#### APPLICATIONS

- Coherent Test & Measurement Systems
- Next Generation DWDM Networks
- Transmission Systems with >1Tb/s data-rate
- Research and Development
- Detection of up to 160 Gbaud x-QAM signals

The BPDV412x balanced photodetector is a compact module consisting of two optimized 100 GHz waveguide-integrated photodiodes on a single chip. As a single device, this configuration ensures excellent uniformity of the paired photodiodes performance; biasing is achieved via an integrated biasing network. Due to the optimized design of waveguide and Photodiode, even at high optical power, a linear frequency response can be guaranteed. The integrated termination allows an excellent match of the electrical output signal. Custom configurations are available, such as BPDV matched pairs, and quad sets, including connector customization and fiber matching to enable coherent detection. A 90 GHz version of this module is also available upon request.

### I Ordering Information

**BPDV412xRy-WF-zz**

- x:     0: f3dB > 90 GHz  
       1: f3dB > 100 GHz
  
- Ry:    R = single balanced detector  
       RM = matched pair of balanced detectors  
       RQ = matched quad-set of balanced detectors
  
- zz:    SA = SC/APC  
       other options upon request

### II Block Diagram

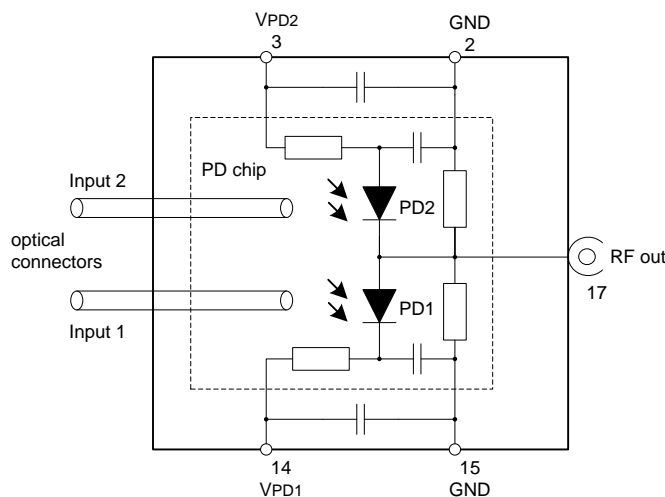

Figure 1 Block Diagram of BPDV412xRy-WF-zz

### III Absolute Maximum Ratings

Parameter	Symbol	Condition	Min.	Typ.	Max.	Unit
Photodiode bias voltage	$V_{PD1}$		0		4	V
	$V_{PD2}$		-4		0	
Maximum average optical input power	$P_{OPT}$	continuous wave (CW)			16	dBm
Electro static discharge	$V_{ESD}$	C=100 pF, R= 1.5 kΩ HBM	-250		250	V

## IV Environmental Conditions

Parameter	Symbol	Condition	Min.	Typ.	Max.	Unit
Storage temperature	T <sub>storage</sub>	non condensing	-40		+85	°C
Operating case temperature range	T <sub>CASE</sub>		0		+75	°C
Relative humidity range	RH	non condensing	5		85	%

## V Operating Conditions

Parameter	Symbol	Condition	Min.	Typ.	Max.	Unit
Operating wavelength range	$\lambda$		1525		1570	nm
Average optical input power range	P <sub>OPT</sub>				13	dBm
Photodiode bias voltage	V <sub>PD1</sub> V <sub>PD2</sub>		2.5 -3.8	3.3 -3.3	3.8 -2.5	V

## VI Electro-Optical Specifications<sup>1</sup>

Parameter	Symbol	Condition	Min.	Typ.	Max.	Unit
Photodiode DC responsivity	R	optimum polarization	0.23	0.27		A/W
Imbalance of responsivity	Imb	$Imb =  10 \cdot \log_{10}(R_{PD1}/R_{PD2}) $		0.15	0.5	
Polarization dependent loss	PDL			0.75	0.95	dB
Optical return loss	ORL		27			dB
3dB cut-off frequency (BPDV4121)	f <sub>3dB</sub>		100	105		GHz
3dB cut-off frequency (BPDV4120)	f <sub>3dB</sub>		90	95		GHz
Output Reflection Coefficient	S <sub>22</sub>	0...35 GHz		-10	-9	dB
		35...50 GHz		-8	-7	
		50...67 GHz		-5	-4.0	
CMRR		$CMRR = 20 \cdot \log_{10}  (S_{21} - S_{31}) / (S_{21} + S_{31}) $ 0...67 GHz		14		dB
Photodiode dark current	I <sub>dark</sub>			10	200	nA
Skew				1.0		ps
Skew (inter module)				4		ps
Notes:						
1 $\lambda = 1550$ nm, V <sub>PD</sub> = ± 3.3 V, T = 25°C, P <sub>OPT</sub> = +3 dBm						

## VII Typical Performance

Frequency response

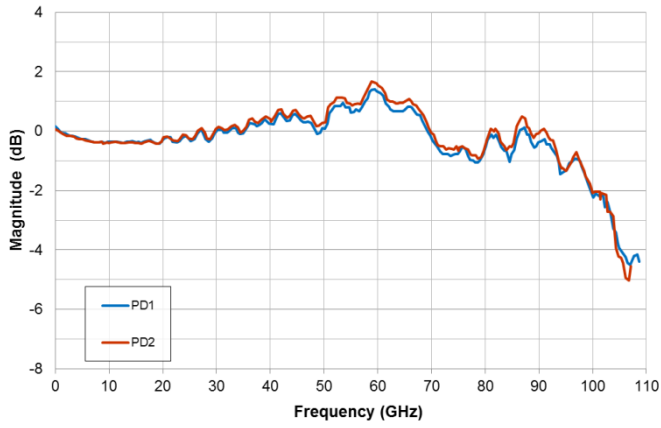

Figure 2 Frequency response of the BPDV4121R measured with Heterodyne measurement setup

## VIII Mechanical Specifications

All dimensions are in mm.

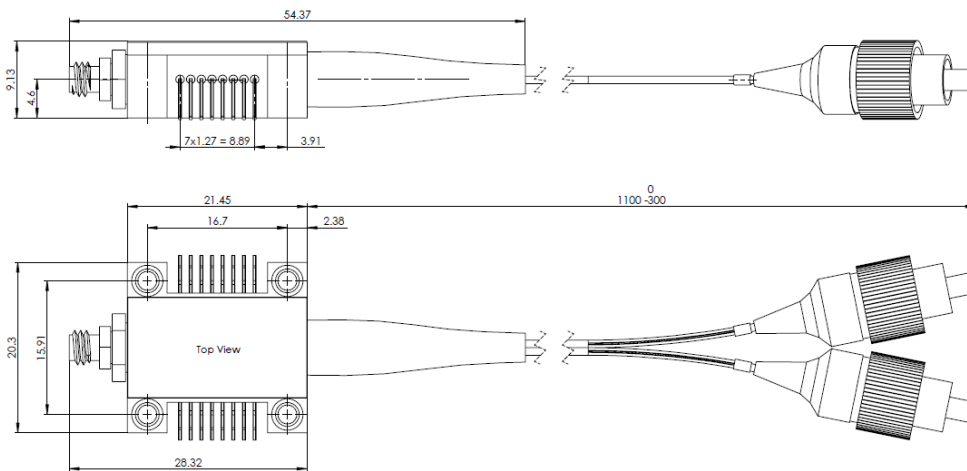

Figure 3. Mechanical dimensions of BPDV412xRy-WF-zz

## IX General Notices



### Notice

Stresses greater than those listed under “Absolute Maximum Ratings” may cause permanent damage to the device. This is a stress rating only and functional operation of the device at these or any other conditions above those indicated in the operations section for extended periods of time may affect reliability.

The inherent design of this component causes it to be sensitive to electrostatic discharge (ESD). To prevent ESD-induced damage and/or degradation to equipment, take normal ESD precautions when handling this product

## X Notes

Any trademarks used in this document are properties of their respective owners. Finisar Corporation reserves the right to make changes without notice.

## XI Revision History

Document Number: **TBD**

Revision	Date	Description
A1	2017-03-10	Initial Release.
A2	2017-03-17	Updated specifications

## XII For More Information

Finisar Corporation  
 1389 Moffett Park Drive  
 Sunnyvale, CA 94089-1133  
 Tel: +1-408-548-1000  
 Fax: +1-408-541-6138  
[high-speed-detectors@finisar.com](mailto:high-speed-detectors@finisar.com)  
[sales@finisar.com](mailto:sales@finisar.com)  
[www.finisar.com](http://www.finisar.com)

## Данный компонент на территории Российской Федерации

### Вы можете приобрести в компании MosChip.

Для оперативного оформления запроса Вам необходимо перейти по данной ссылке:

<http://moschip.ru/get-element>

Вы можете разместить у нас заказ для любого Вашего проекта, будь то серийное производство или разработка единичного прибора.

В нашем ассортименте представлены ведущие мировые производители активных и пассивных электронных компонентов.

Нашей специализацией является поставка электронной компонентной базы двойного назначения, продукции таких производителей как XILINX, Intel (ex.ALTERA), Vicor, Microchip, Texas Instruments, Analog Devices, Mini-Circuits, Amphenol, Glenair.

Сотрудничество с глобальными дистрибьюторами электронных компонентов, предоставляет возможность заказывать и получать с международных складов практически любой перечень компонентов в оптимальные для Вас сроки.

На всех этапах разработки и производства наши партнеры могут получить квалифицированную поддержку опытных инженеров.

Система менеджмента качества компании отвечает требованиям в соответствии с ГОСТ Р ИСО 9001, ГОСТ РВ 0015-002 и ЭС РД 009

### Офис по работе с юридическими лицами:

105318, г.Москва, ул.Щербаковская д.3, офис 1107, 1118, ДЦ «Щербаковский»

Телефон: +7 495 668-12-70 (многоканальный)

Факс: +7 495 668-12-70 (доб.304)

E-mail: [info@moschip.ru](mailto:info@moschip.ru)

Skype отдела продаж:

moschip.ru

moschip.ru\_4

moschip.ru\_6

moschip.ru\_9