

SYNCHRONOUS RECTIFIER CONTROLLER

Description

The ZXGD3101 is intended to drive MOSFETS configured as ideal diode replacements. The device is comprised of a differential amplifier detector stage and high current driver. The detector monitors the reverse voltage of the MOSFET such that if body diode conduction occurs a positive voltage is applied to the MOSFET's Gate pin.

Once the positive voltage is applied to the Gate the MOSFET switches on allowing reverse current flow. The detectors' output voltage is then proportional to the MOSFET Drain-Source reverse voltage drop and this is applied to the Gate via the driver. This action provides a rapid turn off as current decays.

Application

- Flyback Converters in:
 - Adaptors
 - LCD Monitors
 - Server PSU's
 - Set Top Boxes
- LLC Converter in:
 - High Power Adaptors
 - LCD TV
 - Street Lighting

Refer to documents: AN54, AN69, DN90, DN91 and DN94 available from the website

Features

- Turn-off propagation delay 15ns and turn-off time 20ns.
- Suitable for Discontinuous Mode (DCM), Critical Conduction Mode (CrCM) and Continuous Mode (CCM) operation
- Compliant with Energy Star V2.0 and European Code of Conduct V3
- Halogen Free part
- 5-15V V_{cc} range

Mechanical Data

- Case: SO-8
- Marking Information: See Page 13

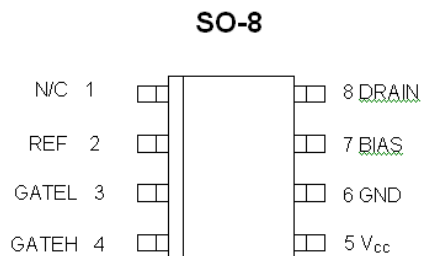

Pin out details

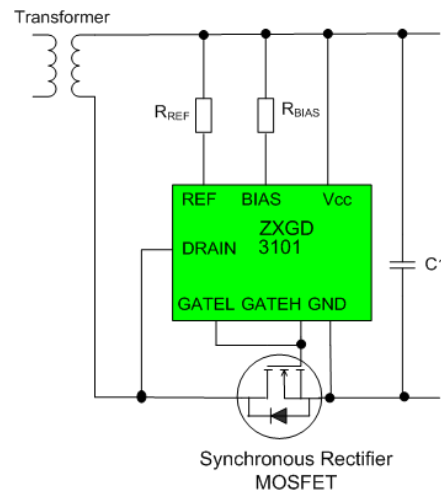

Ordering Information

Product	Status	Package	Marking	Reel size (inches)	Tape width (mm)	Quantity per reel
ZXGD3101N8TC	Active	SO-8	ZXGD3101	13	12	2500

SYNCHRONOUS RECTIFIER CONTROLLER

Maximum Ratings

Parameter	Symbol	Limit	Unit
Supply voltage (Note 1)	V_{CC}	15	V
Continuous Drain pin voltage (Note 1)	V_D	-3 to 180	V
GATEH and GATEL output Voltage (Note 1)	V_G	-3 to $V_{CC} + 3$	V
Driver peak source current	I_{SOURCE}	4	A
Driver peak sink current	I_{SINK}	7	A
Reference current	I_{REF}	25	mA
Bias voltage	V_{BIAS}	V_{CC}	V
Bias current	I_{BIAS}	100	mA
Power dissipation at $T_A = 25^\circ\text{C}$	P_D	490	mW
Operating junction temperature	T_J	-40 to +150	$^\circ\text{C}$
Storage temperature	T_{STG}	-50 to +150	$^\circ\text{C}$

Thermal Characteristics

Parameter	Symbol	Value	Unit
Junction to ambient (Note 2)	$R_{\theta JA}$	255	$^\circ\text{C/W}$
Junction to lead (Note 3)	$R_{\theta LA}$	120	$^\circ\text{C/W}$

ESD Rating

Model	Rating	Unit
Human Body	4000	V
Machine	400	V

- Notes:
1. All voltages are relative to GND pin
 2. Mounted on minimum 1oz weight copper on FR4 PCB in still air conditions.
 3. Output Drivers - Junction to solder point at end of the lead 5 and 6

SYNCHRONOUS RECTIFIER CONTROLLER

Electrical Characteristics @ $T_A = 25^\circ\text{C}$, $V_{CC} = 10\text{V}$, $R_{BIAS} = 1.8\text{k}\Omega$, $R_{REF} = 3\text{k}\Omega$

Parameter	Symbol	Conditions	Min.	Typ.	Max.	Unit
Input and supply characteristics						
Operating current	I_{OP}	$V_{DRAIN} \leq -200\text{mV}$	-	3	-	mA
		$V_{DRAIN} \geq 0\text{V}$	-	8	-	
Gate Driver						
Turn-off Threshold Voltage(Note 4)	V_T	$V_G = 1\text{V}$, (Note 5)	-45	-16	0	mV
GATE output voltage (Note 4)	$V_{G(off)}$	$V_{DRAIN} \geq 0\text{V}$, (Note 5)	-	0.6	1	V
	V_G	$V_{DRAIN} = -60\text{mV}$, (Note 6)	5.0	7.5	-	
		$V_{DRAIN} = -80\text{mV}$, (Note 6)	7.0	8.5	-	
		$V_{DRAIN} = -100\text{mV}$, (Note 6)	8.4	9	-	
		$V_{DRAIN} \leq -140\text{mV}$, (Note 6)	9.2	9.4	-	
		$V_{DRAIN} \leq -200\text{mV}$, (Note 6)	9.3	9.5	-	
GATEH peak source current	I_{SOURCE}	$V_{GH} = 1\text{V}$		2.5	-	A
GATEL peak sink current	I_{SINK}	$V_{GL} = 5\text{V}$		2.5	-	A
Turn on Propagation delay	t_{d1}	$C_L = 2.2\text{nF}$, (Notes 6 and 7)		525		ns
Turn off Propagation delay	t_{d2}			15		ns
Gate rise time	t_r			305		ns
Gate fall time	t_f			20		ns

- Notes:
4. GATEH connected to GATEL
 5. $R_H = 100\text{k}\Omega$, $R_L = \text{O/C}$
 6. $R_L = 100\text{k}\Omega$, $R_H = \text{O/C}$
 7. Refer to Fig 6: test circuit and Fig 7: timing diagram on Page 12

SYNCHRONOUS RECTIFIER CONTROLLER

Schematic Symbol and Pin Out Details

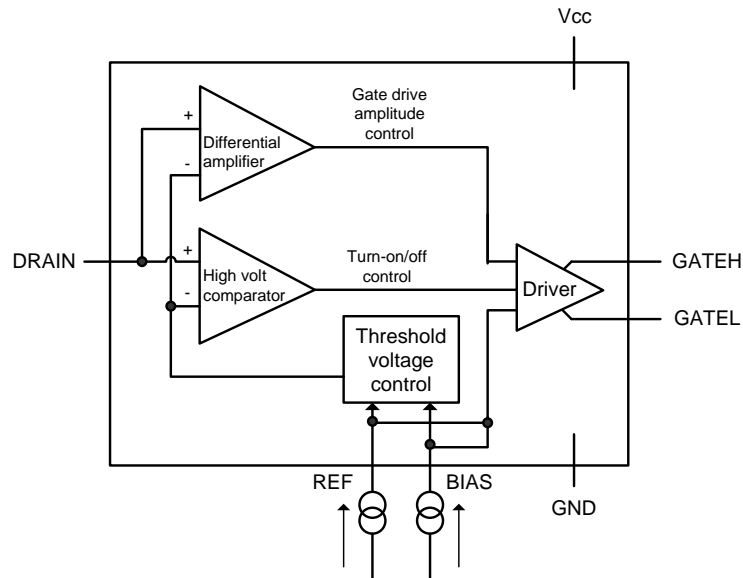

Pin No.	Symbol	Description and function
1	NC	No connection This pin can be connected to GND
2	REF	Reference This pin is connected to V_{CC} via resistor, R_{REF} . R_{REF} should be selected to source approximately 3mA into this pin. (Note 8)
3	GATEL	Gate turn off This pin sinks current, I_{SINK} , from the synchronous MOSFET Gate.
4	GATEH	Gate turn on This pin sources current, I_{SOURCE} , to the synchronous MOSFET Gate.
5	V_{CC}	Power Supply This is the supply pin. It is recommended to decouple this point to ground closely with a ceramic capacitor.
6	GND	Ground This is the ground reference point. Connect to the synchronous MOSFET Source terminal.
7	BIAS	Bias This pin is connected to V_{CC} via resistor, R_{BIAS} . R_{BIAS} should be selected to source 1.6 times I_{REF} into this pin. (Note 9)
8	DRAIN	Drain connection This pin connects directly to the synchronous MOSFET Drain terminal.

Notes: 8. REF pin should be assumed to be at GND +0.7V.
9. BIAS pin should be assumed to be at GND +0.3V.

SYNCHRONOUS RECTIFIER CONTROLLER

Operation

Normal Operation

The operation of the device is described step-by-step with reference to the timing diagram below.

1. The detector monitors the MOSFET Drain-Source voltage.
2. When, due to transformer action, the MOSFET body diode is forced to conduct there is approximately -0.6V on the Drain pin.
3. The detector outputs a positive voltage with respect to ground, this voltage is then fed to the MOSFET driver stage and current is sourced out of the GATEH pin.
4. The current out of the GATEH pin is sourced into the synchronous MOSFET Gate to turn the device on.
5. The GATEH output voltage is now proportional to the Drain-Source voltage drop across the MOSFET due to the current flowing through the MOSFET.
6. MOSFET conduction continues until the drain current reaches zero.
7. At zero current the detector output voltage is zero and the synchronous MOSFET Gate voltage is pulled low by the GATEL, turning the device off.

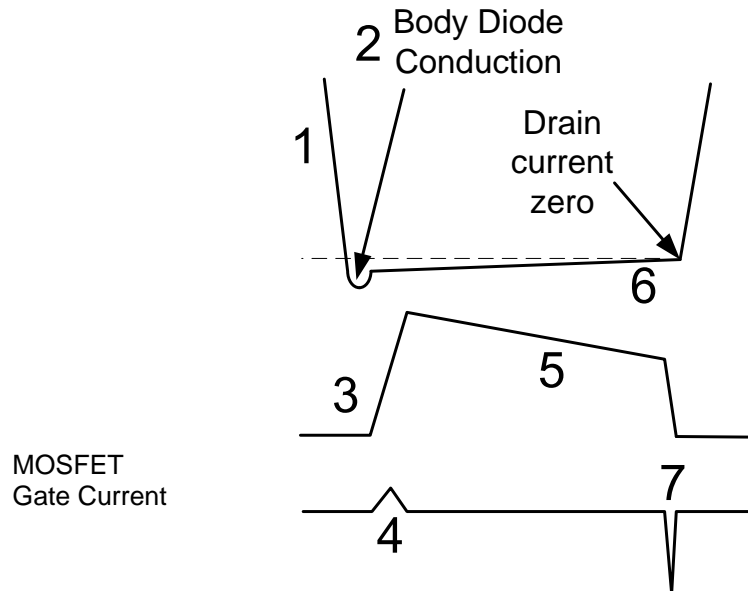

ZXGD3101N8

SYNCHRONOUS RECTIFIER CONTROLLER

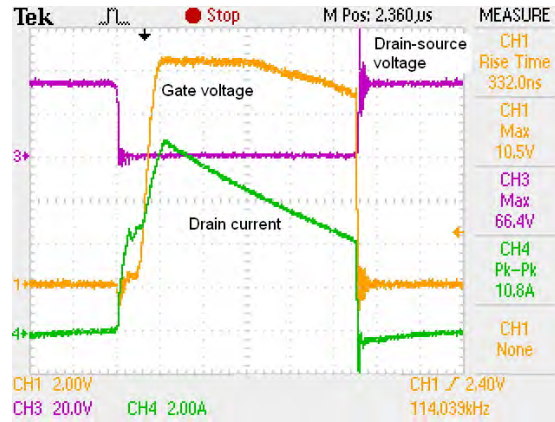

1a) Continuous Conduction Mode (CCM)

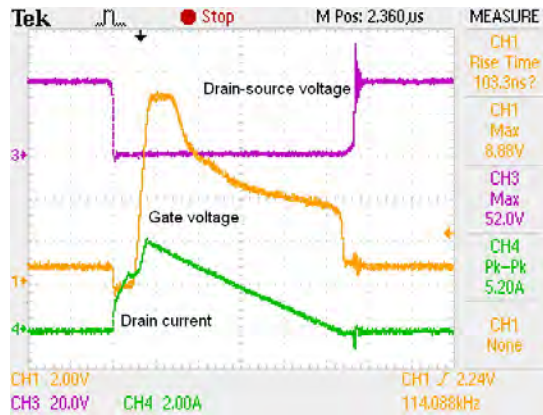

1b) Critical Conduction Mode (CrCM)

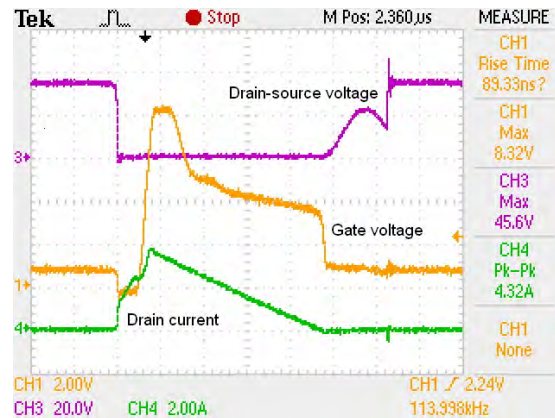

1c) Discontinuous Conduction Mode (DCM)

Figure 1: Typical waveforms

Typical Characteristics

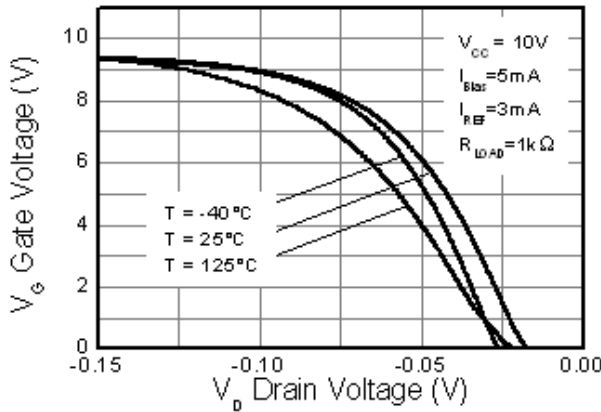

Transfer Characteristic

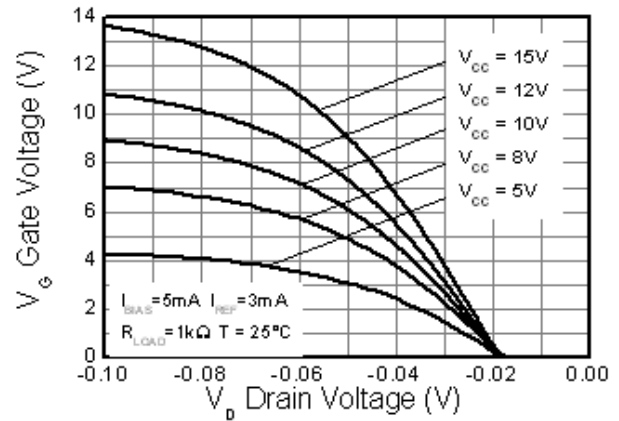

Transfer Characteristic

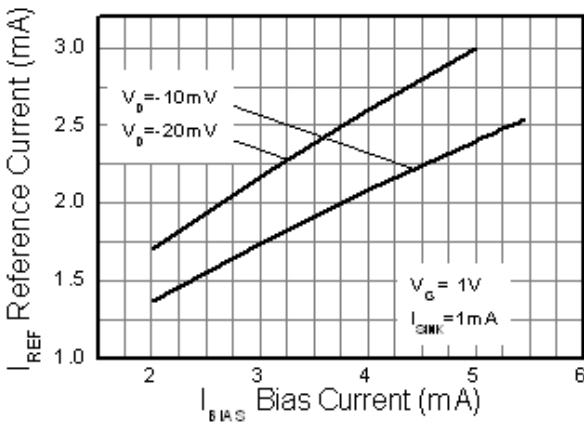

Bias Current vs Reference Current

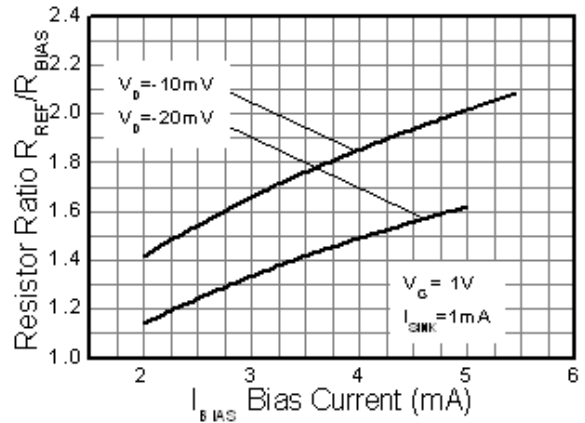

Bias Resistor vs Reference Resistor

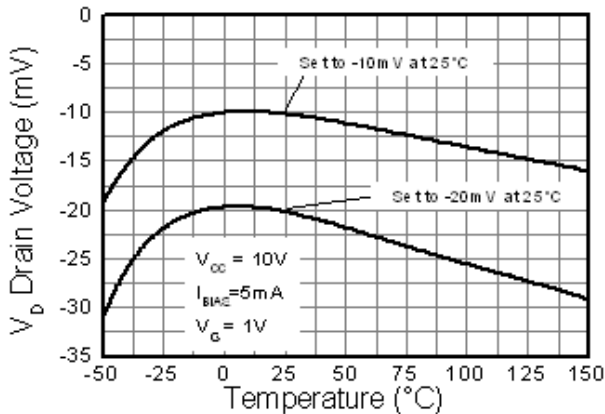

Drain Sense Voltage vs Temperature

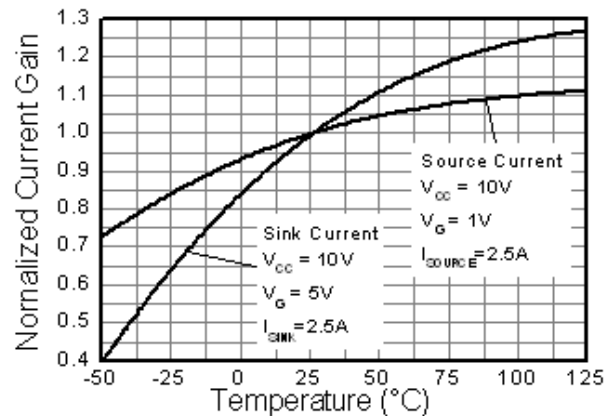

Output Current vs Temperature

SYNCHRONOUS RECTIFIER CONTROLLER

Typical Characteristics

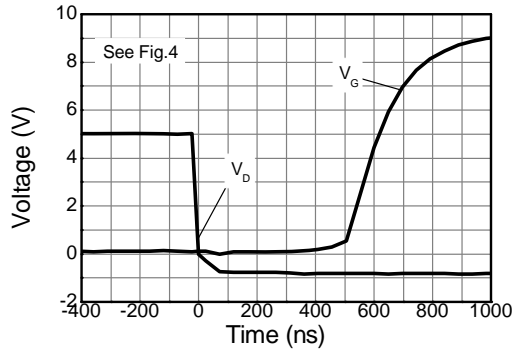

Switch On Speed

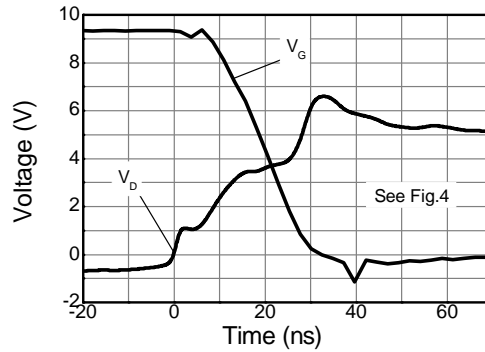

Switch Off Speed

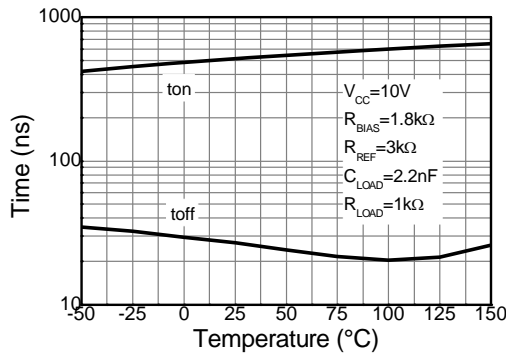

Switching vs Temperature

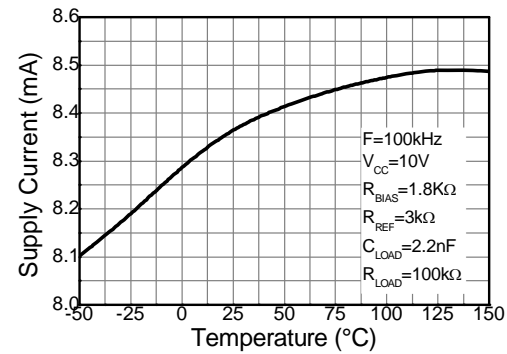

Supply Current vs Temperature

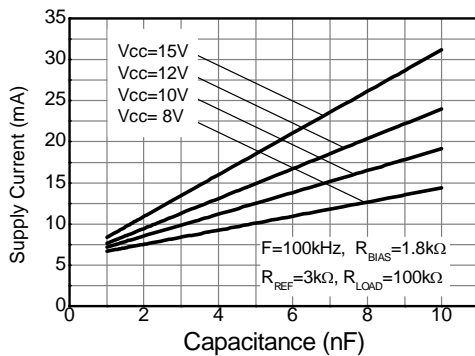

Supply Current vs Capacitive Load

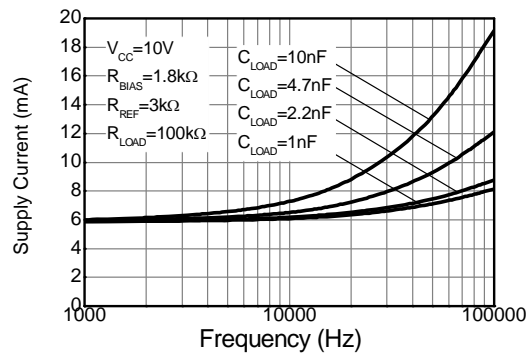

Supply Current vs Frequency

SYNCHRONOUS RECTIFIER CONTROLLER

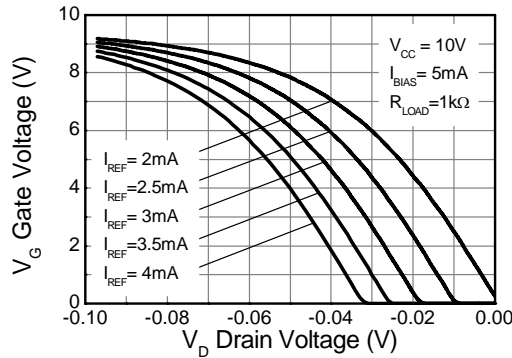

Transfer Characteristic

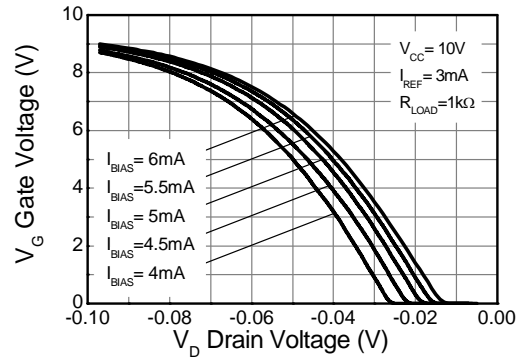

Transfer Characteristic

Component Selection

It is advisable to decouple the ZXGD3101 closely to V_{CC} and ground due to the possibility of high peak gate currents with C1 in Figure 2.

The proper selection of external resistors R_{REF} and R_{BIAS} is important to the optimum device operation. Select a value for resistor R_{REF} to give a reference current, I_{REF} , of ~3mA. The value of R_{BIAS} must then be 0.6 times the value of R_{REF} giving a bias current, I_{BIAS} , of ~1.6 times I_{REF} . This provides a recommended typical offset voltage of ~20mV.

External gate resistors are optional. They can be inserted to control the rise times which may help with EMI issues, power supply consumption issues or dissipation within the part.

$$R_{REF} = (V_{CC} - 0.7V) / 0.003$$

$$R_{BIAS} = (V_{CC} - 0.3V) / 0.005$$

Layout considerations

The Gate pins should be as close to the MOSFET Gate as possible. Also the ground return loop should be as short as possible. The decoupling capacitor should be close to the V_{CC} and Ground pin, and should be a X7R type.

For more detailed information refer to application note AN54..

SYNCHRONOUS RECTIFIER CONTROLLER

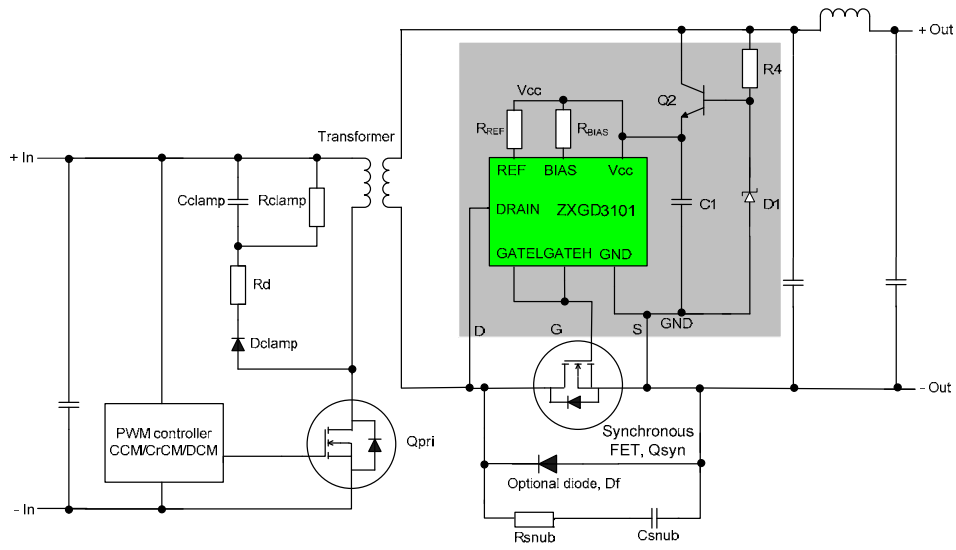

Figure 2 Example connection for low side synchronous rectification

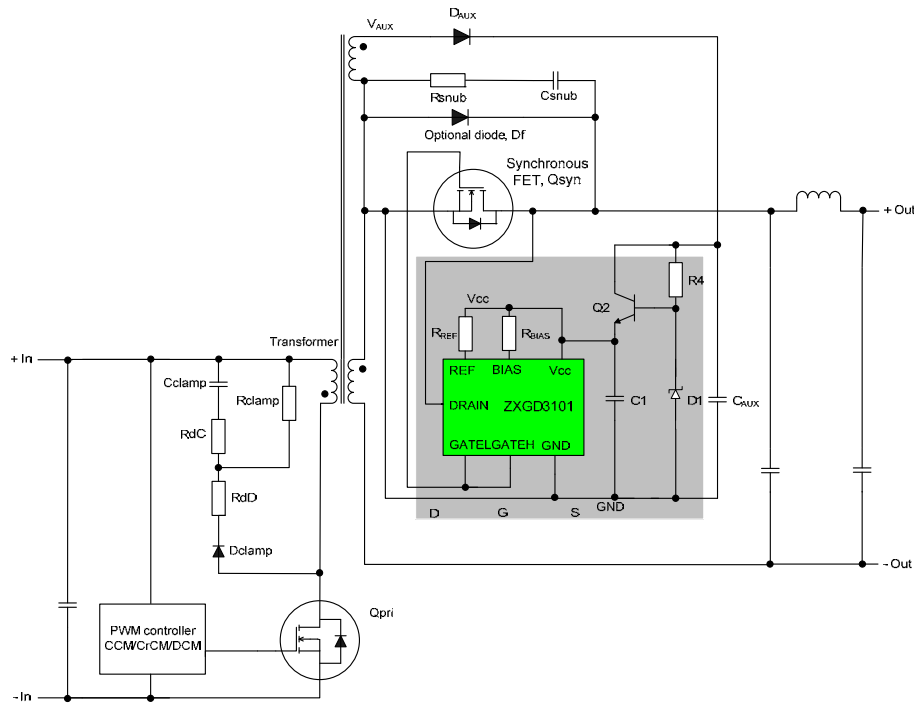

Figure 3: Example connection for high side synchronous rectification

ZXGD3101N8

SYNCHRONOUS RECTIFIER CONTROLLER

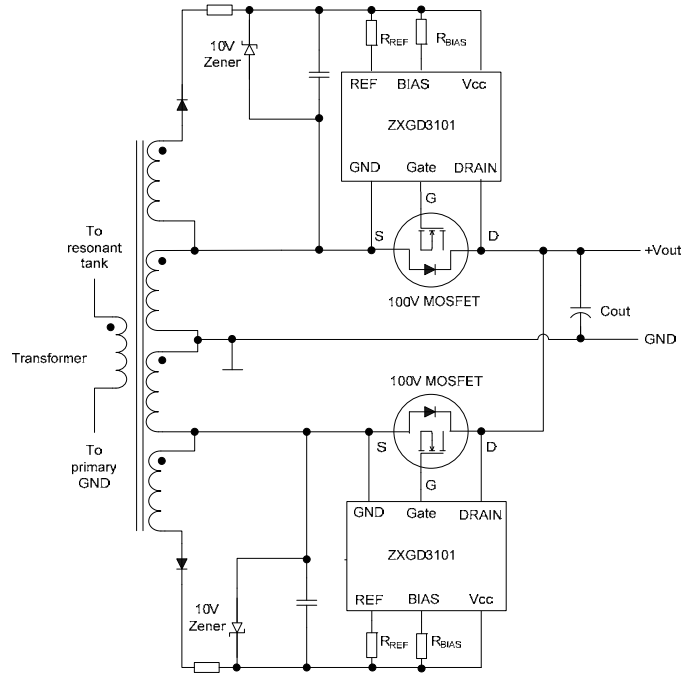

Figure 4: Example connections for LLC converter

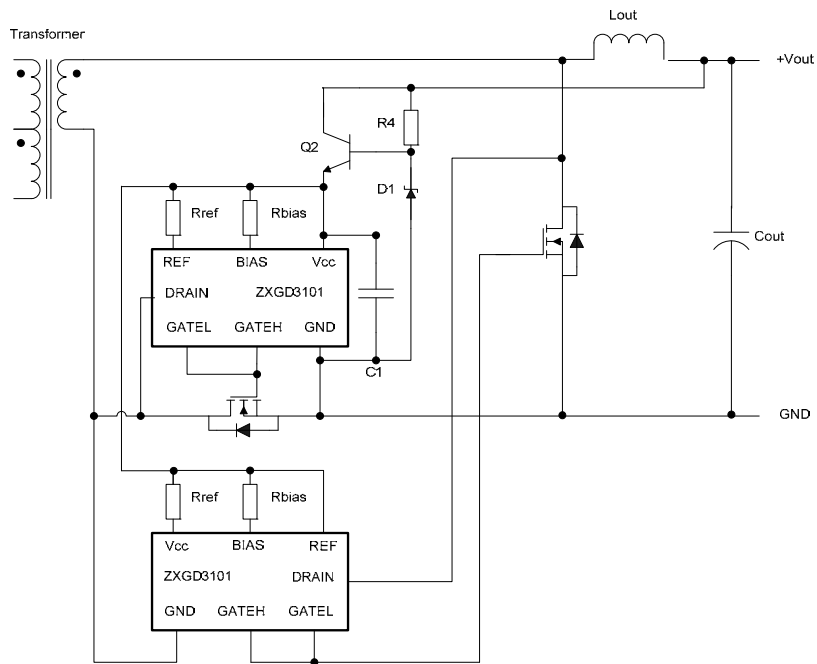

Figure 5: Example connections for Forward converter

ZXGD3101N8

SYNCHRONOUS RECTIFIER CONTROLLER

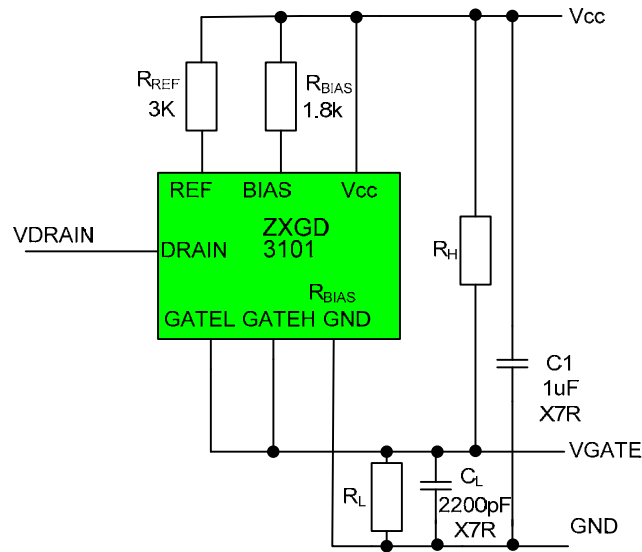
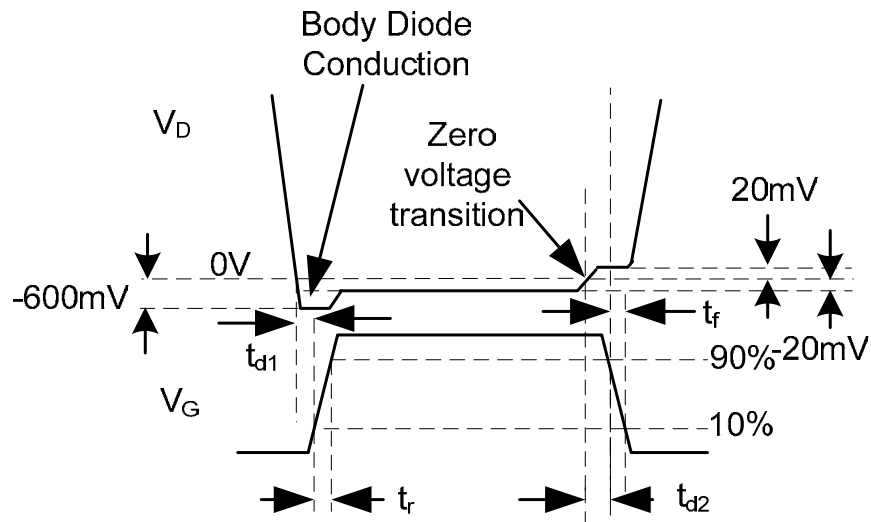

Figure 6: Test circuit



NOTE GATEH AND GATEL ARE CONNECTED

Figure 7: Timing Diagram

SYNCHRONOUS RECTIFIER CONTROLLER

Package Outline and Dimensions

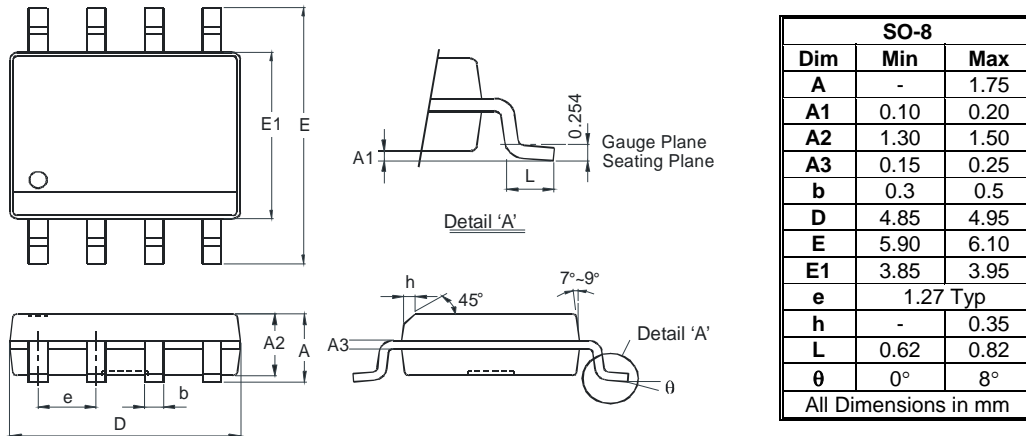

Suggested Pad Layout

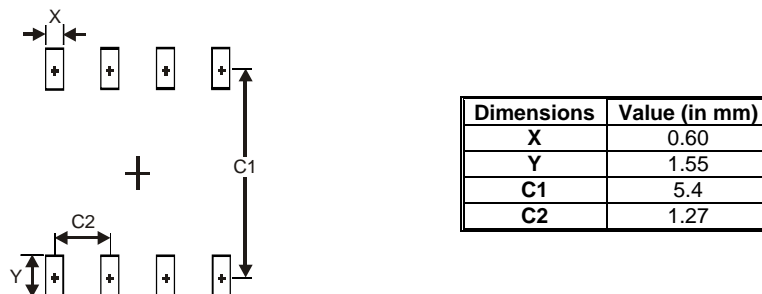

Marking Information

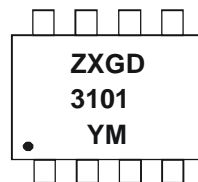

ZXGD3101 = Product Type Marking Code
 YM = Date Code Marking
 Y = Year (ex. W = 2009)
 M = Month (ex. 9 = September)

Date Code Key

Year	2009	2010	2011	2012	2013	2014	2015
Code	W	X	Y	Z	A	B	C

Month	Jan	Feb	Mar	Apr	May	Jun	Jul	Aug	Sep	Oct	Nov	Dec
Code	1	2	3	4	5	6	7	8	9	O	N	D

SYNCHRONOUS RECTIFIER CONTROLLER

IMPORTANT NOTICE

DIODES INCORPORATED MAKES NO WARRANTY OF ANY KIND, EXPRESS OR IMPLIED, WITH REGARDS TO THIS DOCUMENT, INCLUDING, BUT NOT LIMITED TO, THE IMPLIED WARRANTIES OF MERCHANTABILITY AND FITNESS FOR A PARTICULAR PURPOSE (AND THEIR EQUIVALENTS UNDER THE LAWS OF ANY JURISDICTION).

Diodes Incorporated and its subsidiaries reserve the right to make modifications, enhancements, improvements, corrections or other changes without further notice to this document and any product described herein. Diodes Incorporated does not assume any liability arising out of the application or use of this document or any product described herein; neither does Diodes Incorporated convey any license under its patent or trademark rights, nor the rights of others. Any Customer or user of this document or products described herein in such applications shall assume all risks of such use and will agree to hold Diodes Incorporated and all the companies whose products are represented on Diodes Incorporated website, harmless against all damages.

Diodes Incorporated does not warrant or accept any liability whatsoever in respect of any products purchased through unauthorized sales channel. Should Customers purchase or use Diodes Incorporated products for any unintended or unauthorized application, Customers shall indemnify and hold Diodes Incorporated and its representatives harmless against all claims, damages, expenses, and attorney fees arising out of, directly or indirectly, any claim of personal injury or death associated with such unintended or unauthorized application.

Products described herein may be covered by one or more United States, international or foreign patents pending. Product names and markings noted herein may also be covered by one or more United States, international or foreign trademarks.

LIFE SUPPORT

Diodes Incorporated products are specifically not authorized for use as critical components in life support devices or systems without the express written approval of the Chief Executive Officer of Diodes Incorporated. As used herein:

A. Life support devices or systems are devices or systems which:

1. are intended to implant into the body, or
2. support or sustain life and whose failure to perform when properly used in accordance with instructions for use provided in the labeling can be reasonably expected to result in significant injury to the user.

B. A critical component is any component in a life support device or system whose failure to perform can be reasonably expected to cause the failure of the life support device or to affect its safety or effectiveness.

Customers represent that they have all necessary expertise in the safety and regulatory ramifications of their life support devices or systems, and acknowledge and agree that they are solely responsible for all legal, regulatory and safety-related requirements concerning their products and any use of Diodes Incorporated products in such safety-critical, life support devices or systems, notwithstanding any devices- or systems-related information or support that may be provided by Diodes Incorporated. Further, Customers must fully indemnify Diodes Incorporated and its representatives against any damages arising out of the use of Diodes Incorporated products in such safety-critical, life support devices or systems.

Copyright © 2010, Diodes Incorporated

www.diodes.com

Данный компонент на территории Российской Федерации

Вы можете приобрести в компании MosChip.

Для оперативного оформления запроса Вам необходимо перейти по данной ссылке:

<http://moschip.ru/get-element>

Вы можете разместить у нас заказ для любого Вашего проекта, будь то серийное производство или разработка единичного прибора.

В нашем ассортименте представлены ведущие мировые производители активных и пассивных электронных компонентов.

Нашей специализацией является поставка электронной компонентной базы двойного назначения, продукции таких производителей как XILINX, Intel (ex.ALTERA), Vicor, Microchip, Texas Instruments, Analog Devices, Mini-Circuits, Amphenol, Glenair.

Сотрудничество с глобальными дистрибьюторами электронных компонентов, предоставляет возможность заказывать и получать с международных складов практически любой перечень компонентов в оптимальные для Вас сроки.

На всех этапах разработки и производства наши партнеры могут получить квалифицированную поддержку опытных инженеров.

Система менеджмента качества компании отвечает требованиям в соответствии с ГОСТ Р ИСО 9001, ГОСТ РВ 0015-002 и ЭС РД 009

Офис по работе с юридическими лицами:

105318, г.Москва, ул.Щербаковская д.3, офис 1107, 1118, ДЦ «Щербаковский»

Телефон: +7 495 668-12-70 (многоканальный)

Факс: +7 495 668-12-70 (доб.304)

E-mail: info@moschip.ru

Skype отдела продаж:

moschip.ru

moschip.ru_4

moschip.ru_6

moschip.ru_9