

DIMENSIONS					
POSITION	A ±0.10	B <sup>+0.15</sup> / <sub>-0.05</sub>	C ±0.20	D ±0.23	E ±0.20
36	6	7.65	9.15	25.00	27.00
64	20	21.65	23.15	39.00	41.00
98	37	38.65	40.15	56.00	58.00
164	70	71.65	73.15	89.00	91.00

mat'l. code		N/A		surface 58		tolerance		projection		product family		EDGE CARD	
ltr		ecn no		dr		date		tolerances unless otherwise specified		title		PCI EXPRESS SMT TYPE GEN3 for SIOM	
A		T07-1031		S.Lin		03/28/07		.X ± 0.30		MM		5	
B		T07-1151		J.H		11/05/07		.XX ± 0.20		scale N/A		A	
C		ELX-DG-17423-1		ST		04/10/14		.XXX ± 0.10					
D		ELX-DG-17800-1		ST		05/28/14		dr Stone Li 05/28/15		FCI		sheet 1 of 4 size	
E		ELX-DG-21161-1		ST		05/28/15		engr Stone Li 05/28/15				10073228 A4	
								chr / 05/28/15					
								appd PeiMing Zheng 05/28/15				type CUSTOMER Drawing	
sheet index		revision sheet		E		E		E		E			
				1		2		3		4			

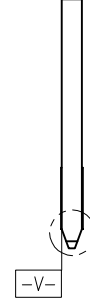

← I/O PANEL DIRECTION  
PRIMARY (COMPONENT) SIDE

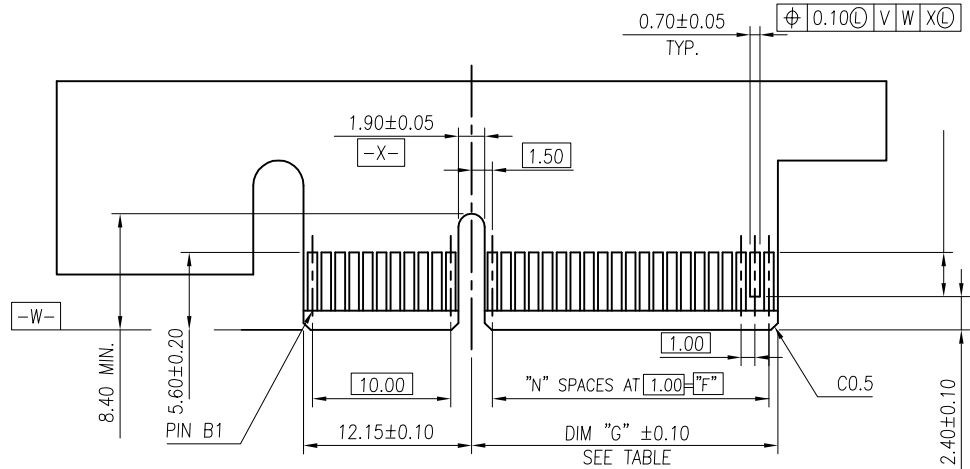
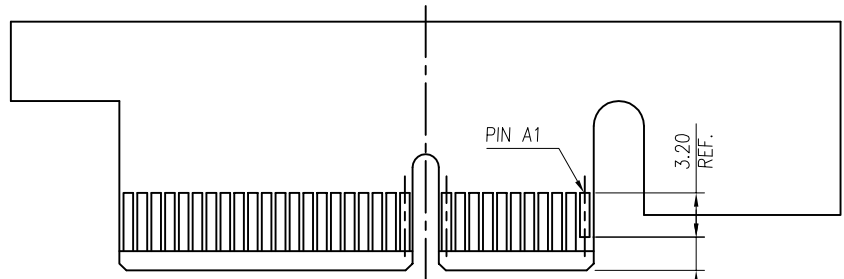

I/O PANEL DIRECTION →  
SECONDARY (SOLDER) SIDE

ADD-IN CARD EDGE-FINGER DIMENSIONS

# POS	REF.	N	DIM "G"	DIM "F"	"F"
36		6	8.15	6.00	B17
64		20	22.15	20.00	B31
98		37	39.15	37.00	B48
164		70	72.15	70.00	B81

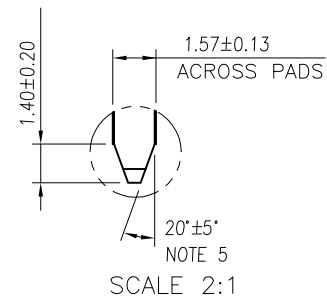

mat'l. code		surface 58		tolerance		projection		product family	
N/A		/		/		⊕		EDGE CARD	
ltr		ecn no		dr		date		title	
								PCI EXPRESS SMT TYPE GEN3 for SIOM	
								dwg no	
								sheet 2 of 4	
								size	
								A4	
								type	
								CUSTOMER Drawing	
sheet index		revision sheet							

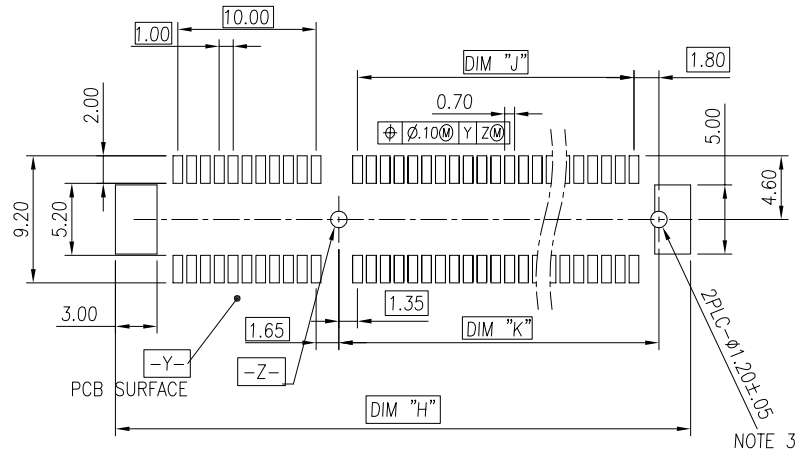

RECOMMENDED PCB LAYOUT, PAD TYPE

DIMENSIONS								
POSITION	A	B $\begin{smallmatrix} +0.15 \\ -0.05 \end{smallmatrix}$	C $\pm 0.20$	D $\pm 0.23$	E $\pm 0.20$	H $\pm 0.10$	J	K $\pm 0.10$
36	6.00	7.65	9.15	25.00	27.00	28.00	6.00	9.15
64	20.00	21.65	23.15	39.00	41.00	42.00	20.00	23.15
98	37.00	38.65	40.15	56.00	58.00	59.00	37.00	40.15
164	70.00	71.65	73.15	89.00	91.00	92.00	70.00	73.15

POSITION OF CAP

mat'l. code N/A		surface 58 / tolerance /		projection		product family EDGE CARD	
ltr		ecn no		dr		date	
tolerances unless otherwise specified		angles		Linear		title PCI EXPRESS SMT TYPE GEN3 for SIOM	
.X $\pm 0.30$		0°±2°		.XXX $\pm 0.10$		MM	
dr		Stone Li		05/28/15		scale N/A	
enrg		Stone Li		05/28/15		FCI	
chr		/		05/28/15		dwg no 10073228	
appd		PeiMing Zheng		05/28/15		sheet 3 of 4 size A4	
sheet index		revision sheet		type CUSTOMER Drawing		5	

NOTES:

1.MATERIAL:

HOUSING: HIGH TEMPERATURE NYLON, GLASS FILLED UL94V-0 RATED.

TERMINAL: COPPER ALLOY

PLATING: 50u" NICKEL UNDERPLATE ALL OVER  
CONTACT AREA PLATING - SEE PRODUCT NUMBER CODE

SOLDER TAIL: TIN - SEE PRODUCT NO. CODE  
100u" MIN. OVER 50u" NICKEL

METAL BOARD LOCKS: COPPER ALLOY

FINISH: 100u" TIN OVER 50u" NICKEL UNDERPLATE  
SEE PRODUCT NUMBER CODE

2.RoHS COMPATIBLE PRODUCT SPECIFICATIONS

a - PLATING:

- "LF" MEANS THE PRODUCT IS LEAD-FREE, 2um MINIMUM MATTE TIN OVER 1.27um MINIMUM NICKEL UNDERPLATE.

b - MANUFACTURING PROCESS COMPATIBILITY

- THE HOUSING WILL WITHSTAND EXPOSURE TO 260°C±5°C SOLDER BATH TEMPERATURE FOR 5 SECONDS IN A REFLOW SOLDER APPLICATION WITH A 1.6mm MIN THICK CIRCUIT BOARD.

PRODUCT NUMBER CODE

10073228 -x 0 x 0 x T □ □

HOUSING COLOR OPTIONS

1-BLACK

RESERVE

PACKAGING OPTIONS

T: TRAY PACKAGING WITHOUT CAP OR MYLAR

M: T&R PACKAGING WITH MYLAR (36P, 64P AND 98P ONLY)

"LF" FOR TERMINAL PLATING OPTION 0,1,2

POS OPTIONS

0-36  
1-64  
2-98  
3-164

RESERVE

TERMINAL PLATING OPTIONS

0-50u" Ni UNDERPLATE  
30u" Au CONTACT AREA  
100u" TIN TAIL AREA ----- COMPATIBLE RoHS  
1-50u" Ni UNDERPLATE  
15u" Au CONTACT AREA  
100u" TIN TAIL AREA ----- COMPATIBLE RoHS  
2-50u" Ni UNDERPLATE  
GOLD FLASH CONTACT AREA  
100u" TIN TAIL AREA ----- COMPATIBLE RoHS

mat'l. code		surface		tolerance		projection		product family	
N/A		/		58 /				EDGE CARD	
ltr	ecn no	dr	date	tolerances unless otherwise specified					
				angles	linear	.X ± 0.30			title
				0°±2°	XXX ± 0.20	scale N/A		PCI EXPRESS SMT TYPE GEN3 for SIOM	
				dr	Stone Li	05/28/15	FCI		dwg no
				enrg	Stone Li	05/28/15			sheet 4 of 4
				chr	/	05/28/15			size
				appd	PeiMing Zheng	05/28/15			A4
sheet index		revision sheet		type					
				CUSTOMER Drawing					

## Данный компонент на территории Российской Федерации

### Вы можете приобрести в компании MosChip.

Для оперативного оформления запроса Вам необходимо перейти по данной ссылке:

<http://moschip.ru/get-element>

Вы можете разместить у нас заказ для любого Вашего проекта, будь то серийное производство или разработка единичного прибора.

В нашем ассортименте представлены ведущие мировые производители активных и пассивных электронных компонентов.

Нашей специализацией является поставка электронной компонентной базы двойного назначения, продукции таких производителей как XILINX, Intel (ex.ALTERA), Vicor, Microchip, Texas Instruments, Analog Devices, Mini-Circuits, Amphenol, Glenair.

Сотрудничество с глобальными дистрибьюторами электронных компонентов, предоставляет возможность заказывать и получать с международных складов практически любой перечень компонентов в оптимальные для Вас сроки.

На всех этапах разработки и производства наши партнеры могут получить квалифицированную поддержку опытных инженеров.

Система менеджмента качества компании отвечает требованиям в соответствии с ГОСТ Р ИСО 9001, ГОСТ РВ 0015-002 и ЭС РД 009

### Офис по работе с юридическими лицами:

105318, г.Москва, ул.Щербаковская д.3, офис 1107, 1118, ДЦ «Щербаковский»

Телефон: +7 495 668-12-70 (многоканальный)

Факс: +7 495 668-12-70 (доб.304)

E-mail: [info@moschip.ru](mailto:info@moschip.ru)

Skype отдела продаж:

moschip.ru

moschip.ru\_4

moschip.ru\_6

moschip.ru\_9