

NOTES:

- 1 - SOLDERING INSTRUCTIONS: EXPOSURE TO HIGH TEMPERATURES SHOULD BE KEPT AT A MINIMUM. HONEYWELL RECOMMENDS AN INFRARED REFLOW PROCESS WITH PEAK TEMPERATURES NOT EXCEEDING 245°C FOR 10 SECONDS MAXIMUM. DO NOT WAVE SOLDER THIS PRODUCT, AS THIS PROCESS MAY NEGATIVELY AFFECT THE SENSOR'S PERFORMANCE AND RELIABILITY. SUBJECTING THESE PRODUCTS TO WAVE SOLDERING WILL VOID HONEYWELL'S WARRANTY.
- 2 - ABSOLUTE MAXIMUM RATINGS ARE THE EXTREME LIMITS THE DEVICE WILL MOMENTARILY WITHSTAND WITHOUT DAMAGE TO THE DEVICE. ELECTRICAL AND MAGNETIC CHARACTERISTICS ARE NOT GUARANTEED IF THE SPECIFIED VOLTAGE AND/OR CURRENTS ARE EXCEEDED NOR WILL THE DEVICE NECESSARILY OPERATE AT ABSOLUTE MAXIMUM RATING.
- 3 - THE MAGNETIC FLUX USED TO OPERATE THE SWITCH MUST BE IN BOTH DIRECTION AND LOCATION SHOWN. THIS IS OMNI POLAR DEVICE SENSITIVE TO EITHER POLE.
- 4 - THE MAGNETIC FIELD STRENGTH (GAUSS) REQUIRED TO CAUSE THE SWITCH TO CHANGE STATE (OPERATE AND RELEASE) WILL BE AS SPECIFIED IN THE MAGNETIC CHARACTERISTICS. TO TEST THE SWITCH AGAINST THE SPECIFIED MAGNETIC CHARACTERISTICS, THE SWITCH MUST BE PLACED IN A UNIFORM MAGNETIC FIELD.
- 5 - THIS PRODUCT WILL BE SUPPLIED IN TAPE AND REEL FORM PER EIA STD 481.
- 6 - GATE VESTAGE PERMITTED IN THESE AREAS. UNDERFLUSH BREAKOUT LIMITED TO .007.
- 7 - THESE HALL EFFECT SENSORS MAY HAVE AN INITIAL OUTPUT IN EITHER THE ON OR OFF STATE IF POWERED UP WITH AN APPLIED MAGNETIC FIELD IN THE DIFFERENTIAL ZONE (APPLIED MAGNETIC FIELD > Brp AND < Bop). HONEYWELL RECOMMENDS THAT THE APPLICATION CIRCUIT DESIGNER ALLOW 10 MICROSECONDS AFTER SUPPLY VOLTAGE HAS REACHED Vs FOR THE OUTPUT VOLTAGE TO STABILIZE.

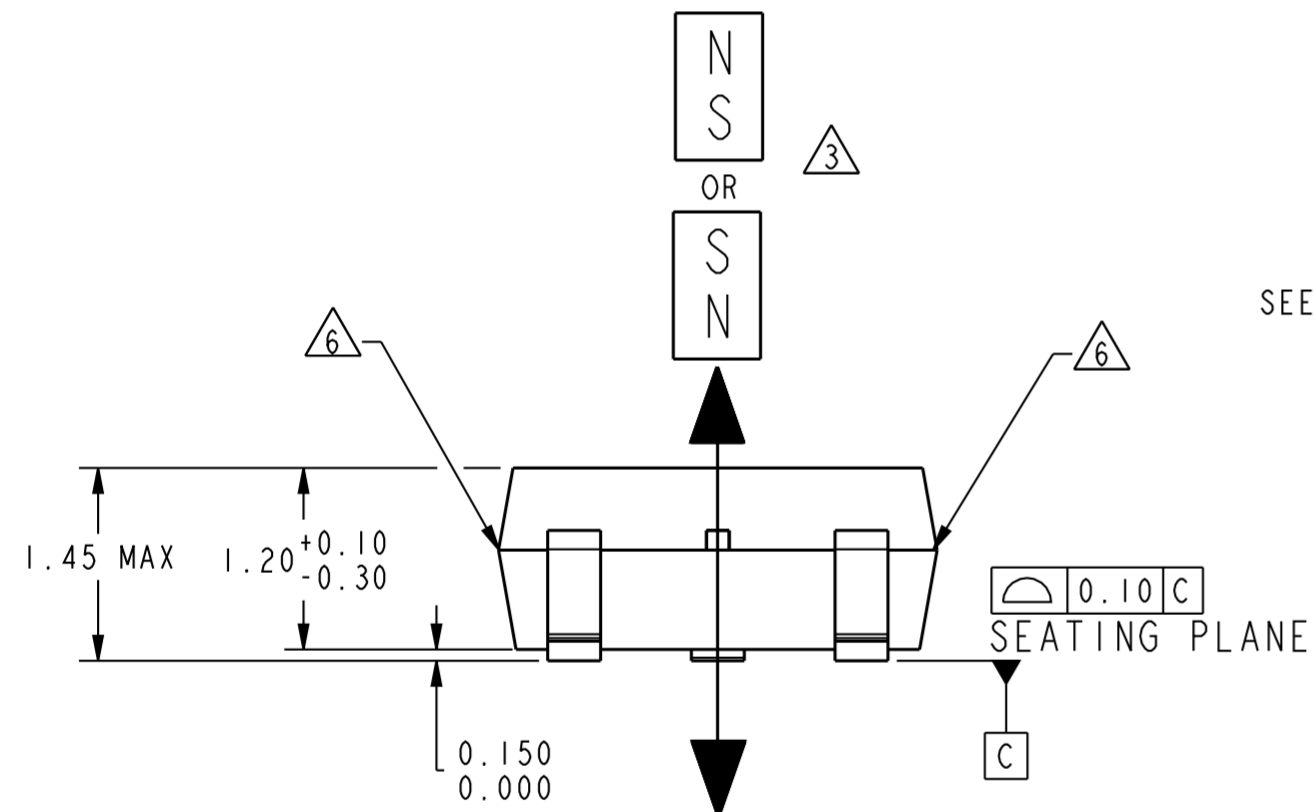

SEE DETAIL A

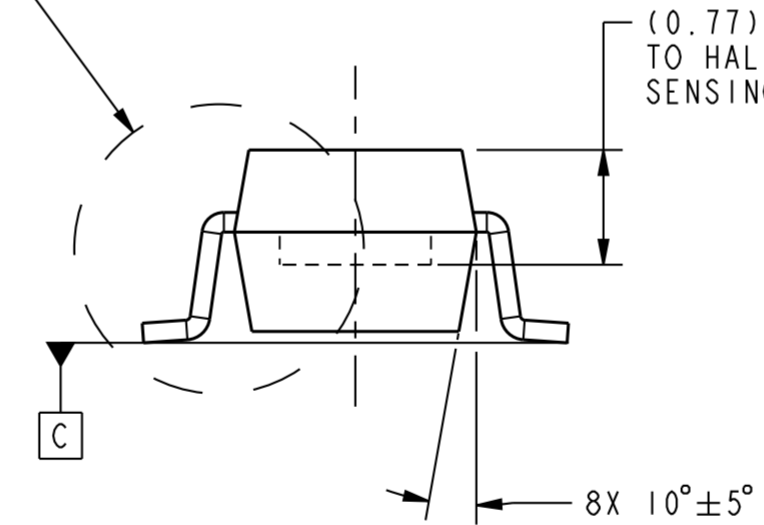

(0.77) NOMINAL TO HALL EFFECT SENSING SURFACE

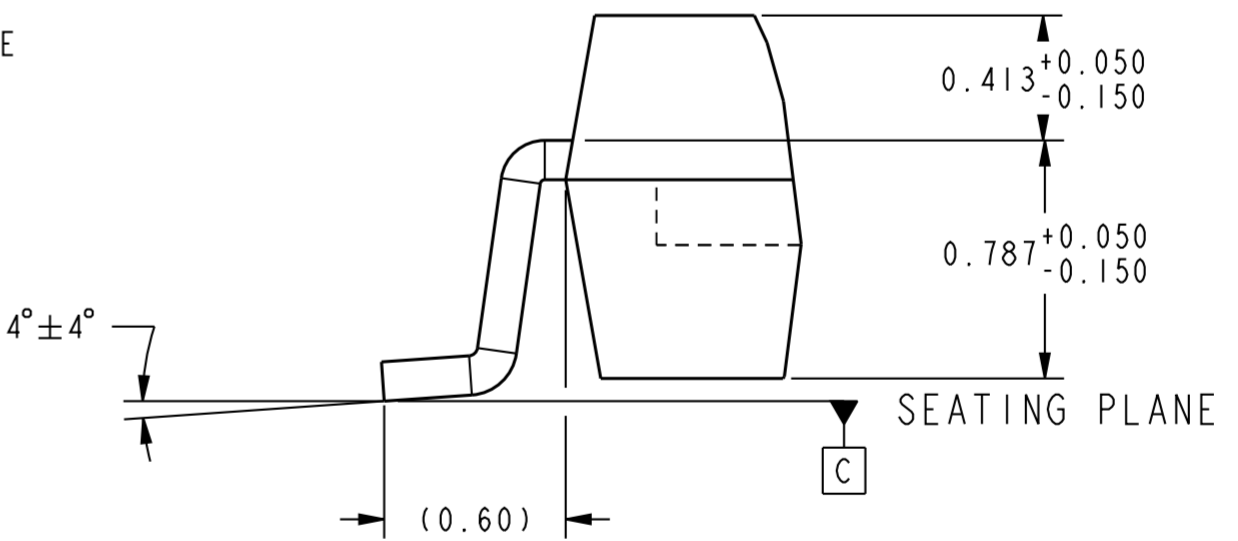

DETAIL A
SCALE 40:1

1547 LOW POWER HALL SIMPLIFIED BLOCK DIAGRAM

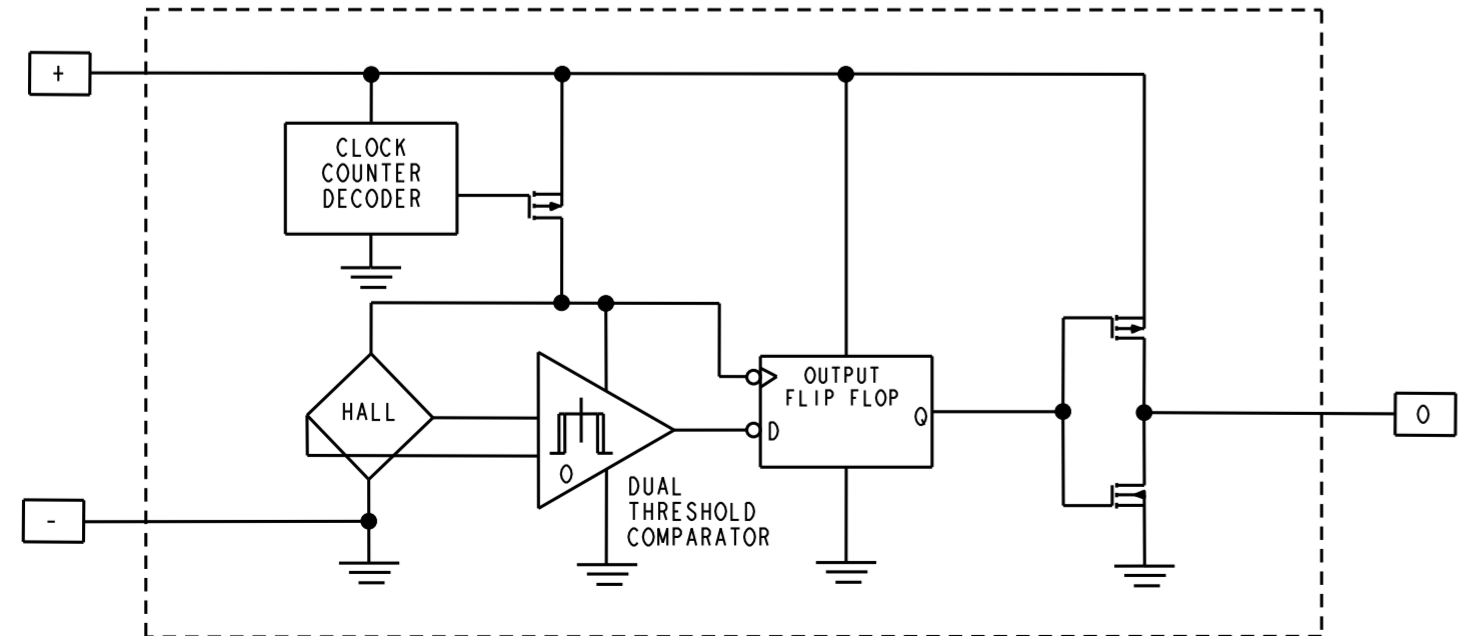

DESIGN UNITS: MM		DRAWN	JLH	23 JUN 10
TOLERANCES UNLESS NOTED:		CHECK	JLH	23 JUN 10
NO PLACES	x ±	THIS DRAWING COVERS A PROPRIETARY ITEM AND IS THE PROPERTY OF HONEYWELL. THIS DRAWING IS NOT TO BE COPIED OR USED WITHOUT THE PERMISSION OF HONEYWELL.		
ONE PLACE	.x ±	INTERPRET PER ASME Y14.5M-1994 OTHER HONEYWELL ENGINEERING STANDARDS MAY APPLY		
TWO PLACE	.xx ±	Pro/ENGINEER 3D		
THREE PLACE	.xxx ±	SCALE NONE		
ANGLES	x ±	SHEET 1 OF 4		

THIRD ANGLE PROJECTION		TITLE		REV
		LOW POWER SOLID STATE SENSOR, IC		C
		SIZE	A2	
		TYPE	I	
		PACKAGE CODE	-	
		DRAWING NAME	SL353LT	

Honeywell				
THIS DRAWING IS NOT TO BE COPIED OR USED WITHOUT THE PERMISSION OF HONEYWELL.				
INTERPRET PER ASME Y14.5M-1994 OTHER HONEYWELL ENGINEERING STANDARDS MAY APPLY				
Pro/ENGINEER 3D				
SCALE NONE				
SHEET 1 OF 4				

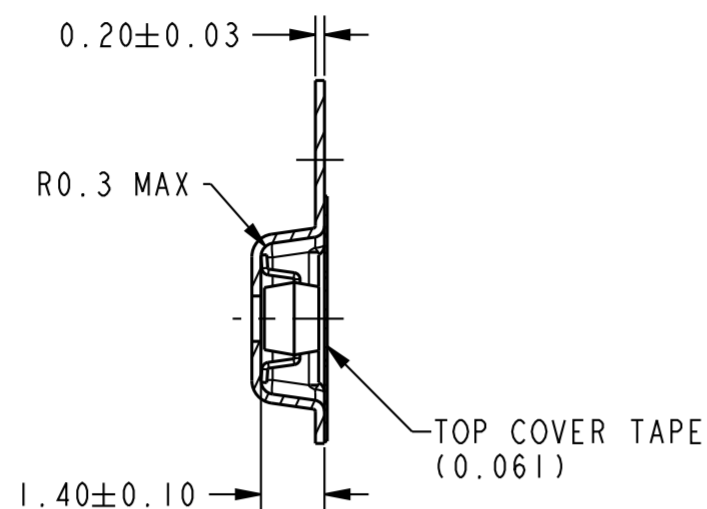

SECTION **B-B**

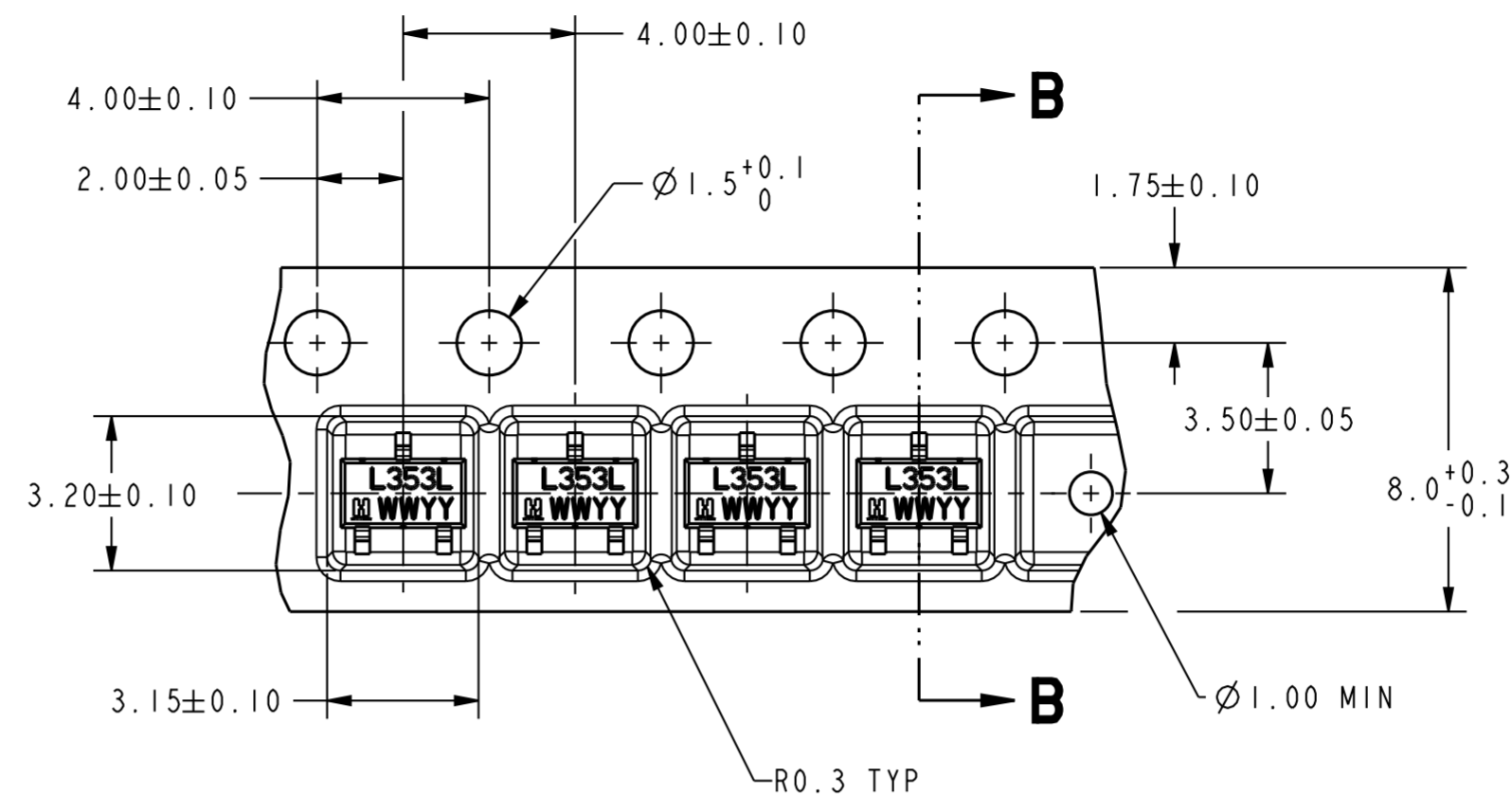

TAPE AND REEL DIMENSIONS 5

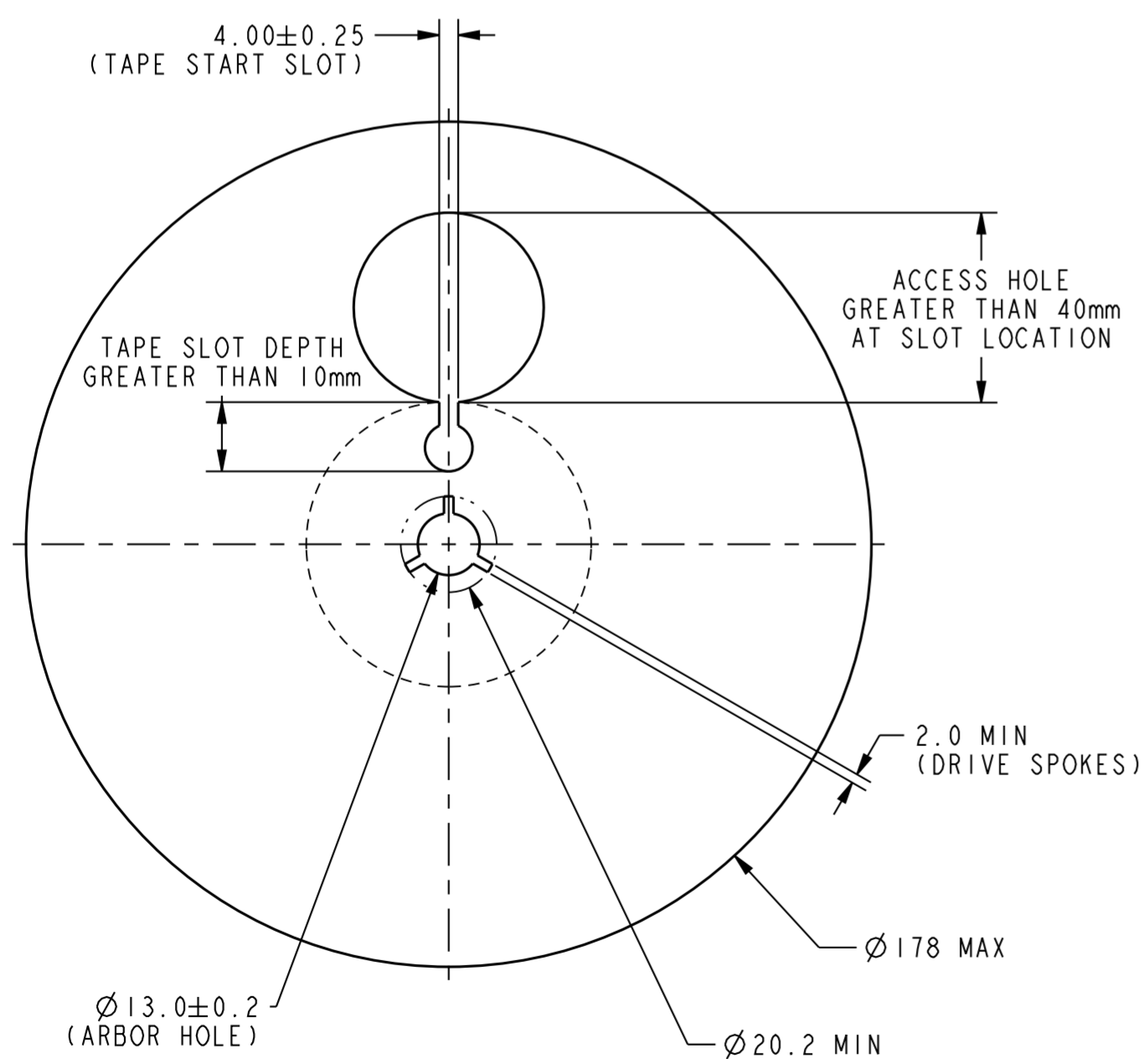

DIRECTION OF FEED FROM REEL

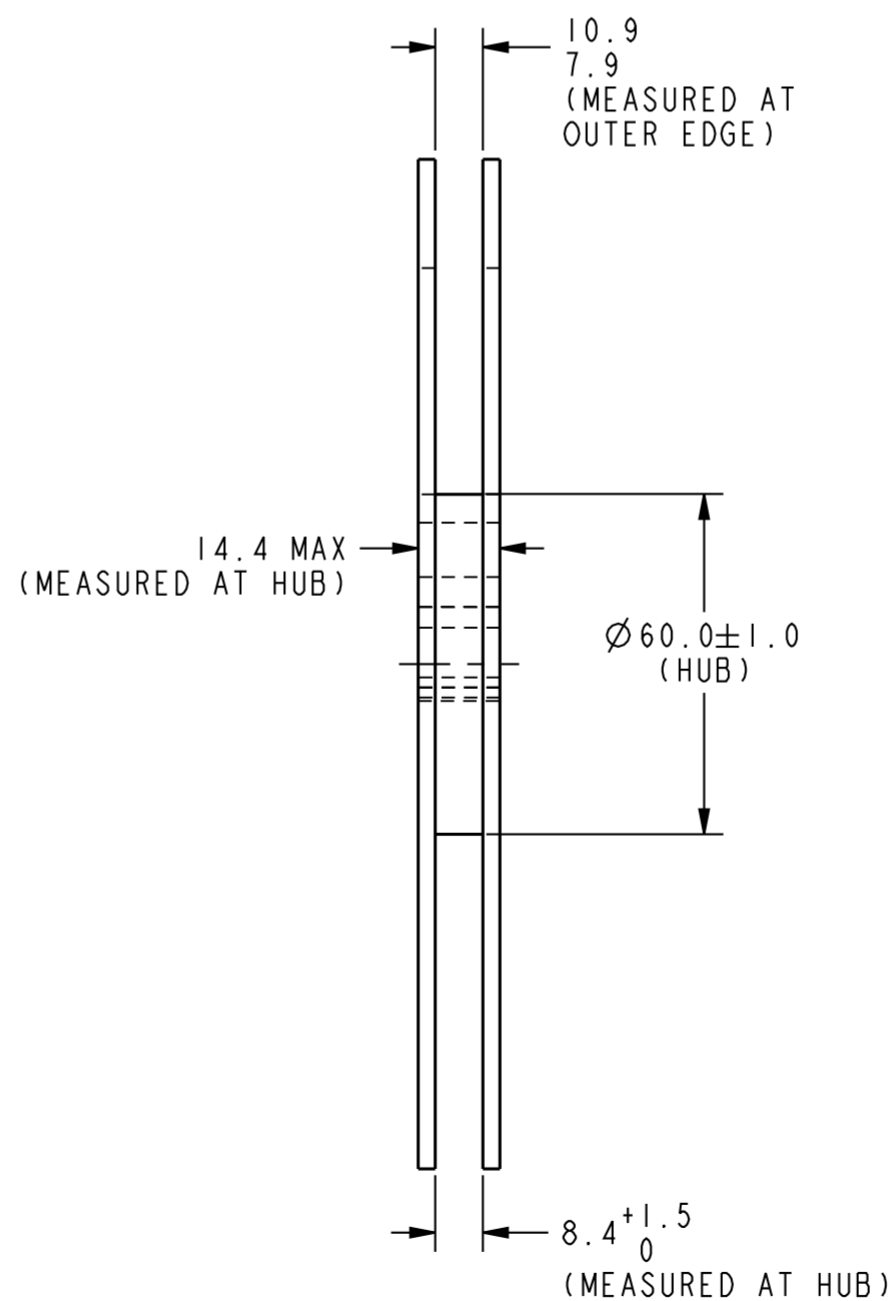

THIS DRAWING COVERS A PROPRIETARY ITEM AND IS THE PROPERTY OF HONEYWELL. THIS DRAWING IS NOT TO BE COPIED OR USED WITHOUT THE PERMISSION OF HONEYWELL.		Honeywell				
		SIZE	TYPE	CAGE CODE	DRAWING NAME	REV
		A2	I	-	SL353LT	C
		SCALE NONE		SHEET 2 OF 4		

MAGNETIC CHARACTERISTICS (2.2V ≤ V_s ≤ 5.5V, -40°C ≤ T_a ≤ 85°C)

CHARACTERISTICS	CONDITIONS	MIN	TYP	MAX	UNIT
OPERATE (POSITIVE)		20	60	110	GAUSS
OPERATE (NEGATIVE)		-110	-60	-20	GAUSS
RELEASE (POSITIVE)		5	45	95	GAUSS
RELEASE (NEGATIVE)		-95	-45	-5	GAUSS
DIFFERENTIAL		3	15	60	GAUSS

ELECTRICAL CHARACTERISTICS (2.2V ≤ V_s ≤ 5.5V, -40°C ≤ T_a ≤ 85°C UNLESS OTHERWISE SPECIFIED)

CHARACTERISTIC	CONDITIONS	MIN	TYP	MAX	UNIT
SUPPLY VOLTAGE		2.2	2.8	5.5	VOLTS
ACTIVE MODE CURRENT			2.5	9	mA
SLEEP MODE CURRENT			1.5	8	μA
AVERAGE CURRENT			1.8	9	μA
ACTIVE MODE TIME		3	6	30	μS
PERIOD		20	45	150	mS
DUTY CYCLE		0.005	0.013	0.025	%
V _{OL}	LOAD CURRENT = 100μA		0.11	0.25	VOLTS
V _{OH}	LOAD CURRENT = 100μA	V _s -0.25	V _s -0.11		VOLTS
OPERATING TEMPERATURE		-40		85	°C
STORAGE TEMPERATURE		-40		150	°C

ELECTRICAL CHARACTERISTICS (V_s = 2.8V, T_a = 25°C)

CHARACTERISTIC	CONDITIONS	MIN	TYP	MAX	UNIT
ACTIVE MODE CURRENT			2.5	4	mA
SLEEP MODE CURRENT			1.5	2.5	μA
AVERAGE CURRENT			1.8	3	μA
ACTIVE MODE TIME		3	6	9	μS
PERIOD		30	45	80	mS
DUTY CYCLE		0.01	0.013	0.016	%
V _{OL}	LOAD CURRENT = 100μA		0.11	0.15	VOLTS
V _{OH}	LOAD CURRENT = 100μA	V _s -0.15	V _s -0.11		VOLTS

ABSOLUTE MAXIMUM RATINGS

CHARACTERISTIC	CONDITIONS	MIN	TYP	MAX	UNIT
SUPPLY VOLTAGE		-0.5		6	VOLTS
OPERATING TEMPERATURE	AMBIENT	-40		150	°C
SOLDERING TEMPERATURE	APPLIED FOR < 10 SECONDS			265	°C
LOAD CURRENT				5	mA

NOTE: "ABSOLUTE MAXIMUM RATINGS" ARE THOSE VALUES BEYOND WHICH THE SAFETY OF THE DEVICE CANNOT BE GUARANTEED. THIS IS A STRESS RATING ONLY AND FUNCTIONAL OPERATION OF THE DEVICE AT THESE OR ANY OTHER CONDITIONS ABOVE THOSE INDICATED IN THE OPERATIONAL SECTIONS OF THIS SPECIFICATION IS NOT IMPLIED. EXPOSURE TO ABSOLUTE MAXIMUM RATINGS FOR EXTENDED PERIODS MAY AFFECT RELIABILITY.



THIS DRAWING COVERS A PROPRIETARY ITEM AND IS THE PROPERTY OF HONEYWELL. THIS DRAWING IS NOT TO BE COPIED OR USED WITHOUT THE PERMISSION OF HONEYWELL.

Honeywell

SIZE	TYPE	PACKAGE CODE	DRAWING NAME	REV
A2	I	-	SL353LT	C
SCALE NONE		SHEET 3 OF 4		

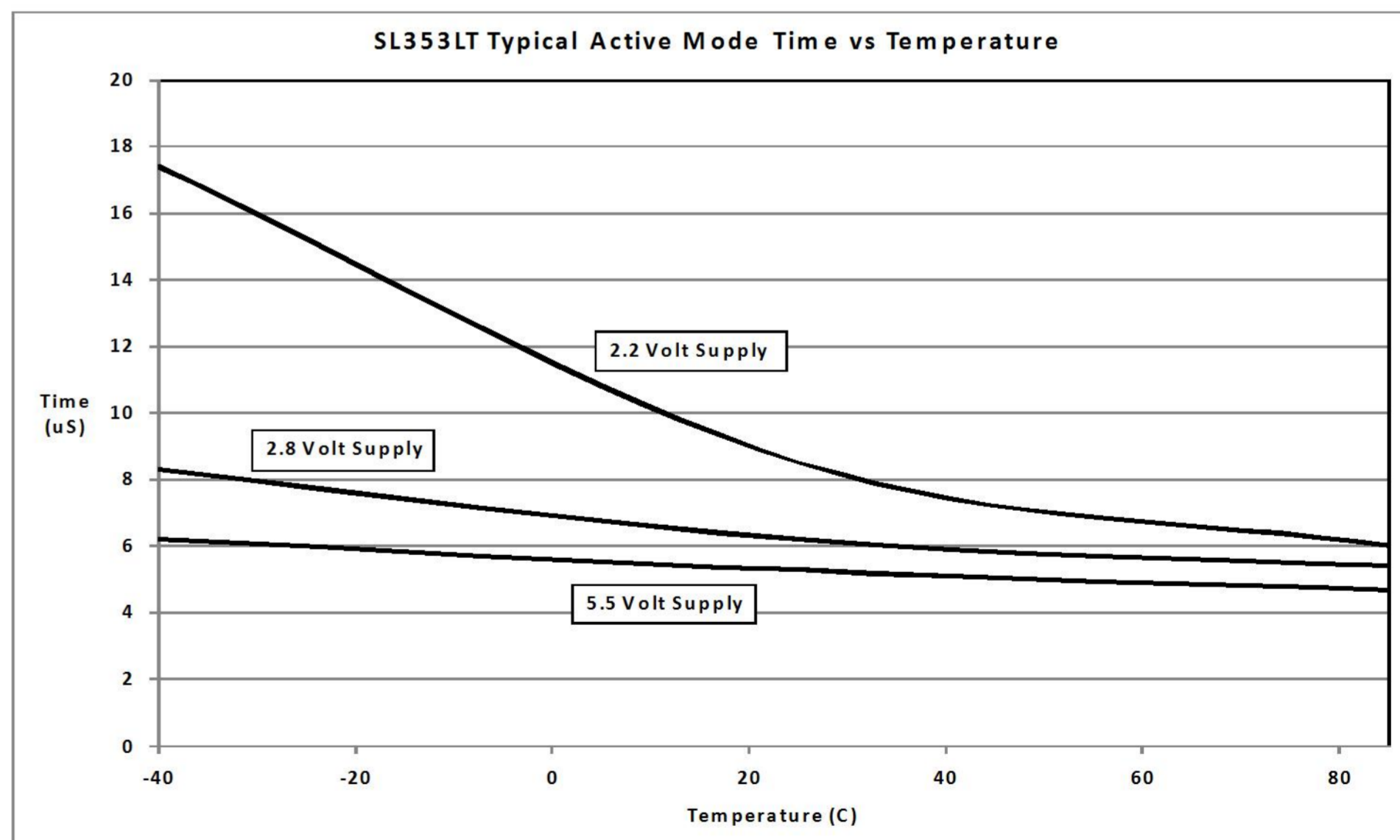
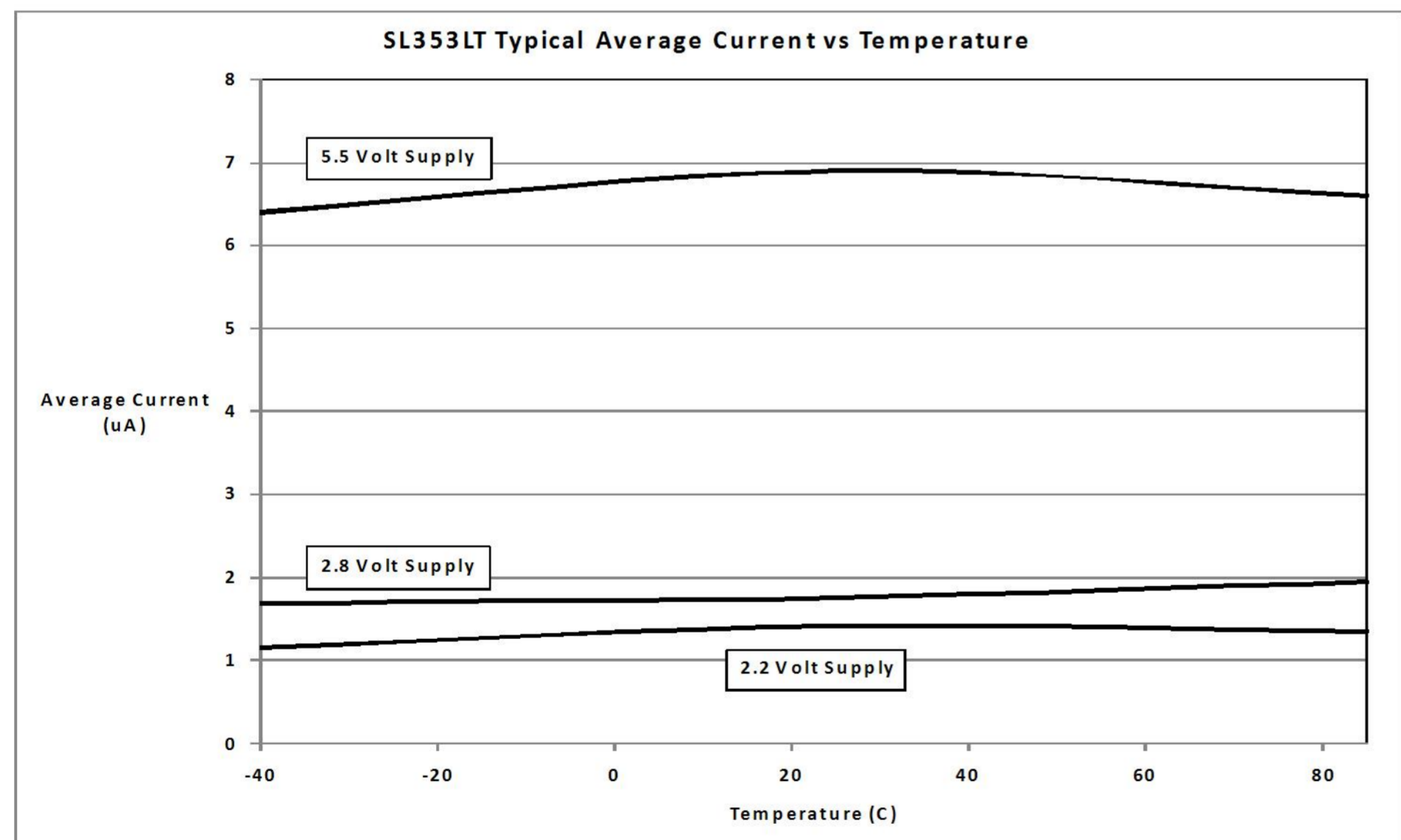
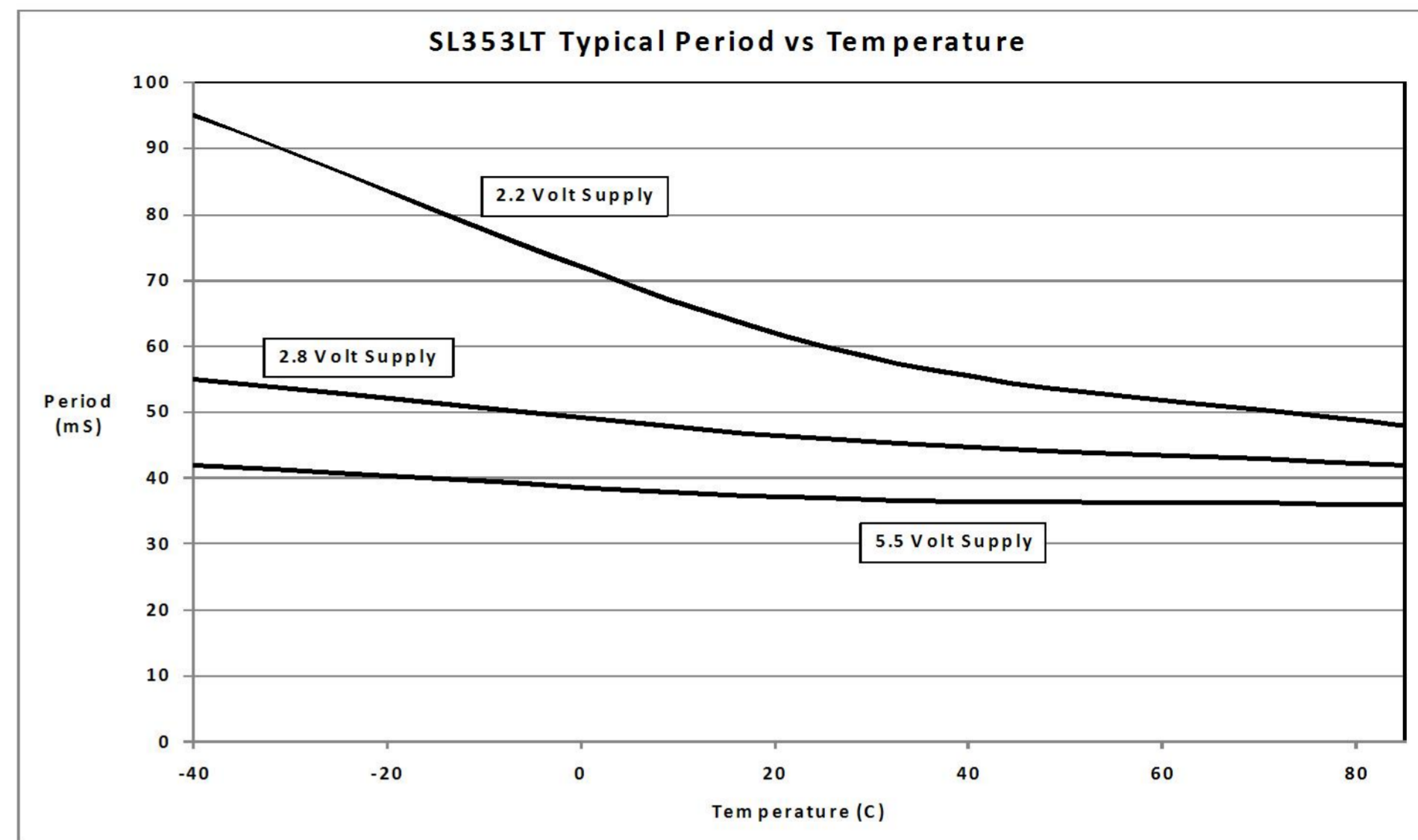
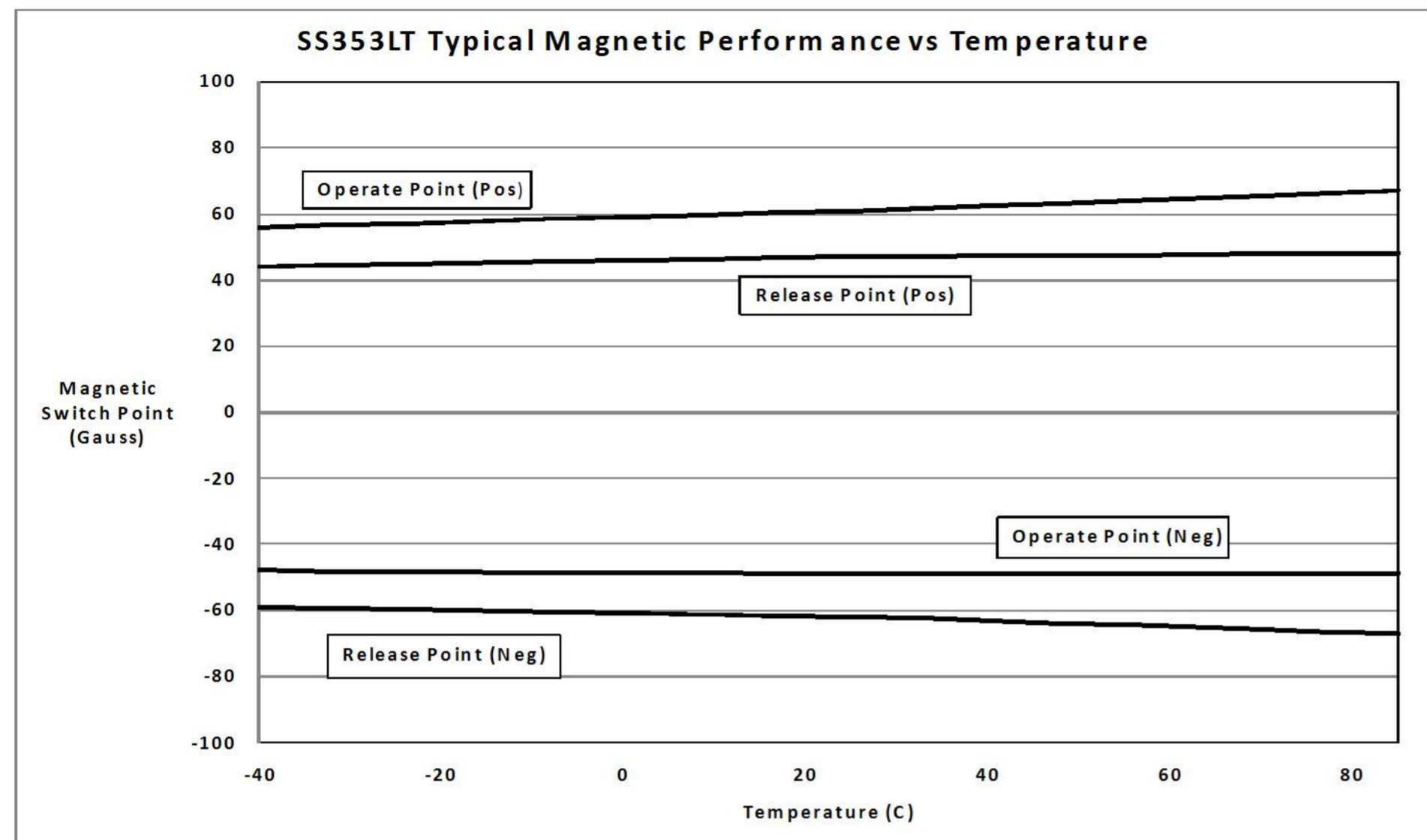

THIS DRAWING COVERS A PROPRIETARY ITEM AND IS THE PROPERTY OF HONEYWELL. THIS DRAWING IS NOT TO BE COPIED OR USED WITHOUT THE PERMISSION OF HONEYWELL.

Honeywell			
SIZE	TYPE	CAGE CODE	DRAWING NAME
A2	I	-	SL353LT
SCALE	NONE	SHEET	4 OF 4
REV	C		

Данный компонент на территории Российской Федерации

Вы можете приобрести в компании MosChip.

Для оперативного оформления запроса Вам необходимо перейти по данной ссылке:

<http://moschip.ru/get-element>

Вы можете разместить у нас заказ для любого Вашего проекта, будь то серийное производство или разработка единичного прибора.

В нашем ассортименте представлены ведущие мировые производители активных и пассивных электронных компонентов.

Нашей специализацией является поставка электронной компонентной базы двойного назначения, продукции таких производителей как XILINX, Intel (ex.ALTERA), Vicor, Microchip, Texas Instruments, Analog Devices, Mini-Circuits, Amphenol, Glenair.

Сотрудничество с глобальными дистрибьюторами электронных компонентов, предоставляет возможность заказывать и получать с международных складов практически любой перечень компонентов в оптимальные для Вас сроки.

На всех этапах разработки и производства наши партнеры могут получить квалифицированную поддержку опытных инженеров.

Система менеджмента качества компании отвечает требованиям в соответствии с ГОСТ Р ИСО 9001, ГОСТ РВ 0015-002 и ЭС РД 009

Офис по работе с юридическими лицами:

105318, г.Москва, ул.Щербаковская д.3, офис 1107, 1118, ДЦ «Щербаковский»

Телефон: +7 495 668-12-70 (многоканальный)

Факс: +7 495 668-12-70 (доб.304)

E-mail: info@moschip.ru

Skype отдела продаж:

moschip.ru

moschip.ru_4

moschip.ru_6

moschip.ru_9