

Features

- Supply Voltage 4.5V to 5.5V
- Operating Temperature Range -40°C to $+85^{\circ}\text{C}$
- Minimal External Circuitry Requirements, No RF Components on the PC Board Except Matching to the Receiver Antenna
- High Sensitivity, Especially at Low Data Rates
- Sensitivity Reduction Possible Even While Receiving
- Fully Integrated VCO
- Low Power Consumption Due to Configurable Self-polling with a Programmable Time Frame Check
- Single-ended RF Input for Easy Matching to $\lambda / 4$ Antenna or Printed Antenna on PCB
- Low-cost Solution Due to High Integration Level
- ESD Protection According to MIL-STD 883 (4 KV HBM) Except Pin POUT (2 KV HBM)
- High Image Frequency Suppression Due to 1 MHz IF in Conjunction With a SAW Front-end Filter. Up to 40 dB is Thereby Achievable With Newer SAWs
- Programmable Output Port for Sensitivity Selection or for Controlling External Periphery
- Communication to the Microcontroller Possible via a Single, Bi-directional Data Line
- Power Management (Polling) is also Possible by Means of a Separate Pin via the Microcontroller

1. Description

The ATA3745 is a multi-chip PLL receiver device supplied in an SO20 package. It has been specially developed for the demands of RF low-cost data transmission systems with low data rates from 1 kBaud to 10 kBaud in Manchester or Bi-phase code. The receiver is well-suited to operate with Atmel's PLL RF transmitter ATA2745. It can be used in the frequency receiving range of $f_0 = 310\text{ MHz}$ to 440 MHz for ASK data transmission. All the statements made below refer to 433.92 MHz and 315 MHz applications.

The main applications of the ATA3745 are in the areas of outside temperature metering, socket control, garage door openers, consumption metering, light/fan or air-conditioning control, jalousies, wireless keyboards, and various other consumer market applications.



UHF ASK/FSK Receiver

ATA3745

Figure 1-1. System Block Diagram

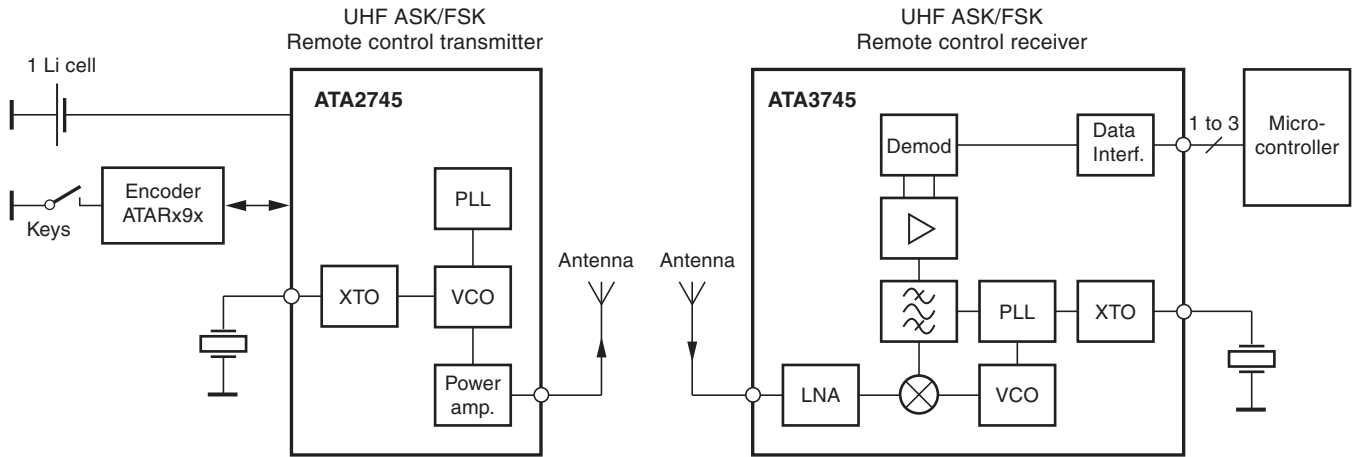
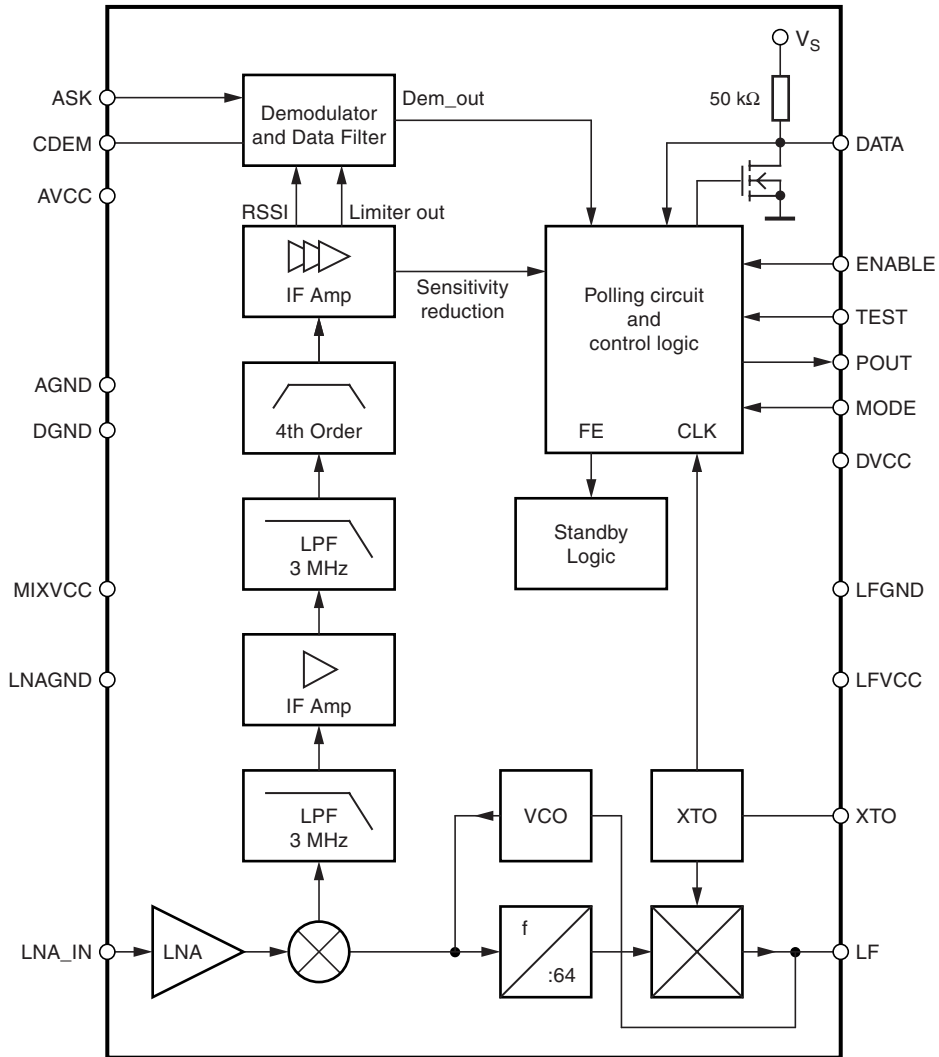

Figure 1-2. Block Diagram



2. Pin Configuration

Figure 2-1. Pinning SO20

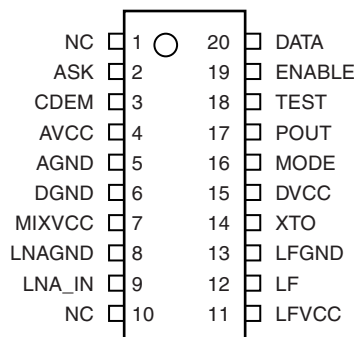

Table 2-1. Pin Description

Pin	Symbol	Function
1	NC	Not connected
2	ASK	ASK high
3	CDEM	Lower cut-off frequency data filter
4	AVCC	Analog power supply
5	AGND	Analog ground
6	DGND	Digital ground
7	MIXVCC	Power supply mixer
8	LNAGND	High-frequency ground LNA and mixer
9	LNA_IN	RF input
10	NC	Not connected
11	LFVCC	Power supply VCO
12	LF	Loop filter
13	LFGND	Ground VCO
14	XTO	Crystal oscillator
15	DVCC	Digital power supply
16	MODE	Selecting 433.92 MHz/315 MHz. Low: 4.90625 MHz (USA), High: 6.76438 MHz (Europe)
17	POUT	Programmable output port
18	TEST	Test pin, during operation at GND
19	ENABLE	Enables the polling mode. Low: polling mode off (sleep mode). High: polling mode on (active mode)
20	DATA	Data output/configuration input

3. RF Front End

The RF front end of the receiver is a heterodyne configuration that converts the input signal into a 1-MHz IF signal. As shown in the block diagram, the front end consists of an LNA (low noise amplifier), LO (local oscillator), a mixer and an RF amplifier.

The LO generates the carrier frequency for the mixer via a PLL synthesizer. The XTO (crystal oscillator) generates the reference frequency f_{XTO} . The VCO (voltage-controlled oscillator) generates the drive voltage frequency f_{LO} for the mixer. f_{LO} is dependent on the voltage at pin LF. f_{LO} is divided by a factor of 64. The divided frequency is compared to f_{XTO} by the phase frequency detector. The current output of the phase frequency detector is connected to a passive loop filter and thereby generates the control voltage V_{LF} for the VCO. By means of that configuration, V_{LF} is controlled such that $f_{LO} / 64$ is equal to f_{XTO} . If f_{LO} is determined, f_{XTO} can be calculated using the following formula:

$$f_{XTO} = \frac{f_{LO}}{64}$$

The XTO is a one-pin oscillator that operates at the series resonance of the quartz crystal. [Figure 3-1](#) shows the proper layout, with the crystal connected to GND via a capacitor C_L . The value of that capacitor is recommended by the crystal supplier. The value of C_L should be optimized for the individual board layout to achieve the exact value of f_{XTO} and thereby of f_{LO} . When designing the system in terms of receiving bandwidth, the accuracy of the crystal and XTO must be considered.

Figure 3-1. PLL Peripherals

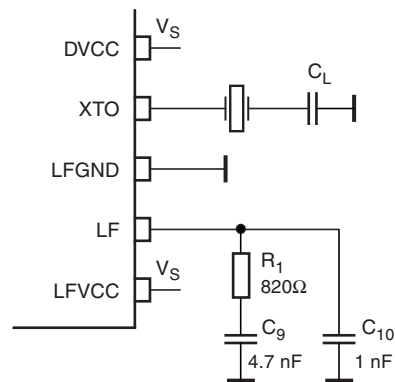

The passive loop filter connected to pin LF is designed for a loop bandwidth of $B_{Loop} = 100$ kHz. This value for B_{Loop} exhibits the best possible noise performance of the LO. [Figure 3-1](#) shows the appropriate loop filter components to achieve the desired loop bandwidth. If the filter components are changed for any reason, please note that the maximum capacitive load at pin LF is limited. If the capacitive load is exceeded, a bit check may no longer be possible since f_{LO} cannot settle in time before the bit check starts to evaluate the incoming data stream. Therefore, self polling also does not work in that case.

f_{LO} is determined by the RF input frequency f_{RF} and the IF frequency f_{IF} using the following formula: $f_{LO} = f_{RF} - f_{IF}$

To determine f_{LO} , the construction of the IF filter must be considered at this point. The nominal IF frequency is $f_{IF} = 1$ MHz. To achieve a good accuracy of the filter's corner frequencies, the filter is tuned by the crystal frequency f_{XTO} . This means that there is a fixed relation between f_{IF} and f_{LO} that depends on the logic level at pin MODE. This is described by the following formulas:

$$\text{MODE} = 0 \text{ (USA)} \quad f_{IF} = \frac{f_{LO}}{314}$$

$$\text{MODE} = 1 \text{ (Europe)} \quad f_{IF} = \frac{f_{LO}}{432.92}$$

The relation is designed to achieve the nominal IF frequency of $f_{IF} = 1$ MHz for most applications. For applications where $f_{RF} = 315$ MHz, the MODE must be set to "0". In the case of $f_{RF} = 433.92$ MHz, the MODE must be set to "1". For other RF frequencies, f_{IF} is not equal to 1 MHz. f_{IF} is then dependent on the logical level at pin MODE and on f_{RF} . [Table 3-1](#) summarizes the different conditions.

The RF input either from an antenna or from a generator must be transformed to the RF input pin LNA_IN. The input impedance of that pin is provided in the electrical parameters. The parasitic board inductances and capacitances also influence the input matching. The RF receiver ATA3745 exhibits its highest sensitivity at the best signal-to-noise ratio (SNR) in the LNA. Hence, noise matching is the best choice for designing the transformation network.

A good practice when designing the network is to start with power matching. From that starting point, the values of the components can be varied to some extent to achieve the best sensitivity.

If a SAW is implemented into the input network, a mirror frequency suppression of $\Delta P_{Ref} = 40$ dB can be achieved. There are SAWs available that exhibit a notch at $\Delta f = 2$ MHz. These SAWs work best for an intermediate frequency of IF = 1 MHz. The selectivity of the receiver is also improved by using a SAW. In typical automotive applications, a SAW is used.

[Figure 3-2 on page 6](#) shows a typical input matching network for $f_{RF} = 315$ MHz and $f_{RF} = 433.92$ MHz using a SAW. [Figure 3-3 on page 6](#) illustrates an input matching to 50Ω without a SAW. The input matching networks shown in [Figure 3-3 on page 6](#) are the reference networks for the parameters given in the section "[Electrical Characteristics](#)" on [page 23](#).

Table 3-1. Calculation of LO and IF Frequency

Conditions	Local Oscillator Frequency	Intermediate Frequency
$f_{RF} = 315$ MHz, MODE = 0	$f_{LO} = 314$ MHz	$f_{IF} = 1$ MHz
$f_{RF} = 433.92$ MHz, MODE = 1	$f_{LO} = 432.92$ MHz	$f_{IF} = 1$ MHz
$300 \text{ MHz} < f_{RF} < 365 \text{ MHz}$, MODE = 0	$f_{LO} = \frac{f_{RF}}{1 + \frac{1}{314}}$	$f_{IF} = \frac{f_{LO}}{314}$
$365 \text{ MHz} < f_{RF} < 450 \text{ MHz}$, MODE = 1	$f_{LO} = \frac{f_{RF}}{1 + \frac{1}{432.92}}$	$f_{IF} = \frac{f_{LO}}{432.92}$

Figure 3-2. Input Matching Network With SAW Filter

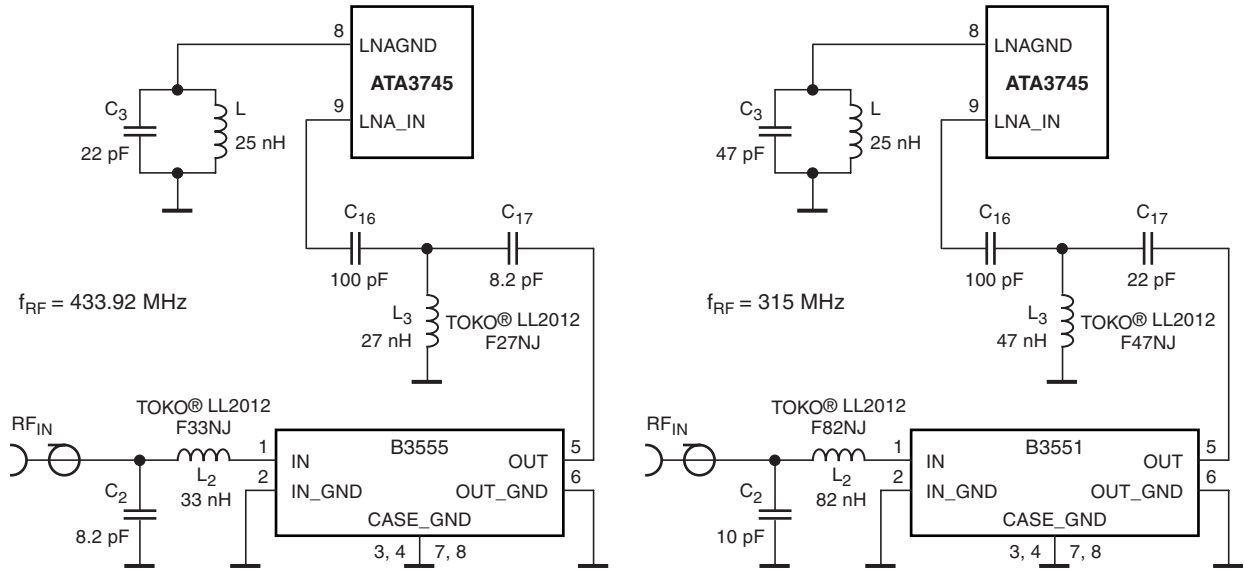
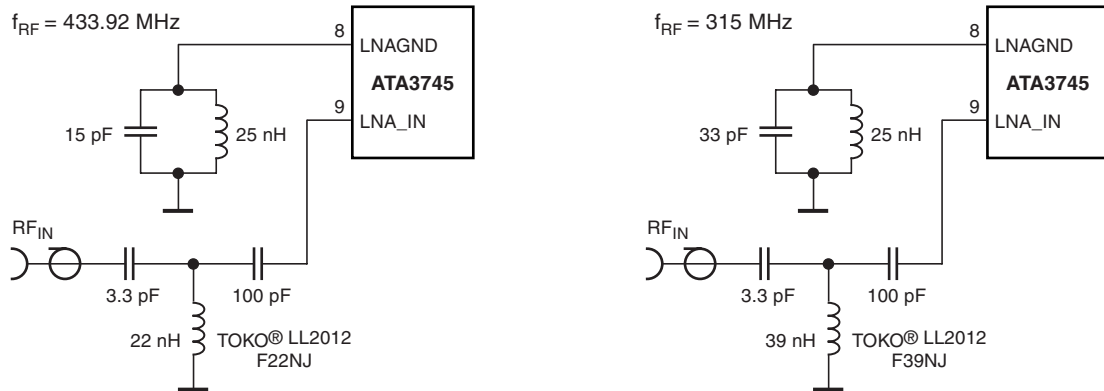

Figure 3-3. Input Matching Network Without SAW Filter



Please note that for all coupling conditions (see [Figure 3-2](#) and [Figure 3-3](#)), the bond wire inductivity of the LNA ground is compensated. C₃ forms a series resonance circuit together with the bond wire. L = 25 nH is a feed inductor to establish a DC path. Its value is not critical but must be large enough not to detune the series resonance circuit. For cost reduction, this inductor can be easily printed on the PCB. This configuration improves the sensitivity of the receiver by about 1 dB to 2 dB.

4. Analog Signal Processing

4.1 IF Amplifier

The signals coming from the RF front end are filtered by the fully integrated 4th-order IF filter. The IF center frequency is $f_{IF} = 1$ MHz for applications where $f_{RF} = 315$ MHz or $f_{RF} = 433.92$ MHz is used. For other RF input frequencies, refer to [Table 3-1 on page 5](#) to determine the center frequency.

The receiver ATA3745 employs an IF bandwidth of $B_{IF} = 600$ kHz. This IC can be used together with the ATA2745. SAW transmitters exhibit much higher transmit frequency tolerances compared to PLL transmitters. Generally, it is necessary to use $B_{IF} = 600$ kHz together with such transmitters.

4.2 RSSI Amplifier

The subsequent RSSI amplifier enhances the output signal of the IF amplifier before it is fed into the demodulator. The dynamic range of this amplifier is $\Delta R_{RSSI} = 60$ dB. If the RSSI amplifier is operated within its linear range, the best signal-to-noise ratio (SNR) is maintained in ASK mode. If the dynamic range is exceeded by the transmitter signal, the SNR is defined by the ratio of the maximum RSSI output voltage and the RSSI output voltage due to a disturber. The dynamic range of the RSSI amplifier is exceeded if the RF input signal is about 60 dB higher compared to the RF input signal at full sensitivity.

Since different RF input networks may exhibit slightly different values for the LNA gain, the sensitivity values given in the electrical characteristics refer to a specific input matching. This matching is illustrated in [Figure 3-3 on page 6](#) and exhibits the best possible sensitivity.

4.3 Demodulator and Data Filter

The signal coming from the RSSI amplifier is converted into the raw data signal by the ASK demodulator.

In ASK mode, an automatic threshold control (ATC) circuit is employed to set the detection reference voltage to a value where a good SNR is achieved. This circuit also implies the effective suppression of any kind of in-band noise signals or competing transmitters. If the SNR exceeds 10 dB, the data signal can be detected properly.

The output signal of the demodulator is filtered by the data filter before it is fed into the digital signal processing circuit. The data filter improves the SNR as its band-pass can be adapted to the characteristics of the data signal. The data filter consists of a 1st-order high-pass and a 1st-order low-pass filter.

The high-pass filter cut-off frequency is defined by an external capacitor connected to pin CDEM. The cut-off frequency of the high-pass filter is defined by the following formula:

$$f_{cu_DF} = \frac{1}{2 \times \pi \times 30 \text{ k}\Omega \times CDEM}$$

In self-polling mode, the data filter must settle very rapidly to achieve a low current consumption. Therefore, CDEM cannot be increased to very high values if self polling is used. On the other hand, CDEM must be large enough to meet the data filter requirements according to the data signal. Recommended values for CDEM are given in the section [“Electrical Characteristics” on page 23](#).

The cut-off frequency of the low-pass filter is defined by the selected baud rate range (BR_Range). BR_Range is defined in the OPMODE register (refer to “[Configuration of the Receiver](#)” on page 18). BR_Range must be set in accordance to the used baud rate.

The ATA3745 is designed to operate with data encoding where the DC level of the data signal is 50%. This is valid for Manchester and Bi-phase encoding. If other modulation schemes are used, the DC level should always remain within the range of $V_{DC_min} = 33\%$ and $V_{DC_max} = 66\%$. The sensitivity may be reduced by up to 1.5 dB in that condition.

Each BR_Range is also defined by a minimum and a maximum edge-to-edge time (t_{ee_sig}). These limits are defined in the section “[Electrical Characteristics](#)” on page 23. They should not be exceeded to maintain full sensitivity of the receiver.

4.4 Receiving Characteristics

The RF receiver ATA3745 can be operated with and without a SAW front end filter. The selectivity with and without a SAW front-end filter is illustrated in [Figure 4-1](#). This example relates to ASK mode of the ATA3745. Note that the mirror frequency is reduced by 40 dB. The plots are printed relative to the maximum sensitivity. If a SAW filter is used, an insertion loss of about 4 dB must be considered.

When designing the system in terms of receiving bandwidth, the LO deviation must be considered as it also determines the IF center frequency. The total LO deviation is calculated to be the sum of the deviation of the crystal and the XTO deviation of the ATA3745. Low-cost crystals are specified to be within ± 100 ppm. The XTO deviation of the ATA3745 is an additional deviation due to the XTO circuit. This deviation is specified to be ± 50 ppm. If a crystal of ± 100 ppm is used, the total deviation is ± 150 ppm in that case. Note that the receiving bandwidth and the IF-filter bandwidth are equivalent in ASK mode.

Figure 4-1. Receiving Frequency Response

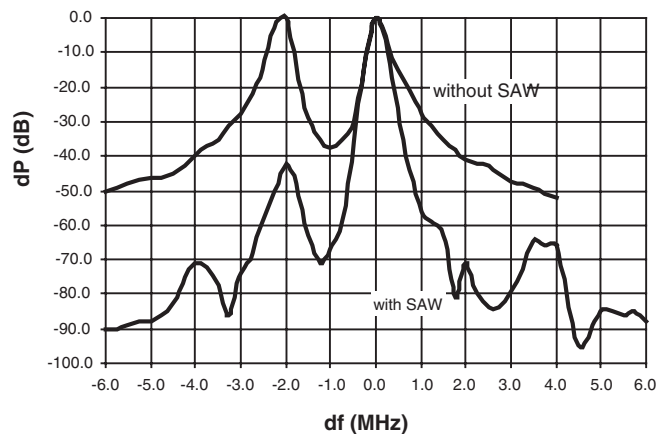

5. Polling Circuit and Control Logic

The receiver is designed to consume less than 1 mA while being sensitive to signals from a corresponding transmitter. This is achieved via the polling circuit. This circuit enables the signal path periodically for a short time. During this time, the bit check logic verifies the presence of a valid transmitter signal. Only if a valid signal is detected does the receiver remain active and transfer the data to the connected microcontroller. If there is no valid signal present, the receiver is in sleep mode most of the time, resulting in low current consumption. This condition is called polling mode. A connected microcontroller is disabled during that time.

All relevant parameters of the polling logic can be configured by the connected microcontroller. This flexibility enables the user to meet the specifications in terms of current consumption, system response time, data rate, etc.

Regarding the number of connection wires to the microcontroller, the receiver is very flexible. It can be either operated by a single bi-directional line to save ports to the connected microcontroller, or it can be operated by up to three uni-directional ports.

5.1 Basic Clock Cycle of the Digital Circuitry

The complete timing of the digital circuitry and the analog filtering is derived from one clock. Figure 5-1 shows how this clock cycle T_{CLK} is derived from the crystal oscillator (XTO) in combination with a divider. The division factor is controlled by the logical state at pin MODE. As described in “RF Front End” on page 4, the frequency of the crystal oscillator (f_{XTO}) is defined by the RF input signal (f_{RFIn}) which also defines the operating frequency of the local oscillator (f_{LO}).

Figure 5-1. Generation of the Basic Clock Cycle

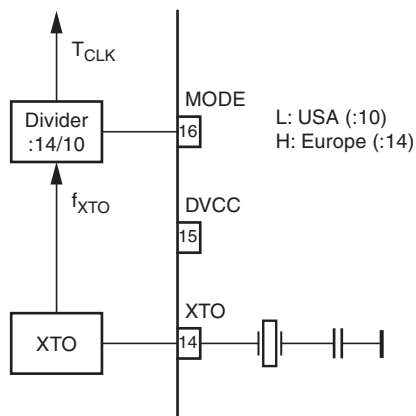

Pin MODE can now be set in accordance with the desired clock cycle T_{CLK} . T_{CLK} controls the following application-relevant parameters:

- Timing of the polling circuit including bit check
- Timing of analog and digital signal processing
- Timing of register programming
- Frequency of the reset marker
- IF filter center frequency (f_{IF0})

Most applications are dominated by two transmission frequencies: $f_{\text{Send}} = 315 \text{ MHz}$ is mainly used in the USA, $f_{\text{Send}} = 433.92 \text{ MHz}$ in Europe. In order to ease the usage of all T_{Clk} -dependent parameters, the electrical characteristics display three conditions for each parameter.

- USA applications
($f_{\text{XTO}} = 4.90625 \text{ MHz}$, $\text{MODE} = \text{L}$, $T_{\text{Clk}} = 2.0383 \mu\text{s}$)
- European applications
($f_{\text{XTO}} = 6.76438 \text{ MHz}$, $\text{MODE} = \text{H}$, $T_{\text{Clk}} = 2.0697 \mu\text{s}$)
- Other applications
(T_{Clk} is dependent on f_{XTO} and on the logical state of pin MODE . The electrical characteristic is given as a function of T_{Clk}).

The clock cycle of some function blocks depends on the selected baud rate range (BR_Range) which is defined in the OPMODE register. This clock cycle T_{XClk} is defined by the following formulas for further reference:

$\text{BR_Range} =$	BR_Range0:	$T_{\text{XClk}} = 8 \times T_{\text{Clk}}$
	BR_Range1:	$T_{\text{XClk}} = 4 \times T_{\text{Clk}}$
	BR_Range2:	$T_{\text{XClk}} = 2 \times T_{\text{Clk}}$
	BR_Range3:	$T_{\text{XClk}} = 1 \times T_{\text{Clk}}$

5.2 Polling Mode

According to [Figure 3-2 on page 6](#), the receiver stays in polling mode in a continuous cycle of three different modes. In sleep mode, the signal processing circuitry is disabled for the time period T_{Sleep} while consuming low current of $I_{\text{S}} = I_{\text{Soff}}$. During the start-up period, T_{Startup} , all signal processing circuits are enabled and settled. In the following bit check mode, the incoming data stream is analyzed bit by bit looking for a valid transmitter signal. If no valid signal is present, the receiver is set back to sleep mode after the period T_{Bitcheck} . This period varies check by check as it is a statistical process. An average value for T_{Bitcheck} is given in the section [“Electrical Characteristics” on page 23](#). During T_{Startup} and T_{Bitcheck} the current consumption is $I_{\text{S}} = I_{\text{Son}}$. The average current consumption in polling mode is dependent on the duty cycle of the active mode and can be calculated as:

$$I_{\text{Spoll}} = \frac{I_{\text{Soff}} \times T_{\text{Sleep}} + I_{\text{Son}} \times (T_{\text{Startup}} + T_{\text{Bitcheck}})}{T_{\text{Sleep}} + T_{\text{Startup}} + T_{\text{Bitcheck}}}$$

During T_{Sleep} and T_{Startup} , the receiver is not sensitive to a transmitter signal. To guarantee the reception of a transmitted command, the transmitter must start the telegram with an adequate preburst. The required length of the preburst is dependent on the polling parameters T_{Sleep} , T_{Startup} , T_{Bitcheck} and the startup time of a connected microcontroller ($T_{\text{Start}_{\mu\text{C}}}$). T_{Bitcheck} thus depends on the actual bit rate and the number of bits (N_{Bitcheck}) to be tested.

The following formula indicates how to calculate the preburst length.

$$T_{\text{Purburst}} \geq T_{\text{Sleep}} + T_{\text{Startup}} + T_{\text{Bitcheck}} + T_{\text{Start}_{\mu\text{C}}}$$

5.2.1 Sleep Mode

The length of period T_{Sleep} is defined by the 5-bit word Sleep of the OPMODE register, the extension factor X_{Sleep} described in [Table 5-8 on page 20](#), and the basic clock cycle T_{Clk} . It is calculated to be:

$$T_{\text{Sleep}} = \text{Sleep} \times X_{\text{Sleep}} \times 1024 \times T_{\text{Clk}}$$

In US and European applications, the maximum value of T_{Sleep} is about 60 ms if X_{Sleep} is set to 1. The time resolution is about 2 ms in that case. The sleep time can be extended to almost half a second by setting X_{Sleep} to 8. X_{Sleep} can be set to 8 by bit X_{SleepStd} or by bit $X_{\text{SleepTemp}}$, resulting in a different mode of action as described below:

$X_{\text{SleepStd}} = 1$ implies the standard extension factor. The sleep time is always extended.

$X_{\text{SleepTemp}} = 1$ implies the temporary extension factor. The extended sleep time is used as long as every bit check is OK. If the bit check fails once, this bit is set back to 0 automatically, resulting in a regular sleep time. This functionality can be used to save current in presence of a modulated disturber similar to an expected transmitter signal. The connected microcontroller is rarely activated in that condition. If the disturber disappears, the receiver switches back to regular polling and is again sensitive to appropriate transmitter signals.

[Table 5-6 on page 19](#) shows how the highest register value of Sleep sets the receiver to a permanent sleep condition. The receiver remains in that condition until another value for Sleep is programmed into the OPMODE register. This function is desirable where several devices share a single data line.

Figure 5-2. Polling Mode Flow Chart

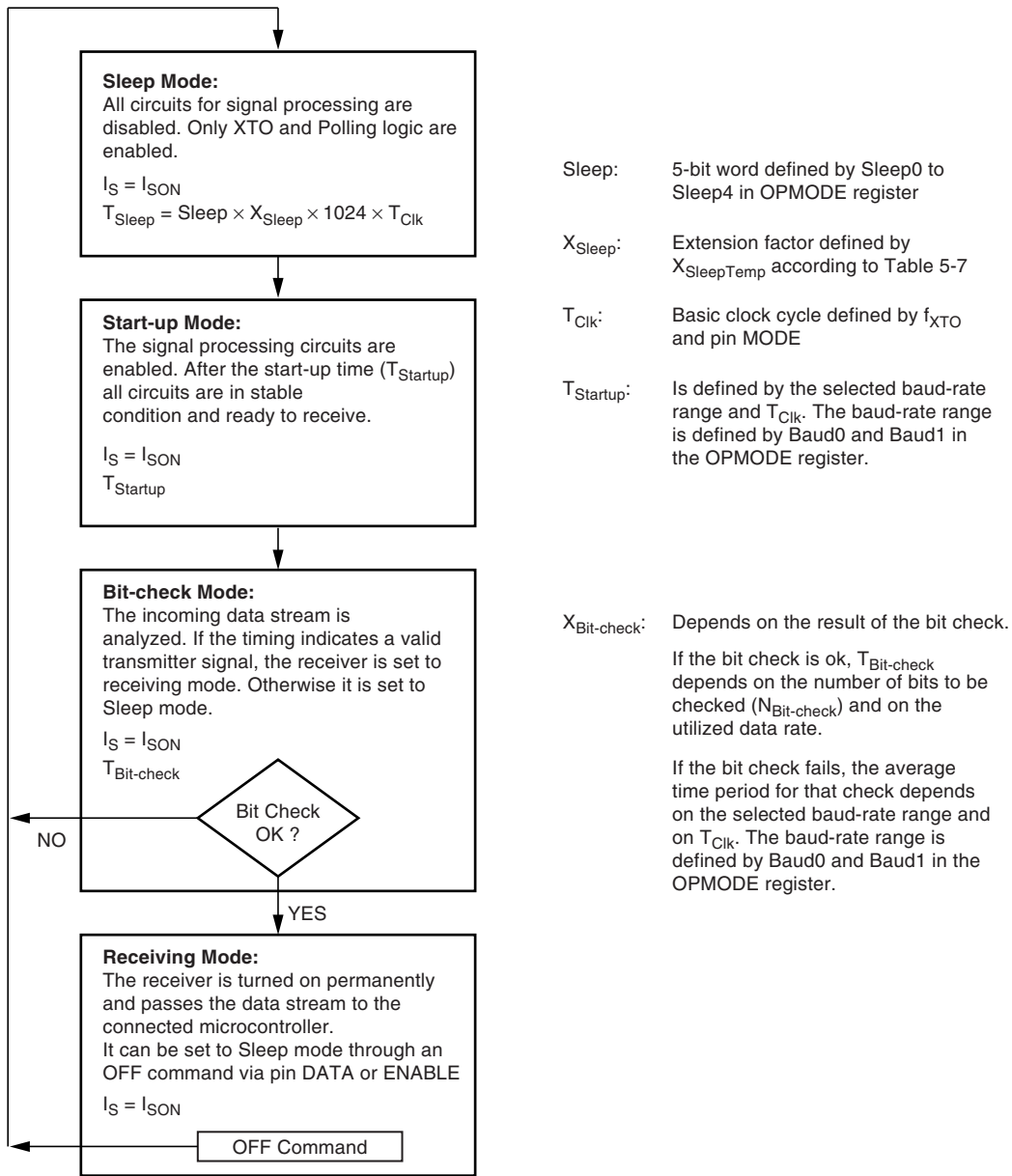
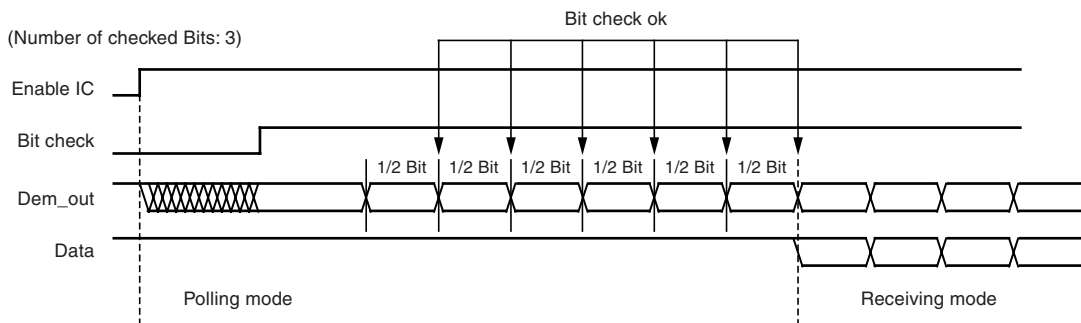

Figure 5-3. Timing Diagram for a Completely Successful Bit Check



5.3 Bit Check Mode

In bit check mode, the incoming data stream is examined to distinguish between a valid signal from a corresponding transmitter and signals due to noise. This is done by subsequent time frame checks where the distances between 2 signal edges are continuously compared to a programmable time window. The maximum count of this edge-to-edge test, before the receiver switches to receiving mode, is also programmable.

5.3.1 Configuring the Bit Check

Assuming a modulation scheme that contains 2 edges per bit, two time frame checks verify one bit. This is valid for Manchester, Bi-phase and most other modulation schemes. The maximum count of bits to be checked can be set to 0, 3, 6 or 9 bits via the variable N_{Bitcheck} in the OPMODE register. This implies 0, 6, 12 and 18 edge-to-edge checks respectively. If N_{Bitcheck} is set to a higher value, the receiver is less likely to switch to the receiving mode due to noise. In the presence of a valid transmitter signal, the bit check takes less time if N_{Bitcheck} is set to a lower value. In polling mode, the bit check time is not dependent on N_{Bitcheck} . [Figure 5-3 on page 12](#) shows an example where 3 bits are tested successfully and the data signal is transferred to pin DATA.

[Figure 5-4](#) shows that the time window for the bit check is defined by two separate time limits. If the edge-to-edge time t_{ee} is in between the lower bit check limit $T_{\text{Lim_min}}$ and the upper bit check limit $T_{\text{Lim_max}}$, the check will be continued. If t_{ee} is smaller than $T_{\text{Lim_min}}$ or t_{ee} exceeds $T_{\text{Lim_max}}$, the bit check will be terminated and the receiver switches to sleep mode.

Figure 5-4. Valid Time Window for Bit Check

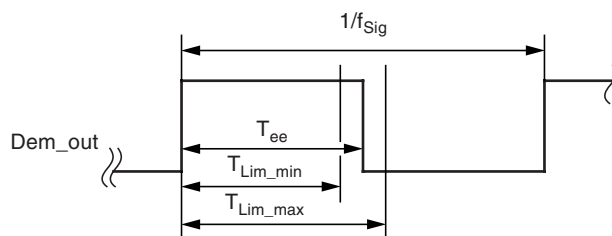

For best noise immunity it is recommended to use a low span between $T_{\text{Lim_min}}$ and $T_{\text{Lim_max}}$. This is achieved using a fixed frequency at a 50% duty cycle for the transmitter preburst. A “11111...” or a “10101...” sequence in Manchester or Bi-phase is a good choice in this regard. A good compromise between receiver sensitivity and susceptibility to noise is a time window of $\pm 25\%$ regarding the expected edge-to-edge time t_{ee} . Using preburst patterns that contain various edge-to-edge time periods, the bit check limits must be programmed according to the required span.

The bit check limits are determined by means of the formulas below:

$$T_{\text{Lim_min}} = \text{Lim_min} \times T_{\text{XClk}}$$

$$T_{\text{Lim_max}} = (\text{Lim_max} - 1) \times T_{\text{XClk}}$$

Lim_min and Lim_max are defined by a 5-bit word each within the LIMIT register.

Using the above formulas, Lim_min and Lim_max can be determined according to the required $T_{\text{Lim_min}}$, $T_{\text{Lim_max}}$ and T_{XClk} . The time resolution when defining $T_{\text{Lim_min}}$ and $T_{\text{Lim_max}}$ is T_{XClk} . The minimum edge-to-edge time t_{ee} ($t_{\text{DATA_L_min}}$, $t_{\text{DATA_H_min}}$) is defined in [Section “Receiving Mode” on page 15](#). Due to this, the lower limit should be set to $\text{Lim_min} \geq 10$. The maximum value of the upper limit is $\text{Lim_max} = 63$.

Figure 5-5, Figure 5-6 and Figure 5-7 illustrate the bit check for the default bit check limits $Lim_min = 14$ and $Lim_max = 24$. When the IC is enabled, the signal processing circuits are enabled during $T_{Startup}$. The output of the demodulator (Dem_out) is undefined during that period. When the bit check becomes active, the bit check counter is clocked with the cycle T_{XCLK} .

Figure 5-5 shows how the bit check proceeds if the bit-check counter value CV_Lim is within the limits defined by Lim_min and Lim_max at the occurrence of a signal edge. In Figure 5-7, the bit check fails as the value CV_lim is lower than the limit Lim_min . The bit check also fails if CV_Lim reaches Lim_max . This is illustrated in Figure 5-8 on page 15.

Figure 5-5. Timing Diagram During Bit Check

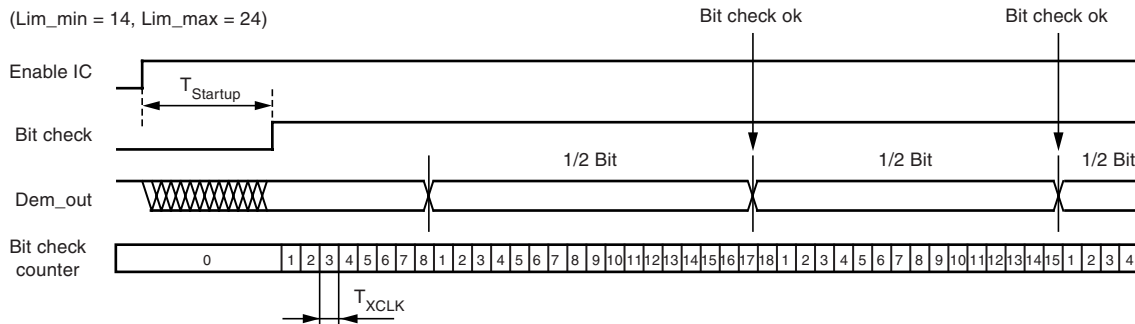

Figure 5-6. Timing Diagram for Failed Bit Check (Condition: $CV_Lim < Lim_min$)

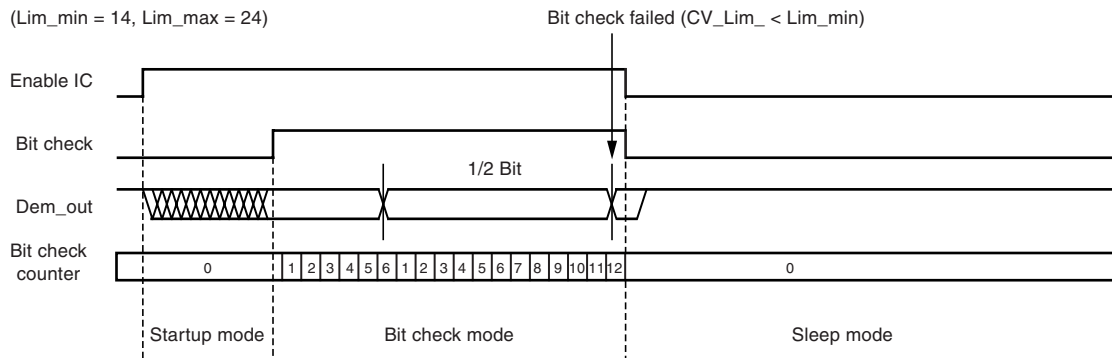
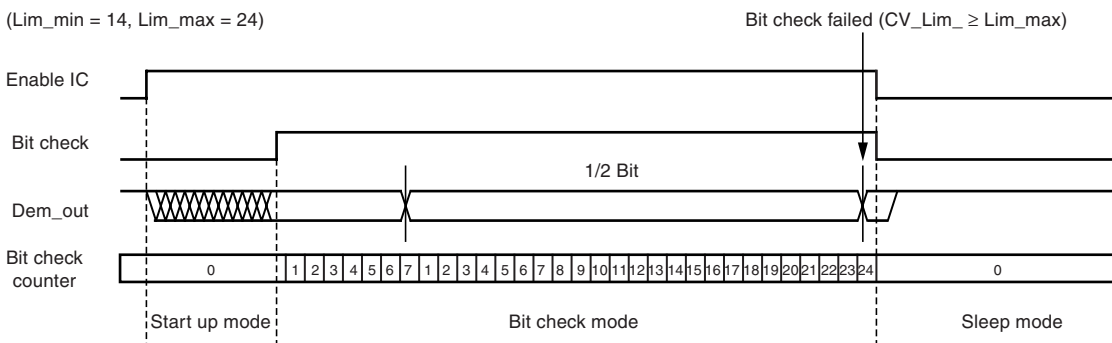

Figure 5-7. Timing Diagram for Failed Bit Check (Condition: $CV_Lim \geq Lim_max$)



5.3.2 Duration of the Bit Check

If no transmitter signal is present during the bit check, the output of the demodulator delivers random signals. The bit check is a statistical process and T_{Bitcheck} varies for each check. Therefore, an average value for T_{Bitcheck} is given in the section “[Electrical Characteristics](#)” on [page 23](#). T_{Bitcheck} depends on the selected baud rate range and on T_{Clk} . A higher baud rate range causes a lower value for T_{Bitcheck} resulting in lower current consumption in polling mode.

In the presence of a valid transmitter signal, T_{Bitcheck} is dependant on the frequency of that signal, f_{Sig} and the count of the checked bits, N_{Bitcheck} . A higher value for N_{Bitcheck} thereby results in a longer period for T_{Bitcheck} requiring a higher value for the transmitter preburst T_{Preburst} .

5.4 Receiving Mode

If the bit check has been successful for all bits specified by N_{Bitcheck} , the receiver switches to receiving mode. As seen in [Figure 5-4 on page 13](#), the internal data signal is switched to pin DATA in that case. A connected microcontroller can be woken up by the negative edge at pin DATA. The receiver stays in that condition until it is switched back to polling mode explicitly.

5.4.1 Digital Signal Processing

The data from the demodulator (Dem_out) is digitally processed in different ways and as a result converted into the output signal data. This processing depends on the selected baud rate range (BR_Range). [Figure 5-8](#) illustrates how Dem_out is synchronized by the extended clock cycle T_{XClk} . This clock is also used for the bit check counter. Data can change its state only after T_{XClk} elapsed. The edge-to-edge time period t_{ee} of the Data signal, as a result, is always an integral multiple of T_{XClk} .

The minimum time period between two edges of the data signal is limited to $t_{\text{ee}} \geq T_{\text{DATA_min}}$. This implies an efficient suppression of spikes at the DATA output. At the same time, it limits the maximum frequency of edges at DATA. This eases the interrupt handling of a connected microcontroller. $T_{\text{DATA_min}}$ is to some extent affected by the preceding edge-to-edge time interval t_{ee} as illustrated in [Figure 5-9 on page 16](#). If t_{ee} is in between the specified bit check limits, the following level is frozen for the time period $T_{\text{DATA_min}} = t_{\text{min1}}$; if t_{ee} is outside the bit check limits, $T_{\text{DATA_min}} = t_{\text{min2}}$ is the relevant stable time period.

The maximum time period for DATA to be low is limited to $T_{\text{DATA_L_max}}$. This function ensures a finite response time during programming or switching off the receiver via pin DATA. $T_{\text{DATA_L_max}}$ is thereby longer than the maximum time period indicated by the transmitter data stream. [Figure 5-10 on page 16](#) gives an example where Dem_out remains low after the receiver has switched to receiving mode.

Figure 5-8. Synchronization of the Demodulator Output

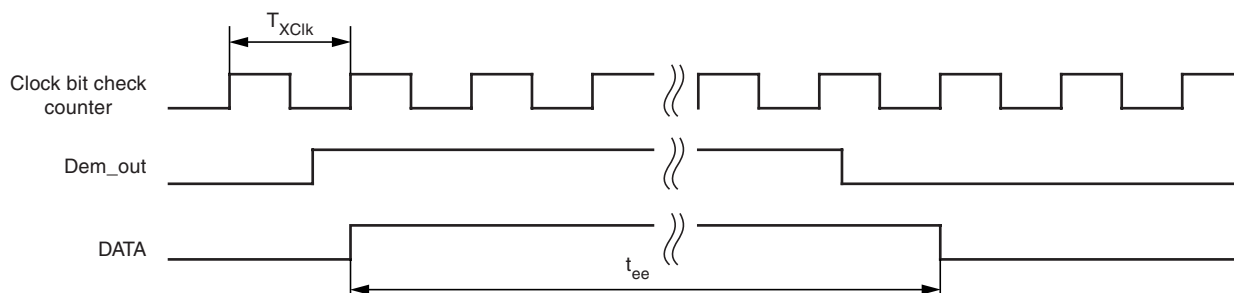

Figure 5-9. Debouncing of the Demodulator Output

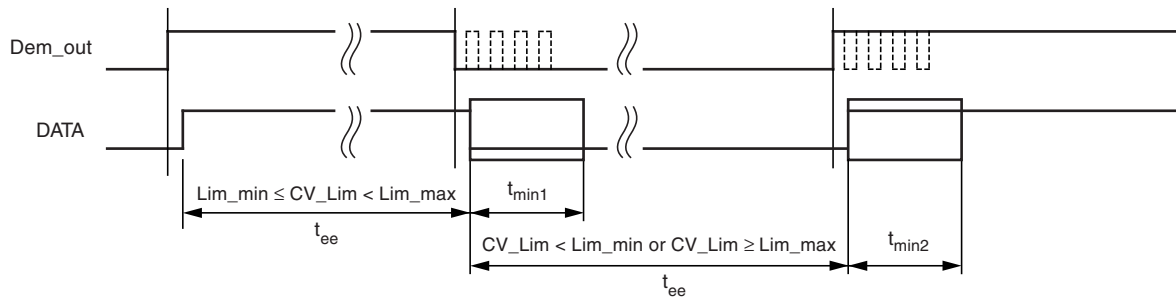
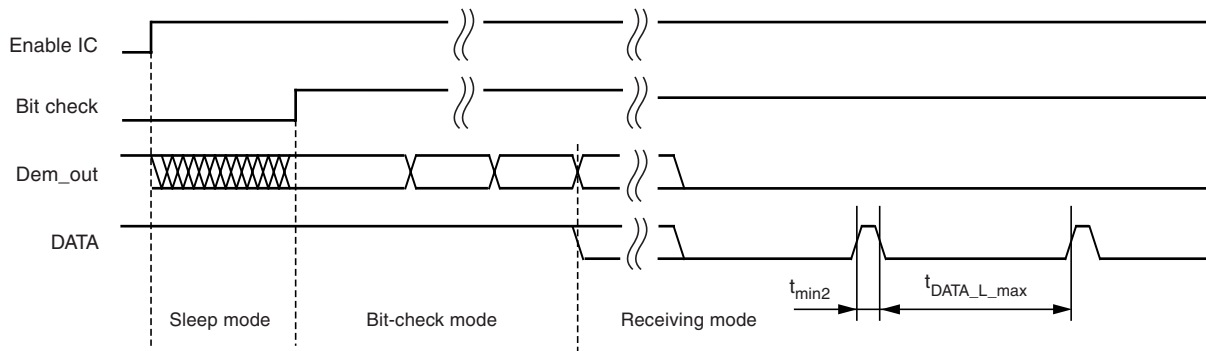

Figure 5-10. Steady L State Limited DATA Output Pattern after Transmission



After the end of a data transmission, the receiver remains active and random noise pulses appear at pin DATA. The edge-to-edge time period t_{ee} of the majority of these noise pulses is equal to or slightly higher than T_{DATA_min} .

5.4.2 Switching the Receiver Back to Sleep Mode

The receiver can be set back to polling mode via pin DATA or via pin ENABLE.

When using pin DATA, this pin must be pulled to low for the period t_1 by the connected microcontroller. [Figure 5-11 on page 17](#) illustrates the timing of the OFF command (see also [Figure 5-15 on page 22](#)). The minimum value of t_1 depends on the BR_Range. The maximum value for t_1 is not limited, but it is recommended not to exceed the specified value to prevent erasing the reset marker. This item is explained in more detail in [“Configuration of the Receiver” on page 18](#). Setting the receiver to sleep mode via DATA is achieved by programming bit 1 of the OPMODE register to “1”. Only one synchronous pulse (t_3) is issued.

The duration of the OFF command is determined by the sum of t_1 , t_2 and t_{10} . After the OFF command, the sleep time T_{Sleep} elapses. Note that the capacitive load at pin DATA is limited. The resulting time constant t together with an optional external pull-up resistor should not be exceeded, to ensure proper operation.

If the receiver is set to polling mode via pin ENABLE, an “L” pulse (T_{Doze}) must be issued at that pin. [Figure 5-12 on page 17](#) illustrates the timing of that command. After the positive edge of this pulse, the sleep time T_{Sleep} elapses. The receiver remains in sleep mode as long as ENABLE is held to “L”. If the receiver is polled exclusively by a microcontroller, T_{Sleep} can be programmed to “0” to enable an instantaneous response time. This command is the faster option than via pin DATA, at the cost of an additional connection to the microcontroller.

Figure 5-11. Timing Diagram of the OFF Command Via Pin DATA

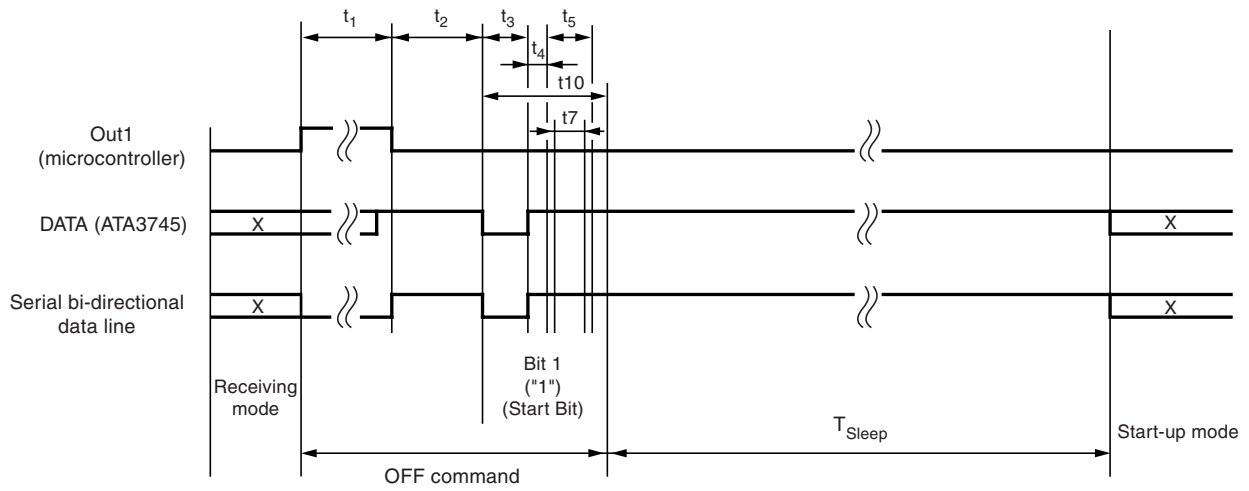
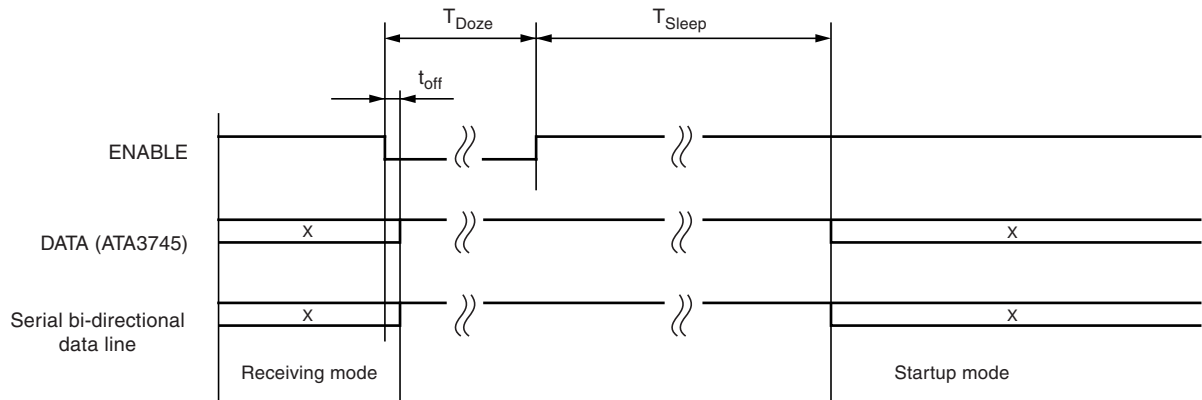

Figure 5-12. Timing Diagram of the OFF Command Via Pin ENABLE



5.5 Configuration of the Receiver

The ATA3745 receiver is configured via two 12-bit RAM registers called OPMODE and LIMIT. The registers can be programmed by means of the bi-directional DATA port. If the register contents have changed due to a voltage drop, this condition is indicated by a certain output pattern called reset marker (RM). The receiver must be reprogrammed in that case. After a power-on reset (POR), the registers are set to default mode. If the receiver is operated in default mode, there is no need to program the registers.

Table 5-2 shows the structure of the registers. Table 5-1 shows the effect of bit 1 and bit 2 in programming the registers: bit 1 defines if the receiver is set back to polling mode via the OFF command (see “Receiving Mode” on page 15), or if it is programmed. Bit 2 represents the register address. It selects the appropriate register to be programmed.

Table 5-1. Effect of Bit 1 and Bit 2 in Programming the Registers

Bit 1	Bit 2	Action
1	x	The receiver is set back to polling mode (OFF command)
0	1	The OPMODE register is programmed
0	0	The LIMIT register is programmed

Table 5-3 on page 19 and the following illustrate the effect of the individual configuration words. The default configuration is highlighted for each word.

BR_Range sets the appropriate baud rate range. At the same time it defines X_{Sleep}. X_{Sleep} is used to define the bit check limits T_{Lim_min} and T_{Lim_max} as shown in Table 5-3 on page 19.

POUT can be used to control the sensitivity of the receiver. In that application, POUT is set to “1” to reduce the sensitivity. This implies that the receiver operates with full sensitivity after a POR.

Table 5-2. Effect of the Configuration Words within the Registers

Bit1	Bit2	Bit2	Bit4	Bit5	Bit6	Bit7	Bit8	Bit9	Bit10	Bit11	Bit12	Bit13	Bit14
OFF Command													
1													
OPMODE Register													
0	1	BR_Range		N _{Bitcheck}		V _{POUT}	Sleep					X _{Sleep}	
0	1	Baud1	Baud0	BitChk1	BitChk0	POUT	Sleep4	Sleep3	Sleep2	Sleep1	Sleep0	X _{Sleep Std}	X _{Sleep Temp}
(Default)		0	0	1	0	0	0	1	0	1	1	0	0
LIMIT Register													
0	0	Lim_min						Lim_max					
0	0	Lim_min5	Lim_min4	Lim_min3	Lim_min2	Lim_min1	Lim_min0	Lim_max5	Lim_max4	Lim_max3	Lim_max2	Lim_max1	Lim_max0
(Default)		0	0	1	1	1	0	0	1	1	0	0	0

Table 5-3. Effect of the Configuration Word BR_Range

BR_Range		Baud Rate Range/Extension Factor for Bit Check Limits (XLim)
Baud1	Baud0	
0	0	BR_Range0 (application USA/Europe: BR_Range0 = 1.0 kBaud to 1.8 kBaud) (Default) XLim = 8 (Default)
0	1	BR_Range1 (application USA/Europe: BR_Range1 = 1.8 kBaud to 3.2 kBaud) XLim = 4
1	0	BR_Range2 (application USA/Europe: BR_Range2 = 3.2 kBaud to 5.6 kBaud) XLim = 2
1	1	BR_Range3 (application USA/Europe: BR_Range3 = 5.6 kBaud to 10 kBaud) XLim = 1

Table 5-4. Effect of the Configuration Word N_{Bitcheck}

N _{Bitcheck}		Number of Bits to be Checked
BitChk1	BitChk0	
0	0	0
0	1	3
1	0	6 (Default)
1	1	9

Table 5-5. Effect of the Configuration Bit VPOUT

VPOUT	Level of the Multi-purpose Output Port POUT
POUT	
0	0 (Default)
1	1

Table 5-6. Effect of the Configuration Word Sleep

Sleep					Start Value for Sleep Counter ($T_{Sleep} = Sleep \times X_{Sleep} \times 1024 \times T_{CLK}$)
Sleep4	Sleep3	Sleep2	Sleep1	Sleep0	
0	0	0	0	0	0 (Receiver is continuously polling until a valid signal occurs)
0	0	0	0	1	1 ($T_{Sleep} \approx 2$ ms for $X_{Sleep} = 1$ in US/European applications)
0	0	0	1	0	2
0	0	0	1	1	3
.
.
.
0	1	0	1	1	11 (USA: $T_{Sleep} = 22.96$ ms, Europe: $T_{Sleep} = 23.31$ ms) (Default)
.
.
.
1	1	1	0	1	29
1	1	1	1	0	30
1	1	1	1	1	31 (Permanent sleep mode)

Table 5-7. Effect of the Configuration Word X_{Sleep}

X_{Sleep}		Extension Factor for Sleep Time ($T_{Sleep} = Sleep \times X_{Sleep} \times 1024 \times T_{Clk}$)
$X_{SleepStd}$	$X_{SleepTemp}$	
0	0	1 (Default)
0	1	8 (X_{Sleep} is reset to 1 if bit check fails once)
1	0	8 (X_{Sleep} is set permanently)
1	1	8 (X_{Sleep} is set permanently)

Table 5-8. Effect of the Configuration Word Lim_min

Lim_min						Lower Limit Value for Bit Check
$Lim_min < 10$ is not applicable						$(T_{Lim_min} = Lim_min \times X_{Lim} \times T_{Clk})$
0	0	1	0	1	0	10
0	0	1	0	1	1	11
0	0	1	1	0	0	12
0	0	1	1	0	1	13
0	0	1	1	1	0	14 (Default) (USA: $T_{Lim_min} = 228 \mu s$, Europe: $T_{Lim_min} = 232 \mu s$)
.
.
.
1	1	1	1	0	1	61
1	1	1	1	1	0	62
1	1	1	1	1	1	63

Table 5-9. Effect of the Configuration Word Lim_max

Lim_max						Upper Limit Value for Bit Check
$Lim_max < 12$ is not applicable						$(T_{Lim_max} = (Lim_max - 1) \times X_{Lim} \times T_{Clk})$
0	0	1	1	0	0	12
0	0	1	1	0	1	13
0	0	1	1	1	0	14
.
.
.
0	1	1	0	0	0	24 (Default) (USA: $T_{Lim_max} = 375 \mu s$, Europe: $T_{Lim_max} = 381 \mu s$)
.
.
.
1	1	1	1	0	1	61
1	1	1	1	1	0	62
1	1	1	1	1	1	63

5.5.1 Conservation of the Register Information

The ATA3745 has integrated power-on reset and brown-out detection circuitry to provide a mechanism to preserve the RAM register information.

According to [Figure 5-13](#), a power-on reset (POR) is generated if the supply voltage V_S drops below the threshold voltage $V_{ThReset}$. The default parameters are programmed into the configuration registers in that condition. Once V_S exceeds $V_{ThReset}$, the POR is canceled after the minimum reset period t_{Rst} . A POR is also generated when the supply voltage of the receiver is turned on.

To indicate that condition, the receiver displays a reset marker (RM) at pin DATA after a reset. The RM is represented by the fixed frequency f_{RM} at a 50% duty cycle. RM can be canceled via an "L" pulse t_1 at pin DATA. The RM implies the following characteristics:

- f_{RM} is lower than the lowest feasible frequency of a data signal. By this means, RM cannot be misinterpreted by the connected microcontroller.
- If the receiver is set back to polling mode via pin DATA, RM cannot be canceled by accident if t_1 is applied according to the proposal in ["Programming the Configuration Register"](#) on [page 22](#).

By means of that mechanism, the receiver cannot lose its register information without communicating that condition via the reset marker RM.

Figure 5-13. Generation of the Power-on Reset

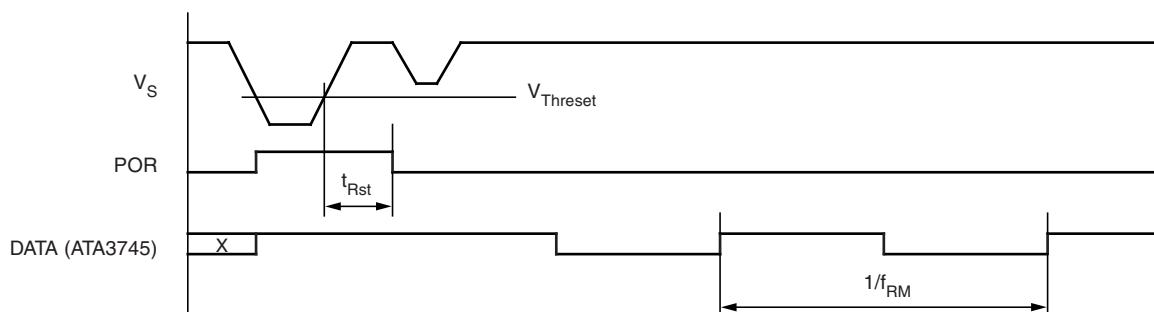
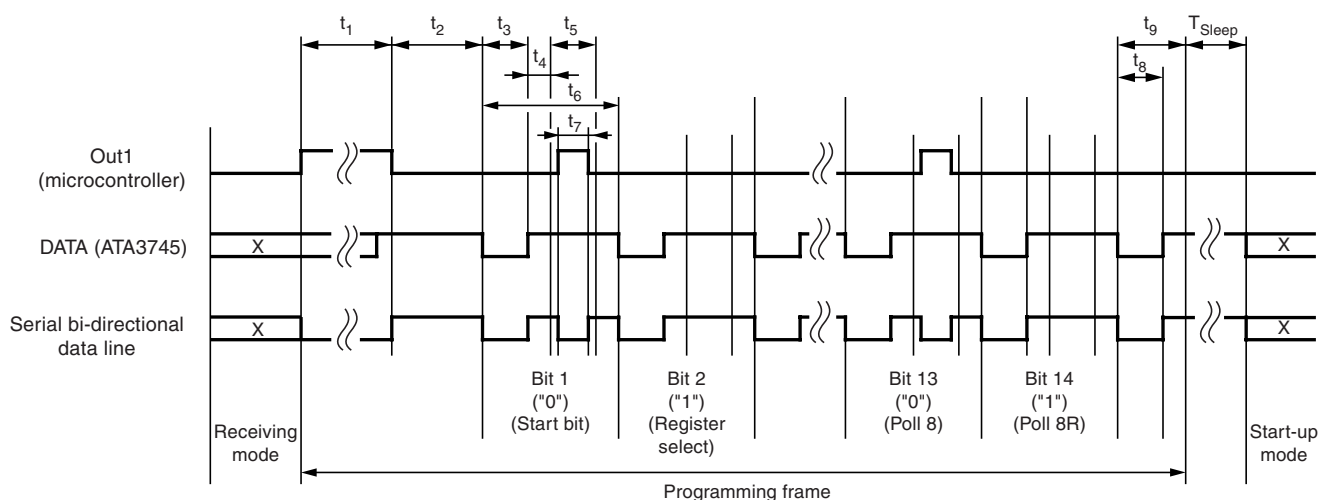

Figure 5-14. Timing of the Register Programming



5.5.2 Programming the Configuration Register

The configuration registers are programmed serially via the bi-directional data line according to Figure 5-14 on page 21 and Figure 5-15.

Figure 5-15. One-wire Connection to a Microcontroller

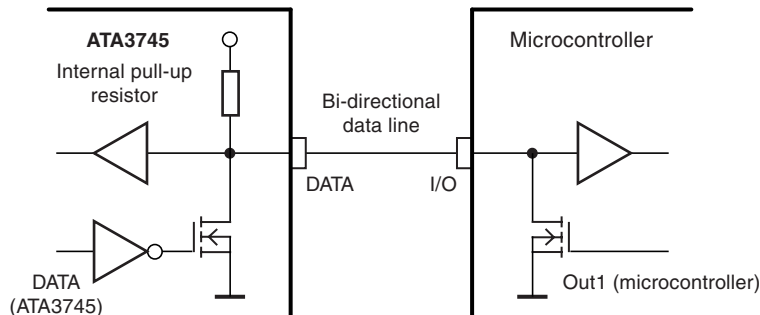

To start programming, the serial data line DATA is pulled by the microcontroller to “L” for the time period t_1 . When DATA has been released, the receiver becomes the master device. When the programming delay period t_2 has elapsed, it emits 14 subsequent synchronization pulses with the pulse length t_3 . After each of these pulses, a programming window occurs. The delay until the program window starts is determined by t_4 , the duration is defined by t_5 . Within the programming window, the individual bits are set. If the microcontroller pulls down pin DATA for the time period t_7 during t_5 , the corresponding bit is set to “0”. If no programming pulse t_7 is issued, this bit is set to “1”. All 14 bits are subsequently programmed in this way. The time frame to program a bit is defined by t_6 .

Bit 14 is followed by the equivalent time window t_9 . During this window, the equivalent acknowledge pulse t_8 (E_Ack) occurs if the mode word just programmed is equivalent to the mode word that was already stored in that register. E_Ack should be used to verify that the mode word was correctly transferred to the register. The register must be programmed twice in that case.

Programming of a register is possible both during sleep and active mode of the receiver. During programming, the LNA, LO, low-pass filter, IF amplifier and the demodulator are disabled.

The programming start pulse t_1 initiates the programming of the configuration registers. If bit 1 is set to “1”, it represents the OFF command, setting the receiver back to polling mode at the same time. For the length of the programming start pulse t_1 , the following convention should be considered:

- $t_1(\text{min}) < t_1 < 1535 \times T_{\text{Clk}}$: [$t_1(\text{min})$ is the minimum specified value for the relevant BR_Range]

Programming (or the OFF command) is initiated if the receiver is not in reset mode. If the receiver is in reset mode, programming (or the OFF command) is not initiated, and the reset marker RM is still present at pin DATA. This period is generally used to switch the receiver to polling mode. In a reset condition, RM is not canceled by accident.

- $t_1 > 5632 \times T_{\text{Clk}}$

Programming (or the OFF command) is initiated in any case. RM is cancelled if present. This period is used if the connected microcontroller detected RM. If a configuration register is programmed, this time period for t_1 can generally be used. Note that the capacitive load at pin DATA is limited. The resulting time constant t together with an optional external pull-up resistor may not be exceeded to ensure proper operation.

6. Absolute Maximum Ratings

Stresses beyond those listed under “Absolute Maximum Ratings” may cause permanent damage to the device. This is a stress rating only and functional operation of the device at these or any other conditions beyond those indicated in the operational sections of this specification is not implied. Exposure to absolute maximum rating conditions for extended periods may affect device reliability.

Parameters	Symbol	Min.	Max.	Unit
Supply voltage	V_S		6	V
Power dissipation	P_{tot}		450	mW
Junction temperature	T_j		150	°C
Storage temperature	T_{stg}	-55	+125	°C
Ambient temperature	T_{amb}	-40	+85	°C
Maximum input level, input matched to 50Ω	P_{in_max}		10	dBm

7. Thermal Resistance

Parameters	Symbol	Value	Unit
Junction ambient	R_{thJA}	100	K/W

8. Electrical Characteristics

All parameters refer to GND, $V_S = 5V$, $T_{amb} = 25^\circ C$, $f_0 = 433.92$ MHz and $f_0 = 315$ MHz, unless otherwise specified. The possible operating range refer to different circuit conditions: $V_S = 4.5V$ to $5.5V$, $T_{amb} = -40^\circ C$ to $+85^\circ C$

Parameters	Test Conditions	Symbol	Min.	Typ.	Max.	Unit
Current consumption	Sleep mode (XTO and polling logic active)	$I_{S_{off}}$		190	350	μA
	IC active (startup, bit check, or receiving mode) Pin DATA = H	$I_{S_{on}}$		7.0	8.6	mA
LNA Mixer						
Third-order intercept point	LNA/mixer/IF amplifier input matched according to Figure 3-3 on page 6	IIP3		-28		dBm
LO spurious emission at RF_{in}	Input matched according to Figure 3-3 on page 6 , required according to I-ETS 300220	IS_{LORF}		-73	-57	dBm
Noise figure LNA and mixer (DSB)	Input matching according to Figure 3-3 on page 6	NF		7		dB
LNA_IN input impedance	at 433.92 MHz at 315 MHz	$Z_{i_{LNA_IN}}$		1.0 1.56 1.3 1.0		kΩ pF kΩ pF
1 dB compression point (LNA, mixer, IF amplifier)	Input matched according to Figure 3-3 on page 6 , referred to RF_{in}	IP_{1db}		-40		dBm
Maximum input level	Input matched according to Figure 3-3 on page 6 , BER $\leq 10^{-3}$, ASK mode	P_{in_max}			-23	dBm

8. Electrical Characteristics (Continued)

All parameters refer to GND, $V_S = 5V$, $T_{amb} = 25^\circ C$, $f_0 = 433.92$ MHz and $f_0 = 315$ MHz, unless otherwise specified. The possible operating range refer to different circuit conditions: $V_S = 4.5V$ to $5.5V$, $T_{amb} = -40^\circ C$ to $+85^\circ C$

Parameters	Test Conditions	Symbol	Min.	Typ.	Max.	Unit
Local Oscillator						
Operating frequency range VCO		f_{VCO}	309		439	MHz
Loop bandwidth of the PLL	For best LO noise (design parameter) $R1 = 820\Omega$ $C9 = 4.7$ nF $C10 = 1$ nF	B_{Loop}		100		kHz
Capacitive load at pin LF	The capacitive load at pin LF is limited if bit check is used. The limitation therefore also applies to self polling.	C_{LF_tot}			10	nF
XTO operating frequency	XTO crystal frequency, appropriate load capacitance must be connected to XTAL 6.764375 MHz	f_{XTO}	6.764375	6.764375	6.764375	MHz
	4.90625 MHz		-50 ppm 4.90625 -50 ppm		+50 ppm 4.90625 +50 ppm	MHz
Series resonance resistor of the crystal	$f_{XTO} = 6.764$ MHz 4.906 MHz	R_S			150 220	Ω Ω
Static capacitance at pin XTO		C_{XTO}			6.5	pF
Analog Signal Processing						
Input sensitivity ASK 600-kHz IF filter	Input matched according to Figure 5-1 ASK (level of carrier) $BER \leq 10^{-3}$, $B = 600$ kHz $f_{in} = 433.92$ MHz/315 MHz $T = 25^\circ C$, $V_S = 5V$ $f_{IF} = 1$ MHz	P_{Ref_ASK}				
	BR_Range0		-106	-110	-113.5	dBm
	BR_Range1		-104.5	-108.5	-112	dBm
	BR_Range2		-104	-108	-111.5	dBm
	BR_Range3		-102	-106	-109.5	dBm
Sensitivity variation ASK for full operating range including IF filter compared to $T_{amb} = 25^\circ C$, $V_S = 5V$	600-kHz version $f_{in} = 433.92$ MHz/315 MHz $f_{IF} = 0.81$ MHz to 1.19 MHz $f_{IF} = 0.75$ MHz to 1.25 MHz $P_{ASK} = P_{Ref_ASK} + \Delta P_{Ref}$	ΔP_{Ref}	+3 +5			dB dB
SNR to suppress in-band noise signals	ASK mode	SNR_{ASK}		11		dB
Dynamic range RSSI ampl.		ΔR_{RSSI}		60		dB
Lower cut-off frequency of the data filter	$f_{cu_DF} = \frac{1}{2 \times \pi \times 30k\Omega \times CDEM}$ $CDEM = 33$ nF	f_{cu_DF}	0.11	0.16	0.20	kHz

8. Electrical Characteristics (Continued)

All parameters refer to GND, $V_S = 5V$, $T_{amb} = 25^\circ C$, $f_0 = 433.92\text{ MHz}$ and $f_0 = 315\text{ MHz}$, unless otherwise specified. The possible operating range refer to different circuit conditions: $V_S = 4.5V$ to $5.5V$, $T_{amb} = -40^\circ C$ to $+85^\circ C$

Parameters	Test Conditions	Symbol	Min.	Typ.	Max.	Unit
Recommended CDEM for best performance	ASK mode	CDEM				nF
	BR_Range0 (Default)					
	BR_Range1					
	BR_Range2					
	BR_Range3					nF
Maximum edge-to-edge time period of the input data signal for full sensitivity	BR_Range0 (Default)	t_{ee_sig}				μs
	BR_Range1					
	BR_Range2					
	BR_Range3					
Minimum edge-to-edge time period of the input data signal for full sensitivity	BR_Range0 (Default)	t_{ee_sig}				μs
	BR_Range1					
	BR_Range2					
	BR_Range3					
Threshold voltage for reset		$V_{ThRESET}$	1.95	2.8	3.75	V
Digital Ports						
Data output - Saturation voltage LOW - Internal pull-up resistor - Maximum time constant - Maximum capacitive load	$I_{OI} = 1\text{ mA}$ $\tau = C_L (R_{PUP} // R_{EXT})$ without external pull-up resistor $R_{EXT} = 5\text{ k}\Omega$	V_{OI} R_{PUP} τ C_L C_L	39	0.08 50	0.3 61	V k Ω μs pF pF
POUT output - Saturation voltage LOW - Saturation voltage HIGH	$I_{POUT} = 1\text{ mA}$ $I_{POUT} = -1\text{ mA}$	V_{OI} V_{Oh}	$V_S - 0.3V$	0.08 $V_S - 0.14V$	0.3	V V
ASK input - High-level input voltage	ASK	V_{Ih}	$0.8 \times V_S$			V
ENABLE input - Low-level input voltage - High-level input voltage	Idle mode Active mode	V_{Il} V_{Ih}	$0.8 \times V_S$		$0.2 \times V_S$	V V
MODE input - Low-level input voltage - High-level input voltage	Division factor = 10 Division factor = 14	V_{Il} V_{Ih}	$0.8 \times V_S$		$0.2 \times V_S$	V V
TEST input - Low-level input voltage	Test input must always be set to LOW	V_{Il}			$0.2 \times V_S$	V

9. Electrical Characteristics

All parameters refer to GND, $V_S = 5V$, $T_{amb} = 25^\circ C$, $f_0 = 433.92$ MHz and $f_0 = 315$ MHz, unless otherwise specified. The possible operating range refer to different circuit conditions: $V_S = 4.5V$ to $5.5V$, $T_{amb} = -40^\circ C$ to $+85^\circ C$

Parameter	Test Condition	Symbol	6.76438-Mhz Oscillator (Mode 1)			4.90625-Mhz Oscillator (Mode 0)			Variable Oscillator			Unit	
			Min.	Typ.	Max.	Min.	Typ.	Max.	Min.	Typ.	Max.		
Basic Clock Cycle of the Digital Circuitry													
Basic clock cycle	MODE = 0 (USA) MODE = 1 (Europe)	T_{Clk}		2.0697			2.0383			$1 / (f_{XTO} / 10)$ $1 / (f_{XTO} / 14)$		μs μs	
Extended basic clock cycle	BR_Range0	T_{XClk}		16.6			16.3			$8 \times T_{Clk}$		μs	
	BR_Range1			8.3			8.2			$4 \times T_{Clk}$		μs	
	BR_Range2			4.1			4.1			$2 \times T_{Clk}$		μs	
	BR_Range3			2.1			2.0			$1 \times T_{Clk}$		μs	
Polling Mode													
Sleep time	Sleep and X_{Sleep} are defined in the OPMODE register	T_{Sleep}		$Sleep \times X_{Sleep} \times 1024 \times 2.0697$			$Sleep \times X_{Sleep} \times 1024 \times 2.0383$			$Sleep \times X_{Sleep} \times 1024 \times T_{Clk}$		ms	
Start-up time	BR_Range0	$T_{Startup}$		1855			1827			896.5		μs	
	BR_Range1			1061			1045			512.5		μs	
	BR_Range2			1061			1045			512.5		μs	
	BR_Range3			663			653			$320.5 \times T_{Clk}$		μs	
Time for Bit check	Average bit check time while polling BR_Range0 BR_Range1 BR_Range2 BR_Range3	$T_{Bitcheck}$		0.45			0.47					ms	
				0.24			0.26					ms	
				0.14			0.16					ms	
				0.14			0.15					ms	
		Bit check time for a valid input signal f_{Sig} $N_{Bitcheck} = 0$ $N_{Bitcheck} = 3$ $N_{Bitcheck} = 6$ $N_{Bitcheck} = 9$	$T_{Bitcheck}$	$3 / f_{Sig}$ $6 / f_{Sig}$ $9 / f_{Sig}$			$3.5 / f_{Sig}$ $6.5 / f_{Sig}$ $9.5 / f_{Sig}$	$3 / f_{Sig}$ $6 / f_{Sig}$ $9 / f_{Sig}$			T_{XClk}	$3.5 / f_{Sig}$ $6.5 / f_{Sig}$ $9.5 / f_{Sig}$	ms ms ms ms
Receiving Mode													
Intermediate frequency	MODE = 0 (USA) MODE = 1 (Europe)	f_{IF}		1.0			1.0			$f_{XTO} \times 64 / 314$ $f_{XTO} \times 64 / 432.92$		MHz MHz	
Baud rate range	BR_Range0	BR_Range	1.0			1.8	1.0		1.8	$BR_Range0 \times 2 \text{ ms} / T_{Clk}$ $BR_Range1 \times 2 \text{ ms} / T_{Clk}$ $BR_Range2 \times 2 \text{ ms} / T_{Clk}$ $BR_Range3 \times 2 \text{ ms} / T_{Clk}$		kBaud	
	BR_Range1		1.8			3.2	1.8		3.2		kBaud		
	BR_Range2		3.2			5.6	3.2		5.6		kBaud		
	BR_Range3		5.6			10.0	5.6		10.0		kBaud		
Minimum time period between edges at pin DATA (Figure 5-9 on page 16)	BR_Range0	T_{DATA_min} tmin1 tmin2		149 182			147 179			$9 \times T_{XClk}$ $11 \times T_{XClk}$		μs μs	
	BR_Range1			75 91			73 90			$9 \times T_{XClk}$ $11 \times T_{XClk}$		μs μs	
	BR_Range2	tmin1 tmin2		37.3 45.5			36.7 44.8			$9 \times T_{XClk}$ $11 \times T_{XClk}$		μs μs	
	BR_Range3			18.6 22.8			18.3 22.4			$9 \times T_{XClk}$ $11 \times T_{XClk}$		μs μs	
	Maximum low period at DATA (Figure 5-10 on page 16)	BR_Range0	$T_{DATA_L_max}$		2169			2136			$131 \times T_{XClk}$		μs
		BR_Range1			1085			1068			$131 \times T_{XClk}$		μs
		BR_Range2			542			534			$131 \times T_{XClk}$		μs
		BR_Range3			271			267			$131 \times T_{XClk}$		μs

9. Electrical Characteristics

All parameters refer to GND, $V_S = 5V$, $T_{amb} = 25^\circ C$, $f_0 = 433.92\text{ MHz}$ and $f_0 = 315\text{ MHz}$, unless otherwise specified. The possible operating range refer to different circuit conditions: $V_S = 4.5V$ to $5.5V$, $T_{amb} = -40^\circ C$ to $+85^\circ C$

Parameter	Test Condition	Symbol	6.76438-Mhz Oscillator (Mode 1)			4.90625-Mhz Oscillator (Mode 0)			Variable Oscillator			Unit
			Min.	Typ.	Max.	Min.	Typ.	Max.	Min.	Typ.	Max.	
OFF command at pin ENABLE (Figure 5-12 on page 17)		t_{Doze}	3.1			3.05			$1.5 \times T_{Clk}$			μs
Configuration of the Receiver												
Frequency of the reset marker (Figure 5-13 on page 21)		f_{RM}		117.9			119.8			$\frac{1}{4096 \times T_{CLK}}$		Hz
Programming start pulse (Figure 5-11 on page 17, Figure 5-14 on page 21)	BR_Range0	t_1	2188		3176	2155		3128	$1057 \times T_{Clk}$		$1535 \times T_{Clk}$	μs
	BR_Range1		1104		3176	1087		3128	$533 \times T_{Clk}$		$1535 \times T_{Clk}$	
	BR_Range2		561		3176	553		3128	$271 \times T_{Clk}$		$1535 \times T_{Clk}$	
	BR_Range3		290		3176	286		3128	$140 \times T_{Clk}$		$1535 \times T_{Clk}$	
	after POR		11656			11479			$5632 \times T_{Clk}$			
Programming delay period (Figure 5-11 on page 17, Figure 5-14 on page 21)		t_2	795		798	783		786	$384.5 \times T_{Clk}$		$385.5 \times T_{Clk}$	μs
Synchron- ization pulse (Figure 5-11 on page 17, Figure 5-14 on page 21)		t_3		265			261			$128 \times T_{Clk}$		μs
Delay until the program window starts (Figure 5-11 on page 17, Figure 5-14 on page 21)		t_4		131			129			$63.5 \times T_{Clk}$		μs
Programming window (Figure 5-11 on page 17, Figure 5-14 on page 21)		t_5		530			522			$256 \times T_{Clk}$		μs
Time frame of a bit (Figure 5-14 on page 21)		t_6		1060			1044			$512 \times T_{Clk}$		μs

9. Electrical Characteristics

All parameters refer to GND, $V_S = 5V$, $T_{amb} = 25^\circ C$, $f_0 = 433.92\text{ MHz}$ and $f_0 = 315\text{ MHz}$, unless otherwise specified. The possible operating range refer to different circuit conditions: $V_S = 4.5V$ to $5.5V$, $T_{amb} = -40^\circ C$ to $+85^\circ C$

Parameter	Test Condition	Symbol	6.76438-Mhz Oscillator (Mode 1)			4.90625-Mhz Oscillator (Mode 0)			Variable Oscillator			Unit
			Min.	Typ.	Max.	Min.	Typ.	Max.	Min.	Typ.	Max.	
Programming pulse (Figure 5-11 on page 17, Figure 5-14 on page 21)		t7	133		529	131		521	$64 \times T_{Clk}$		$256 \times T_{Clk}$	μs
Equivalent acknowledge pulse: E_Ack (Figure 5-14 on page 21)		t8		265			261			$128 \times T_{Clk}$		μs
Equivalent time window (Figure 5-14 on page 21)		t9		534			526			$258 \times T_{Clk}$		μs
OFF bit programming window (Figure 5-11 on page 17)		t10		930			916			$449.5 \times T_{Clk}$		μs

10. Ordering Information

Extended Type Number	Package	Remarks
ATA3745P3-TGQY	SO20	Taped and reeled, Pb-free

11. Package Information

Package SO20

Dimensions in mm

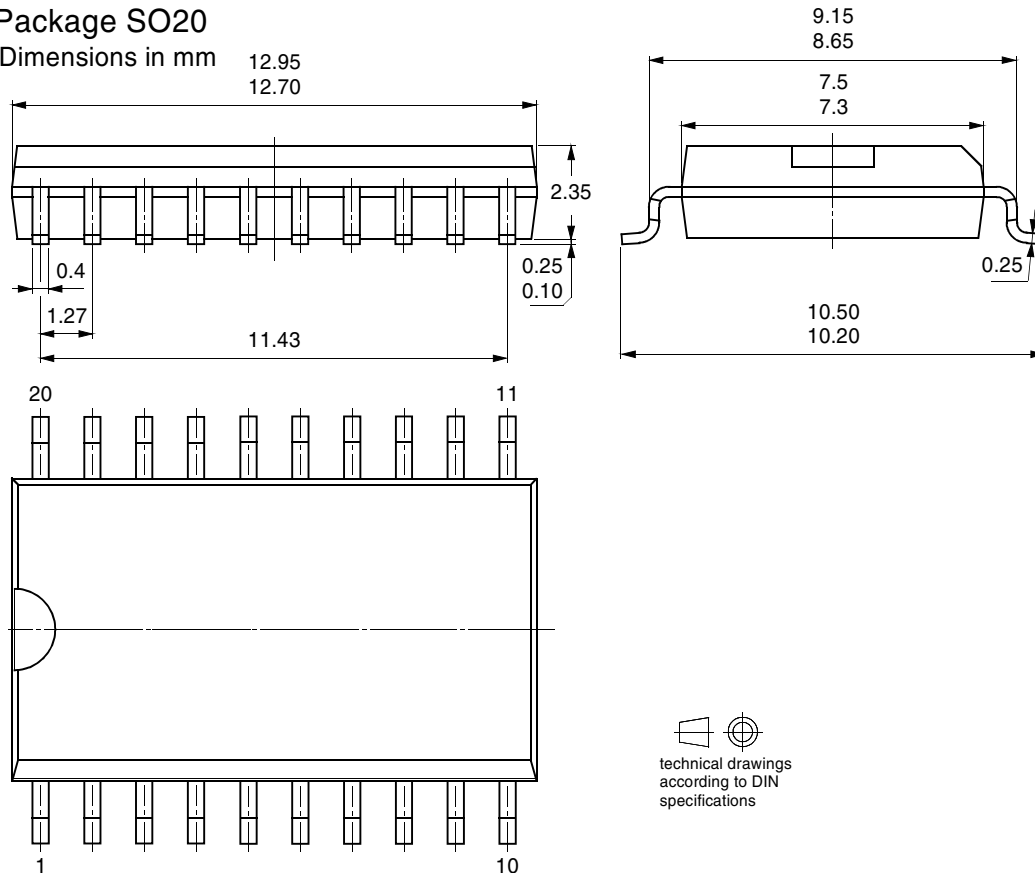

technical drawings
according to DIN
specifications

12. Revision History

Please note that the following page numbers referred to in this section refer to the specific revision mentioned, not to this document.

Revision No.	History
4901B-RKE-11/07	• Put datasheet in the newest template



Headquarters

Atmel Corporation
2325 Orchard Parkway
San Jose, CA 95131
USA
Tel: 1(408) 441-0311
Fax: 1(408) 487-2600

International

Atmel Asia
Room 1219
Chinachem Golden Plaza
77 Mody Road Tsimshatsui
East Kowloon
Hong Kong
Tel: (852) 2721-9778
Fax: (852) 2722-1369

Atmel Europe
Le Krebs
8, Rue Jean-Pierre Timbaud
BP 309
78054
Saint-Quentin-en-Yvelines Cedex
France
Tel: (33) 1-30-60-70-00
Fax: (33) 1-30-60-71-11

Atmel Japan
9F, Tonetsu Shinkawa Bldg.
1-24-8 Shinkawa
Chuo-ku, Tokyo 104-0033
Japan
Tel: (81) 3-3523-3551
Fax: (81) 3-3523-7581

Product Contact

Web Site
www.atmel.com

Technical Support
auto_control@atmel.com

Sales Contact
www.atmel.com/contacts

Literature Requests
www.atmel.com/literature

Disclaimer: The information in this document is provided in connection with Atmel products. No license, express or implied, by estoppel or otherwise, to any intellectual property right is granted by this document or in connection with the sale of Atmel products. **EXCEPT AS SET FORTH IN ATMEL'S TERMS AND CONDITIONS OF SALE LOCATED ON ATMEL'S WEB SITE, ATMEL ASSUMES NO LIABILITY WHATSOEVER AND DISCLAIMS ANY EXPRESS, IMPLIED OR STATUTORY WARRANTY RELATING TO ITS PRODUCTS INCLUDING, BUT NOT LIMITED TO, THE IMPLIED WARRANTY OF MERCHANTABILITY, FITNESS FOR A PARTICULAR PURPOSE, OR NON-INFRINGEMENT. IN NO EVENT SHALL ATMEL BE LIABLE FOR ANY DIRECT, INDIRECT, CONSEQUENTIAL, PUNITIVE, SPECIAL OR INCIDENTAL DAMAGES (INCLUDING, WITHOUT LIMITATION, DAMAGES FOR LOSS OF PROFITS, BUSINESS INTERRUPTION, OR LOSS OF INFORMATION) ARISING OUT OF THE USE OR INABILITY TO USE THIS DOCUMENT, EVEN IF ATMEL HAS BEEN ADVISED OF THE POSSIBILITY OF SUCH DAMAGES.** Atmel makes no representations or warranties with respect to the accuracy or completeness of the contents of this document and reserves the right to make changes to specifications and product descriptions at any time without notice. Atmel does not make any commitment to update the information contained herein. Unless specifically provided otherwise, Atmel products are not suitable for, and shall not be used in, automotive applications. Atmel's products are not intended, authorized, or warranted for use as components in applications intended to support or sustain life.

© 2007 Atmel Corporation. All rights reserved. Atmel®, logo and combinations thereof, and others are registered trademarks or trademarks of Atmel Corporation or its subsidiaries. Other terms and product names may be trademarks of others.

Данный компонент на территории Российской Федерации

Вы можете приобрести в компании MosChip.

Для оперативного оформления запроса Вам необходимо перейти по данной ссылке:

<http://moschip.ru/get-element>

Вы можете разместить у нас заказ для любого Вашего проекта, будь то серийное производство или разработка единичного прибора.

В нашем ассортименте представлены ведущие мировые производители активных и пассивных электронных компонентов.

Нашей специализацией является поставка электронной компонентной базы двойного назначения, продукции таких производителей как XILINX, Intel (ex.ALTERA), Vicor, Microchip, Texas Instruments, Analog Devices, Mini-Circuits, Amphenol, Glenair.

Сотрудничество с глобальными дистрибьюторами электронных компонентов, предоставляет возможность заказывать и получать с международных складов практически любой перечень компонентов в оптимальные для Вас сроки.

На всех этапах разработки и производства наши партнеры могут получить квалифицированную поддержку опытных инженеров.

Система менеджмента качества компании отвечает требованиям в соответствии с ГОСТ Р ИСО 9001, ГОСТ РВ 0015-002 и ЭС РД 009

Офис по работе с юридическими лицами:

105318, г.Москва, ул.Щербаковская д.3, офис 1107, 1118, ДЦ «Щербаковский»

Телефон: +7 495 668-12-70 (многоканальный)

Факс: +7 495 668-12-70 (доб.304)

E-mail: info@moschip.ru

Skype отдела продаж:

moschip.ru

moschip.ru_4

moschip.ru_6

moschip.ru_9