

Docs » Get Started » ESP32-DevKitC V4 Getting Started Guide

ESP32-DevKitC V4 Getting Started Guide

[\[中文\]](#)

This user guide shows how to get started with ESP32-DevKitC V4 development board. For description of other versions of the ESP32-DevKitC check [ESP32 Hardware Reference](#).

What You Need

- 1 × [ESP32-DevKitC V4 board](#)
- 1 × USB A / micro USB B cable
- 1 × PC loaded with Windows, Linux or Mac OS

Overview

ESP32-DevKitC V4 is a small-sized ESP32-based development board produced by Espressif. Most of the I/O pins are broken out to the pin headers on both sides for easy interfacing. Developers can connect these pins to peripherals as needed. Standard headers also make development easy and convenient when using a breadboard.

The board supports various ESP32 modules, including [ESP32-WROOM-32](#), [ESP32-WROOM-32U](#), [ESP32-WROOM-32D](#), [ESP32-SOLO-1](#), and [ESP32-WROVER](#) series.

Functional Description

The following list and figure below describe key components, interfaces and controls of ESP32-DevKitC V4 board.

ESP32-WROOM-32

[ESP32-WROOM-32](#) module soldered to the ESP32-DevKitC V4 board.

Optional Space for ESP32-WROVER

Longer [ESP32-WROVER](#) modules may be soldered instead of the ESP32-WROOM-32.

USB-to-UART Bridge

A single chip USB-to-UART bridge provides up to 3 Mbps transfers rates.

Boot Button

Download button: holding down the **Boot** button and pressing the **EN** button initiates the firmware download mode. Then user can download firmware through the serial port.

EN Button

Reset button: pressing this button resets the system.

Micro USB Port

USB interface. It functions as the power supply for the board and the communication interface between PC and the ESP module.

5V Power On LED

This LED lights when the USB or an external 5V power supply is applied to the board. For details see schematic in [Related Documents](#).

I/O Connector

Most of the pins on the ESP module are broken out to the pin headers on the board. Users can program ESP32 to enable multiple functions such as PWM, ADC, DAC, I2C, I2S, SPI, etc.

Note

Some of broken out pins are used internally by the ESP32-WROOM-32, ESP32-WROOM-32D/U and ESP32-SOLO-1 modules to communicate with SPI memory. They are grouped on one side of the board besides the USB connector and labeled CLK, D0, D1, D2, D3 and CMD (GPIO6 - GPIO11). In general these pins should be left unconnected, otherwise access to the SPI flash memory / SPI RAM may be disturbed.

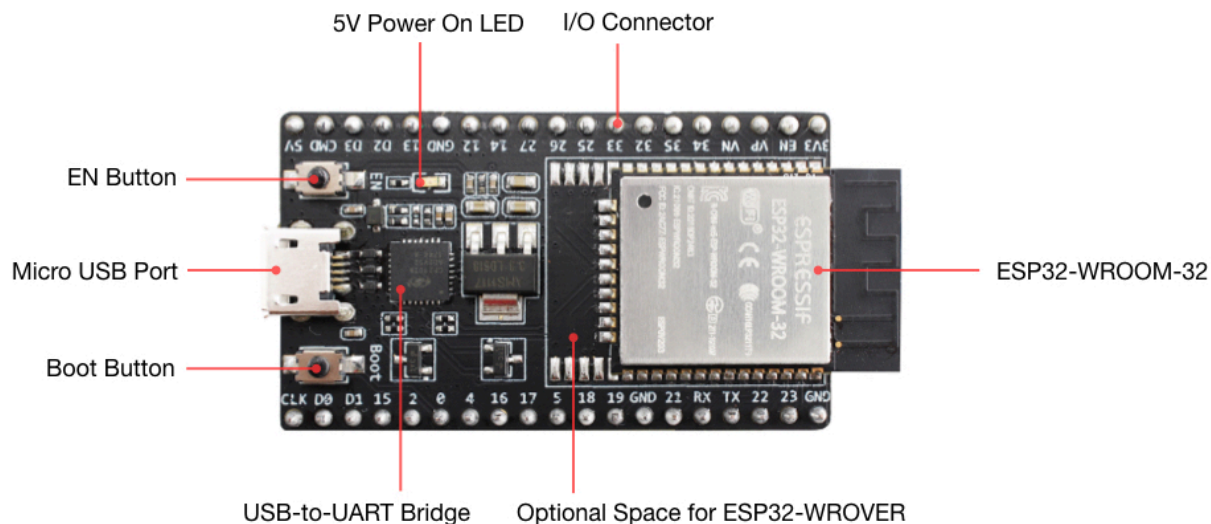

ESP32-DevKitC V4 with ESP32-WROOM-32 module soldered

Power Supply Options

The following options are available to provide power supply to this board:

1. Micro USB port, this is default power supply connection
2. 5V / GND header pins
3. 3V3 / GND header pins

⚠ Warning

Above options are mutually exclusive, i.e. the power supply may be provided using only one of the above options. Attempt to power the board using more than one connection at a time may damage the board and/or the power supply source.

Note on C15

The C15, on the board of earlier batches of V4, may bring two issues:

1. The board may boot into download mode;
2. If users output clock on GPIO0, C15 may impact the clock output.

As a result, if users believe that C15 will impact their use of the board, they can remove it completely (please refer to the screenshot below for the precise location of C15 that is colored in yellow). Otherwise, users do not need to concern about C15.

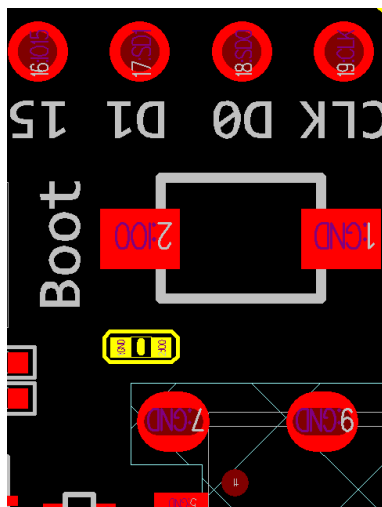

Location of C15 (colored yellow) on ESP32-DevKitC V4 board

Start Application Development

Before powering up the ESP32-DevKitC, please make sure that the board has been received in good condition with no obvious signs of damage.

To start development of applications, proceed to section [Get Started](#), that will walk you through the following steps:

- [Setup Toolchain](#) in your PC to develop applications for ESP32 in C language
- [Connect](#) the module to the PC and verify if it is accessible
- [Build and Flash](#) an example application to the ESP32
- [Monitor](#) instantly what the application is doing

Board Dimensions

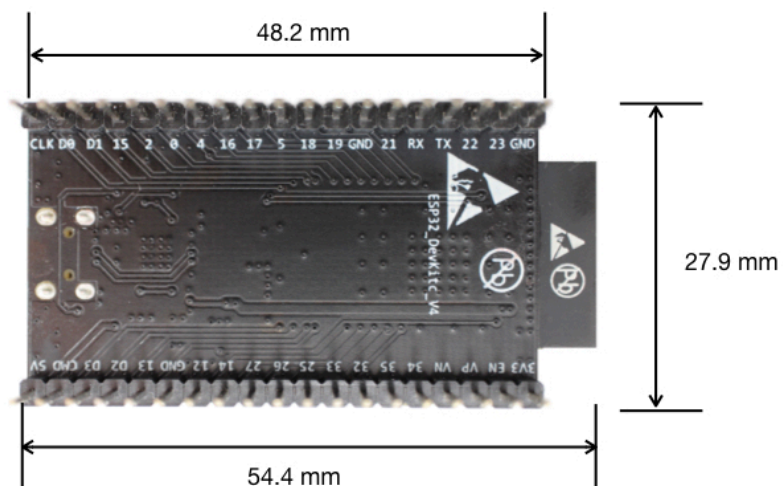

ESP32-DevKitC board dimensions - back

Related Documents

- [ESP32-DevKitC V4 schematic \(PDF\)](#)
- [ESP32 Datasheet \(PDF\)](#)
- [ESP32-WROOM-32 Datasheet \(PDF\)](#)
- [ESP32-WROOM-32D/U Datasheet \(PDF\)](#)

Данный компонент на территории Российской Федерации

Вы можете приобрести в компании MosChip.

Для оперативного оформления запроса Вам необходимо перейти по данной ссылке:

<http://moschip.ru/get-element>

Вы можете разместить у нас заказ для любого Вашего проекта, будь то серийное производство или разработка единичного прибора.

В нашем ассортименте представлены ведущие мировые производители активных и пассивных электронных компонентов.

Нашей специализацией является поставка электронной компонентной базы двойного назначения, продукции таких производителей как XILINX, Intel (ex.ALTERA), Vicor, Microchip, Texas Instruments, Analog Devices, Mini-Circuits, Amphenol, Glenair.

Сотрудничество с глобальными дистрибьюторами электронных компонентов, предоставляет возможность заказывать и получать с международных складов практически любой перечень компонентов в оптимальные для Вас сроки.

На всех этапах разработки и производства наши партнеры могут получить квалифицированную поддержку опытных инженеров.

Система менеджмента качества компании отвечает требованиям в соответствии с ГОСТ Р ИСО 9001, ГОСТ РВ 0015-002 и ЭС РД 009

Офис по работе с юридическими лицами:

105318, г.Москва, ул.Щербаковская д.3, офис 1107, 1118, ДЦ «Щербаковский»

Телефон: +7 495 668-12-70 (многоканальный)

Факс: +7 495 668-12-70 (доб.304)

E-mail: info@moschip.ru

Skype отдела продаж:

moschip.ru

moschip.ru_4

moschip.ru_6

moschip.ru_9