



KMT37

Magnetic Angle Sensor

SPECIFICATIONS

- ✦ AMR Sensor with 180° period
- ✦ For the use at moderate field strengths
- ✦ High accuracy
- ✦ Reliable SO8-package
- ✦ Qualified for automotive applications

The KMT37 is a magnetic field sensor based on the anisotropic magneto resistance effect, i.e. it is sensing the **magnetic field direction** independently on the magnetic field strength for applied field strengths $H \geq 14$ kA/m. The sensor contains two parallel supplied Wheatstone bridges, which enclose a sensitive angle of 45 degrees.

A rotating magnetic field in the surface parallel to the chip (x-y plane) will deliver two independent sinusoidal output signals, one following a $\cos(2\vartheta)$ and the second following a $\sin(2\vartheta)$ function, ϑ being the angle between sensor and field direction (See Figure 2).

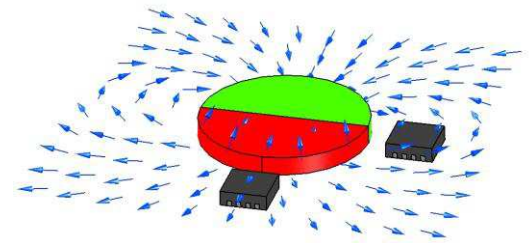
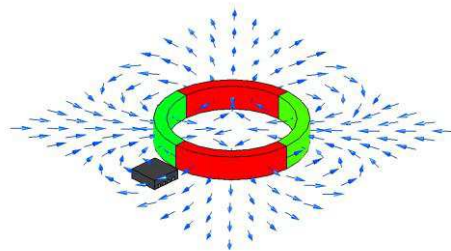
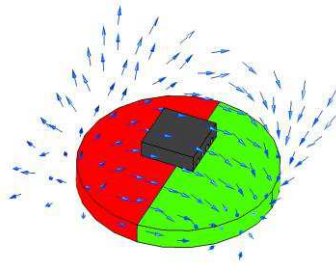

FEATURES

- ✦ Contactless angular position
- ✦ Design optimized linearity
- ✦ High accuracy
- ✦ Low cost, low power
- ✦ Self diagnosis feature
- ✦ User has complete control over signal evaluation
- ✦ Reliable SO8-Package
- ✦ High rotational speed possible
- ✦ Extended operating temperature range
- ✦ (-40 °C to +150 °C)
- ✦ Ideal for harsh environments due to magnetic sensing principle
- ✦ RoHS compliant (lead free)

APPLICATIONS

- ✦ Absolute and incremental angle measurement
- ✦ Motor motion control
- ✦ Robotics
- ✦ Camera positioning
- ✦ Potentiometer replacement
- ✦ Position measurement in medical applications
- ✦ Automotive (steering angle, torque, etc.)

CHARACTERISTIC VALUES

Parameter	Condition	Symbol	Min	Typ	Max	Unit
Absolute maximum ratings						
Supply voltage		V_{CC}			10	V
Operating temperature		T_{OP}	-40		+150	°C
Storage temperature		T_{ST}	-50		+150	°C
Operating conditions						
Supply voltage		V_{CC}	0	5	8.5	V
Applied magnetic field		H	14	25	400	kA/m

General parameters						
Bridge resistance	T = 25 °C	R_B	2.4	3.0	3.6	k_{Ω}
max. signal amplitude	T = 25 °C, H = 25 kA/m	$\Leftrightarrow V/V_{CC}$	9	11	13	mV/V
Offset voltage 2)	T = 25 °C, H = 25 kA/m	V_{OFF}/V_{CC}	-1		+1	mV/V
Hysteresis 1) (Repeatability)	H = 14 kA/m H = 25 kA/m	Hyst		0.1 0.05	0.4 0.1	deg
Accuracy 1)	H = 14 kA/m H = 25 kA/m	$\Leftrightarrow \Rightarrow$		0.1 0.05	0.5 0.15	deg
TC of amplitude	H = 25 kA/m, 3)	TC_{SV}		-0.35		%/K
TC of bridge resistance	3)	TC_{BR}		+0.35		%/K
TC of offset voltage	H = 25 kA/m, 1), 2)	TC_{Voff}	-4	0	+4	$\mu V/V/K$
Amplitude synchronism	H = 25 kA/m, 4)	k	99.5	100	100.5	%
Sensitivity (zero crossing)	H = 25 kA/m, 4), $\Rightarrow 1 = 135^\circ, \Rightarrow 2 = 0^\circ$	$S_{\Rightarrow 1}$ or $S_{\Rightarrow 2}$	$\Leftrightarrow V_n/V_{CC} [mV/V] \times \blacktriangle / 180^\circ$			mV/V/deg
Peak output voltage	H = 25 kA/m, $V_{CC} = 5 V$, 4)	$V_{po\Omega}$	45	55	65	mV/V

- 1) Hysteresis and accuracy are depending nearly inversely proportional on the magnetic field strength. The accuracy is defined as the max. angular difference between actual field angle and measured angle calculated from the third and fifth harmonics of the Fourier spectrum. The hysteresis is defined as angular difference between left and right turn.
- 2) Offset voltages are calculated by measuring both output voltages at several field angles between 0 and 360°, then drawing a diagram with the output voltages as axis and fitting a circle to the signal points. The Offsets are the coordinates of the circle center.
- 3) Reference temperature (Temp. with parameter value = 100%) $T_{ref} = -25^\circ C$, calculated from values at $-25^\circ C$ and $+125^\circ C$.
- 4) This parameter is given for reference only and is not measured on a regular basis.

BLOCK DIAGRAM

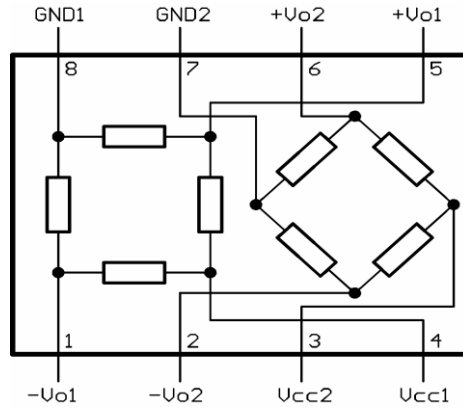

Figure 1: internal and external connections

TYPICAL PERFORMANCE CURVES

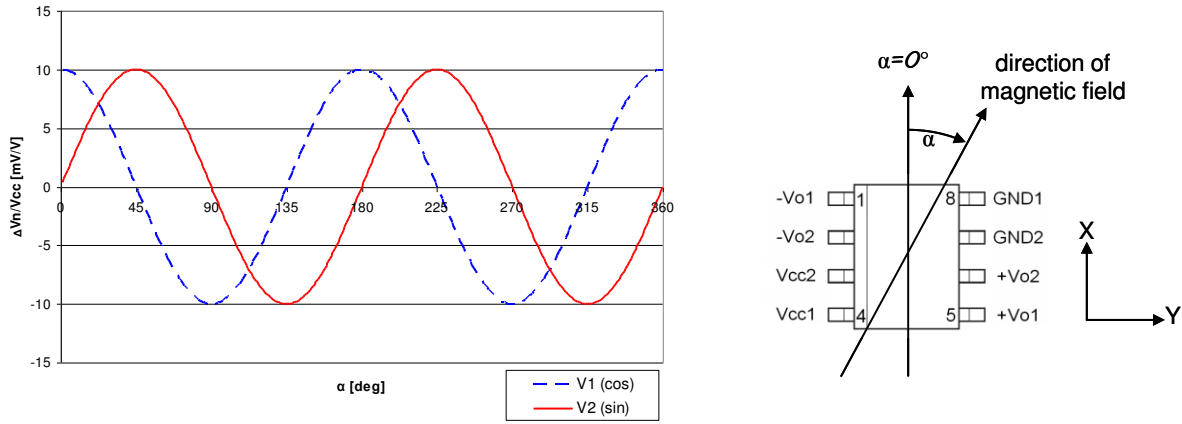
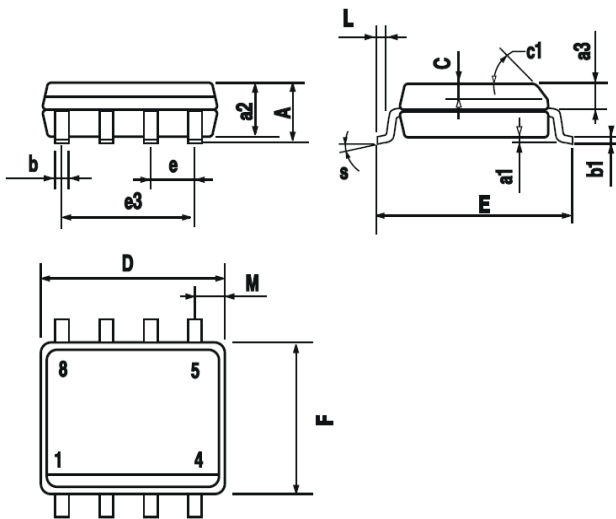

Figure 2: Characteristic curves for KMT37

SENSOR OUTLINE



DIM.	mm			inch		
	MIN.	TYP.	MAX	MIN.	TYP.	MAX
A			1.75			0.069
a1	0.1		0.25	0.004		0.010
a2			1.65			0.065
a3	0.65		0.85	0.026		0.033
b	0.35		0.48	0.014		0.019
b1	0.19		0.25	0.007		0.010
C	0.25		0.5	0.010		0.020
c1	45° (typ.)					
D (1)	4.8		5.0	0.189		0.197
E	5.8		6.2	0.228		0.244
e		1.27			0.050	
e3		3.81			0.150	
F (1)	3.8		4.0	0.150		0.157
L	0.4		1.27	0.016		0.050
M			0.6			0.024
S	8° (max.)					

Figure 3: SO8-Package

PIN ASSIGNMENT

Pin	Symbol	Function
1	-V _{o1}	negative output bridge 1
2	-V _{o2}	negative output bridge 2
3	V _{cc2}	positive supply voltage bridge 2
4	V _{cc1}	positive supply voltage bridge 1
5	+V _{o1}	positive output bridge 1
6	+V _{o2}	positive output bridge 2
7	GND ₂	negative supply voltage bridge 2
8	GND ₁	negative supply voltage bridge 1

SOLDER PROFILE

Recommended solder reflow process according to IPC/JEDEC J-STD-020D (Pb-Free Process)

KMT37

Angular Sensor

ORDERING CODE

DEVICE	DELIVERY FORM	MOQ	PART NUMBER
KMT37	TnR	1 Reel (2500 pcs.)	G-MRCO-037
KMT37	Tube	1 Tube	on request

ORDERING INFORMATION

NORTH AMERICA

Measurement Specialties, Inc.,
a TE Connectivity Company
Phone: +1-800-522-6752
Email: customercare.hmpt@te.com

EUROPE

MEAS Deutschland GmbH (Europe)
a TE Connectivity Company
Phone: +49-800-440-5100
Email: customercare.dtm@te.com

ASIA

Measurement Specialties (China), Ltd.,
a TE Connectivity Company
Phone: +86-400-820-6015
Email: customercare.shzn@te.com

TE.com/sensorsolutions

Measurement Specialties, Inc., a TE Connectivity company.

Measurement Specialties, TE Connectivity, TE Connectivity (logo) and EVERY CONNECTION COUNTS are trademarks. All other logos, products and/or company names referred to herein might be trademarks of their respective owners.

The information given herein, including drawings, illustrations and schematics which are intended for illustration purposes only, is believed to be reliable. However, TE Connectivity makes no warranties as to its accuracy or completeness and disclaims any liability in connection with its use. TE Connectivity's obligations shall only be as set forth in TE Connectivity's Standard Terms and Conditions of Sale for this product and in no case will TE Connectivity be liable for any incidental, indirect or consequential damages arising out of the sale, resale, use or misuse of the product. Users of TE Connectivity products should make their own evaluation to determine the suitability of each such product for the specific application.

© 2015 TE Connectivity Ltd. family of companies All Rights Reserved.

Данный компонент на территории Российской Федерации

Вы можете приобрести в компании MosChip.

Для оперативного оформления запроса Вам необходимо перейти по данной ссылке:

<http://moschip.ru/get-element>

Вы можете разместить у нас заказ для любого Вашего проекта, будь то серийное производство или разработка единичного прибора.

В нашем ассортименте представлены ведущие мировые производители активных и пассивных электронных компонентов.

Нашей специализацией является поставка электронной компонентной базы двойного назначения, продукции таких производителей как XILINX, Intel (ex.ALTERA), Vicor, Microchip, Texas Instruments, Analog Devices, Mini-Circuits, Amphenol, Glenair.

Сотрудничество с глобальными дистрибьюторами электронных компонентов, предоставляет возможность заказывать и получать с международных складов практически любой перечень компонентов в оптимальные для Вас сроки.

На всех этапах разработки и производства наши партнеры могут получить квалифицированную поддержку опытных инженеров.

Система менеджмента качества компании отвечает требованиям в соответствии с ГОСТ Р ИСО 9001, ГОСТ РВ 0015-002 и ЭС РД 009

Офис по работе с юридическими лицами:

105318, г.Москва, ул.Щербаковская д.3, офис 1107, 1118, ДЦ «Щербаковский»

Телефон: +7 495 668-12-70 (многоканальный)

Факс: +7 495 668-12-70 (доб.304)

E-mail: info@moschip.ru

Skype отдела продаж:

moschip.ru

moschip.ru_4

moschip.ru_6

moschip.ru_9