

12 mm Square Two-in-One Rotary Potentiometers (Dual Type)

Japan
Malaysia

Type: **EVJC/EVJY**



■ Features

- Rectangular-shaped, automatic mounting type
- High tactile feedback
- Available for automatic dip soldering (Flux-proof structure)
- Highly reliable and dust-proof

■ Recommended Applications

- Audio Equipment
- Video Equipment
- Electronic Musical Instruments

■ Explanation of Part Numbers



■ Product Chart

Installation direction	Style	Height (H=mm)	Applications	Detent	Type
Horizontal	Without bushing	10.0	Volume control	Without detent	EVJC00
			Tone control	Without detent	EVJC30
				Midpoint	EVJC31
		12.5	Volume control	Without detent	EVJC90
			Tone control	Without detent	EVJC40
				Midpoint	EVJC41
	With bushing	10.0	Volume control	Without detent	EVJC20
			Tone control	Without detent	EVJC50
				Midpoint	EVJC51
		12.5	Volume control	Without detent	EVJCB0
			Tone control	Without detent	EVJCH0
				Midpoint	EVJCH1
With sleeve	10.0	Volume control	Without detent	EVJC25	
		Tone control	Without detent	EVJC55	
			Midpoint	EVJC56	
	12.5	Volume control	Without detent	EVJCB5	
		Tone control	Without detent	EVJCH5	
			Midpoint	EVJCH6	
Vertical	Without bushing	—	Volume control	Without detent	EVJY00
			Tone control	Without detent	EVJY80
				Midpoint	EVJY81
	With bushing	—	Volume control	Without detent	EVJY10
			Tone control	Without detent	EVJY90
				Midpoint	EVJY91
	With sleeve	—	Volume control	Without detent	EVJY15
			Tone control	Without detent	EVJY95
				Midpoint	EVJY96

■ Specifications

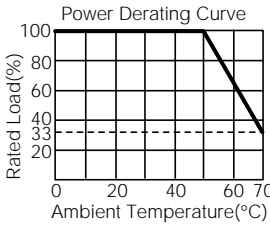
Classification	Item																																													
Applications	12 mm square Two-in-One																																													
Mechanical Specifications	Rotation Angle	300 °																																												
	Rotation Torque	2 mN·m to 20 mN·m																																												
	Shaft Stopper Strength	0.5 N·m min.																																												
	Shaft Pull/Push Strength	80 N min.																																												
	Shaft Inclination (Measured at the top of the shaft)	0.35 mm max.																																												
	Bushing-Nut Tightening Torque	1 N·m max.																																												
Electrical Specifications	Nominal Total Resistance	5 kΩ to 500 kΩ (Tolerance ±20 %)																																												
	Taper	A, B, C, D, G, BH																																												
	Power Rating	<p>0.05 W (0 °C to 50 °C) For potentiometers operating in ambient temperatures above 50 °C, Rating should be derated in accordance with the figure on the right.</p> 																																												
	Residual Resistance	<table border="1"> <thead> <tr> <th rowspan="2">Type Taper & Terminal</th> <th colspan="4">For general purpose (tone)</th> <th colspan="4">For volume control</th> </tr> <tr> <th>A, B, D, G 1 to 2</th> <th>B, C, G 2 to 3</th> <th>A, D 2 to 3</th> <th>C 1 to 2</th> <th>A, B, D 1 to 2</th> <th>A, B, D 2 to 3</th> <th>C 1 to 2</th> <th>C 2 to 3</th> </tr> </thead> <tbody> <tr> <td>Nominal Total Resistance</td> <td>5 kΩ < R < 50 kΩ</td> <td>25 Ω max.</td> <td>25 Ω max.</td> <td>25 Ω max.</td> <td>15 Ω max.</td> <td>25 Ω max.</td> <td>20 Ω max.</td> <td>20 Ω max.</td> </tr> <tr> <td></td> <td>50 kΩ < R < 250 kΩ</td> <td>25 Ω max.</td> <td>50 Ω max.</td> <td>50 Ω max.</td> <td>15 Ω max.</td> <td>50 Ω max.</td> <td>20 Ω max.</td> <td>20 Ω max.</td> </tr> <tr> <td></td> <td>250 kΩ < R < 500 kΩ</td> <td>100 Ω max.</td> <td>100 Ω max.</td> <td>100 Ω max.</td> <td>50 Ω max.</td> <td>100 Ω max.</td> <td>50 Ω max.</td> <td>50 Ω max.</td> </tr> </tbody> </table>	Type Taper & Terminal	For general purpose (tone)				For volume control				A, B, D, G 1 to 2	B, C, G 2 to 3	A, D 2 to 3	C 1 to 2	A, B, D 1 to 2	A, B, D 2 to 3	C 1 to 2	C 2 to 3	Nominal Total Resistance	5 kΩ < R < 50 kΩ	25 Ω max.	25 Ω max.	25 Ω max.	15 Ω max.	25 Ω max.	20 Ω max.	20 Ω max.		50 kΩ < R < 250 kΩ	25 Ω max.	50 Ω max.	50 Ω max.	15 Ω max.	50 Ω max.	20 Ω max.	20 Ω max.		250 kΩ < R < 500 kΩ	100 Ω max.	100 Ω max.	100 Ω max.	50 Ω max.	100 Ω max.	50 Ω max.	50 Ω max.
	Type Taper & Terminal	For general purpose (tone)				For volume control																																								
		A, B, D, G 1 to 2	B, C, G 2 to 3	A, D 2 to 3	C 1 to 2	A, B, D 1 to 2	A, B, D 2 to 3	C 1 to 2	C 2 to 3																																					
	Nominal Total Resistance	5 kΩ < R < 50 kΩ	25 Ω max.	25 Ω max.	25 Ω max.	15 Ω max.	25 Ω max.	20 Ω max.	20 Ω max.																																					
		50 kΩ < R < 250 kΩ	25 Ω max.	50 Ω max.	50 Ω max.	15 Ω max.	50 Ω max.	20 Ω max.	20 Ω max.																																					
		250 kΩ < R < 500 kΩ	100 Ω max.	100 Ω max.	100 Ω max.	50 Ω max.	100 Ω max.	50 Ω max.	50 Ω max.																																					
	Maximum Attenuation (for volume control, taper A, B, D)	<table border="1"> <thead> <tr> <th>Nominal total resistance</th> <th>Max. Attenuation</th> <th rowspan="4">Insertion loss 0.1 dB max.</th> </tr> </thead> <tbody> <tr> <td>5 kΩ < R < 10 kΩ</td> <td>-65 dB max.</td> </tr> <tr> <td>10 kΩ < R < 50 kΩ</td> <td>-72 dB max.</td> </tr> <tr> <td>50 kΩ < R < 100 kΩ</td> <td>-82 dB max.</td> </tr> <tr> <td>100 kΩ < R</td> <td>-92 dB max.</td> <td></td> </tr> </tbody> </table>	Nominal total resistance	Max. Attenuation	Insertion loss 0.1 dB max.	5 kΩ < R < 10 kΩ	-65 dB max.	10 kΩ < R < 50 kΩ	-72 dB max.	50 kΩ < R < 100 kΩ	-82 dB max.	100 kΩ < R	-92 dB max.																																	
Nominal total resistance	Max. Attenuation	Insertion loss 0.1 dB max.																																												
5 kΩ < R < 10 kΩ	-65 dB max.																																													
10 kΩ < R < 50 kΩ	-72 dB max.																																													
50 kΩ < R < 100 kΩ	-82 dB max.																																													
100 kΩ < R	-92 dB max.																																													
Tracking	For volume control within ±3 dB at -40 to 0 dB For Tone control within ±3 dB at midpoint																																													
Insulation Resistance	100 MΩ min. at 250 Vdc																																													
Dielectric Withstand Voltage	300 Vac for 1 minute																																													
Noise Level	47 mV max. Apply 20 V (When Voltage Rating < 20 V, use the rated voltage.) Rotate shaft at 30 r/min.																																													
Endurance	Operating Life *1	15000 cycles min.																																												
Minimum Quantity/Packing Unit *2	80 pcs. (Tray Pack)	L ≤ 20.0 mm																																												
	60 pcs. (Tray Pack)	L > 20.0 mm																																												
Packing Unit *2	800 pcs.	L ≤ 20.0 mm																																												
	600 pcs.	L > 20.0 mm																																												

*1 : No direct current should be applied.

*2 : With bushing : L=L+7.5 mm

Design and specifications are each subject to change without notice. Ask factory for the current technical specifications before purchase and/or use. Should a safety concern arise regarding this product, please be sure to contact us immediately.

■ Dimensions in mm (not to scale)

for Volume : EVJC00, EVJC90
 for Tone : EVJC30, EVJC40 (without detent)
 EVJC31, EVJC41 (with detent)

● Horizontal, without Bushing

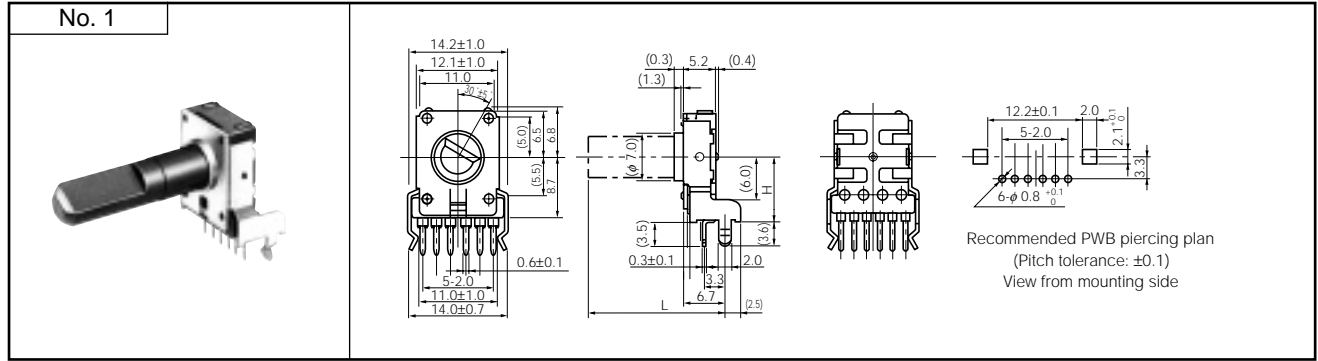

for Volume : EVJC20, EVJCB0
 for Tone : EVJC50, EVJCH0 (without detent)
 EVJC51, EVJCH1 (with detent)

● Horizontal, with Bushing

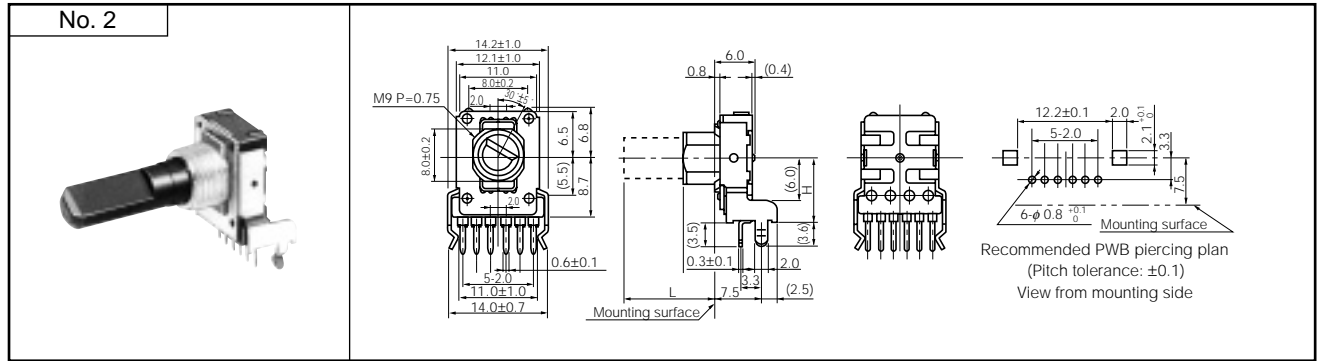

for Volume : EVJC25, EVJCB5
 for Tone : EVJC55, EVJCH5 (without detent)
 EVJC56, EVJCH6 (with detent)

● Horizontal, with Sleeve

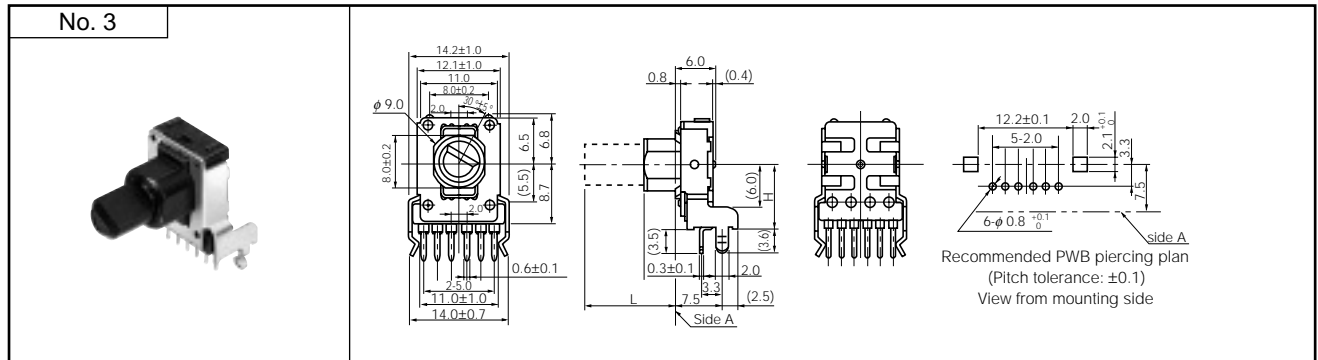

for Volume : EVJY00
 for Tone : EVJY80 (without detent)
 EVJY81 (with detent)

● Vertical, without Bushing

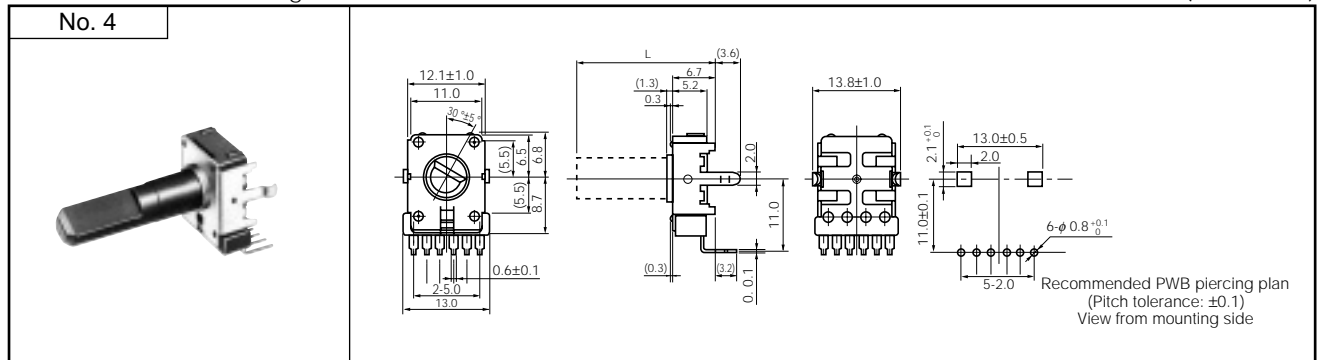

for Volume : EVJY10
 for Tone : EVJY90 (without detent)
 EVJY91 (with detent)

● Vertical, with Bushing



for Volume : EVJY15
 for Tone : EVJY95 (without detent)
 EVJY96 (with detent)

● Vertical, with Sleeve



■ Circuit Diagram and PWB Piercing Plan

	Volume control without tap	With tap	Tone control
Relation of mounting holes and terminals			

Notes:

1. I=Resistor 1, II=Resistor 2
2. Relation of mounting holes and terminals. Refer to each piercing plan for dimensions.
3. View from mounted part side.

■ Shaft Trims and Dimensions in mm

Dimensions	Trim Position

Note: The drawing at full CCW position

Style			Dimensions in mm			
			Shaft			Bushing, Sleeve
			L	ℓ ₁	Corner cut	ℓ ₂
without Bushing	Horizontal		15.0	4.5	C0.5	—
			20.0	7.0	C1.0	—
			25.0	12.0	C1.0	—
			30.0	12.0	C1.0	—
	Vertical		15.0	4.5	C0.5	—
			20.0	7.0	C1.0	—
			25.0	12.0	C1.0	—
			30.0	12.0	C1.0	—
with Bushing or with Sleeve	Horizontal		12.5	7.0	C1.0	5.0
			15.0	7.0	C1.0	5.0
			17.5	12.0	C1.0	5.0
			20.0	12.0	C1.0	5.0, 7.0
			22.5	12.0	C1.0	5.0, 7.0
	Vertical		12.5	7.0	C1.0	5.0
			15.0	7.0	C1.0	5.0
			17.5	12.0	C1.0	5.0
			20.0	12.0	C1.0	5.0, 7.0
			22.5	12.0	C1.0	5.0, 7.0

Design and specifications are each subject to change without notice. Ask factory for the current technical specifications before purchase and/or use. Should a safety concern arise regarding this product, please be sure to contact us immediately.

Данный компонент на территории Российской Федерации

Вы можете приобрести в компании MosChip.

Для оперативного оформления запроса Вам необходимо перейти по данной ссылке:

<http://moschip.ru/get-element>

Вы можете разместить у нас заказ для любого Вашего проекта, будь то серийное производство или разработка единичного прибора.

В нашем ассортименте представлены ведущие мировые производители активных и пассивных электронных компонентов.

Нашей специализацией является поставка электронной компонентной базы двойного назначения, продукции таких производителей как XILINX, Intel (ex.ALTERA), Vicor, Microchip, Texas Instruments, Analog Devices, Mini-Circuits, Amphenol, Glenair.

Сотрудничество с глобальными дистрибьюторами электронных компонентов, предоставляет возможность заказывать и получать с международных складов практически любой перечень компонентов в оптимальные для Вас сроки.

На всех этапах разработки и производства наши партнеры могут получить квалифицированную поддержку опытных инженеров.

Система менеджмента качества компании отвечает требованиям в соответствии с ГОСТ Р ИСО 9001, ГОСТ РВ 0015-002 и ЭС РД 009

Офис по работе с юридическими лицами:

105318, г.Москва, ул.Щербаковская д.3, офис 1107, 1118, ДЦ «Щербаковский»

Телефон: +7 495 668-12-70 (многоканальный)

Факс: +7 495 668-12-70 (доб.304)

E-mail: info@moschip.ru

Skype отдела продаж:

moschip.ru

moschip.ru_4

moschip.ru_6

moschip.ru_9