

BGC100GN6

Switchable Wideband Directional Coupler IC

Features

- Fully integrated coupler in RF CMOS
- Bi-directional coupler
- Fitted for feedback receivers to accomplish closed loop power control and antenna tuning
- Wide frequency range: 0.6 to 2.7 GHz
- Designed for low insertion loss and high directivity
- Supports all cellular standards: GSM /WCDMA / HSPA+ / FDD-LTE / TD-LTE / TD-SCDMA / CDMA
- Integrated low-pass filter for 5GHz WiFi jammers suppression
- GPIO controlled
- Small form factor 1.1mm x 0.7mm
- RoHS and WEEE compliant package
- Product validation: Qualified for industrial applications according to the relevant tests of JEDEC47/20/22

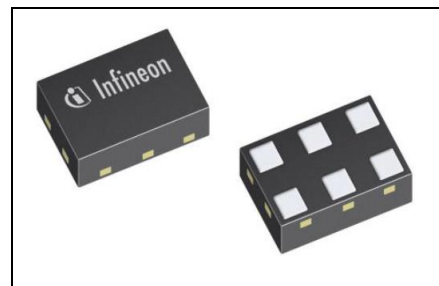

Description

The BGC100GN6 bi-directional coupler IC is designed for 2G/3G/4G RF front end applications. The device contains a bidirectional coupler operating in one or multiple bands within 0.6 to 2.7 GHz frequency range. The coupled output contains a low-pass filter for 5 GHz ISM blockers suppression. The coupler offers low insertion loss and high directivity.

The coupler is controlled via a GPIO pin. No external power supply blocking or RF decoupling capacitors are required. The BGC100GN6 is a fully integrated device deploying Infineon high volume RF-CMOS technology. The device has a very small size of only 1.1 x 0.7mm² and a maximum height of 0.4 mm.

Block diagram and ordering information

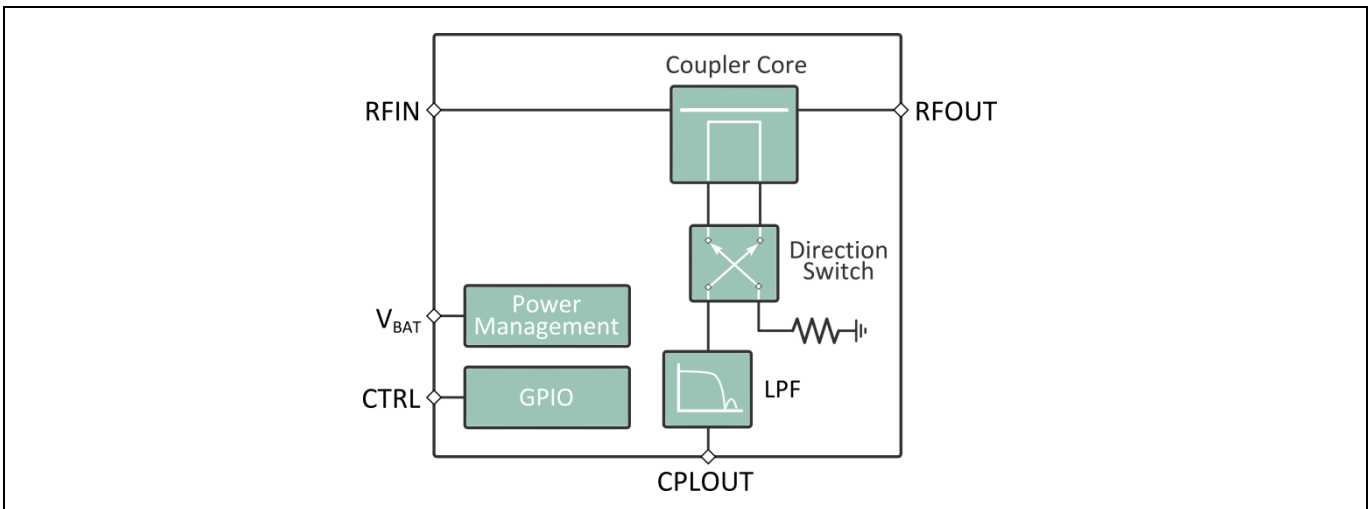

Figure 1 BGC100GN6 Block diagram

Table 1 Ordering Information

Type	Package	Marking
BGC100GN6	TSNP-6-2	2



WEEE Compliant
Package



Halogen-Free
PB Free



RoHS

Trademarks

All referenced product or service names and trademarks are the property of their respective owners.

Edition 2018-01-03

Published by

Infineon Technologies AG

81726 München, Germany

© 2018 Infineon Technologies AG.

All Rights Reserved.

Do you have a question about this document?

Email: erratum@infineon.com

Document reference

ifx1

IMPORTANT NOTICE

The information given in this document shall in no event be regarded as a guarantee of conditions or characteristics ("Beschaffenheitsgarantie").

With respect to any examples, hints or any typical values stated herein and/or any information regarding the application of the product, Infineon Technologies hereby disclaims any and all warranties and liabilities of any kind, including without limitation warranties of non-infringement of intellectual property rights of any third party.

In addition, any information given in this document is subject to customer's compliance with its obligations stated in this document and any applicable legal requirements, norms and standards concerning customer's products and any use of the product of Infineon Technologies in customer's applications.

The data contained in this document is exclusively intended for technically trained staff. It is the responsibility of customer's technical departments to evaluate the suitability of the product for the intended application and the completeness of the product information given in this document with respect to such application.

For further information on the product, technology, delivery terms and conditions and prices please contact your nearest Infineon Technologies office (www.infineon.com).

WARNINGS

Due to technical requirements products may contain dangerous substances. For information on the types in question please contact your nearest Infineon Technologies office.

Except as otherwise explicitly approved by Infineon Technologies in a written document signed by authorized representatives of Infineon Technologies, Infineon Technologies' products may not be used in any applications where a failure of the product or any consequences of the use thereof can reasonably be expected to result in personal injury.

Данный компонент на территории Российской Федерации

Вы можете приобрести в компании MosChip.

Для оперативного оформления запроса Вам необходимо перейти по данной ссылке:

<http://moschip.ru/get-element>

Вы можете разместить у нас заказ для любого Вашего проекта, будь то серийное производство или разработка единичного прибора.

В нашем ассортименте представлены ведущие мировые производители активных и пассивных электронных компонентов.

Нашей специализацией является поставка электронной компонентной базы двойного назначения, продукции таких производителей как XILINX, Intel (ex.ALTERA), Vicor, Microchip, Texas Instruments, Analog Devices, Mini-Circuits, Amphenol, Glenair.

Сотрудничество с глобальными дистрибьюторами электронных компонентов, предоставляет возможность заказывать и получать с международных складов практически любой перечень компонентов в оптимальные для Вас сроки.

На всех этапах разработки и производства наши партнеры могут получить квалифицированную поддержку опытных инженеров.

Система менеджмента качества компании отвечает требованиям в соответствии с ГОСТ Р ИСО 9001, ГОСТ РВ 0015-002 и ЭС РД 009

Офис по работе с юридическими лицами:

105318, г.Москва, ул.Щербаковская д.3, офис 1107, 1118, ДЦ «Щербаковский»

Телефон: +7 495 668-12-70 (многоканальный)

Факс: +7 495 668-12-70 (доб.304)

E-mail: info@moschip.ru

Skype отдела продаж:

moschip.ru

moschip.ru_4

moschip.ru_6

moschip.ru_9