

REVISIONS				
REV.	ECN/E-R	DESCRIPTION	DATE	APPROVED
B		CUSTOMER DRAWING	2006/04/05	J.SI
C		UPDATED	2006/08/09	
D		UPDATED	2007/01/02	

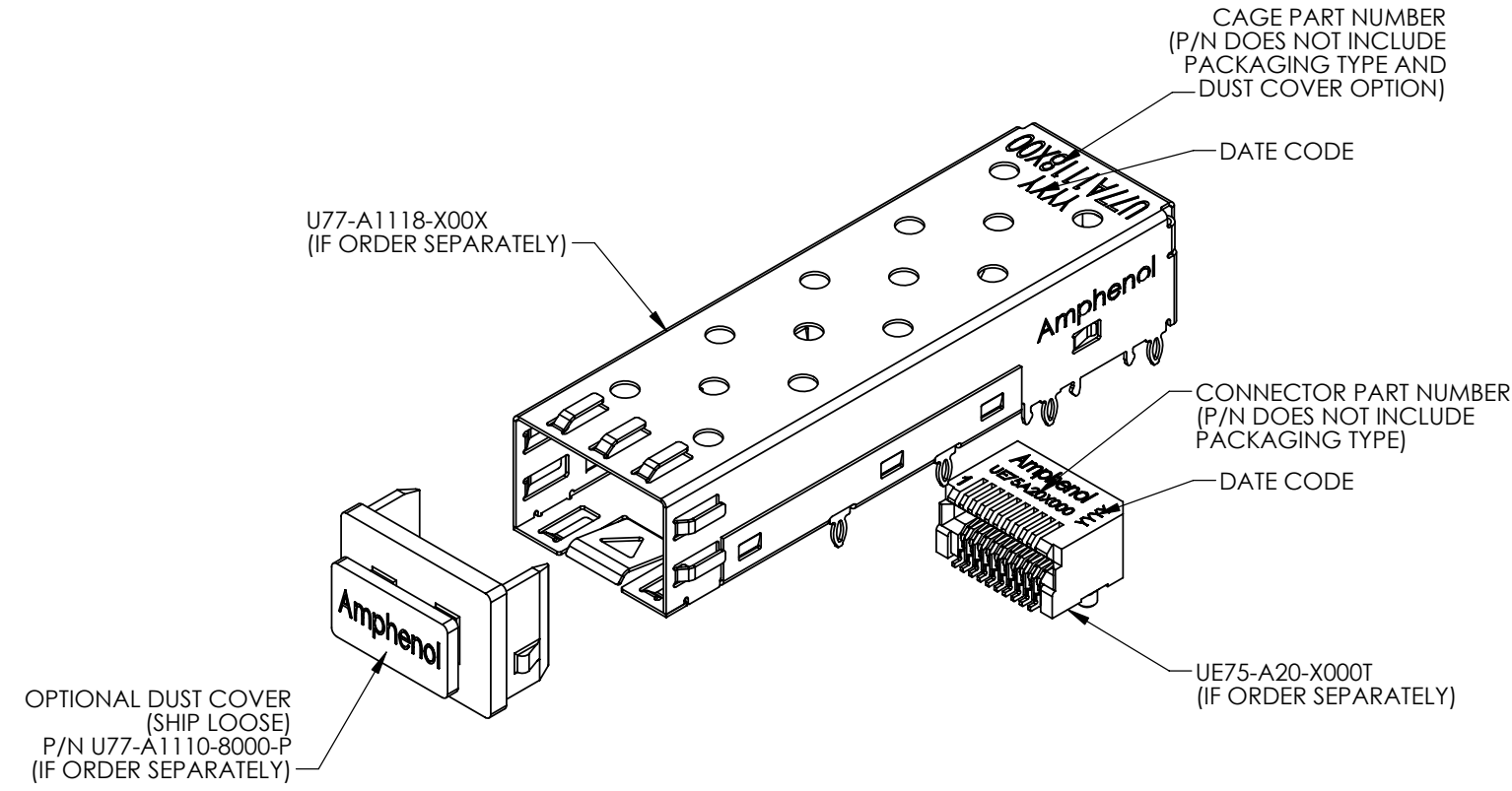

AMPHENOL PART NUMBER CONFIGURATION:

UE78 - A 1 1 1 8 - 0 X X X X

OPTIONAL DUST COVER
 0 - WITHOUT DUST COVER
 D - WITH DUST COVER (SHIP LOOSE)

PLATING OPTIONS FOR CONNECTOR
 2 - 30µ" GOLD PLATING ON MATING AREA
 GOLD FLASH ON TERMINATION
 3 - 30µ" GOLD PLATING ON MATING AREA
 150-300µ" MATTE TIN ON TERMINATION
 5 - 15µ" GOLD PLATING ON MATING AREA
 GOLD FLASH ON TERMINATION
 6 - 15µ" GOLD PLATING ON MATING AREA
 150-300µ" MATTE TIN ON TERMINATION

PACKAGING OPTIONS
 T - TAPE AND REEL PACKAGING
 FOR BOTH CONNECTORS AND
 CAGES
 H - TAPE AND REEL FOR
 CONNECTORS TRAY FOR
 CAGES

PLATING OPTIONS FOR CAGE
 1 - TIN
 2 - NICKEL

MATERIAL (RoHS COMPLIANCE):

CAGE:
 COPPER ALLOY
 PLATING OPTION 1: 100µ" [2.54 µm] TIN PLATING OVER
 50 µ" (1.27 µm) NICKEL UNDER PLATING.
 PLATING OPTION 2: 100µ" [2.54 µm] NICKEL PLATING
 (NOT FOR SOLDER PINS).
DUST COVER
 THERMOPLASTIC, COLOR BLACK.
PACKAGING:
 TAPE AND REEL OR TRAY PACKAGING.
 TEMPERATURE RANGE: -40 °C TO +85 °C

CONNECTOR:

PLASTIC HOUSING:
 HIGH TEMPERATURE RESISTANT NYLON FLAMMABILITY RATING UL94V-0.
CONTACTS:
 PHOSPHOR BRONZE
 PLATING OPTION 2: 30µ" [0.76 µm] GOLD ON MATING AREA AND 2 µ"
 (0.05 µm) GOLD FLASH PLATING ON TERMINATION OVER
 50µ"[1.27µm] NICKEL UNDER LAYER.
 PLATING OPTION 3: 30µ" [0.76 µm] GOLD ON MATING AREA AND
 150-300 µ" (3.81-7.62 µm) LOW WHISKER MATTE TIN PLATING
 ON TERMINATION OVER 50µ" [1.27 µm] NICKEL UNDER LAYER.
 PLATING OPTION 5: 15µ" GOLD PLATING ON MATING AREA
 GOLD FLASH ON TERMINATION
 PLATING OPTION 6: 15µ" GOLD PLATING ON MATING AREA
 150-300µ" (3.81-7.62 µm) MATTE TIN ON TERMINATION

PACKAGING:
 TAPE AND REEL.
 TEMPERATURE RANGE: -40 °C TO +85 °C

DO NOT SCALE DRAWING

THIS DOCUMENT CONTAINS PROPRIETARY INFORMATION AND SUCH INFORMATION MAY NOT BE DISCLOSED TO OTHERS FOR ANY PURPOSE OR USED FOR MANUFACTURING PUPOSES WITHOUT PERMISSION FROM AMPHENOL CANADA CORP.

APPROVALS		DATE	Amphenol Canada Corp.		
DRAWN	A.LIU	2006/02/13			
DESIGNED	J.SI	2006/02/13	TITLE SFP CAGE + CONNECTOR 1X1 8 PRESS FIT / 12 EMI PINS		
CHECKED	J.SI	2006/02/13			
QA APPD	X	X			
IE APPD	X	X	SIZE A3	DWG. NO. P-UE78-A1118-0XXXX	REV. D
DWG APPD			SCALE 2:1	PROJECT	SHEET 1 OF 7

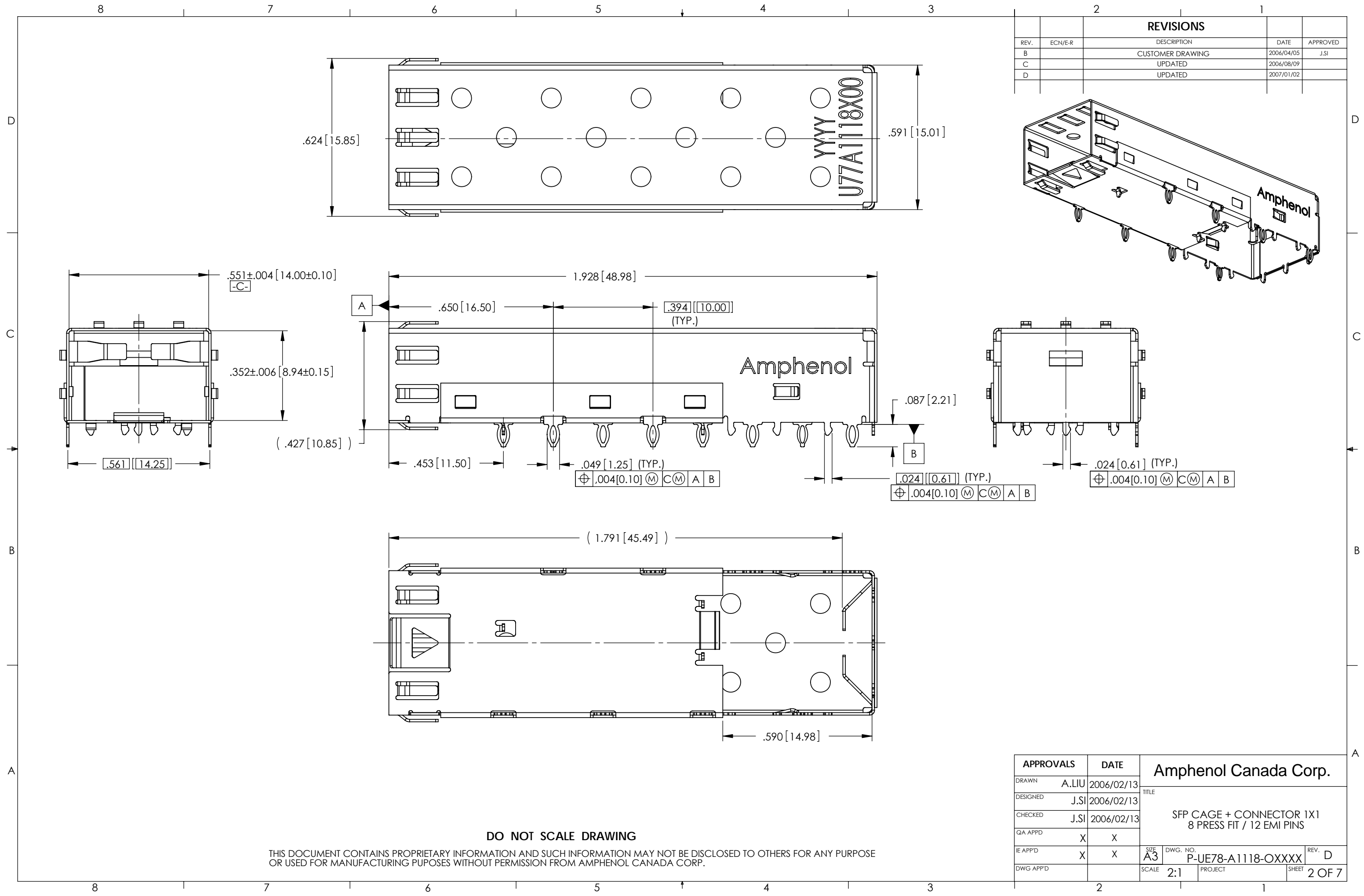

REVISIONS				
REV.	ECN/E-R	DESCRIPTION	DATE	APPROVED
B		CUSTOMER DRAWING	2006/04/05	J.SI
C		UPDATED	2006/08/09	
D		UPDATED	2007/01/02	

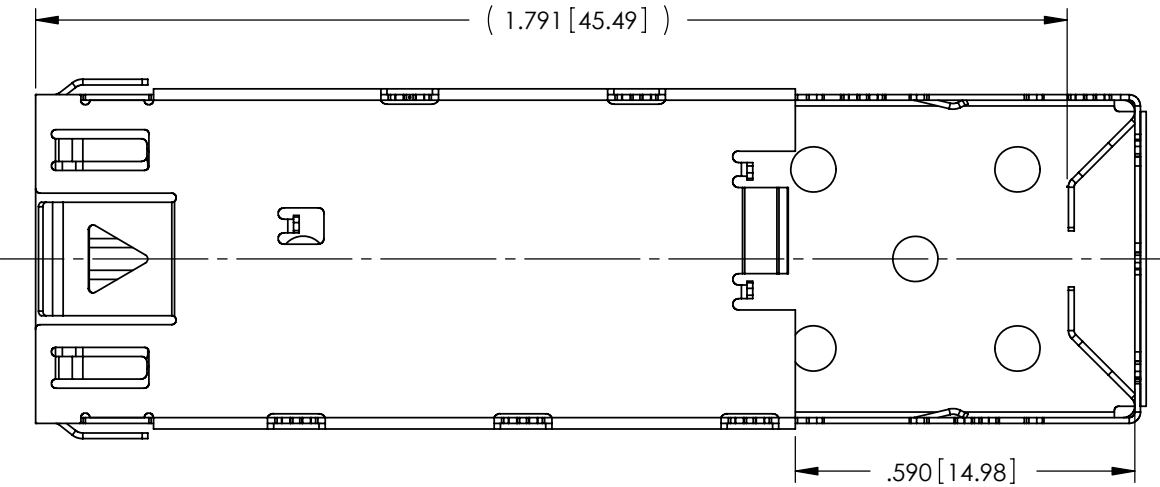
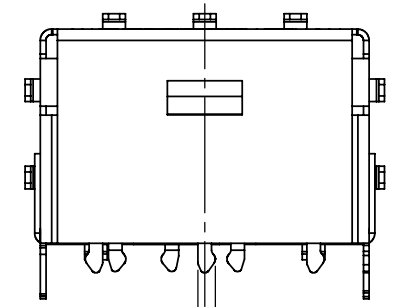
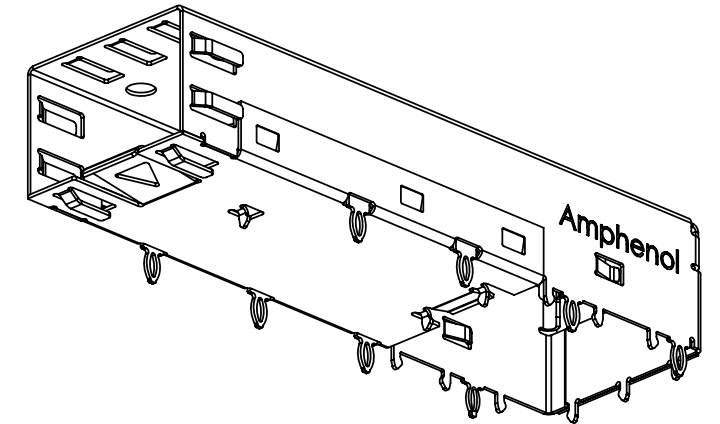

DO NOT SCALE DRAWING

THIS DOCUMENT CONTAINS PROPRIETARY INFORMATION AND SUCH INFORMATION MAY NOT BE DISCLOSED TO OTHERS FOR ANY PURPOSE OR USED FOR MANUFACTURING PUPOSES WITHOUT PERMISSION FROM AMPHENOL CANADA CORP.

APPROVALS		DATE	Amphenol Canada Corp.		
DRAWN	A.LIU	2006/02/13	TITLE		
DESIGNED	J.SI	2006/02/13	SFP CAGE + CONNECTOR 1X1 8 PRESS FIT / 12 EMI PINS		
CHECKED	J.SI	2006/02/13	REV. D		
QA APPD	X	X	SIZE	DWG. NO.	REV.
IE APPD	X	X	A3	P-UE78-A1118-OXXXX	D
DWG APPD			SCALE	PROJECT	SHEET
			2:1		2 OF 7

REVISIONS				
REV.	ECN/E-R	DESCRIPTION	DATE	APPROVED
B		CUSTOMER DRAWING	2006/04/05	J.SI
C		UPDATED	2006/08/09	
D		UPDATED	2007/01/02	

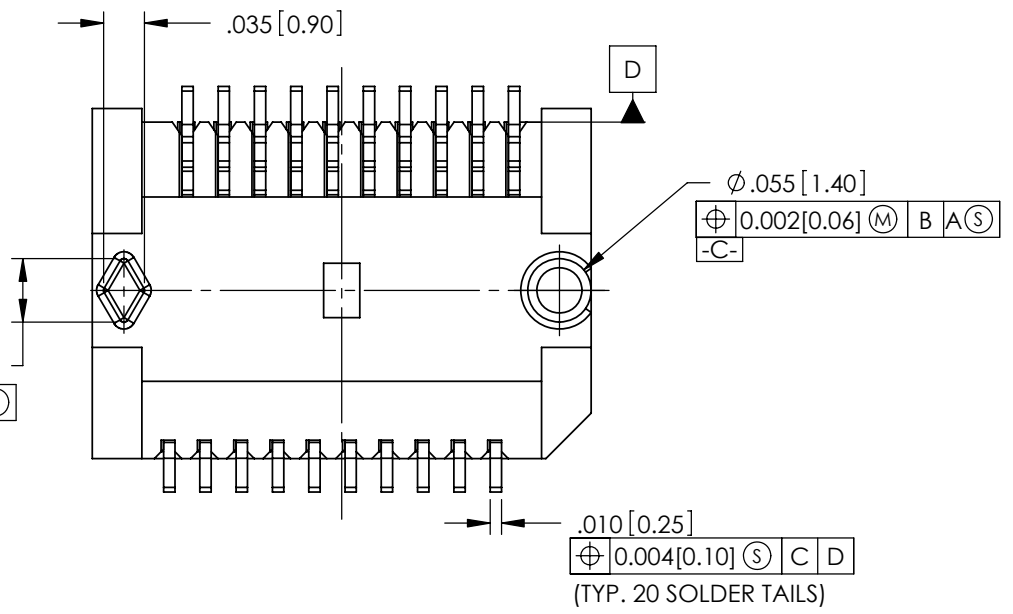
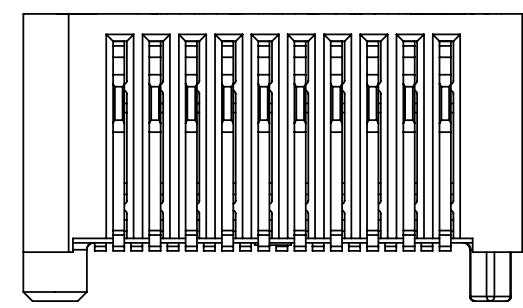
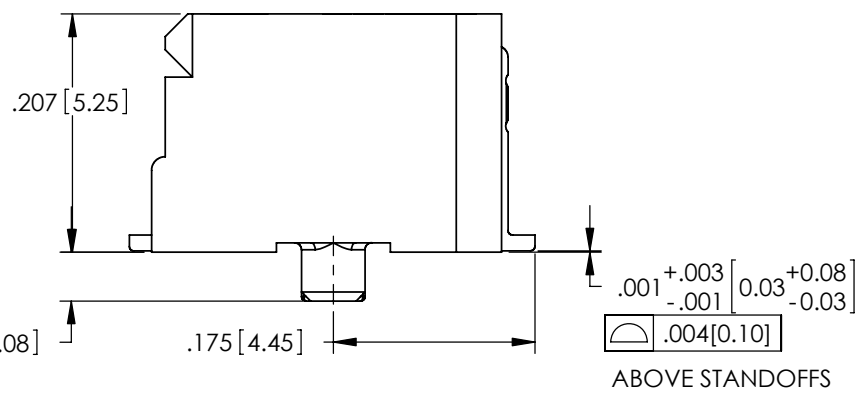
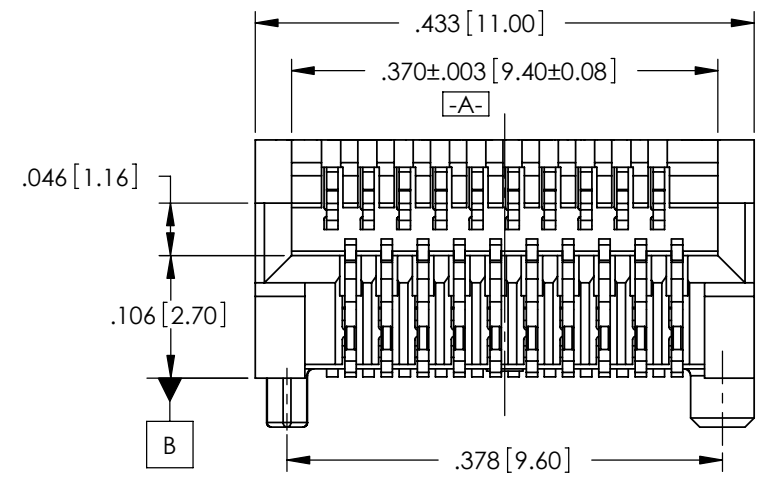
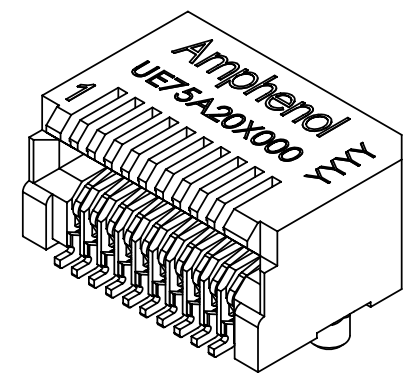
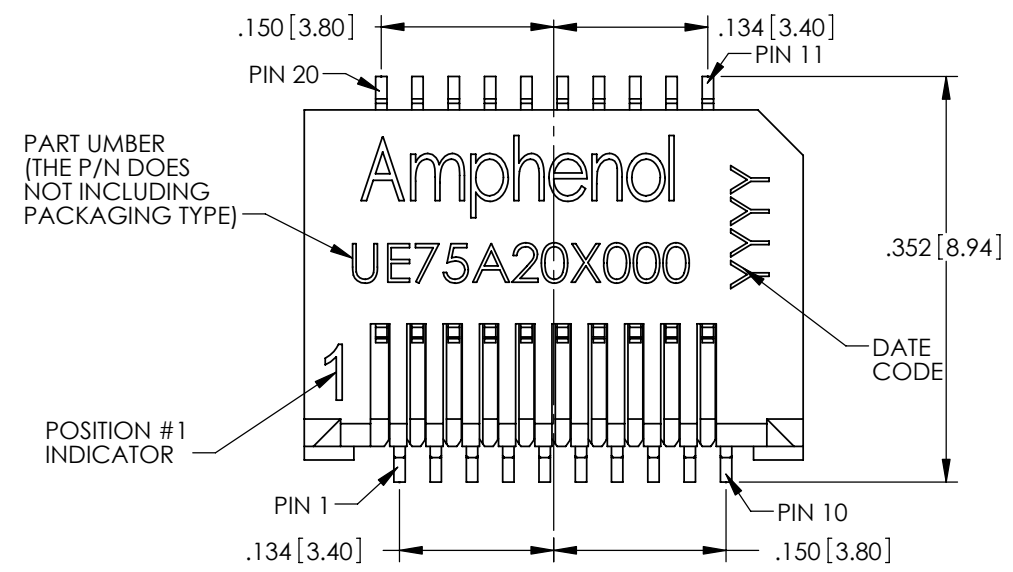

⊕ 0.002 [0.06] (M) B A (S) C (S)

⊕ 0.055 [1.40]
⊕ 0.002 [0.06] (M) B A (S)
-C-

⊕ 0.010 [0.25]
⊕ 0.004 [0.10] (S) C D
(TYP. 20 SOLDER TAILS)

DO NOT SCALE DRAWING

THIS DOCUMENT CONTAINS PROPRIETARY INFORMATION AND SUCH INFORMATION MAY NOT BE DISCLOSED TO OTHERS FOR ANY PURPOSE OR USED FOR MANUFACTURING PURPOSES WITHOUT PERMISSION FROM AMPHENOL CANADA CORP.

APPROVALS		DATE	Amphenol Canada Corp.		
DRAWN	A.LIU	2006/02/13	TITLE		
DESIGNED	J.SI	2006/02/13	SFP CAGE + CONNECTOR 1X1 8 PRESS FIT / 12 EMI PINS		
CHECKED	J.SI	2006/02/13			
QA APPD	X	X			
IE APPD	X	X	SIZE A3	DWG. NO. P-UE78-A1118-0XXXX	REV. D
DWG APPD			SCALE 4:1	PROJECT	SHEET 3 OF 7

REVISIONS				
REV.	ECN/E-R	DESCRIPTION	DATE	APPROVED
B		CUSTOMER DRAWING	2006/04/05	
C		UPDATED	2006/08/09	
D		UPDATED	2007/01/02	

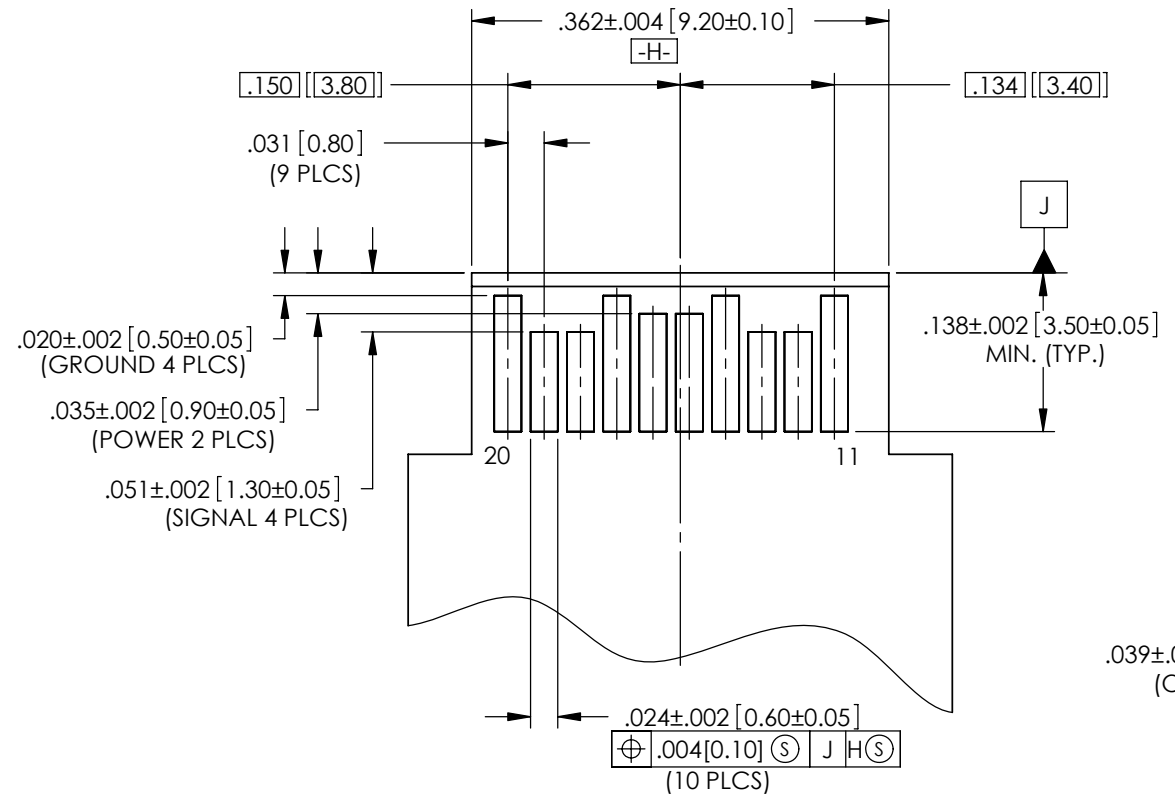

TOP VIEW OF BOAD

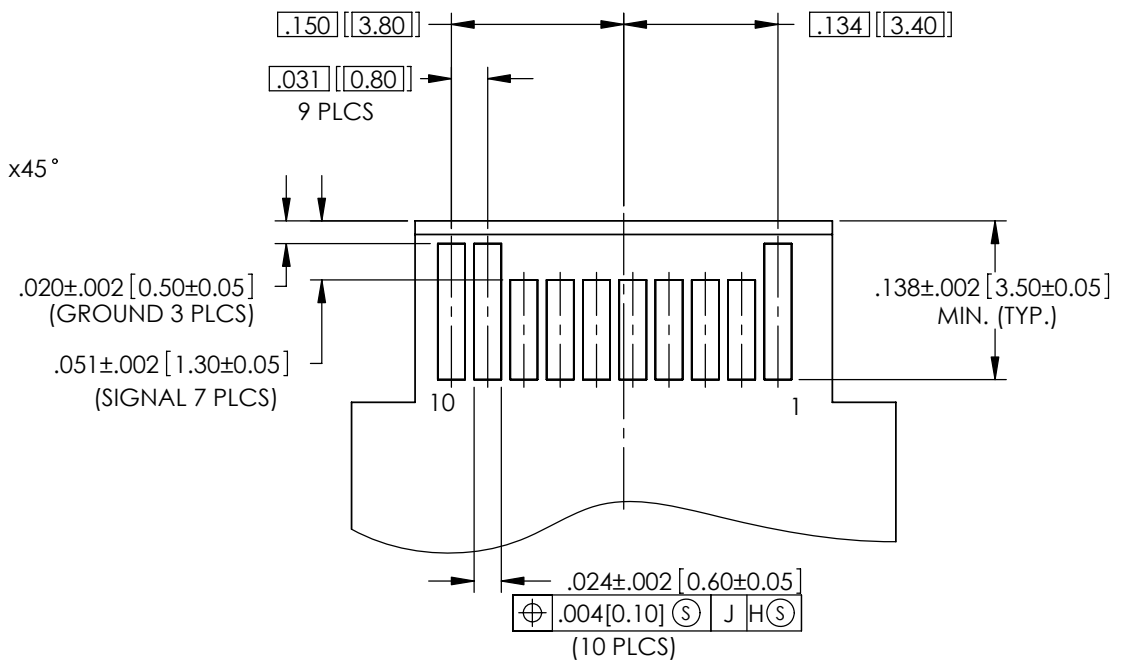
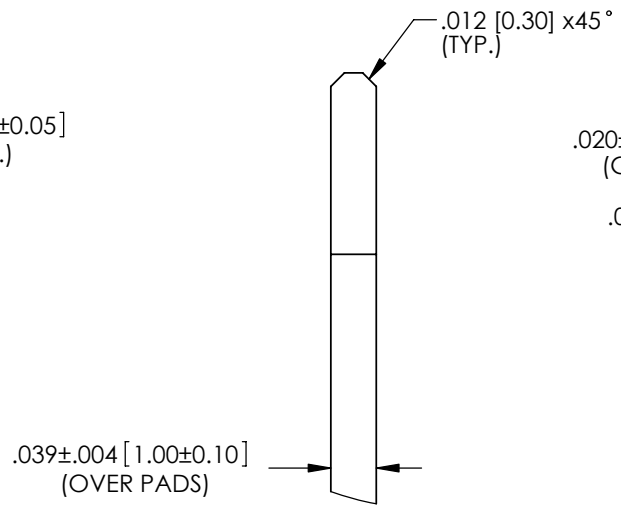

BOTTOM VIEW OF BOAD

RECOMMENDED LAYOUT DETAIL
MATING TRANSCEIVER PCB

DO NOT SCALE DRAWING

THIS DOCUMENT CONTAINS PROPRIETARY INFORMATION AND SUCH INFORMATION MAY NOT BE DISCLOSED TO OTHERS FOR ANY PURPOSE OR USED FOR MANUFACTURING PUPOSES WITHOUT PERMISSION FROM AMPHENOL CANADA CORP.

APPROVALS		DATE	Amphenol Canada Corp.		
DRAWN	A.LIU	2006/02/13	TITLE SFP CAGE + CONNECTOR 1X1 8 PRESS FIT / 12 EMI PINS		
DESIGNED	J.SI	2006/02/13			
CHECKED	J.SI	2006/02/13			
QA APPD	X	X			
IE APPD	X	X	SIZE A3	DWG. NO. P-UE78-A1118-0XXXX	REV. D
DWG APPD			SCALE 4:1	PROJECT	SHEET 4 OF 7

REVISIONS

REV.	ECN/E-R	DESCRIPTION	DATE	APPROVED
B		CUSTOMER DRAWING	2006/04/05	J.SI
C		UPDATED	2006/08/09	
D		UPDATED	2007/01/02	

NOTES;
 1. DATUM AND BASIC DIMENTIONS ESTABLISHED BY CUSTOMER
 2. PADS AND VIAS ARE CHASSIS GROUND, 11 PLACES.
 3. THROUGH HOLES, PLATING OPTIONAL.

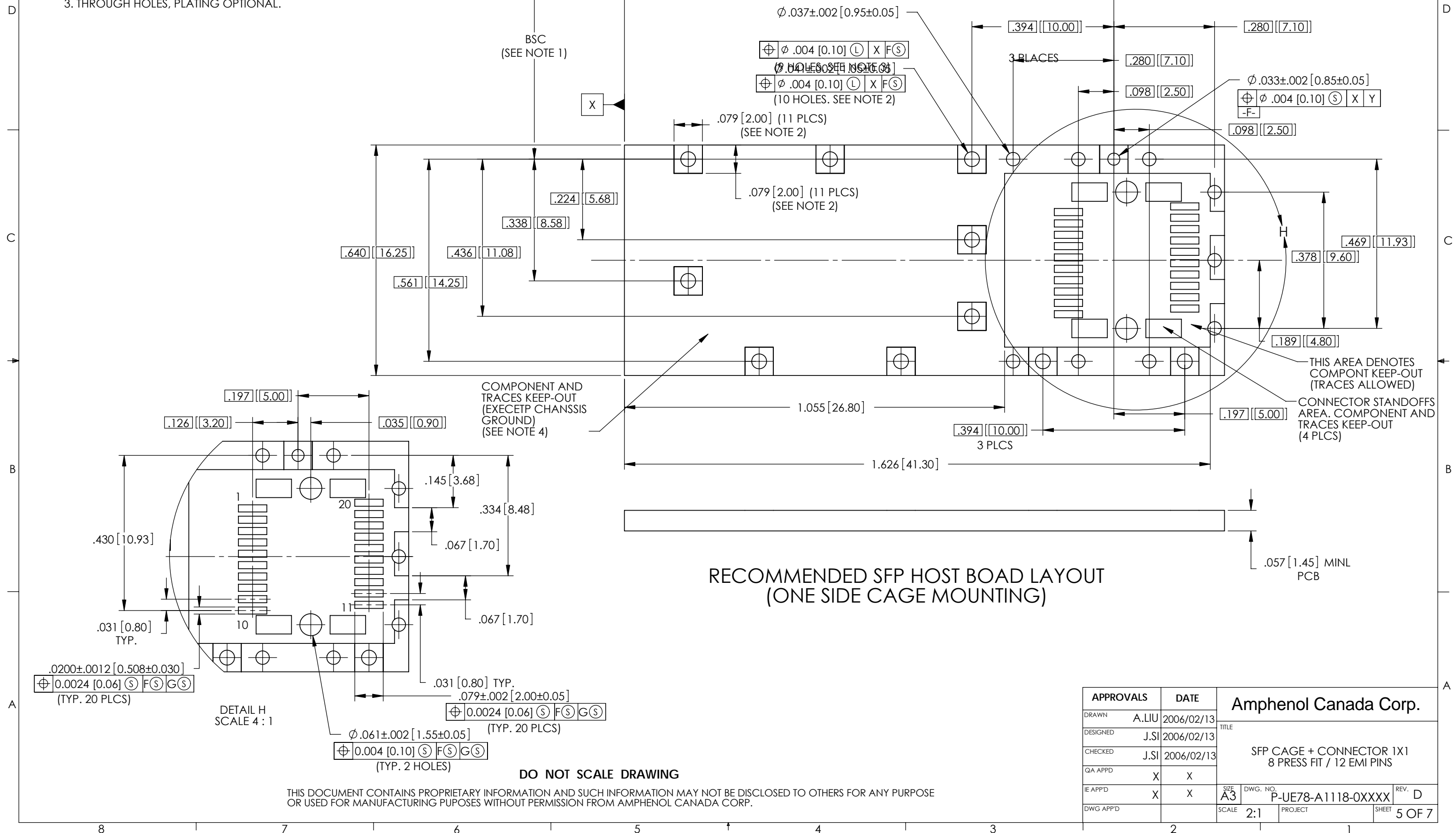

BSC
(SEE NOTE 1)

$\phi .004 [0.10] \text{ (L) X F (S)}$
 $\phi .004 [0.10] \text{ (L) X F (S)}$
 (10 HOLES. SEE NOTE 2)

$\phi .033 \pm .002 [0.85 \pm 0.05]$
 $\phi .004 [0.10] \text{ (S) X Y}$
 -F-

COMPONENT AND TRACES KEEP-OUT (EXCEPT CHASSIS GROUND) (SEE NOTE 4)

THIS AREA DENOTES COMPONENT KEEP-OUT (TRACES ALLOWED)
 CONNECTOR STANDOFFS AREA. COMPONENT AND TRACES KEEP-OUT (4 PLCS)

RECOMMENDED SFP HOST BOARD LAYOUT (ONE SIDE CAGE MOUNTING)

DETAIL H
SCALE 4 : 1

DO NOT SCALE DRAWING

THIS DOCUMENT CONTAINS PROPRIETARY INFORMATION AND SUCH INFORMATION MAY NOT BE DISCLOSED TO OTHERS FOR ANY PURPOSE OR USED FOR MANUFACTURING PUPOSES WITHOUT PERMISSION FROM AMPHENOL CANADA CORP.

APPROVALS		DATE	Amphenol Canada Corp.	
DRAWN	A.LIU	2006/02/13	TITLE	
DESIGNED	J.SI	2006/02/13	SFP CAGE + CONNECTOR 1X1 8 PRESS FIT / 12 EMI PINS	
CHECKED	J.SI	2006/02/13	SIZE	DWG. NO.
QA APPD	X	X	A3	P-UE78-A1118-0XXXX
IE APPD	X	X	SCALE	REV. D
DWG APPD			2:1	PROJECT SHEET 5 OF 7

REVISIONS				
REV.	ECN/E-R	DESCRIPTION	DATE	APPROVED
B		CUSTOMER DRAWING	2006/04/05	J.SI
C		UPDATED	2006/08/09	
D		UPDATED	2007/01/02	

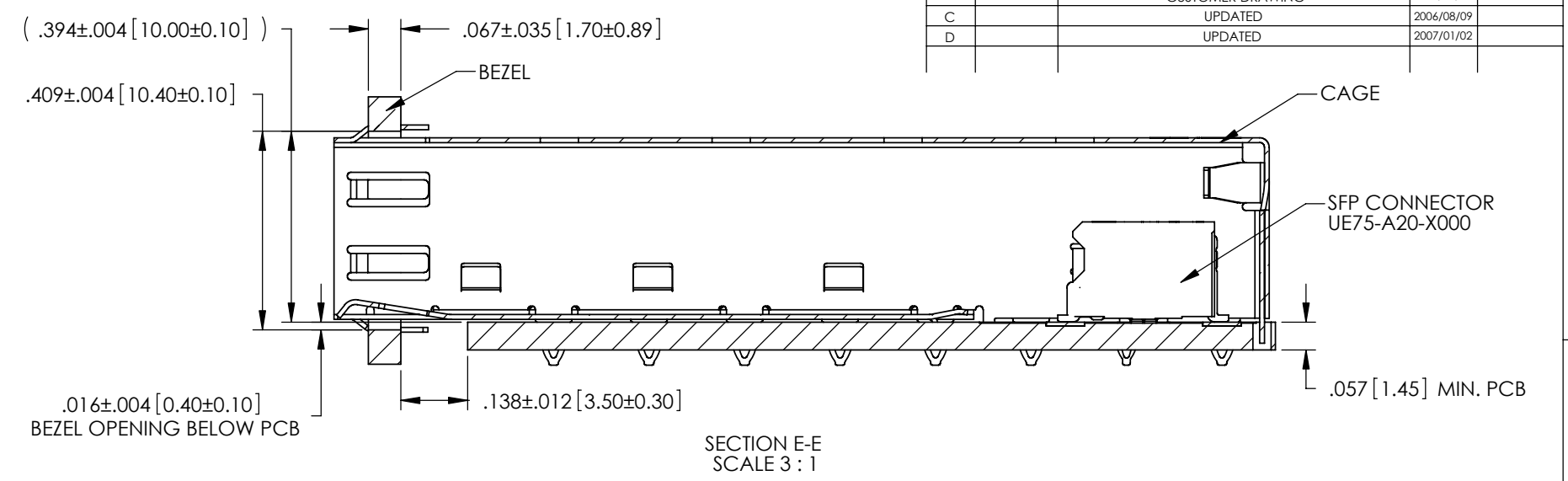
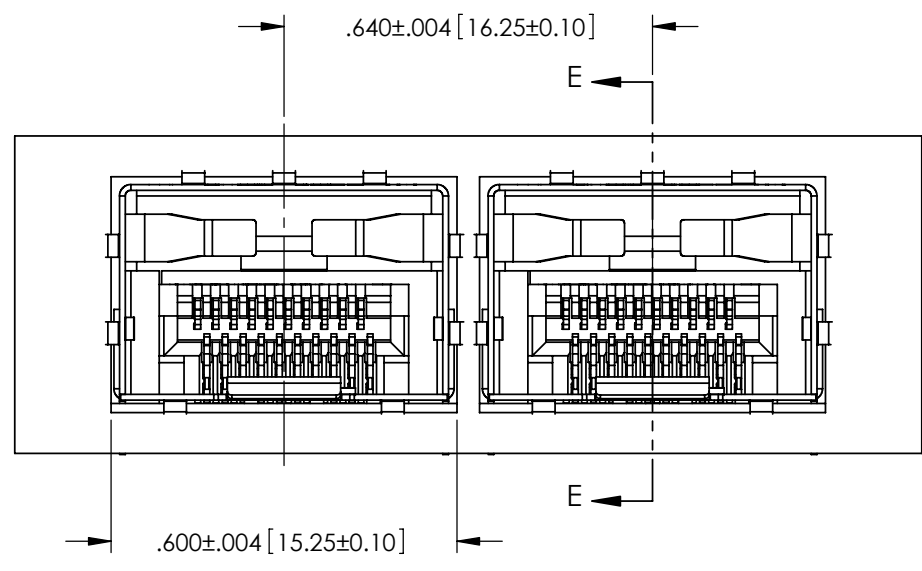

RECOMMENDED BEZEL DESIGN
(ONE SIDE CAGE MOUNTING)

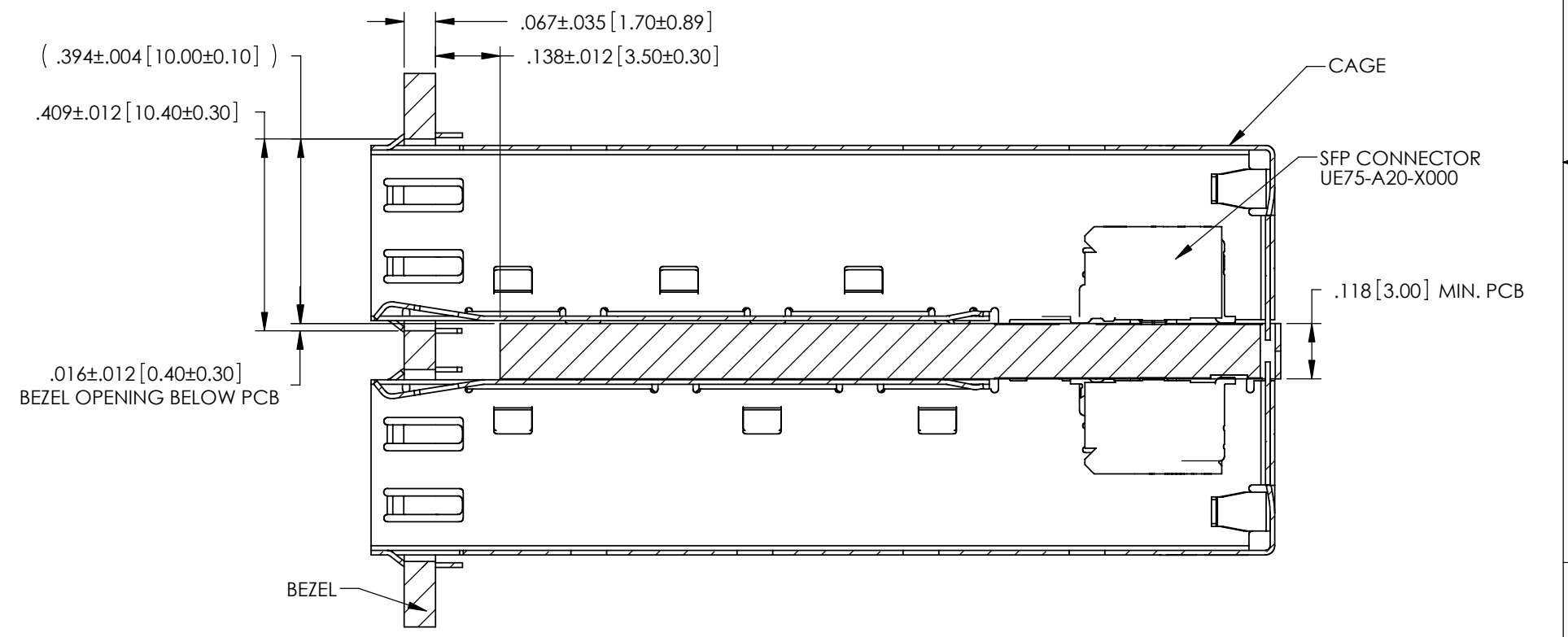
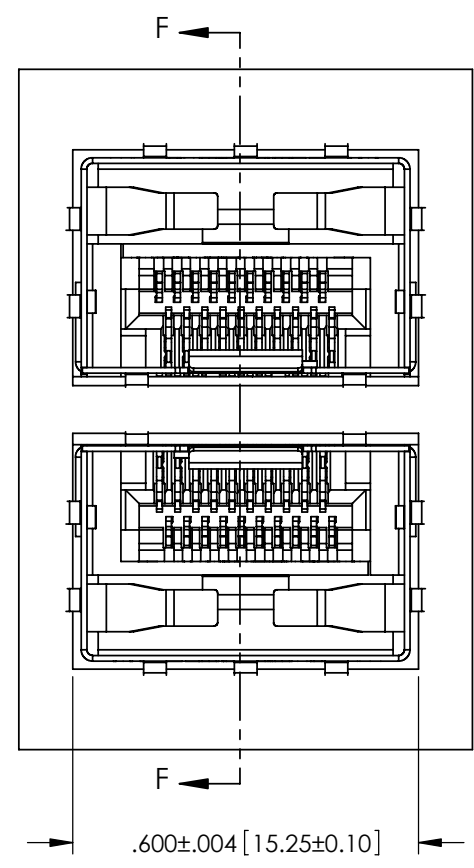

RECOMMENDED BEZEL DESIGN
(BELLY TO BELLY CAGE MOUNTING)

DO NOT SCALE DRAWING

THIS DOCUMENT CONTAINS PROPRIETARY INFORMATION AND SUCH INFORMATION MAY NOT BE DISCLOSED TO OTHERS FOR ANY PURPOSE OR USED FOR MANUFACTURING PUPOSES WITHOUT PERMISSION FROM AMPHENOL CANADA CORP.

APPROVALS		DATE	Amphenol Canada Corp.		
DRAWN	A.LIU	2006/02/13	TITLE		
DESIGNED	J.SI	2006/02/13	SFP CAGE + CONNECTOR 1X1 8 PRESS FIT / 12 EMI PINS		
CHECKED	J.SI	2006/02/13	REV. D		
QA APPD	X	X	SIZE A3	DWG. NO. P-UE78-A1118-0XXXX	REV. D
IE APPD	X	X	SCALE 2:1	PROJECT	SHEET 6 OF 7
DWG APPD					

REVISIONS				
REV.	ECN/E-R	DESCRIPTION	DATE	APPROVED
B		CUSTOMER DRAWING	2006/04/05	
C		UPDATED	2006/08/09	
D		UPDATED	2007/01/02	

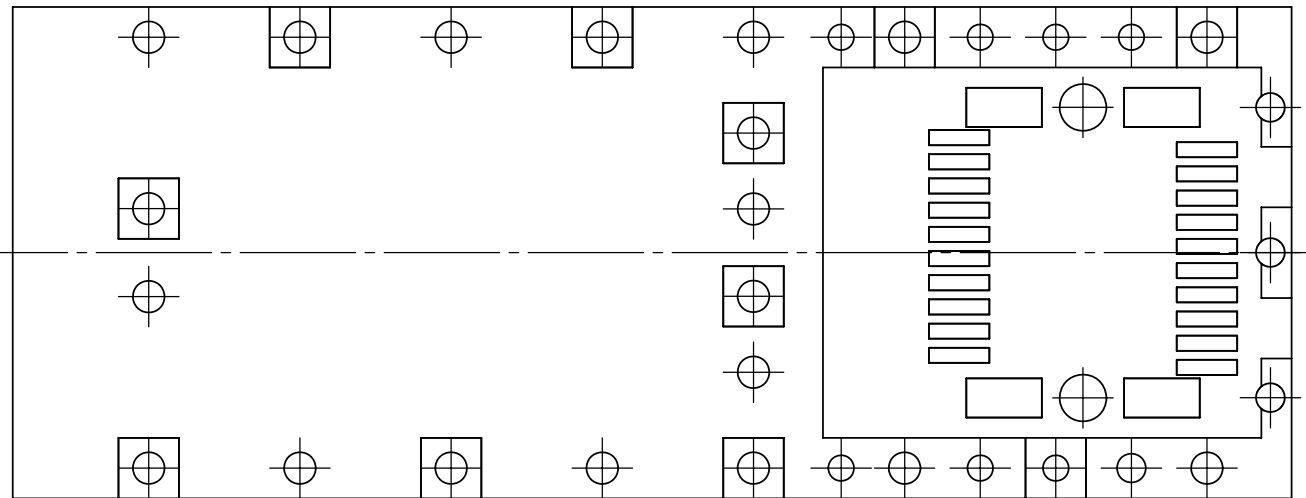
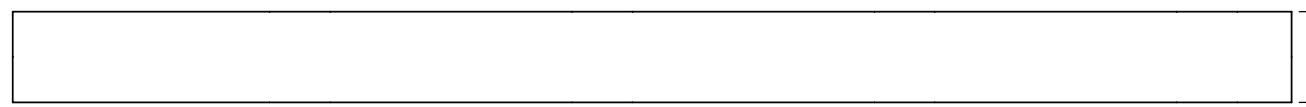
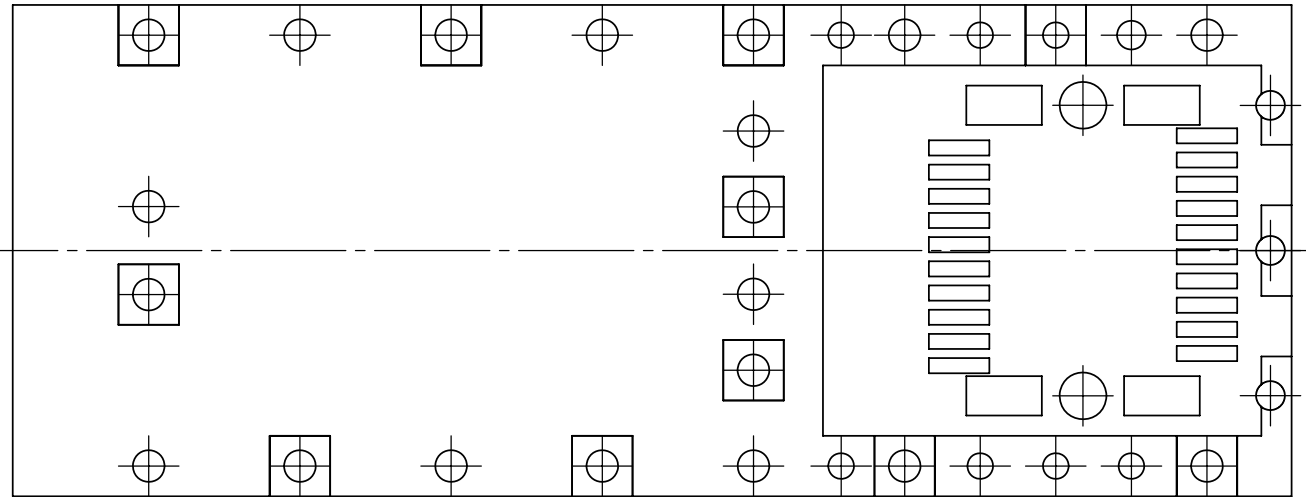

RECOMMENDED SFP HOST BOARD LAYOUT
(BELLY TO BELLY CAGE MOUNTING)

DO NOT SCALE DRAWING

THIS DOCUMENT CONTAINS PROPRIETARY INFORMATION AND SUCH INFORMATION MAY NOT BE DISCLOSED TO OTHERS FOR ANY PURPOSE OR USED FOR MANUFACTURING PUPOSES WITHOUT PERMISSION FROM AMPHENOL CANADA CORP.

APPROVALS		DATE	Amphenol Canada Corp.		
DRAWN	A.LIU	2006/02/13	SFP CAGE + CONNECTOR 1X1 8 PRESS FIT / 12 EMI PINS		
DESIGNED	J.SI	2006/02/13			
CHECKED	J.SI	2006/02/13			
QA APPD	X	X			
IE APPD	X	X	SIZE A3 DWG. NO. P-UE78-A1118-0XXXX SCALE 2:1	PROJECT SHEET 7 OF 7	REV. D

Данный компонент на территории Российской Федерации

Вы можете приобрести в компании MosChip.

Для оперативного оформления запроса Вам необходимо перейти по данной ссылке:

<http://moschip.ru/get-element>

Вы можете разместить у нас заказ для любого Вашего проекта, будь то серийное производство или разработка единичного прибора.

В нашем ассортименте представлены ведущие мировые производители активных и пассивных электронных компонентов.

Нашей специализацией является поставка электронной компонентной базы двойного назначения, продукции таких производителей как XILINX, Intel (ex.ALTERA), Vicor, Microchip, Texas Instruments, Analog Devices, Mini-Circuits, Amphenol, Glenair.

Сотрудничество с глобальными дистрибьюторами электронных компонентов, предоставляет возможность заказывать и получать с международных складов практически любой перечень компонентов в оптимальные для Вас сроки.

На всех этапах разработки и производства наши партнеры могут получить квалифицированную поддержку опытных инженеров.

Система менеджмента качества компании отвечает требованиям в соответствии с ГОСТ Р ИСО 9001, ГОСТ РВ 0015-002 и ЭС РД 009

Офис по работе с юридическими лицами:

105318, г.Москва, ул.Щербаковская д.3, офис 1107, 1118, ДЦ «Щербаковский»

Телефон: +7 495 668-12-70 (многоканальный)

Факс: +7 495 668-12-70 (доб.304)

E-mail: info@moschip.ru

Skype отдела продаж:

moschip.ru

moschip.ru_4

moschip.ru_6

moschip.ru_9