

64K x 16 HIGH SPEED ASYNCHRONOUS CMOS STATIC RAM WITH ECC

FEBRUARY 2014

FEATURES

- High-speed access time: 8, 10 ns
- Low Active Power: 85 mW (typical)
- Low Standby Power: 7 mW (typical) CMOS standby
- Single power supply
- Fully static operation: no clock or refresh required
- Three state outputs
- Data control for upper and lower bytes
- Industrial and Automotive temperature support
- Lead-free available
- Error Detection and Error Correction

DESCRIPTION

The *ISSI* IS61/64WV6416EEBLL is a high-speed, 1,048,576-bit static RAMs organized as 65,536 words by 16 bits. It is fabricated using *ISSI*'s high-performance CMOS technology. This highly reliable process coupled with innovative circuit design techniques, yields high-performance and low power consumption devices.

When \overline{CE} is HIGH (deselected), the device assumes a standby mode at which the power dissipation can be reduced down with CMOS input levels.

Easy memory expansion is provided by using Chip Enable and Output Enable inputs, \overline{CE} and \overline{OE} . The active LOW Write Enable (\overline{WE}) controls both writing and reading of the memory. A data byte allows Upper Byte (\overline{UB}) and Lower Byte (\overline{LB}) access.

The IS61/64WV6416EEBLL is packaged in the JEDEC standard 44-pin TSOP-II, 48-pin Mini BGA (6mm x 8mm), and 44-pin SOJ.

FUNCTIONAL BLOCK DIAGRAM



Copyright © 2014 Integrated Silicon Solution, Inc. All rights reserved. ISSI reserves the right to make changes to this specification and its products at any time without notice. ISSI assumes no liability arising out of the application or use of any information, products or services described herein. Customers are advised to obtain the latest version of this device specification before relying on any published information and before placing orders for products.

Integrated Silicon Solution, Inc. does not recommend the use of any of its products in life support applications where the failure or malfunction of the product can reasonably be expected to cause failure of the life support system or to significantly affect its safety or effectiveness. Products are not authorized for use in such applications unless Integrated Silicon Solution, Inc. receives written assurance to its satisfaction, that:

- a.) the risk of injury or damage has been minimized;
- b.) the user assume all such risks; and
- c.) potential liability of Integrated Silicon Solution, Inc is adequately protected under the circumstances

TRUTH TABLE

Mode	\overline{WE}	\overline{CE}	\overline{OE}	\overline{LB}	\overline{UB}	I/O PIN		V_{DD} Current
						I/O0-I/O7	I/O8-I/O15	
Not Selected	X	H	X	X	X	High-Z	High-Z	IsB1, IsB2
Output Disabled	H	L	H	X	X	High-Z	High-Z	I _{cc}
	X	L	X	H	H	High-Z	High-Z	
Read	H	L	L	L	H	DOUT	High-Z	I _{cc}
	H	L	L	H	L	High-Z	DOUT	
	H	L	L	L	L	DOUT	DOUT	
Write	L	L	X	L	H	DIN	High-Z	I _{cc}
	L	L	X	H	L	High-Z	DIN	
	L	L	X	L	L	DIN	DIN	

PIN CONFIGURATIONS

44-Pin TSOP-II

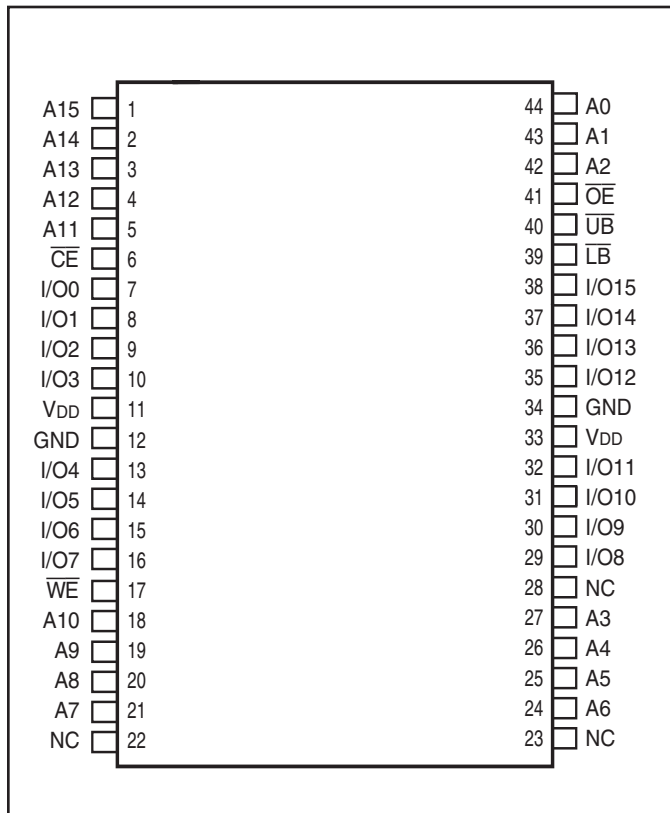

PIN DESCRIPTIONS

A0-A15	Address Inputs
I/O0-I/O15	Data Inputs/Outputs
\overline{CE}	Chip Enable Input
\overline{OE}	Output Enable Input
\overline{WE}	Write Enable Input
\overline{LB}	Lower-byte Control (I/O0-I/O7)
\overline{UB}	Upper-byte Control (I/O8-I/O15)
NC	No Connection
V_{DD}	Power
GND	Ground

PIN CONFIGURATIONS

48-Pin mini BGA (6mm x 8mm)

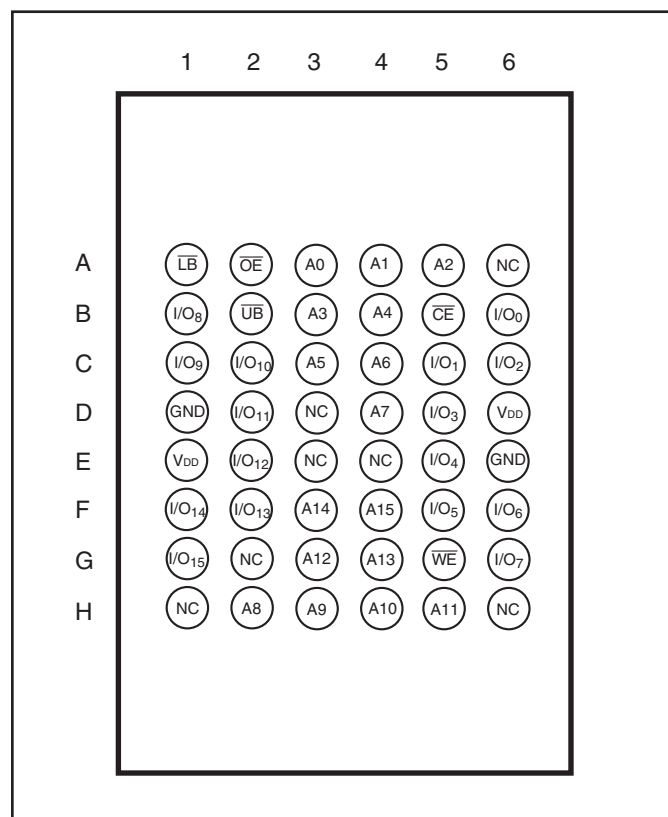

44-Pin SOJ (K)



PIN DESCRIPTIONS

A0-A15	Address Inputs
I/O0-I/O15	Data Inputs/Outputs
CE	Chip Enable Input
OE	Output Enable Input
WE	Write Enable Input
LB	Lower-byte Control (I/O0-I/O7)
UB	Upper-byte Control (I/O8-I/O15)
NC	No Connection
V _{DD}	Power
GND	Ground

ABSOLUTE MAXIMUM RATINGS⁽¹⁾

Symbol	Parameter	Value	Unit
V _{TERM}	Terminal Voltage with Respect to GND	-0.5 to V _{DD} + 0.5	V
V _{DD}	V _{DD} Relates to GND	-0.3 to 4.0	V
T _{STG}	Storage Temperature	-65 to +150	°C
P _T	Power Dissipation	1.0	W

Notes:

1. Stress greater than those listed under ABSOLUTE MAXIMUM RATINGS may cause permanent damage to the device. This is a stress rating only and functional operation of the device at these or any other conditions above those indicated in the operational sections of this specification is not implied. Exposure to absolute maximum rating conditions for extended periods may affect reliability.

CAPACITANCE^(1,2)

Symbol	Parameter	Conditions	Max.	Unit
C _{IN}	Input Capacitance	V _{IN} = 0V	6	pF
C _{I/O}	Input/Output Capacitance	V _{OUT} = 0V	8	pF

Notes:

1. Tested initially and after any design or process changes that may affect these parameters.
2. Test conditions: T_A = 25°C, f = 1 MHz, V_{DD} = 3.3V.

ERROR DETECTION AND ERROR CORRECTION

- Independent ECC with hamming code for each byte
- Detect and correct one bit error per byte
- Better reliability than parity code schemes which can only detect an error but not correct an error
- Backward Compatible: Drop in replacement to current in industry standard devices (without ECC)

OPERATING RANGE (V_{DD})¹

Range	Ambient Temperature	IS61WV6416EEBLL V _{DD} (8, 10ns)	IS64WV6416EEBLL V _{DD} (8, 10ns)
Industrial	-40°C to +85°C	2.4V-3.6V	—
Automotive (A1)	-40°C to +85°C	—	2.4V-3.6V (8,10ns)
Automotive (A3)	-40°C to +125°C	—	2.4V-3.6V (10ns)

Note:

1. Contact SRAM@issi.com for 1.8V option

IS61/64WV6416EEBLL

DC ELECTRICAL CHARACTERISTICS (Over Operating Range)

$V_{DD} = 3.3V \pm 10\%$

Symbol	Parameter	Test Conditions	Min.	Max.	Unit
V_{OH}	Output HIGH Voltage	$V_{DD} = \text{Min.}, I_{OH} = -4.0 \text{ mA}$	2.4	—	V
V_{OL}	Output LOW Voltage	$V_{DD} = \text{Min.}, I_{OL} = 8.0 \text{ mA}$	—	0.4	V
V_{IH}	Input HIGH Voltage		2	$V_{DD} + 0.3$	V
V_{IL}	Input LOW Voltage ⁽¹⁾		-0.3	0.8	V
I_{LI}	Input Leakage	$GND \leq V_{IN} \leq V_{DD}$	-1	1	μA
I_{LO}	Output Leakage	$GND \leq V_{OUT} \leq V_{DD}$, Outputs Disabled	-1	1	μA

Note:

- V_{IL} (min.) = -0.3V DC; V_{IL} (min.) = -2.0V AC (pulse width < 2 ns). Not 100% tested.
 V_{IH} (max.) = $V_{DD} + 0.3V$ DC; V_{IH} (max.) = $V_{DD} + 2.0V$ AC (pulse width < 2 ns). Not 100% tested.

DC ELECTRICAL CHARACTERISTICS (Over Operating Range)

$V_{DD} = 2.4V-3.6V$

Symbol	Parameter	Test Conditions	Min.	Max.	Unit
V_{OH}	Output HIGH Voltage	$V_{DD} = \text{Min.}, I_{OH} = -1.0 \text{ mA}$	1.8	—	V
V_{OL}	Output LOW Voltage	$V_{DD} = \text{Min.}, I_{OL} = 1.0 \text{ mA}$	—	0.4	V
V_{IH}	Input HIGH Voltage		2.0	$V_{DD} + 0.3$	V
V_{IL}	Input LOW Voltage ⁽¹⁾		-0.3	0.8	V
I_{LI}	Input Leakage	$GND \leq V_{IN} \leq V_{DD}$	-1	1	μA
I_{LO}	Output Leakage	$GND \leq V_{OUT} \leq V_{DD}$, Outputs Disabled	-1	1	μA

Note:

- V_{IL} (min.) = -0.3V DC; V_{IL} (min.) = -2.0V AC (pulse width < 2 ns). Not 100% tested.
 V_{IH} (max.) = $V_{DD} + 0.3V$ DC; V_{IH} (max.) = $V_{DD} + 2.0V$ AC (pulse width < 2 ns). Not 100% tested.

POWER SUPPLY CHARACTERISTICS⁽¹⁾ (Over Operating Range)

Symbol	Parameter	Test Conditions	-8		-10		-20		Unit	
			Min.	Max.	Min.	Max.	Min.	Max.		
I_{CC}	V_{DD} Dynamic Operating Supply Current	$V_{DD} = \text{Max.}, I_{OUT} = 0 \text{ mA}, f = f_{MAX}$	Com.	—	25	—	20	—	15	mA
			Ind.	—	30	—	25	—	20	
			Auto.	—	—	—	35	—	30	
			typ. ⁽²⁾	15	15					
I_{CC1}	Operating Supply Current	$V_{DD} = \text{Max.}, I_{OUT} = 0 \text{ mA}, f = 0$	Com.	—	10	—	10	—	10	mA
			Ind.	—	12	—	12	—	12	
			Auto.	—	—	—	15	—	15	
I_{SB1}	TTL Standby Current (TTL Inputs)	$V_{DD} = \text{Max.}, V_{IN} = V_{IH} \text{ or } V_{IL}, \overline{CE} \geq V_{IH}, f = 0$	Com.	—	10	—	10	—	10	mA
			Ind.	—	12	—	12	—	12	
			Auto.	—	—	—	20	—	20	
I_{SB2}	CMOS Standby Current (CMOS Inputs)	$V_{DD} = \text{Max.}, \overline{CE} \geq V_{DD} - 0.2V, V_{IN} \geq V_{DD} - 0.2V \text{ or } V_{IN} \leq 0.2V, f = 0$	Com.	—	3	—	3	—	3	mA
			Ind.	—	4	—	4	—	4	
			Auto.	—	—	—	10	—	10	
			typ. ⁽²⁾	1	1					

Note:

- At $f = f_{MAX}$, address and data inputs are cycling at the maximum frequency, $f = 0$ means no input lines change.
- Typical values are measured at $V_{DD} = 3.0V, T_A = 25^\circ\text{C}$ and not 100% tested.

AC TEST CONDITIONS

Parameter	Unit (2.4V-3.6V)
Input Pulse Level	0.4V to $V_{DD}-0.3V$
Input Rise and Fall Times	1V/ ns
Input and Output Timing and Reference Level (V_{Ref})	$V_{DD}/2$
Output Load	See Figures 1 and 2

AC TEST LOADS

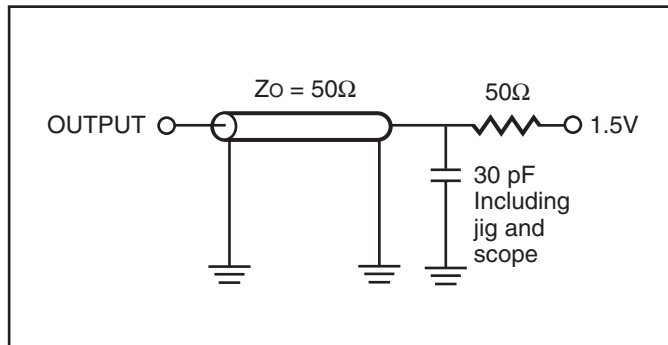

Figure 1.



Figure 2.

READ CYCLE SWITCHING CHARACTERISTICS⁽¹⁾ (Over Operating Range)

Symbol	Parameter	-8		-10		-20		Unit
		Min.	Max.	Min.	Max.	Min.	Max.	
t_{RC}	Read Cycle Time	8	—	10	—	20	—	ns
t_{AA}	Address Access Time	—	8	—	10	—	20	ns
t_{OHA}	Output Hold Time	2.0	—	2.0	—	2.5	—	ns
t_{ACE}	\overline{CE} Access Time	—	8	—	10	—	20	ns
t_{DOE}	\overline{OE} Access Time	—	4.5	—	4.5	—	8	ns
$t_{HZOE}^{(2)}$	\overline{OE} to High-Z Output	—	3	—	4	0	8	ns
$t_{LZOE}^{(2)}$	\overline{OE} to Low-Z Output	0	—	0	—	0	—	ns
$t_{HZCE}^{(2)}$	\overline{CE} to High-Z Output	0	3	0	4	0	8	ns
$t_{LZCE}^{(2)}$	\overline{CE} to Low-Z Output	3	—	3	—	3	—	ns
t_{BA}	\overline{LB} , \overline{UB} Access Time	—	5.5	—	6.5	—	8	ns
$t_{HZB}^{(2)}$	\overline{LB} , \overline{UB} to High-Z Output	0	3	0	3	0	8	ns
$t_{LZB}^{(2)}$	\overline{LB} , \overline{UB} to Low-Z Output	0	—	0	—	0	—	ns
t_{PU}	Power Up Time	0	—	0	—	0	—	ns
t_{PD}	Power Down Time	—	8	—	10	—	20	ns

Notes:

1. Test conditions and output loading conditions are specified in the AC Test Conditions and AC Test Loads (Figure 1).
2. Tested with the load in Figure 2. Transition is measured ± 500 mV from steady-state voltage.

AC WAVEFORMS

READ CYCLE NO. 1^(1,2) (Address Controlled) ($\overline{CE} = \overline{OE} = V_{IL}$, \overline{UB} or $\overline{LB} = V_{IL}$)

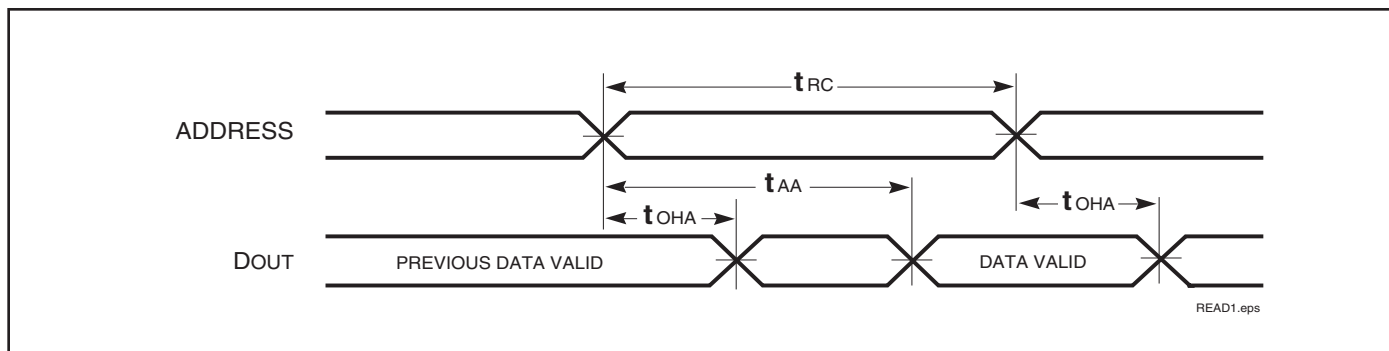

READ CYCLE NO. 2^(1,3)

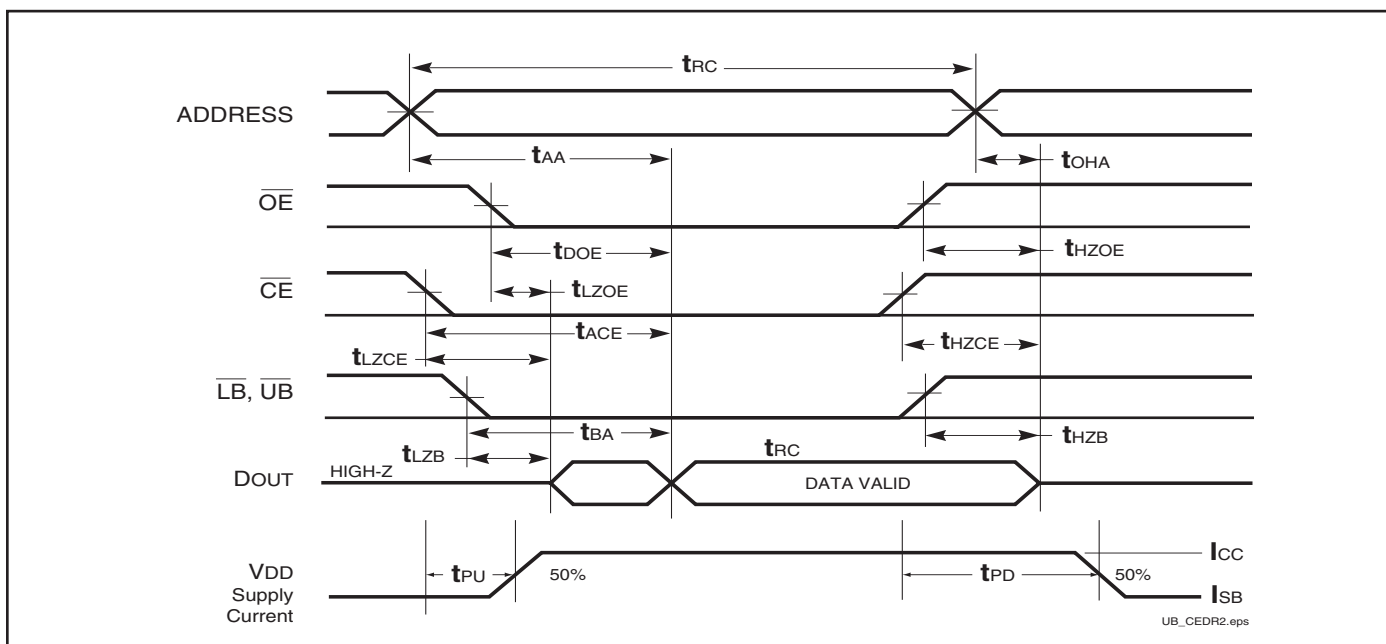

Notes:

1. \overline{WE} is HIGH for a Read Cycle.
2. The device is continuously selected. \overline{OE} , \overline{CE} , \overline{UB} , or $\overline{LB} = V_{IL}$.
3. Address is valid prior to or coincident with \overline{CE} LOW transition.

WRITE CYCLE SWITCHING CHARACTERISTICS^(1,3) (Over Operating Range)

Symbol	Parameter	-8		-10		-20		Unit
		Min.	Max.	Min.	Max.	Min.	Max.	
t _{WC}	Write Cycle Time	8	—	10	—	20	—	ns
t _{SCE}	\overline{CE} to Write End	6.5	—	8	—	12	—	ns
t _{AW}	Address Setup Time to Write End	6.5	—	8	—	12	—	ns
t _{HA}	Address Hold from Write End	0	—	0	—	0	—	ns
t _{SA}	Address Setup Time	0	—	0	—	0	—	ns
t _{PWB}	\overline{LB} , \overline{UB} Valid to End of Write	6.5	—	8	—	12	—	ns
t _{PWE1}	\overline{WE} Pulse Width	6.5	—	8	—	12	—	ns
t _{PWE2}	\overline{WE} Pulse Width ($\overline{OE} = \text{LOW}$)	8	—	10	—	17	—	ns
t _{SD}	Data Setup to Write End	5	—	6	—	9	—	ns
t _{HD}	Data Hold from Write End	0	—	0	—	0	—	ns
t _{HZWE⁽²⁾}	\overline{WE} LOW to High-Z Output	—	3.5	—	5	—	9	ns
t _{LZWE⁽²⁾}	\overline{WE} HIGH to Low-Z Output	2	—	2	—	3	—	ns

Notes:

1. Test conditions and output loading conditions are specified in the AC Test Conditions and AC Test Loads (Figure 1).
2. Tested with the load in Figure 2. Transition is measured ± 500 mV from steady-state voltage. Not 100% tested.
3. The internal write time is defined by the overlap of \overline{CE} LOW and \overline{UB} or \overline{LB} , and \overline{WE} LOW. All signals must be in valid states to initiate a Write, but any one can go inactive to terminate the Write. The Data Input Setup and Hold timing are referenced to the rising or falling edge of the signal that terminates the write. Shaded area product in development

AC WAVEFORMS

WRITE CYCLE NO. 1 (\overline{CE} Controlled, \overline{OE} is HIGH or LOW) ⁽¹⁾

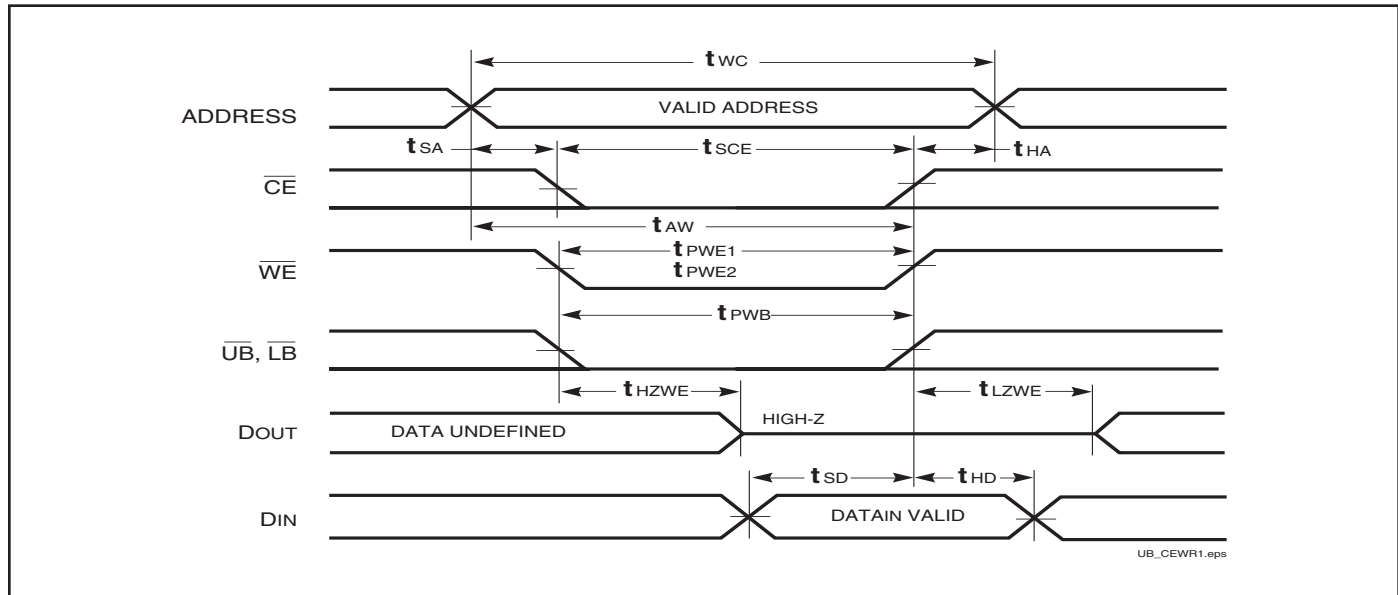

Notes:

1. WRITE is an internally generated signal asserted during an overlap of the LOW states on the \overline{CE} and \overline{WE} inputs and at least one of the \overline{LB} and \overline{UB} inputs being in the LOW state.
2. WRITE = (\overline{CE}) [(\overline{LB}) = (\overline{UB})] (\overline{WE}).

WRITE CYCLE NO. 2 (\overline{WE} Controlled. \overline{OE} is HIGH During Write Cycle) ^(1,2)

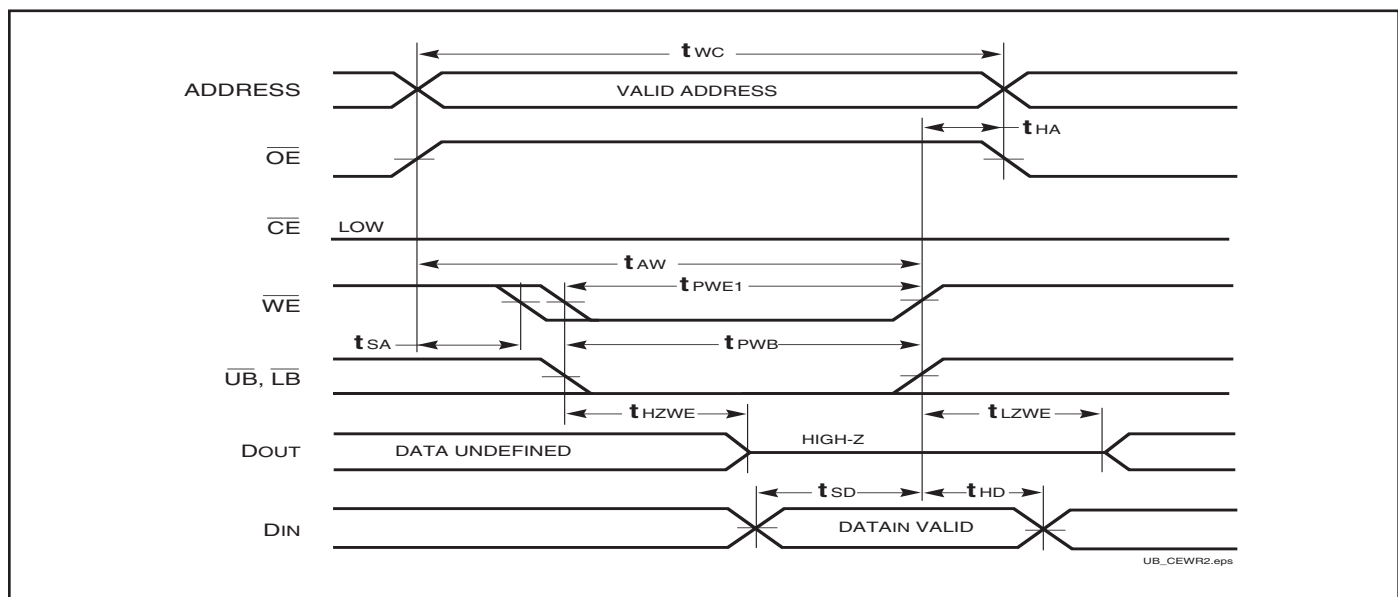

AC WAVEFORMS

WRITE CYCLE NO. 3 (\overline{WE} Controlled, \overline{OE} is LOW During Write Cycle) ⁽¹⁾

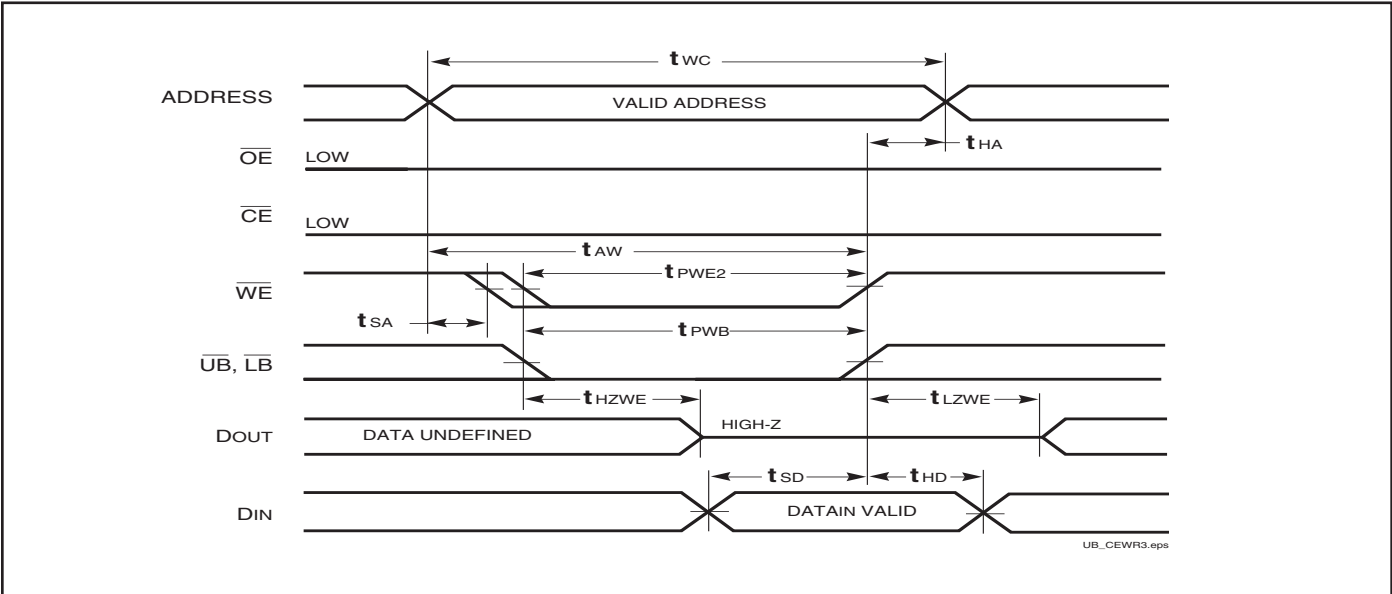

WRITE CYCLE NO. 4 (\overline{LB} , \overline{UB} Controlled, Back-to-Back Write) ^(1,3)

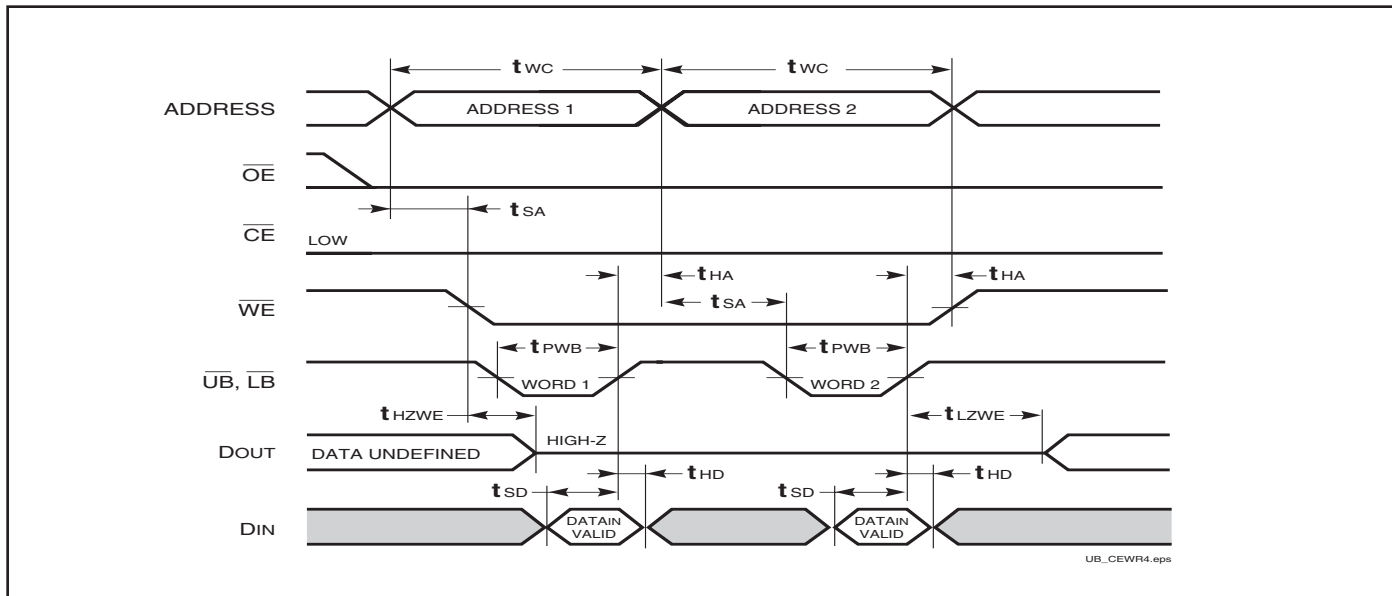

Notes:

1. The internal Write time is defined by the overlap of $\overline{CE} = \text{LOW}$, \overline{UB} and/or $\overline{LB} = \text{LOW}$, and $\overline{WE} = \text{LOW}$. All signals must be in valid states to initiate a Write, but any can be deasserted to terminate the Write. The t_{SA} , t_{HA} , t_{SD} , and t_{HD} timing is referenced to the rising or falling edge of the signal that terminates the Write.
2. Tested with \overline{OE} HIGH for a minimum of 4 ns before $\overline{WE} = \text{LOW}$ to place the I/O in a HIGH-Z state.
3. \overline{WE} may be held LOW across many address cycles and the \overline{LB} , \overline{UB} pins can be used to control the Write function.

HIGH SPEED (IS61/64WV6416EEBLL)

DATA RETENTION SWITCHING CHARACTERISTICS (2.4V-3.6V)

Symbol	Parameter	Test Condition	Options	Min.	Typ. ⁽¹⁾	Max.	Unit
V_{DR}	V_{DD} for Data Retention	See Data Retention Waveform		2.0	—	3.6	V
I_{DR}	Data Retention Current	$V_{DD} = V_{DR}(\text{min})$, $\overline{CE} \geq V_{DD} - 0.2V$, $V_{IN} \geq V_{DD} - 0.2V$ or $V_{IN} \leq 0.2V$	Com. Ind. Auto.	—	0.5	3 4 10	mA
t_{SDR}	Data Retention Setup Time	See Data Retention Waveform		0	—	—	ns
t_{RDR}	Recovery Time	See Data Retention Waveform		t_{RC}	—	—	ns

Note 1: Typical values are measured at $V_{DD} = V_{DR}(\text{min})$, $T_A = 25^\circ\text{C}$ and not 100% tested.

DATA RETENTION WAVEFORM (\overline{CE} Controlled)



IS61/64WV6416EEBLL

ORDERING INFORMATION (HIGH SPEED)

Industrial Range: -40°C to +85°C

Speed (ns)	Order Part No.	Package
8	IS61WV6416EEBLL-8BI	48 mini BGA (6mm x 8mm)
	IS61WV6416EEBLL-8BLI	48 mini BGA (6mm x 8mm), Lead-free
	IS61WV6416EEBLL-8TI	TSOP (Type II)
	IS61WV6416EEBLL-8TLI	TSOP (Type II), Lead-free
10	IS61WV6416EEBLL-10BI	48 mini BGA (6mm x 8mm)
	IS61WV6416EEBLL-10BLI	48 mini BGA (6mm x 8mm), Lead-free
	IS61WV6416EEBLL-10TI	TSOP (Type II)
	IS61WV6416EEBLL-10TLI	TSOP (Type II), Lead-free

Automotive A1 Range: -40°C to +85°C

Speed (ns)	Order Part No.	Package
8	IS64WV6416EEBLL-8BA1	48 mini BGA (6mm x 8mm)
	IS64WV6416EEBLL-8BLA1	48 mini BGA (6mm x 8mm), Lead-free
	IS64WV6416EEBLL-8CTA1	TSOP (Type II), Copper Leadframe
	IS64WV6416EEBLL-8CTLA1	TSOP (Type II), Lead-free, Copper Leadframe
10	IS64WV6416EEBLL-10BA1	48 mini BGA (6mm x 8mm)
	IS64WV6416EEBLL-10BLA1	48 mini BGA (6mm x 8mm), Lead-free
	IS64WV6416EEBLL-10CTA1	TSOP (Type II), Copper Leadframe
	IS64WV6416EEBLL-10CTLA1	TSOP (Type II), Lead-free, Copper Leadframe

Automotive A3 Range: -40°C to +125°C

Speed (ns)	Order Part No.	Package
10	IS64WV6416EEBLL-10BA3	48 mini BGA (6mm x 8mm)
	IS64WV6416EEBLL-10BLA3	48 mini BGA (6mm x 8mm), Lead-free
	IS64WV6416EEBLL-10CTA3	TSOP (Type II), Copper Leadframe
	IS64WV6416EEBLL-10CTLA3	TSOP (Type II), Lead-free, Copper Leadframe

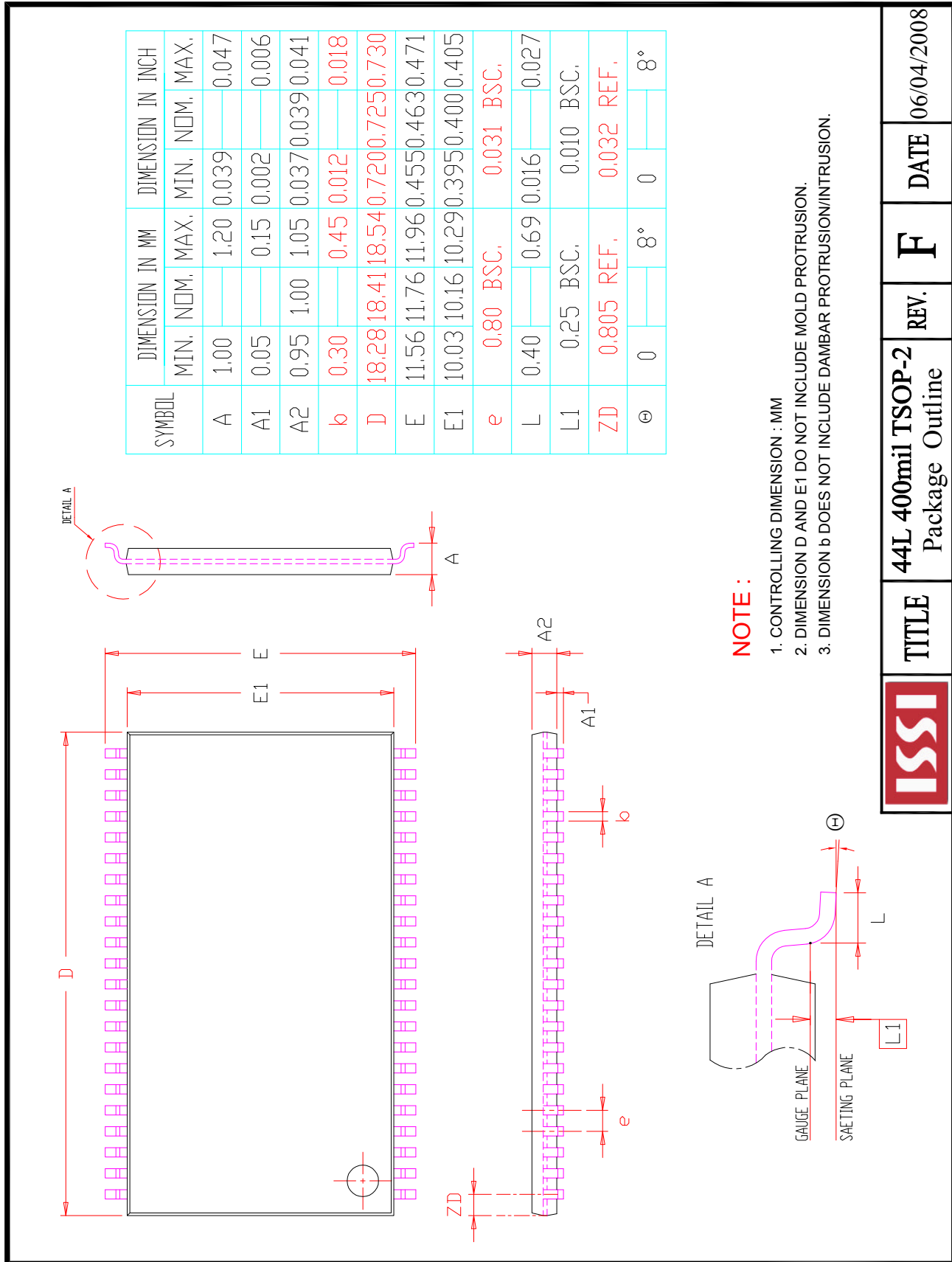

SYMBOL	DIMENSION IN MM			DIMENSION IN INCH		
	MIN.	NOM.	MAX.	MIN.	NOM.	MAX.
A	1.00		1.20	0.039		0.047
A1	0.05		0.15	0.002		0.006
A2	0.95	1.00	1.05	0.037	0.039	0.041
b	0.30		0.45	0.012		0.018
D	18.28	18.41	18.54	0.720	0.725	0.730
E	11.56	11.76	11.96	0.455	0.463	0.471
E1	10.03	10.16	10.29	0.395	0.400	0.405
e	0.80 BSC.			0.031 BSC.		
L	0.40		0.69	0.016		0.027
L1	0.25 BSC.			0.010 BSC.		
ZD	0.805 REF.			0.032 REF.		
Θ	0		8°	0		8°

NOTE :

1. CONTROLLING DIMENSION : MM
2. DIMENSION D AND E1 DO NOT INCLUDE MOLD PROTRUSION.
3. DIMENSION b DOES NOT INCLUDE DAMBAR PROTRUSION/INTRUSION.

	TITLE	REV.	DATE
	44L 400mil TSOP-2 Package Outline	F	06/04/2008

TOP VIEW

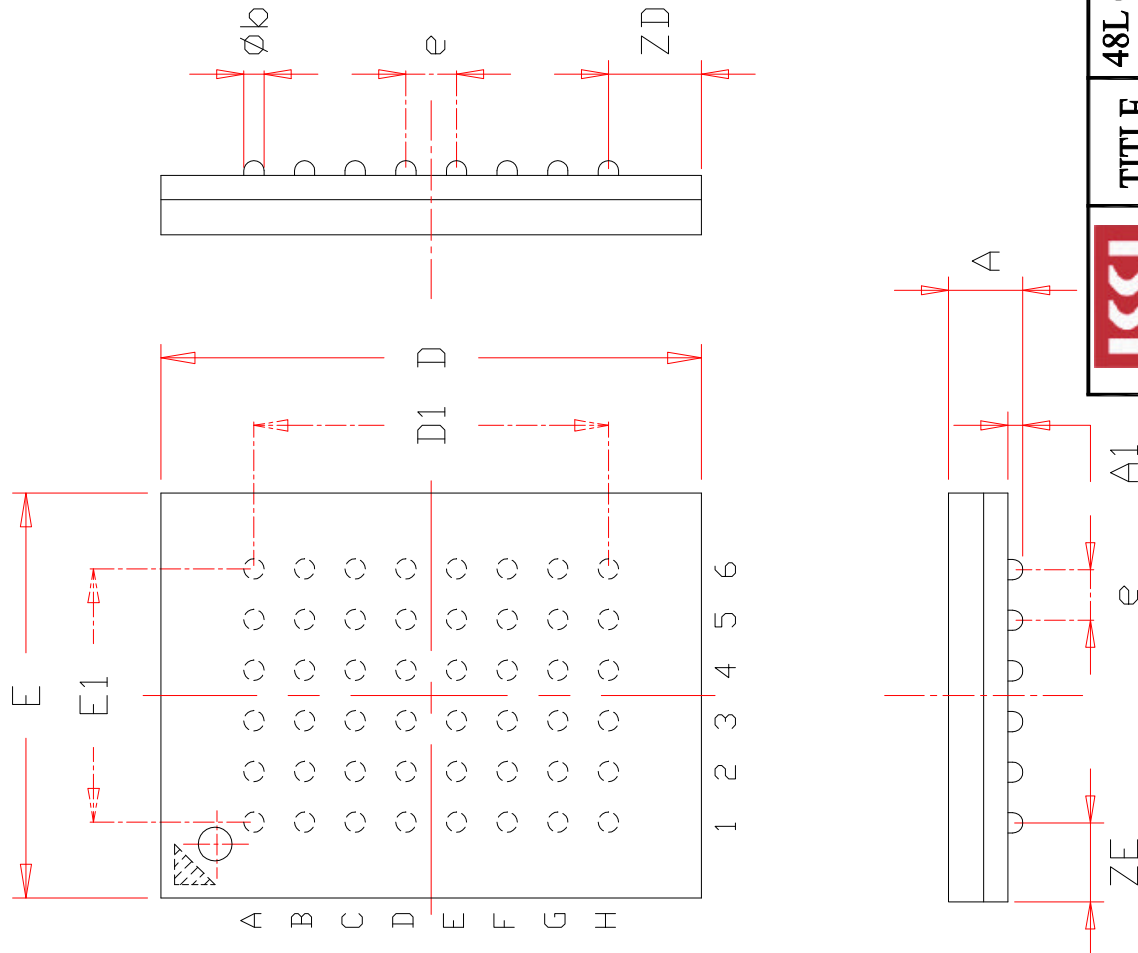

SYMBOL	DIMENSION IN MM		DIMENSION IN INCH	
	MIN.	NOM. MAX.	MIN.	NOM. MAX.
A		1.20		0.047
A1	0.20	0.30	0.008	0.012
ϕb	0.30	0.40	0.012	0.016
D	7.90	8.00	0.311	0.315
D1	5.25	BSC	0.207	BSC
E	5.90	6.00	0.232	0.240
E1	3.75	BSC	0.148	BSC
e	0.75	BSC,	0.030	BSC,
ZD	1.375	REF.	0.054	REF.
ZE	1.125	REF.	0.044	REF.

NOTE :

1. CONTROLLING DIMENSION : MM .
2. Reference document : JEDEC MO-207



TITLE

48L 6x8mm TF-BGA Package Outline

REV.

C

DATE

08/12/2008

SYMBOL	DIMENSION IN MM			DIMENSION IN INCH		
	MIN.	NOM.	MAX.	MIN.	NOM.	MAX.
A	3.25		3.76	0.128		0.148
A1	2.08			0.082		
A3	0.635			0.025		
k	0.38		0.51	0.015		0.020
k2	0.66	0.71	0.81	0.026	0.028	0.032
D	28.45	28.58	28.70	1.120	1.125	1.130
E	11.05	11.18	11.30	0.435	0.440	0.445
E1	10.03	10.16	10.29	0.395	0.400	0.405
E2	9.40	BSC.		0.370	BSC.	
e	1.27	BSC.		0.050	BSC.	
ZD	0.95	REF.		0.037	REF.	

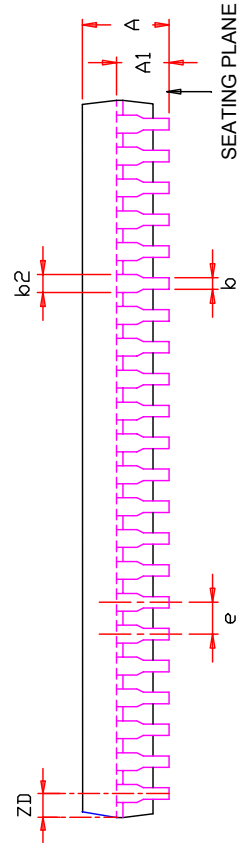
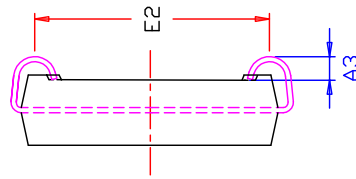
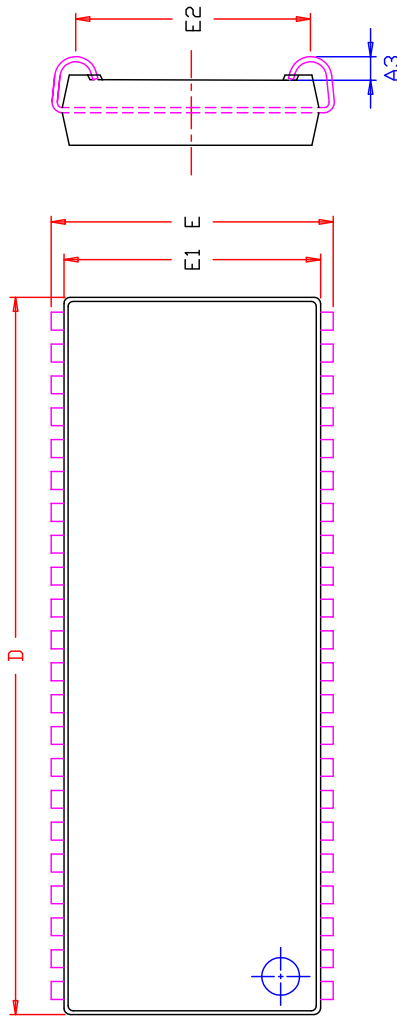

NOTE :

1. Controlling dimension : mm
2. Dimension D and E1 do not include mold protrusion .
3. Dimension b2 does not include dambar protrusion/intrusion.
4. Formed leads shall be planar with respect to one another within 0.1mm at the seating plane after final test.
5. Reference document : JEDEC SPEC MS-027.

	TITLE	44L 400mil SOJ Package Outline	REV.	E	DATE	12/21/2007
--	-------	--------------------------------	------	---	------	------------

Данный компонент на территории Российской Федерации

Вы можете приобрести в компании MosChip.

Для оперативного оформления запроса Вам необходимо перейти по данной ссылке:

<http://moschip.ru/get-element>

Вы можете разместить у нас заказ для любого Вашего проекта, будь то серийное производство или разработка единичного прибора.

В нашем ассортименте представлены ведущие мировые производители активных и пассивных электронных компонентов.

Нашей специализацией является поставка электронной компонентной базы двойного назначения, продукции таких производителей как XILINX, Intel (ex.ALTERA), Vicor, Microchip, Texas Instruments, Analog Devices, Mini-Circuits, Amphenol, Glenair.

Сотрудничество с глобальными дистрибьюторами электронных компонентов, предоставляет возможность заказывать и получать с международных складов практически любой перечень компонентов в оптимальные для Вас сроки.

На всех этапах разработки и производства наши партнеры могут получить квалифицированную поддержку опытных инженеров.

Система менеджмента качества компании отвечает требованиям в соответствии с ГОСТ Р ИСО 9001, ГОСТ РВ 0015-002 и ЭС РД 009

Офис по работе с юридическими лицами:

105318, г.Москва, ул.Щербаковская д.3, офис 1107, 1118, ДЦ «Щербаковский»

Телефон: +7 495 668-12-70 (многоканальный)

Факс: +7 495 668-12-70 (доб.304)

E-mail: info@moschip.ru

Skype отдела продаж:

moschip.ru

moschip.ru_4

moschip.ru_6

moschip.ru_9