

### Description

The THAT1200 Demonstration System is a self-contained circuit board that simplifies evaluation of the THAT1200, THAT1203, and THAT1206 InGenius® line receiver ICs. Completely assembled and tested, this system comes with XLR connectors for signal input and output, and a 3 pin header for connection to an external regulated DC power supply.

J1 is a Female XLR connector that can accept a balanced or unbalanced input signal, while P1, a male XLR connector, delivers an unbalanced output from the IC line receiver. An external  $\pm 15V$  power supply should be connected via header P2 (labeled CN1 on some older revisions of the PCB fabrication).

C1-C3 shunt unwanted RFI currents to chassis ground. The "T" arrangement of these components minimizes CMRR degradation at

high frequencies resulting from any mismatch between C1 and C2, (the shunt paths for each input share C3, and C3's impedance dominates that of C1 and C2). R2 and R3 further improve RFI rejection.

InGenius circuit operation is enabled by bootstrapping the IC's common mode input impedance via C4. CMout is the output of an on-board amplifier connected to sample the common mode voltage at pins 2 and 3. CMIn uses the AC coupled version of this voltage to bootstrap the internal resistors provided to reference the inputs to the Ref pin (typically connected to ground) and to provide a return for the input bias currents when the IC is AC coupled. The net effect is to make the IC nearly immune to imbalances in common mode source impedances over the audio frequency range. Putting an

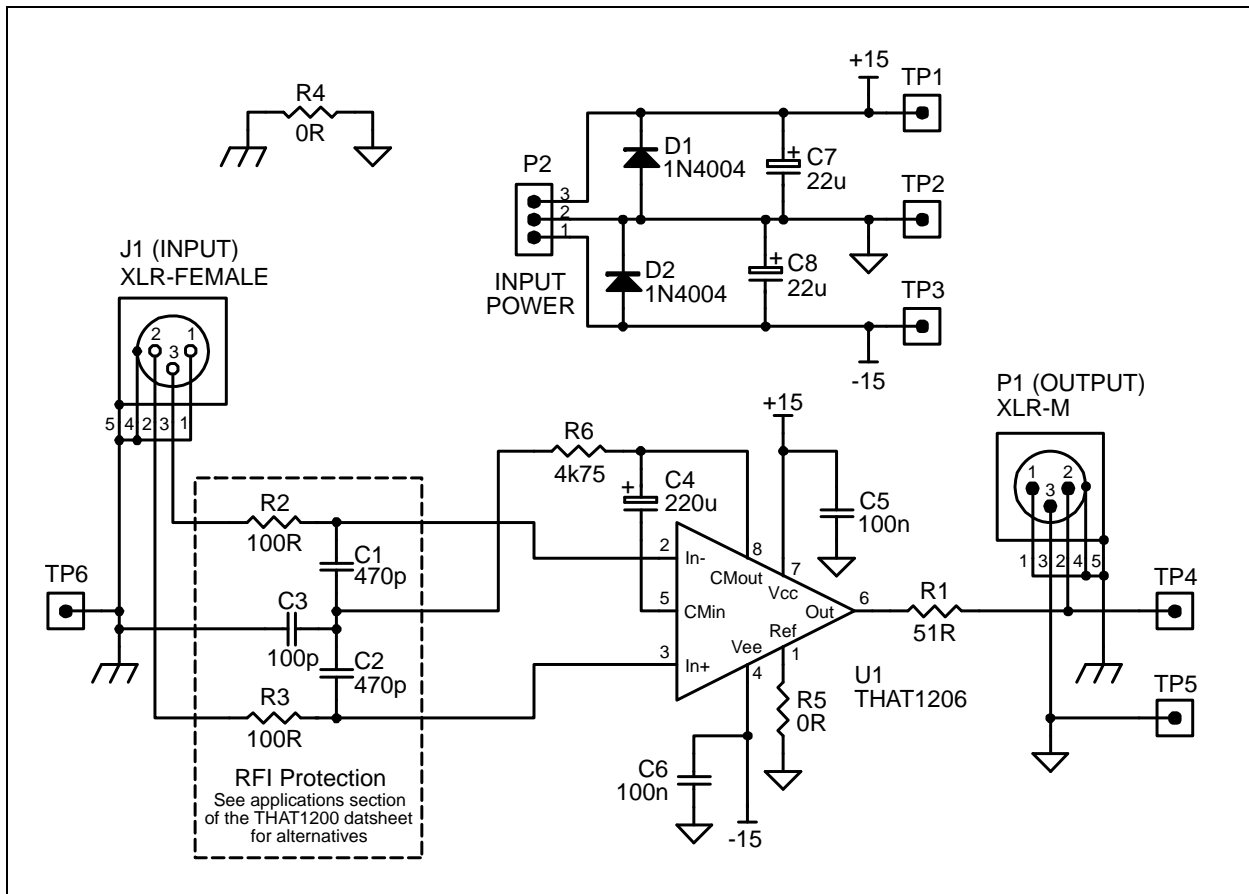

Figure 1. THAT1200 Demonstration System Schematic

unbalanced impedance in the location of R2 or R3 is a useful way to test this feature.

While C4 provides a means to bootstrap the IC's internal input impedance, it does nothing for external impedances (like the capacitors in the RFI protection). R6 improves this situation under many circumstances. At frequencies where the impedance of R6 is substantially less than that of C3 (and the THAT120x has sufficient GBW product), the common node of C1-3 and R6 will be driven by a replica of the common mode voltage found on pins 2 and 3. Since the common mode voltage cannot develop across C1 and C2, there cannot be any current associated with this common mode voltage, and as a

consequence, these components cannot load any potentially unbalanced common mode source impedance. Without this loading, there cannot be any common mode to differential conversion that might otherwise be associated with un-bootstrapped loads.

To ease prototyping of specific applications, spare circuit board area is perforated with plated through holes. This makes this board particularly useful for experimentation.

With a THAT1200 Demonstration System and standard audio cables, an engineer can begin evaluating the performance of the THAT1200 series of InGenius® line receivers in seconds, and try out new circuit ideas in minutes.

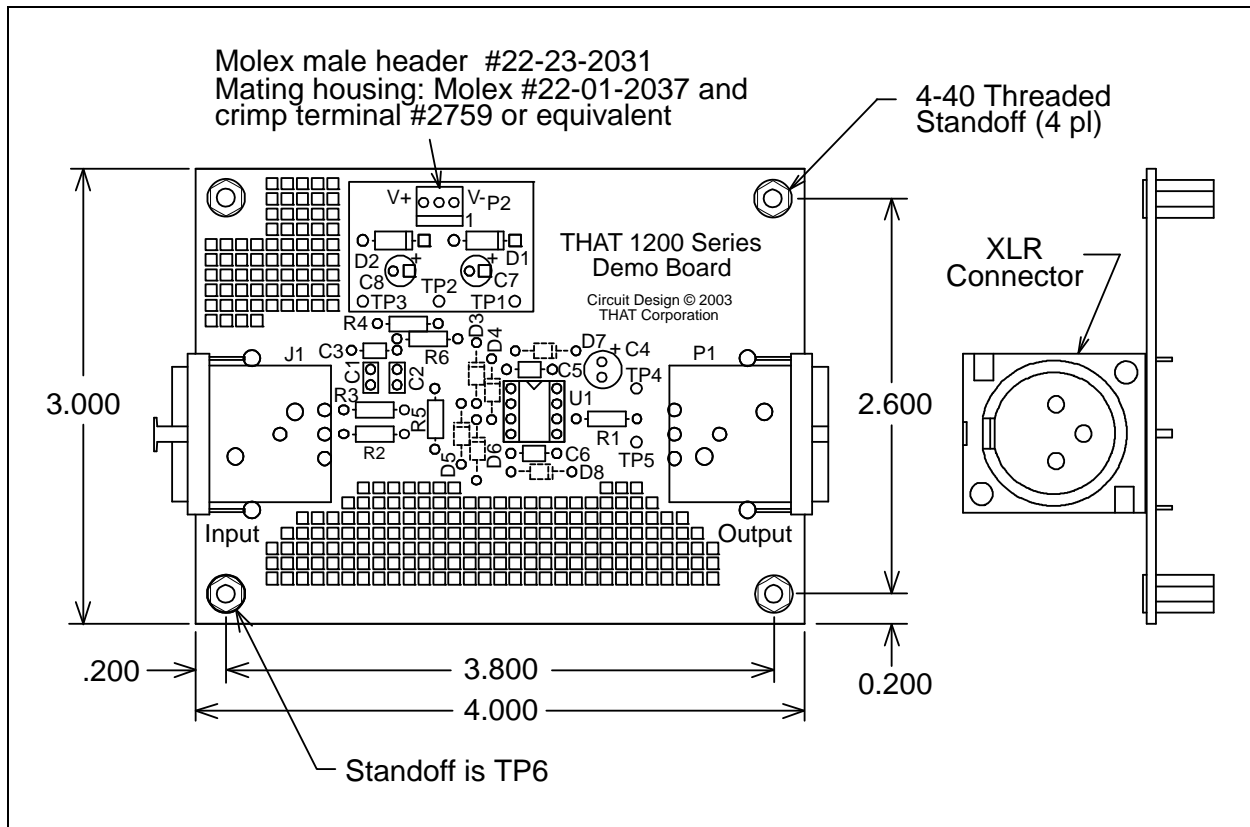

Figure 2. THAT1200 Demonstration System Outline Drawing

## Данный компонент на территории Российской Федерации

### Вы можете приобрести в компании MosChip.

Для оперативного оформления запроса Вам необходимо перейти по данной ссылке:

<http://moschip.ru/get-element>

Вы можете разместить у нас заказ для любого Вашего проекта, будь то серийное производство или разработка единичного прибора.

В нашем ассортименте представлены ведущие мировые производители активных и пассивных электронных компонентов.

Нашей специализацией является поставка электронной компонентной базы двойного назначения, продукции таких производителей как XILINX, Intel (ex.ALTERA), Vicor, Microchip, Texas Instruments, Analog Devices, Mini-Circuits, Amphenol, Glenair.

Сотрудничество с глобальными дистрибьюторами электронных компонентов, предоставляет возможность заказывать и получать с международных складов практически любой перечень компонентов в оптимальные для Вас сроки.

На всех этапах разработки и производства наши партнеры могут получить квалифицированную поддержку опытных инженеров.

Система менеджмента качества компании отвечает требованиям в соответствии с ГОСТ Р ИСО 9001, ГОСТ РВ 0015-002 и ЭС РД 009

### Офис по работе с юридическими лицами:

105318, г.Москва, ул.Щербаковская д.3, офис 1107, 1118, ДЦ «Щербаковский»

Телефон: +7 495 668-12-70 (многоканальный)

Факс: +7 495 668-12-70 (доб.304)

E-mail: [info@moschip.ru](mailto:info@moschip.ru)

Skype отдела продаж:

moschip.ru

moschip.ru\_4

moschip.ru\_6

moschip.ru\_9