

Ordering Information

Order Part Number	Top Marking		T _A	Package	
DIO5158XS8	DIO5158	Green	-40 to +85°C	EP-SOIC8	Tape & Reel, 2500
DIO5158XM8	DIO5158	Green	-40 to +85°C	EP-MSOP8	Tape & Reel, 2500
DIO5158CD10	D5158	Green	-40 to +85°C	DFN-10	Tape & Reel, 5000

Pin Assignment

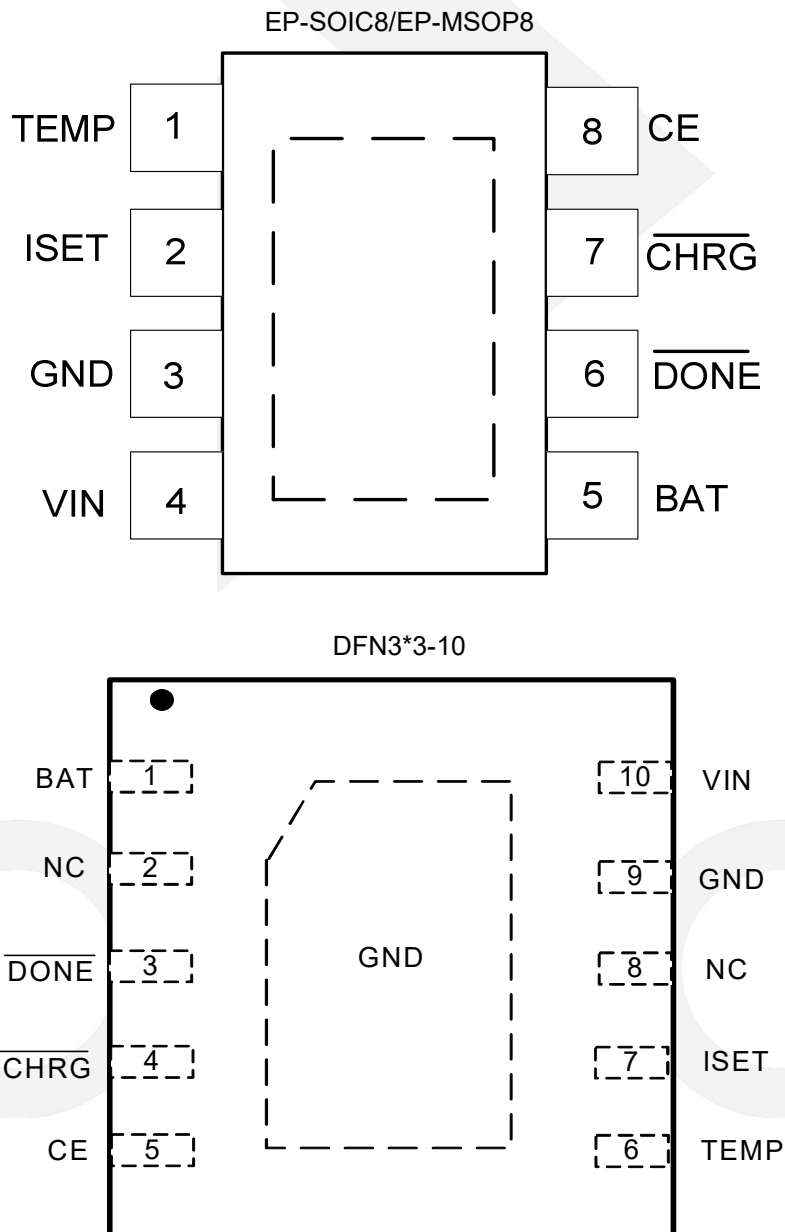

Figure 2 Pin Assignment

Block Diagram

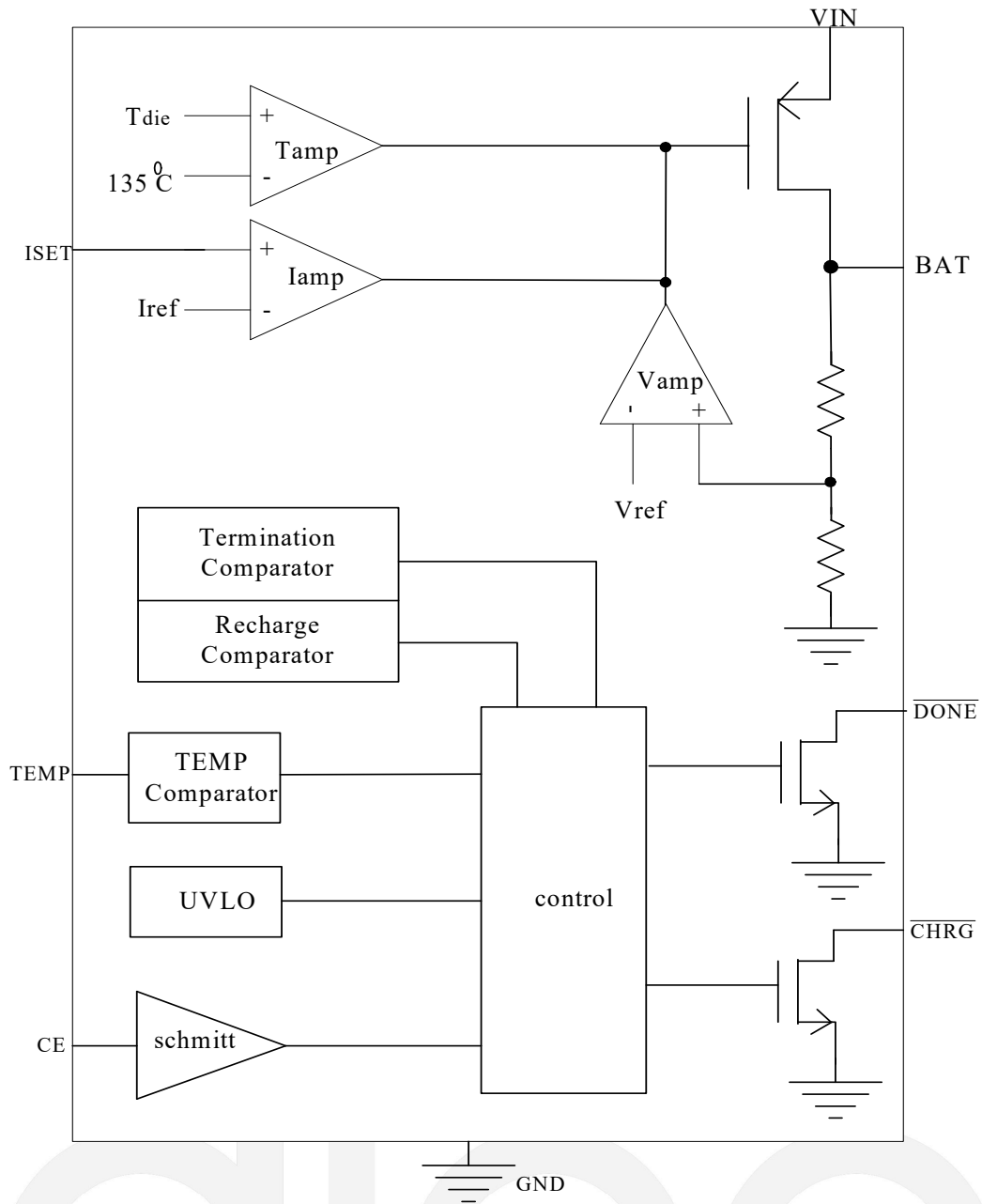

Figure 3 Block Diagram



DIO5158

Pin Descriptions

Pin No.	Name	Function Description
1	TEMP	Temperature sense Input. Connecting TEMP pin to NTC thermistor's output in Lithium ion battery pack. If TEMP pin's voltage is below 45% or above 80% of supply voltage V_{IN} , this means that battery's temperature is too high or too low, charging is suspended. If TEMP's voltage level is between 45% and 80% of supply voltage, charging will resume. The temperature sense function can be disabled by grounding the TEMP pin.
2	ISET	Constant Charge Current Setting and Charge Current Monitor Pin. The charge current is set by connecting a resistor R_{ISET} from this pin to GND. When in pre-charge mode, the ISET pin's voltage is regulated to 0.12V. When in constant charge current mode, the ISET pin's voltage is regulated to 1.205V. In all modes during charging, the voltage on ISET pin can be used to measure the charge current as follows: $I_{CH} = (V_{ISET} / R_{ISET}) * 1011$
3	GND	Ground Terminal.
4	VIN	Positive Input Supply Voltage. V_{IN} is the power supply to the internal circuit. When V_{IN} drops to within 10mv of the BAT pin voltage, DIO5158 enters low power sleep mode, dropping BAT pin's current to less than $3\mu A$.
5	BAT	Battery Connection Pin. Connect the positive terminal of the battery to BAT pin. BAT pin draws less than $3\mu A$ current in chip disable mode or in sleep mode. BAT pin provides charge current to the battery and provides regulation voltage of 4.2V.
6	\overline{DONE}	Charge termination Status Output. Open drain output. In charge termination status, \overline{DONE} is pulled low by an internal switch; Otherwise \overline{DONE} pin is in high impedance state.
7	\overline{CHRG}	Charge Status Output. Open drain Output. When the battery is being charged, the \overline{CHRG} pin is pulled low by an internal switch; otherwise \overline{CHRG} pin is in high impedance state.
8	CE	Chip Enable Input. A high input will put the device in the normal operating mode. Pulling the CE pin to low level will put the DIO5158 into disable mode. The CE pin can be driven by TTL or CMOS logic level.



DIO5158

Absolute Maximum Ratings

Stresses beyond those listed under “Absolute Maximum Rating” may cause permanent damage to the device. These are stress ratings only and functional operation of the device at these or any other condition beyond those indicated in the operational sections of the specifications is not implied. Exposure to absolute maximum rating conditions for extended periods may affect device reliability.

Parameter		Rating	Unit
All Terminal Voltage		-0.3 to 10	V
BAT Short Circuit Duration		Continuous	
Maximum Junction Temperature		150	°C
Storage Temperature Range		-65 to 150	°C
Junction Temperature		150	°C
Lead Temperature Range		300	°C
ESD	HBM, JEDEC: JESD22-A114	5.5	kV

Recommend Operating Conditions

The Recommended Operating Conditions table defines the conditions for actual device operation. Recommended Operating conditions are specified to ensure optimal performance to the datasheet specifications. DIOO does not Recommend exceeding them or designing to Absolute Maximum Ratings.

Parameter		Rating	Unit
Input Supply Voltage		3.8 to 6.5	V
Operating Temperature Range		-40 to 85	°C





DIO5158

1A Lithium Ion Battery Charger IC

Electrical Characteristics

V_{IN}=5V, T_A = -40 to 85°C, Typical values are measured at T_A = 25°C, unless otherwise specified.

Parameter	Symbol	Conditions	Min	Typ	Max	Unit
Input Supply Voltage	V _{IN}		3.8		6.5	V
Operating Current	I _{VIN}	CE=V _{IN} , No load at BAT pin	300	450	600	μA
		Chip disable mode, CE=GND		4		
Under-voltage Lockout	V _{UVLO}	V _{IN} rising		3.2	3.8	V
Regulation Voltage	V _{REG}	DIO5158	4.158	4.2	4.242	V
BAT pin Current	I _{BAT}	R _{ISET} =1.2K, constant current mode,	850	1000	1150	mA
		R _{ISET} =1.2K, V _{BAT} = 2.3V	75	100	125	
		V _{BAT} =V _{REG} , termination mode	1.75	3.5	7	μA
		CE=GND, disable mode			3	
		V _{IN} =0V, sleep mode			3	
Pre-charge Threshold						
Pre-charge Threshold	V _{PRE}	Voltage at BAT pin rising	2.83	2.93	3.03	V
Pre-charge Threshold Hysteresis	H _{PRE}			0.24		V
Charge Termination Threshold						
Charge Termination Threshold	V _{term}	Measure voltage at ISET pin	0.096	0.12	0.144	V
Recharge Threshold						
Recharge Threshold	V _{RECH}			V _{REG} - 0.15		V
Sleep Mode						
Sleep Mode Threshold	V _{SLP}	V _{IN} from high to low, measures the voltage (V _{IN} - V _{BAT})		10		mV
Sleep mode Release Threshold	V _{SLPR}	V _{IN} from low to high, measures the voltage (V _{IN} - V _{BAT})		60		mV
ISET Pin						
ISET Pin Voltage	V _{ISET}	Pre-charge mode		0.12		V
		Constant current mode		1.205		



DIO5158

1A Lithium Ion Battery Charger IC

TEMP PIN						
High Input Threshold	V_{HIGH}	The voltage at TEMP increases	77.5	80	82.5	%VIN
Low Input Threshold	V_{LOW}	The voltage at TEMP decreases	42.5	45	47.5	%VIN
TEMP input Current		TEMP to VIN or to GND			0.5	μA
CE Pin						
Logic Input Low	V_{CEL}	CE voltage falling, Chip disabled			0.7	V
Logic Input High	V_{CEH}	CE voltage rising, Chip enabled	2.2			V
CE Pin Current	I_{CEL}	CE=GND, VIN=6V	-1			μA
	I_{CEH}	CE=VIN=6V			1	
CHRG Pin						
CHRG Pin Sink Current	I_{CHRG}	$V_{CHRG}=0.3V$, charge mode		10		mA
CHRG Leakage Current		CE=GND, $V_{CHRG}=6V$			1	μA
DONE Pin						
DONE Pin Sink Current	I_{DONE}	$V_{DONE}=0.3V$, Fault status		10		mA
DONE Pin Leakage		CE=GND, $V_{FAULT}=6V$			1	μA

Specifications subject to change without notice.



Detailed Description

The DIO5158 is a linear battery charger IC designed primarily for charging single cell lithium-ion or lithium-polymer batteries. Featuring an internal P-channel power MOSFET, the charger uses a constant-current/constant-voltage to charge the batteries. Continuous charge current can be programmed up to 1A with an external resistor. No blocking diode or sense resistor is required. The open-drain output $\overline{\text{CHRG}}$ and $\overline{\text{DONE}}$ indicates the charger's status. The internal thermal regulation circuit reduces the programmed charge current if the die temperature attempts to rise above a preset value of approximately 135°C. This feature protects the DIO5158 from excessive temperature, and allows the user to push the limits of the power handling capability of a given circuit board without risk of damaging the DIO5158 or the external components. Another benefit of adopting thermal regulation is that charge current can be set according to typical, not worst-case, ambient temperatures for a given application with the assurance that the charger will automatically reduce the current in worst-case conditions.

The charge cycle begins when the voltage at the VIN pin rises above both the UVLO level and the battery voltage, a current set resistor is connected from the ISET pin to ground, and the CE pin is pulled above the chip enable threshold. The $\overline{\text{CHRG}}$ pin outputs a logic low to indicate that the charge cycle is ongoing. At the beginning of the charge cycle, if the battery voltage is below 2.93V, the charger is in pre-charge mode to bring the cell voltage up to a safe level for charging. The charger goes into the fast charge constant-current mode once the voltage on the BAT pin rises above 2.93V. In constant current mode, the charge current is set by R_{ISET} . When the battery approaches the regulation voltage, the charge current begins to decrease as the DIO5158 enters the constant-voltage mode. When the current drops to charge termination threshold, the charge cycle is terminated, and $\overline{\text{CHRG}}$ pin assumes a high impedance state to indicate that the charge cycle is terminated. The charge termination threshold is 10% of the current in constant current mode. To restart the charge cycle, remove the input voltage and reapply it, or momentarily force CE pin to 0V. The charge cycle can also be automatically restarted if the BAT pin voltage falls below the recharge threshold. The on-chip reference voltage, error amplifier and the resistor divider provide regulation voltage with 1% accuracy which can meet the requirement of lithium-ion and lithium polymer batteries. When the input voltage is not present, the charger goes into a sleep mode, dropping battery drain current to less than 3 μ A. This greatly reduces the current drain on the battery and increases the standby time. The charger can be shut down by forcing the CE pin to GND.

The charging profile is shown in the following figure.



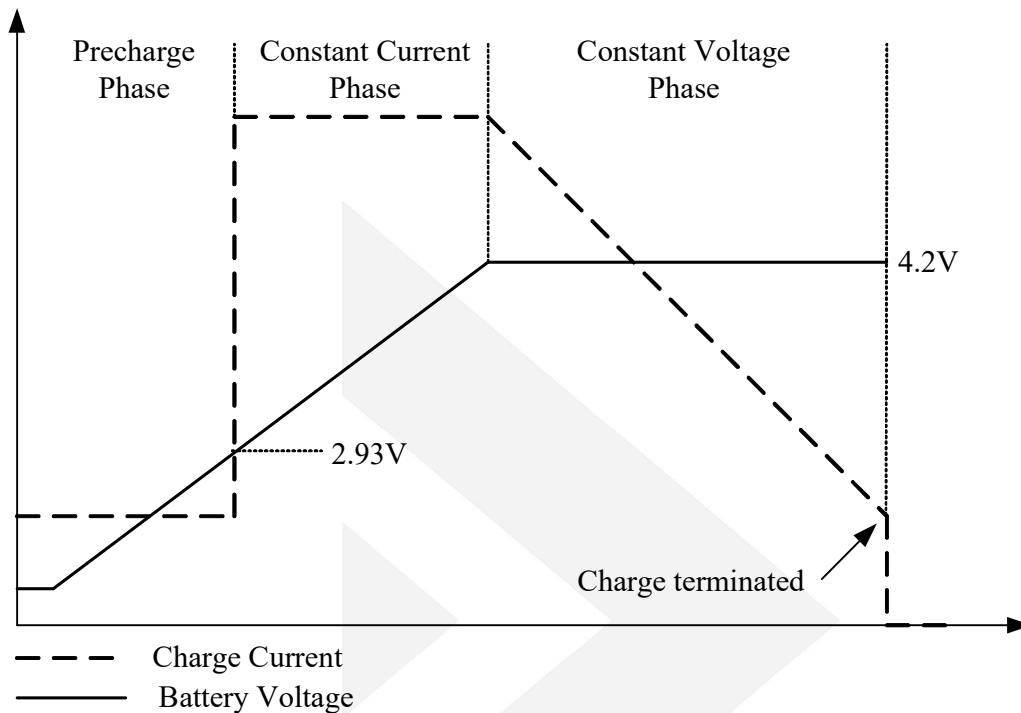

Figure 4 Charging Profile

Application Information

Under-voltage Lockout (UVLO)

An internal under-voltage lockout circuit monitors the input voltage and keeps the charger in shutdown mode until V_{IN} rises above the under-voltage lockout voltage.

Sleep mode

There is an on-chip sleep comparator. The comparator keeps the DIO5158 in sleep mode if V_{IN} falls below sleep mode threshold ($V_{BAT}+10mV$). Once in sleep mode, the DIO5158 will not come out of sleep mode until V_{IN} rises 60mV above the battery voltage.

Pre-charge mode

At the beginning of a charge cycle, if the battery voltage is below 2.93V, the DIO5158 goes into pre-charge mode, and the charge current is 10% of fast charge current in constant current mode.

Chip Enable/Disable

The DIO5158 can be disabled by pulling the CE pin to less than 0.7V. For normal operation, pull the CE pin above 2.2V. Applying a voltage between 0.7V to 2.2V to this pin may cause larger operating current, and the DIO5158 may be in uncertain state. When the chip is disabled, the internal linear regulator and the power MOSFET are turned off.

Programming Charge Current

The formula for the battery charge current in constant current mode is:

$$I_{CH} = 1218V / R_{ISET}$$

Where:

I_{CH} is the charge current in ampere

R_{ISET} is the total resistance from the ISET pin to ground in ohm

For example, if 500mA charge current is required, calculate:

$$R_{ISET} = 1218V/0.5A = 2.436K\Omega$$

For best stability over temperature and time, 1% metal film resistors are recommended. If the charger is in constant-temperature or constant voltage mode, the charge current can be monitored by measuring the ISET pin voltage, and the charge current is calculated as the following equation:

$$I_{CH} = (V_{ISET} / R_{ISET}) \times 1011$$

Battery Temperature Monitoring

To prevent the damage caused by the very high or very low temperature done to the battery pack, the DIO5158 continuously senses battery pack temperature by measuring the voltage at TEMP pin determined by the voltage divider circuit and the battery's internal NTC thermistor as shown in Figure 1.

The DIO5158 compares the voltage at TEMP pin (V_{TEMP}) against its internal V_{LOW} and V_{HIGH} thresholds to determine if charging is allowed. In DIO5158, V_{LOW} is fixed at (45%*VIN), while V_{HIGH} is fixed at (80%*VIN). If $V_{TEMP} < V_{LOW}$ or $V_{TEMP} > V_{HIGH}$, it indicates that the battery temperature is too high or too low and the charge cycle is suspended. If V_{TEMP} is between V_{LOW} and V_{HIGH} , the charge cycle resumes. The battery temperature sense function can be disabled by connecting TEMP pin to GND.

Selecting R1 and R2

The values of R1 and R2 in the application circuit can be determined according to the assumed temperature monitor range and thermistor's values. The Follows is an example:

Assume temperature monitor range is $T_L \sim T_H$ ($T_L < T_H$); the thermistor in battery has negative temperature coefficient (NTC), R_{TL} is thermistor's resistance at T_L , R_{TH} is the resistance at T_H , so $R_{TL} > R_{TH}$, then at temperature T_L , the voltage at TEMP pin is:

$$V_{TEMPL} = \frac{R2 // R_{TL}}{R1 + R2 // R_{TL}} \times V_{IN}$$

At temperature T_H , the voltage at TEMP pin is:

$$V_{TEMPH} = \frac{R2 // R_{TH}}{R1 + R2 // R_{TH}} \times V_{IN}$$

We know, $V_{TEMPL} = V_{HIGH} = k_2 * VIN$ ($k_2 = 0.8$)

$$V_{TEMPH} = V_{LOW} = k_1 * VIN \quad (k_1 = 0.45)$$

Then we can have:

$$R1 = \frac{R_{TL} \times R_{TH} \times (k_2 - k_1)}{(R_{TL} - R_{TH})k_1k_2}$$

$$R2 = \frac{R_{TL} \times R_{TH} \times (k_2 - k_1)}{R_{TL}(k_1 - k_1k_2) - R_{TH}(k_2 - k_1k_2)}$$

Likewise, for positive temperature coefficient thermistor in battery, we have $R_{TH} > R_{TL}$ and we can calculate:

$$R1 = \frac{R_{TL} \times R_{TH} \times (k_2 - k_1)}{(R_{TH} - R_{TL})k_1k_2}$$

$$R2 = \frac{R_{TL} \times R_{TH} \times (k_2 - k_1)}{R_{TH}(k_1 - k_1k_2) - R_{TL}(k_2 - k_1k_2)}$$

We can conclude that temperature monitor range is independent of power supply voltage V_{IN} and it only depends on $R1$, $R2$, R_{TL} and R_{TH} . The values of R_{TH} and R_{TL} can be found in related battery handbook or deduced from testing data.

In actual application, if only one terminal temperature is concerned (normally protecting over-heating), there is no need to use $R2$ but $R1$. It becomes very simple to calculate $R1$ in this case.

Recharge

After a charge cycle has terminated, if the battery voltage drops below the recharge threshold of 4.05V, a new charge cycle will begin automatically.

Constant-Current/Constant-Voltage/Constant-Temperature

The DIO5158 use a unique architecture to charge a battery in a constant-current, constant-voltage, constant temperature fashion as shown in Figure 3. Amplifiers I_{amp} , V_{amp} , and T_{amp} are used in three separate feedback loops to force the charger into constant-current, constant-voltage, or constant-temperature mode, respectively. In constant current mode the charge current delivered to the battery equal to $1218V/R_{ISET}$. If the power dissipation of the DIO5158 results in the junction temperature approaching $135^{\circ}C$, the amplifier T_{amp} will begin decreasing the charge current to limit the die temperature to approximately $135^{\circ}C$. As the battery voltage rises, the DIO5158 either returns to constant-current mode or it enters constant voltage mode straight from constant-temperature mode.

Open-Drain Status Outputs

The DIO5158 have 2 open-drain status outputs: \overline{CHRG} and \overline{DONE} . \overline{CHRG} is pulled low when the charger is in charging status, otherwise \overline{CHRG} becomes high impedance. \overline{DONE} is pulled low in charge termination status, otherwise \overline{DONE} becomes high impedance.

When the battery is not present, the charger charges the output capacitor to the regulation voltage quickly, then the BAT pin's voltage decays slowly to recharge threshold because of low leakage current at BAT pin, which results in a 150mV ripple waveform at BAT pin, and both \overline{CHRG} pin and \overline{DONE} pin output high impedance. The open drain status output that is not used should be tied to ground.

VIN Bypass Capacitor

Many types of capacitors can be used for input bypassing (C1 in Figure 1), Generally, a 1 μ F ceramic capacitor, placed in close proximity to VIN and GND pins, works well. In some applications depending on the power supply characteristics and cable length, it may be necessary to increase the capacitor's value.

Stability

Typically a 4.7 μ F to 10 μ F capacitor (C2 in Figure 1) from BAT pin to GND is required to stabilize the feedback loop.

In constant current mode, the stability is also affected by the impedance at the ISET pin. With no additional capacitance on the ISET pin, the loop is stable with current set resistors values as high as 50K Ω . However, additional capacitance on ISET pin reduces the maximum allowed current set resistor. The pole frequency at ISET pin should be kept above 200KHz. Therefore, if ISET pin is loaded with a capacitance C, the following equation should be used to calculate the maximum resistance value for R_{ISET}:

$$R_{ISET} < 1/(6.28 \times 2 \times 10^5 \times C).$$

Board Layout Considerations

1. R_{ISET} at ISET pin should be as close to DIO5158 as possible, also the parasitic capacitance at ISET pin should be kept as small as possible.
2. The capacitance at VIN pin and BAT pin should be as close to DIO5158 as possible.
3. During charging, DIO5158's temperature may be high, the NTC thermistor should be placed far enough to DIO5158, so that the thermistor can reflect the battery's temperature correctly.
4. It is very important to use a good thermal PC board layout to maximize charging current. The thermal path for the heat generated by the IC is from the die to the copper lead frame through the package lead (especially the ground lead) to the PC board copper, the PC board copper is the heat sink. The footprint copper pads should be as wide as possible and expand out to larger copper areas to spread and dissipate the heat to the surrounding ambient. Feed through vias to inner or backside copper layers are also useful in improving the overall thermal performance of the charger. Other heat sources on the board, not related to the charger, must also be considered when designing a PC board layout because they will affect overall temperature rise and the maximum charge current.

The ability to deliver maximum charge current under all conditions requires that the exposed metal pad on the back side of the DIO5158 package be soldered to the PC board ground. Failure to make the thermal contact between the exposed pad on the backside of the package and the copper board will result in larger thermal resistance.

Physical Dimensions: EP-SOIC8

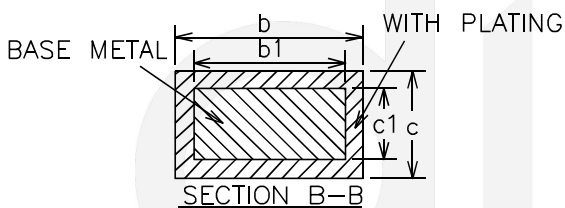
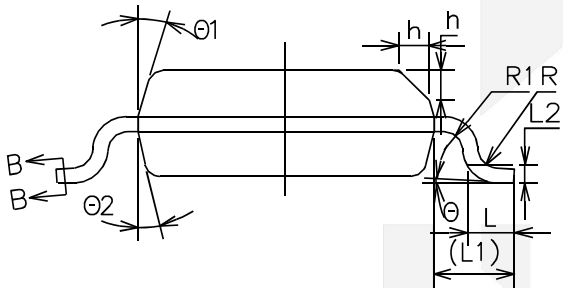
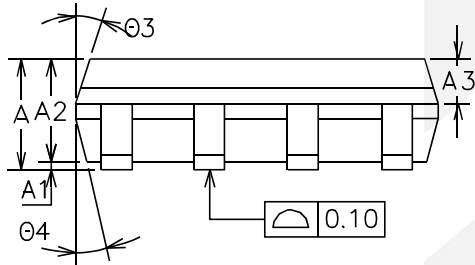
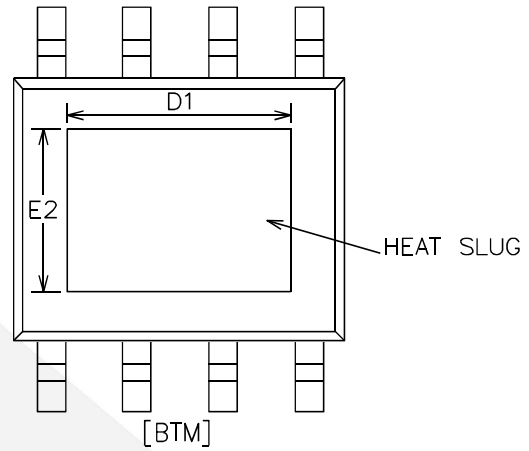
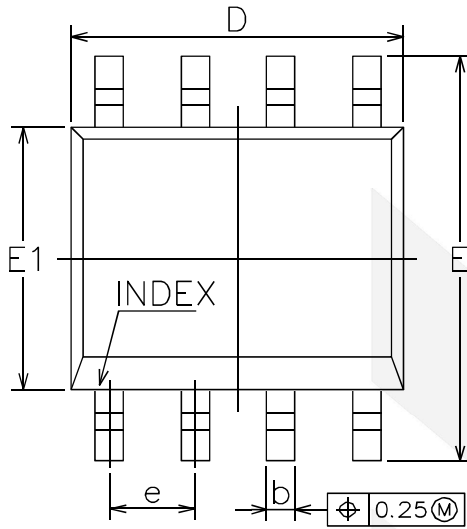

COMMON DIMENSIONS (MM)				
(Units of Measure = Mill meter)				
SYMBOL	MIN.	NOM.	MAX.	
A	1.35	1.55	1.70	
A1	0	0.10	0.15	
A2	1.25	1.40	1.65	
A3	0.50	0.60	0.70	
b	0.38		0.51	
b1	0.37	0.42	0.47	
c	0.17		0.25	
c1	0.17	0.20	0.23	
D	4.80	4.90	5.00	
D1	Option 1	3.10	3.30	3.50
	Option 2	2.09	2.29	2.49
E	5.80	6.00	6.20	
E1	3.80	3.90	4.00	
E2	Option 1	2.20	2.40	2.60
	Option 2	2.09	2.29	2.49
e	1.17	1.27	1.37	
L	0.45	0.60	0.80	
L1	1.04REF			
L2	0.25BSC			
R	0.07			
R1	0.07			
h	0.30	0.40	0.50	
theta	0°		8°	
theta1	15°	17°	19°	
theta2	11°	13°	15°	
theta3	15°	17°	19°	
theta4	11°	13°	15°	

Physical Dimensions: EP-MSOP8

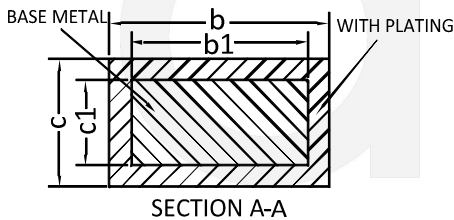
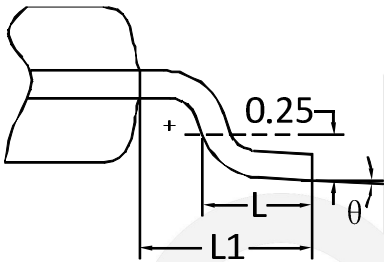
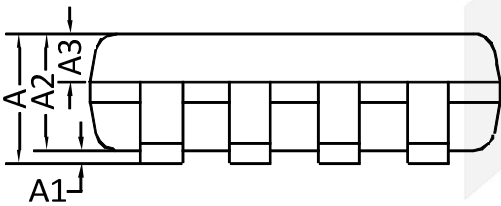
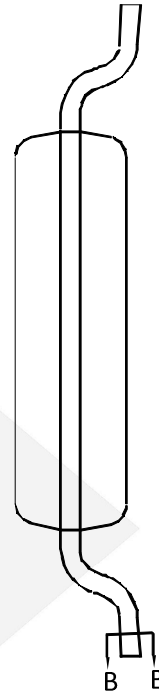
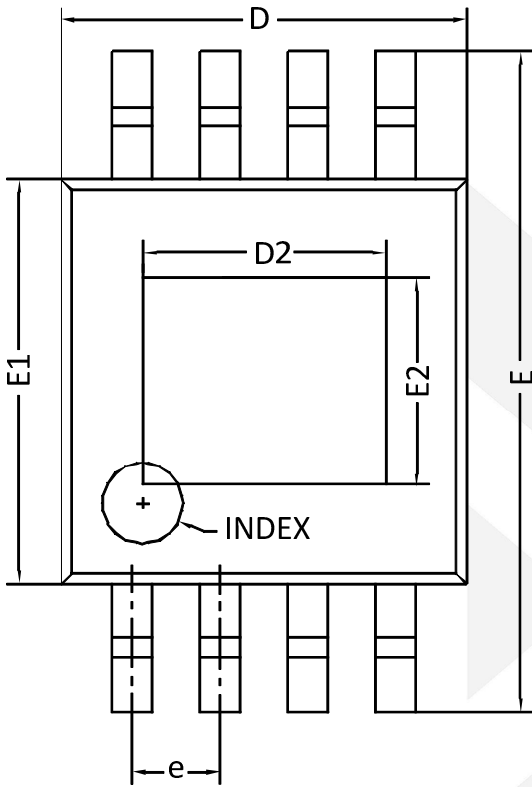

COMMON DIMENSIONS (UNITS OF MEASURE=MILLIMETER)			
Symbol	MIN	NOM	MAX
A	-	-	1.10
A1	0.05	-	0.15
A2	0.75	0.85	0.95
A3	0.30	0.35	0.40
b	0.29	-	0.38
b1	0.28	0.30	0.33
c	0.15	-	0.20
c1	0.14	0.152	0.16
D	2.90	3.00	3.10
D2	1.80 REF		
E	4.70	4.90	5.10
E1	2.90	3.00	3.10
E2	1.55 REF		
e	0.65 BSC		
L	0.40	-	0.70
L1	0.95 BSC		
θ	0°	-	8°

Physical Dimensions: DFN3*3-10

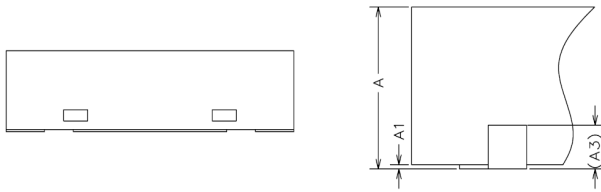
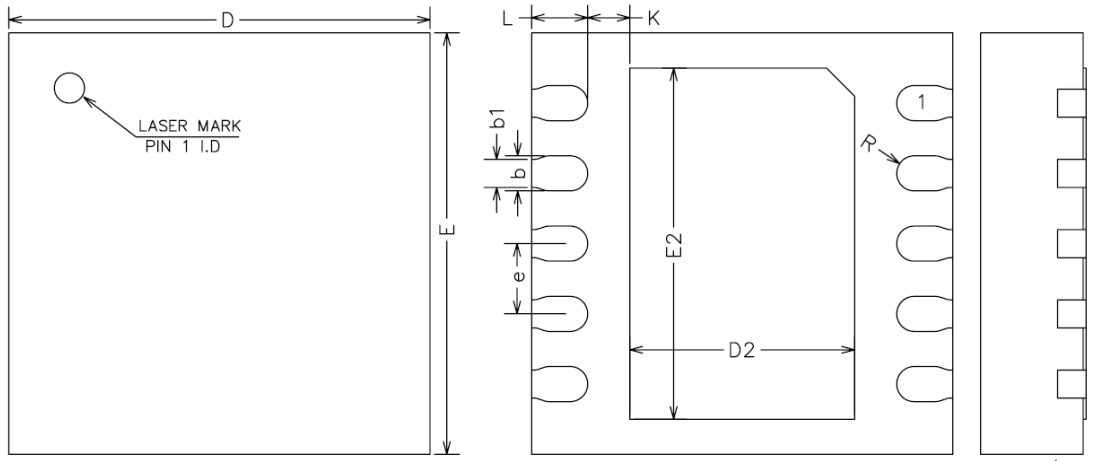

COMMON DIMENSIONS (UNITS OF MEASURE=MILLIMETER)			
Symbol	MIN	NOM	MAX
A	0.70	0.75	0.80
A1	0	0.02	0.05
A3	0.20REF		
b	0.20	0.25	0.30
b1	0.20REF		
D	2.90	3.00	3.10
E	2.90	3.00	3.10
D2	1.50	1.60	1.70
E2	2.40	2.50	2.60
e	0.40	0.50	0.60
K	0.20	-	-
L	0.30	0.40	0.50
R	0.13	-	-

CONTACT US

Dioo is a professional design and sales corporation for high-quality and performance analog semiconductors. The company focuses on industry markets, such as, cell phone, handheld products, laptop, and medical equipment and so on. Dioo's product families include analog signal processing and amplifying, LED drivers and charger IC. Go to <http://www.dioo.com> for a complete list of Dioo product families.

For additional product information, or full datasheet, please contact with our Sales Department or Representatives.

A large, light gray watermark of the Dioo logo is centered on the page. It consists of a stylized arrow pointing right, followed by the word "dioo" in a lowercase, sans-serif font.

Данный компонент на территории Российской Федерации

Вы можете приобрести в компании MosChip.

Для оперативного оформления запроса Вам необходимо перейти по данной ссылке:

<http://moschip.ru/get-element>

Вы можете разместить у нас заказ для любого Вашего проекта, будь то серийное производство или разработка единичного прибора.

В нашем ассортименте представлены ведущие мировые производители активных и пассивных электронных компонентов.

Нашей специализацией является поставка электронной компонентной базы двойного назначения, продукции таких производителей как XILINX, Intel (ex.ALTERA), Vicor, Microchip, Texas Instruments, Analog Devices, Mini-Circuits, Amphenol, Glenair.

Сотрудничество с глобальными дистрибьюторами электронных компонентов, предоставляет возможность заказывать и получать с международных складов практически любой перечень компонентов в оптимальные для Вас сроки.

На всех этапах разработки и производства наши партнеры могут получить квалифицированную поддержку опытных инженеров.

Система менеджмента качества компании отвечает требованиям в соответствии с ГОСТ Р ИСО 9001, ГОСТ РВ 0015-002 и ЭС РД 009

Офис по работе с юридическими лицами:

105318, г.Москва, ул.Щербаковская д.3, офис 1107, 1118, ДЦ «Щербаковский»

Телефон: +7 495 668-12-70 (многоканальный)

Факс: +7 495 668-12-70 (доб.304)

E-mail: info@moschip.ru

Skype отдела продаж:

moschip.ru

moschip.ru_4

moschip.ru_6

moschip.ru_9