

# General Specifications

## Electrical Capacity (Resistive Load)

<b>Power Level (silver):</b>	3VA maximum @ 28V DC maximum (Applicable Range 10mA ~ 125mA @ 0.1V ~ 28V)
<b>Logic Level (gold):</b>	0.4VA maximum @ 28V AC/DC maximum (Applicable Range 0.1mA ~ 0.1A @ 20mV ~ 28V)
	Note: See Supplement for further explanation of operating range.

## Other Ratings

<b>Contact Resistance:</b>	100 milliohms maximum
<b>Insulation Resistance:</b>	100 megohms minimum @ 100V DC
<b>Dielectric Strength:</b>	250V AC minimum for 1 minute minimum between contacts & between contacts & case
<b>Mechanical Life:</b>	500,000 operations minimum
<b>Electrical Life:</b>	500,000 operations minimum
<b>Nominal Operating Force:</b>	1.60N
<b>Total Travel:</b>	.008" (0.2mm)

## Materials & Finishes

<b>Actuator:</b>	Glass fiber reinforced polyamide (UL94V-0)
<b>Case:</b>	Stainless steel
<b>Base:</b>	Glass fiber reinforced polyamide (UL94V-0)
<b>Movable Contacts:</b>	Stainless steel with silver or gold plating
<b>Stationary Contacts:</b>	Brass with silver or gold plating
<b>Terminals:</b>	Brass with silver or gold plating

## Environmental Data

<b>Operating Temperature Range:</b>	-20°C through +70°C (-4°F through +158°F)
<b>Humidity:</b>	90 ~ 95% humidity for 240 hours @ 40°C (104°F)
<b>Vibration:</b>	10 ~ 55Hz with peak-to-peak amplitude of 1.5mm traversing the frequency range & returning in 1 minute; 3 right angled directions for 2 hours
<b>Shock:</b>	100G (981m/s <sup>2</sup> ) acceleration (tested in 6 right angled directions, with 5 shocks in each direction)

## PCB Processing

<b>Soldering:</b>	Wave Soldering Recommended. See Profile A in Supplement section. Manual Soldering: See Profile A in Supplement section.
<b>Cleaning:</b>	These devices are not process sealed. Hand clean locally using alcohol based solution.

## Standards & Certifications

<b>Flammability Standards:</b>	UL94V-0 actuator and base These switches are designed for use in a low-voltage, low-current circuit. When used as intended, the results do not produce hazardous energy.
--------------------------------	--

# Distinctive Characteristics

.244" (6.2mm) square body allows compact mounting.

Heat resistant resin body meets lead-free solder processing requirements and UL flammability rating of 94V-0.

Stick-tube packaging allows rapid automated placement of devices.

Gold plated contacts available for very low voltage/current applications offer advantages of little or no oxidization or sulfurization and stable contact resistance.

Crimped terminals provide a spring type action which ensures secure mounting and prevents dislodging during automated soldering.

Insert molded terminals lock out flux, solvents, and other contaminants and allow automated soldering.

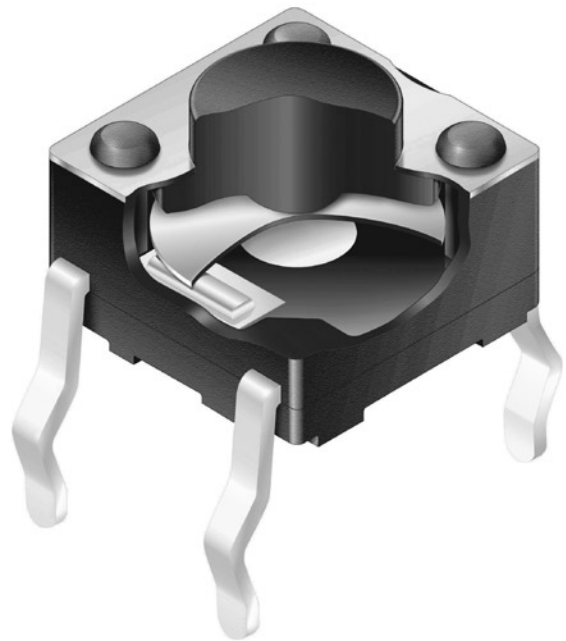

Actual Size

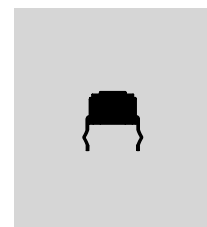

### TYPICAL SWITCH ORDERING EXAMPLE

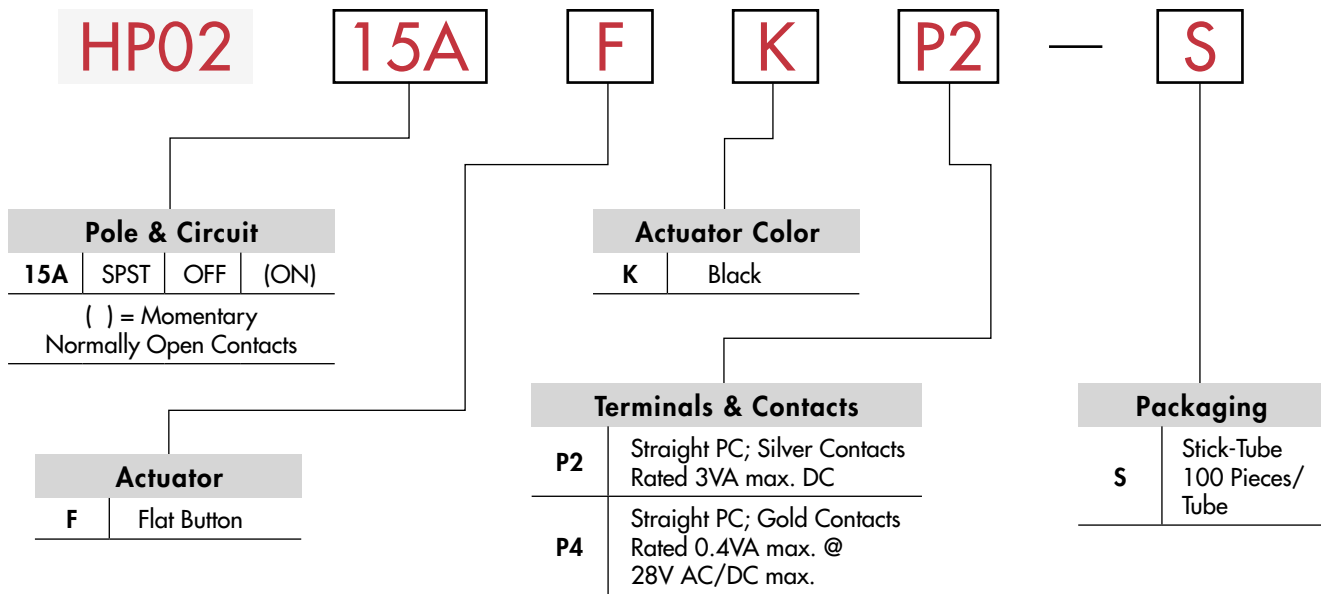

### DESCRIPTION FOR TYPICAL ORDERING EXAMPLE

#### HP0215AFKP2-S

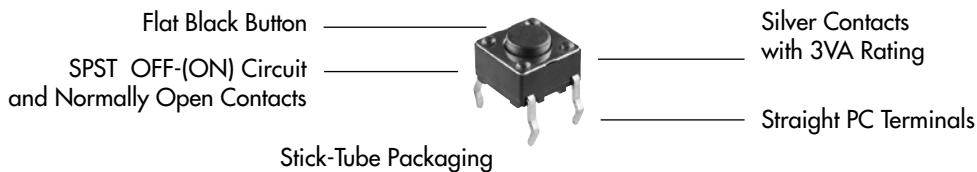

### POLE & CIRCUIT

		Actuator Position ( ) = Momentary		Switch Throw & Schematic	Note: Terminal numbers are not actually on the switch.
Pole	Model	Normal	Down	SPST	
SP	HP0215A	OFF	(ON)		

### TYPICAL SWITCH DIMENSIONS

#### Straight PC



HP0215AFKP2

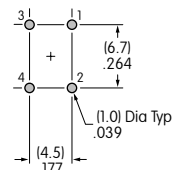
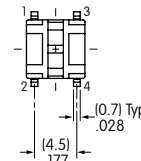
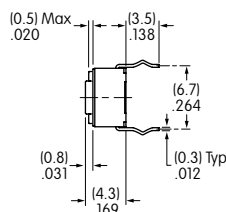
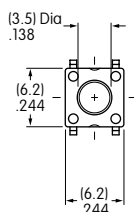

PACKAGING

S

Stick-Tube

Switches must be ordered in 100-piece increments.

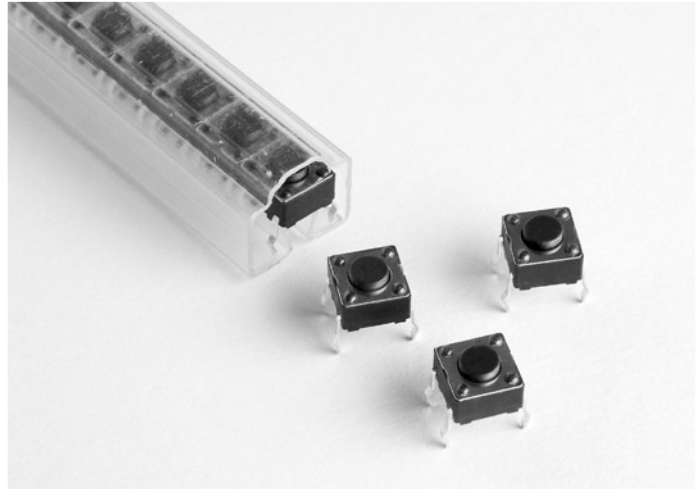

Stick-Tube Dimensions

Each stick-tube contains 100 switches.

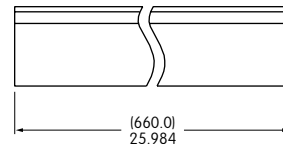
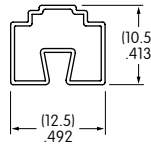

KEYBOARD MATRIX

Common Bus Matrix

These single pole, single throw switches can be used in a keyboard matrix and, using strapped terminals, achieve a common bus electrical configuration on a single-sided PC board.

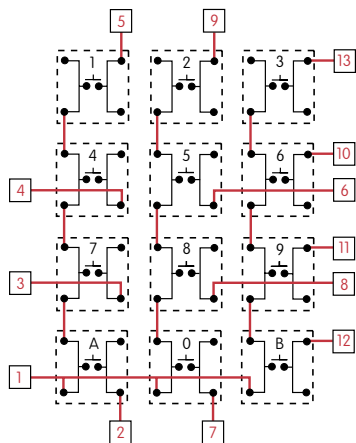

		PC Terminations												
		1	2	3	4	5	6	7	8	9	10	11	12	13
Keys (Switches)	1													
	2													
	3													
	4													
	5													
	6													
	7													
	8													
	9													
	0													
	A													
	B													

● = ON

X-Y Matrix

These single pole, single throw switches can be arranged on a single-sided PC board matrix with strapped terminals to achieve an X-Y type electrical interconnection.

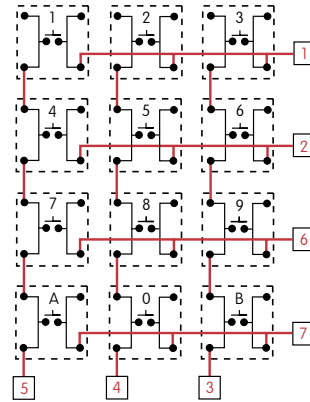

		PC Terminations						
		1	2	3	4	5	6	7
Keys (Switches)	1							
	2							
	3							
	4							
	5							
	6							
	7							

● = ON

Red = PCB Trace    Black = Switch Circuit

## Данный компонент на территории Российской Федерации

### Вы можете приобрести в компании MosChip.

Для оперативного оформления запроса Вам необходимо перейти по данной ссылке:

<http://moschip.ru/get-element>

Вы можете разместить у нас заказ для любого Вашего проекта, будь то серийное производство или разработка единичного прибора.

В нашем ассортименте представлены ведущие мировые производители активных и пассивных электронных компонентов.

Нашей специализацией является поставка электронной компонентной базы двойного назначения, продукции таких производителей как XILINX, Intel (ex.ALTERA), Vicor, Microchip, Texas Instruments, Analog Devices, Mini-Circuits, Amphenol, Glenair.

Сотрудничество с глобальными дистрибьюторами электронных компонентов, предоставляет возможность заказывать и получать с международных складов практически любой перечень компонентов в оптимальные для Вас сроки.

На всех этапах разработки и производства наши партнеры могут получить квалифицированную поддержку опытных инженеров.

Система менеджмента качества компании отвечает требованиям в соответствии с ГОСТ Р ИСО 9001, ГОСТ РВ 0015-002 и ЭС РД 009

### Офис по работе с юридическими лицами:

105318, г.Москва, ул.Щербаковская д.3, офис 1107, 1118, ДЦ «Щербаковский»

Телефон: +7 495 668-12-70 (многоканальный)

Факс: +7 495 668-12-70 (доб.304)

E-mail: [info@moschip.ru](mailto:info@moschip.ru)

Skype отдела продаж:

moschip.ru

moschip.ru\_4

moschip.ru\_6

moschip.ru\_9