

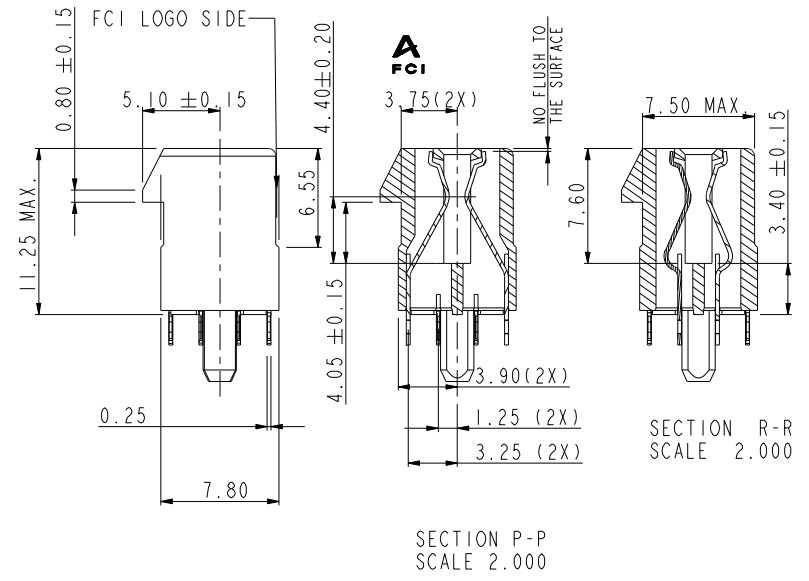

Copyright FCI.

REV F - 2006-04-17

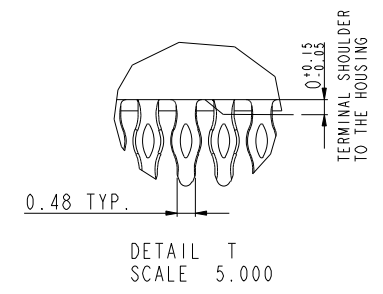
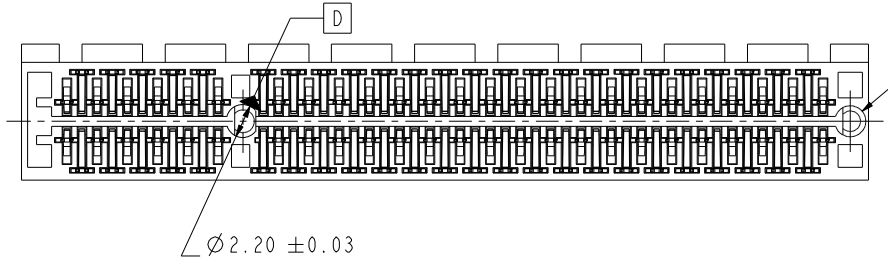
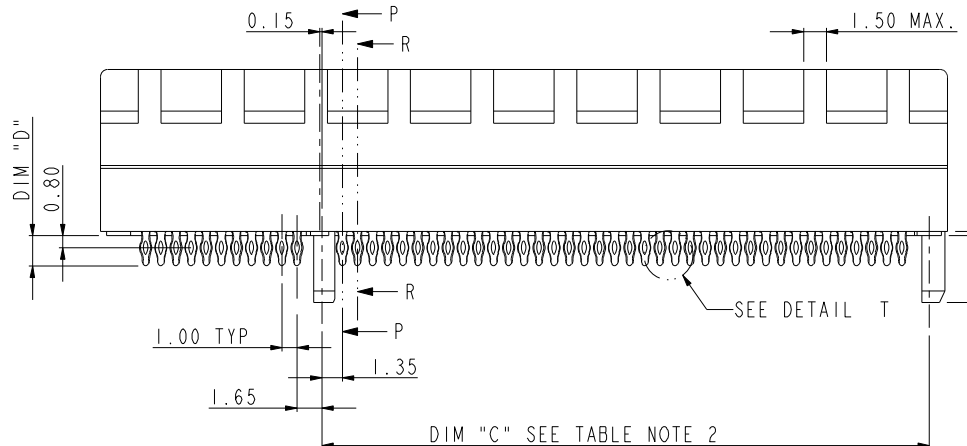
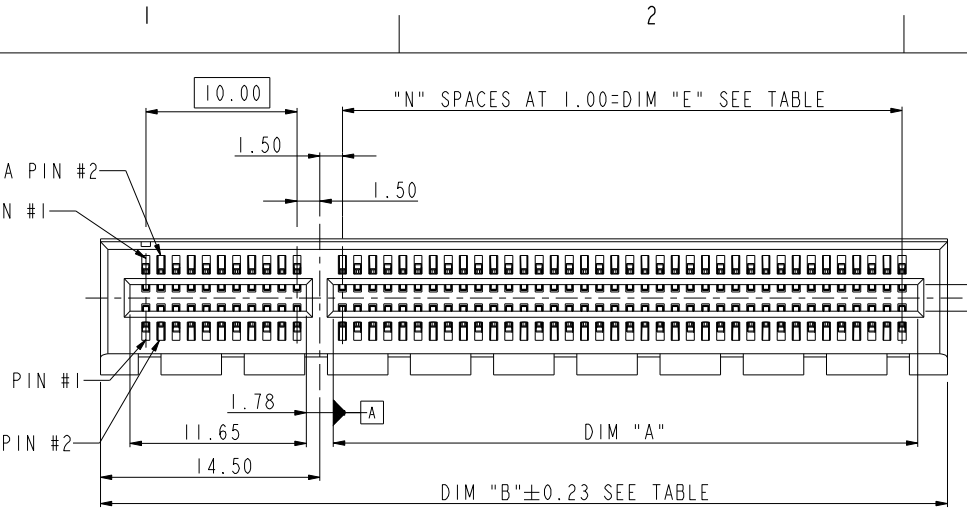

tolerance unless otherwise specified	
linear	.X ± .3 .XX ± .2 .XXX ± .1
angles	0° ± 2°

www.fciconnect.com			✓	tolerance	projection	MM
Dr	MAGGIE WU	07/23/04	Product family		size	Scale
Eng	R Y LIU	07/23/04	Spec ref		A4	1.000
Chr	PAUL WANG	07/23/04	Material		ECN	DG09-0045
Appr	JOSEPH HSIA	07/23/04				
FCI PCI EXPRESS PRESS-FIT ASS'Y					dwg no	10039755
catalog no					* CUSTOMER DRAWING	sheet 1 of 6
						Rev. K

rev	ecn no	dr	date
H	DG06-0161	P M	04/11/06
J	DG06-0249	P M	06/24/06
K	DG09-0045	B L	02/23/09
E	T05-0224	M W	09/27/05
F	T05-0243	M W	10/27/05
G	T05-0257	M W	11/08/05

PDM: Rev:K

STATUS:Released

Printed: Mar 15, 2011



Copyright FCI.

PIN #A1 IDENTIFIED BY SQUARE ANNULAR RING



RECOMMENDED FOOTPRINT



tolerance unless otherwise specified	
linear	.X ± .3 .XX ± .2 .XXX ± .1
angles	0° ± 2°

www.fciconnect.com			✓ tolerance	projection	MM
Dr	MAGGIE WU	07/23/04	Product family	size	A4
Eng	R Y LIU	07/23/04	Spec ref	Scale	1.000
Chr	PAUL WANG	07/23/04	Material	ECN	DG09-0045
Appr	JOSEPH HSIA	07/23/04			
FCI PCI EXPRESS PRESS-FIT ASS'Y			dwg no	10039755	Rev. K
catalog no			* CUSTOMER DRAWING sheet 2 of 6		

A

B

C

D

A

B

C

D



← I/O PANEL DIRECTION
PRIMARY (COMPONENT) SIDE



DETAIL F
SCALE 5.000

# POS REF.	N	DIM "G"	"F"
98	37	39.15	B48
164	70	72.15	B81

tolerance unless otherwise specified	
linear	.X ± .3 .XX ± .2 .XXX ± .1
angles	0° ± 2°

www.fciconnect.com			tolerance	projection	MM
Dr	MAGGIE WU	07/23/04	Product family	size	A4
Eng	R Y LIU	07/23/04	Spec ref	Scale	1.000
Chr	PAUL WANG	07/23/04	Material	ECN	DG09-0045
Appr	JOSEPH HSIA	07/23/04			
FCI PCI EXPRESS PRESS-FIT ASS'Y			dwg no	10039755	Rev. K
catalog no			* CUSTOMER DRAWING sheet 3 of 6		



Copyright FCI.

1

2

3

4

A

A

B

B

C

C

D

D



98p
SCALE 2.000



164P
SCALE 2.000

RECOMMENDED FOOTPRINT LAYOUT

www.fciconnect.com			✓ tolerance	projection	MM
Dr	MAGGIE WU	07/23/04	Product family	3G10	size A4
Eng	R Y LIU	07/23/04	Spec ref	*	Scale 1.000
Chr	PAUL WANG	07/23/04	Material	*	ECN DG09-0045
Appr	JOSEPH HSIA	07/23/04			
		PCI EXPRESS PRESS-FIT ASS'Y		dwg no	10039755
catalog no		*		CUSTOMER	sheet 4 of 6

2

3 PDM: Rev:K

STATUS:Released

4 Printed: Mar 15, 2011



Copyright FCI.

NOTES:

1. MATERIAL:

HOUSING: HIGH TEMPERATURE NYLON, GLASS FILLED UL94V-0 RATED. SUITABLE FOR REFLOW SOLDERING.

TERMINAL: COPPER ALLOY

PLATING: 50u" NICKEL UNDERPLATE ALL OVER

CONTACT AREA PLATING - SEE PRODUCT NUMBER CODE

SOLDER TAIL: TIN - 100u" MIN. OVER 50u" NICKEL OR TIN/LEAD 100u" MIN. SEE PRODUCT NUMBER CODE

2. PRODUCT SPECIFICATION: GS-12-319

THE HORIZONTAL AXIS FOR THE HOLE PATTERN IS ESTABLISHED BY A LINE THROUGH THE CENTER OF THE TWO Ø2.35 HOLES. THE VERTICAL AXIS IS 90° TO THE HORIZONTAL AXIS, THROUGH THE CENTER OF DATUM Z.

NO TIE BAR PERMITTED FROM CARD EDGE TO LEADING EDGE OF PAD FOR PINS A1 AND PIN NUMBERS "F".

CHAMFER EDGES MUST BE FREE OF CUTTING BURRS.

ALL PTH SHOULD BE 0.76~0.83 mm DIA DRILLED AND 0.025~0.05 mm. ELECTRO-DEPOSITED COPPER THK ON THROUGH HOLE WALL.

7. RoHS COMPATIBLE PRODUCT SPECIFICATIONS

a-PLATING:

- "LF" MEANS THE PRODUCT IS LEAD-FREE, 2um MINIMUM MATTE TIN OVER 1.27um MINIMUM NICKEL UNDERPLATE.

b-MANUFACTURING PROCESS COMPATIBILITY

- THE HOUSING WILL WITHSTAND EXPOSURE TO 260°C±5°C SOLDER BATH TEMPERATURE FOR 5 SECONDS IN A REFLOW SOLDER APPLICATION WITH A 1.6mm MIN THICK CIRCUIT BOARD.

CONNECTOR	# POS	REF.	N	DIM "A"	DIM "B"	DIM "C"	DIM "E"
1 PORT	36		6	7.65	25.00	9.15	6.00
4 PORT	64		20	21.65	39.00	23.15	20.00
8 PORT	98		37	38.65	56.00	40.15	37.00
16 PORT	164		70	71.65	89.00	73.15	70.00

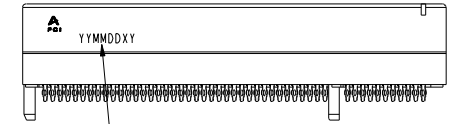

Date code:
 "YY" means year number
 "MM" means month number
 "DD" means day number
 "X" means manufacture location
 "D" means made in Dongguan site
 "Y" means shift number
 If date code is 060626D1, it means this part is made by shift 1 in 2006/06/26 and manufactured in Dongguan site
 Date code should be laser mark

PRODUCT NUMBER CODE

10039755 - X X X X X X X X

HOUSING COLOR OPTIONS
1-BLACK

PEGS OPTIONS
0-PLASTIC PEGS

TERMINAL PLATING OPTIONS

- 0-50u" Ni UNDERPLATE
30u" Au CONTACT AREA
100u" TIN TAIL AREA -----COMPATIBLE RoHS
- 1-50u" Ni UNDERPLATE
15u" Au CONTACT AREA
100u" TIN TAIL AREA -----COMPATIBLE RoHS
- 2-50u" Ni UNDERPLATE
GOLD FLASH CONTACT AREA
100u" TIN TAIL AREA -----COMPATIBLE RoHS
- 3-50u" Ni UNDERPLATE
30u" Au CONTACT AREA
100u" TIN/LEAD TAIL AREA -----RoHS COMPLIANT EXCEPT Pb
- 4-50u" Ni UNDERPLATE
15u" Au CONTACT AREA
100u" TIN/LEAD TAIL AREA -----RoHS COMPLIANT EXCEPT Pb
- 5-50u" Ni UNDERPLATE
GOLD FLASH CONTACT AREA
100u" TIN/LEAD TAIL AREA -----RoHS COMPLIANT EXCEPT Pb

LEAD FREE OPTION
"LF" FOR TERMINAL PLATING OPTION 0,1,2
LEAVE BLANK FOR TERMINAL PLATING 3,4,5

PACKAGING OPTIONS
T-TRAY PACKAGING

POS OPTIONS

- 0-36
- 1-64
- 2-98
- 3-164

TAIL LENGTH OPTIONS

	DIM "D"	SUGGESTED PCB THICKNESS
0	2.00±0.20	2.36
1	3.25±0.20	4.19

tolerance unless otherwise specified	
linear	.X ± .3 .XX ± .2 .XXX ± .1
angles	0° ± 2°

www.fciconnect.com			tolerance	projection	MM
Dr	MAGGIE WU	07/23/04	Product family	size A4	Scale 1.000
Eng	R Y LIU	07/23/04	Spec ref	ECN	DG09-0045
Chr	PAUL WANG	07/23/04	Material		
Appr	JOSEPH HSIA	07/23/04			
PCI EXPRESS PRESS-FIT ASS'Y			dwg no	10039755	Rev. K
catalog no			* CUSTOMER DRAWING sheet 5 of 6		



Copyright FCI.

1

2

3

4

A

B

C

D

A

B

C

D



tolerance unless otherwise specified	
linear	.X ± .3 .XX ± .2 .XXX ± .1
angles	0° ± 2°

www.fciconnect.com			✓ tolerance	projection ⊕	MM ↔
Dr	MAGGIE WU	07/23/04	Product family	size	A4
Eng	R Y LIU	07/23/04	Spec ref	Scale	1.000
Chr	PAUL WANG	07/23/04	Material	ECN	DG09-0045
Appr	JOSEPH HSIA	07/23/04			
FCi			PCI EXPRESS PRESS-FIT ASS'Y	dwg no	10039755
catalog no			* CUSTOMER DRAWING		sheet 6 of 6



Copyright FCI.

2

Данный компонент на территории Российской Федерации

Вы можете приобрести в компании MosChip.

Для оперативного оформления запроса Вам необходимо перейти по данной ссылке:

<http://moschip.ru/get-element>

Вы можете разместить у нас заказ для любого Вашего проекта, будь то серийное производство или разработка единичного прибора.

В нашем ассортименте представлены ведущие мировые производители активных и пассивных электронных компонентов.

Нашей специализацией является поставка электронной компонентной базы двойного назначения, продукции таких производителей как XILINX, Intel (ex.ALTERA), Vicor, Microchip, Texas Instruments, Analog Devices, Mini-Circuits, Amphenol, Glenair.

Сотрудничество с глобальными дистрибьюторами электронных компонентов, предоставляет возможность заказывать и получать с международных складов практически любой перечень компонентов в оптимальные для Вас сроки.

На всех этапах разработки и производства наши партнеры могут получить квалифицированную поддержку опытных инженеров.

Система менеджмента качества компании отвечает требованиям в соответствии с ГОСТ Р ИСО 9001, ГОСТ РВ 0015-002 и ЭС РД 009

Офис по работе с юридическими лицами:

105318, г.Москва, ул.Щербаковская д.3, офис 1107, 1118, ДЦ «Щербаковский»

Телефон: +7 495 668-12-70 (многоканальный)

Факс: +7 495 668-12-70 (доб.304)

E-mail: info@moschip.ru

Skype отдела продаж:

moschip.ru

moschip.ru_4

moschip.ru_6

moschip.ru_9