



Main

Range of product	Harmony XB6E
Product or component type	Monolithic pilot light
Device short name	XB6E
Bezel material	Plastic
Mounting diameter	0.63 in (16 mm)
Sale per indivisible quantity	5
Shape of signaling unit head	Round
Cap/operator or lens colour	Green
Light source	Integral LED
Light block supply	Direct
[Us] rated supply voltage	24 V DC polarised

Complementary

Product weight	0.01 lb(US) (0.006 kg)
Overvoltage category	II conforming to IEC 60536
Operating position	Any position
Marking	CE
Connections - terminals	Fast connector socket Solder terminal, clamping connection $\leq 0.75 \text{ mm}^2$ / AWG 19 min Insulated faston: 2.8 x 0.5 mm
Tightening torque	5.31...8.85 lbf.in (0.6...1 N.m)
[Ui] rated insulation voltage	250 V (degree of pollution: 3) conforming to IEC 60947-1
[Uimp] rated impulse withstand voltage	2.5 kV conforming to IEC 60947-1
Signalling type	Steady
Current consumption	10 mA
Service life	30000 h

Environment

ambient air temperature for storage	-40...158 °F (-40...70 °C)
ambient air temperature for operation	14...131 °F (-10...55 °C)
IP degree of protection	IP65 conforming to IEC 60529
standards	IEC 60947-1 IEC 60947-5-1 JIS C 4520 JIS C 852 UL 508 CSA C22.2 No 14
product certifications	CCC CURus
vibration resistance	1 mm (10...55 Hz) conforming to IEC 60068-2-6
shock resistance	10 gn (duration = 11 ms) half sine wave acceleration conforming to IEC 60068-2-27

Offer Sustainability

WARNING: This product can expose you to chemicals including:	WARNING: This product can expose you to chemicals including:
Nickel compounds, which is known to the State of California to cause cancer, and	Nickel compounds, which is known to the State of California to cause cancer, and
Di-isodecyl phthalate (DIDP), which is known to the State of California to cause birth defects or other reproductive harm.	Di-isodecyl phthalate (DIDP), which is known to the State of California to cause birth defects or other reproductive harm.
For more information go to www.p65warnings.ca.gov	For more information go to www.p65warnings.ca.gov

The information provided in this documentation contains general descriptions and/or technical characteristics of the performance of the products contained herein. This documentation is not intended as a substitute for and is not to be used for determining suitability or reliability of these products for specific user applications. It is the duty of any such user or integrator to perform the appropriate and complete risk analysis, evaluation and testing of the products with respect to the relevant specific application or use thereof. Neither Schneider Electric Industries SAS nor any of its affiliates or subsidiaries shall be responsible or liable for misuse of the information contained herein.

Pilot Light

Circular Head

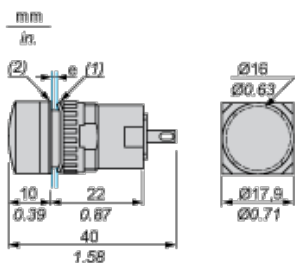

- (1) Anti-rotation plate (thickness: 0.6 mm / 0.02 in.)
- (2) Seal (thickness: 0.5 mm / 0.01 in.)
- e panel thickness: 0.5 mm (0.01 in.) ≤ e ≤ 6 mm (0.24 in.)

Panel Cut-Out and Mounting

Circular or Square Head

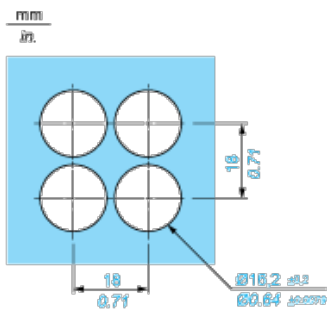

Данный компонент на территории Российской Федерации

Вы можете приобрести в компании MosChip.

Для оперативного оформления запроса Вам необходимо перейти по данной ссылке:

<http://moschip.ru/get-element>

Вы можете разместить у нас заказ для любого Вашего проекта, будь то серийное производство или разработка единичного прибора.

В нашем ассортименте представлены ведущие мировые производители активных и пассивных электронных компонентов.

Нашей специализацией является поставка электронной компонентной базы двойного назначения, продукции таких производителей как XILINX, Intel (ex.ALTERA), Vicor, Microchip, Texas Instruments, Analog Devices, Mini-Circuits, Amphenol, Glenair.

Сотрудничество с глобальными дистрибьюторами электронных компонентов, предоставляет возможность заказывать и получать с международных складов практически любой перечень компонентов в оптимальные для Вас сроки.

На всех этапах разработки и производства наши партнеры могут получить квалифицированную поддержку опытных инженеров.

Система менеджмента качества компании отвечает требованиям в соответствии с ГОСТ Р ИСО 9001, ГОСТ РВ 0015-002 и ЭС РД 009

Офис по работе с юридическими лицами:

105318, г.Москва, ул.Щербаковская д.3, офис 1107, 1118, ДЦ «Щербаковский»

Телефон: +7 495 668-12-70 (многоканальный)

Факс: +7 495 668-12-70 (доб.304)

E-mail: info@moschip.ru

Skype отдела продаж:

moschip.ru

moschip.ru_4

moschip.ru_6

moschip.ru_9