

Wide Band GaAs MMIC Amplifier 0.2 - 3.0 GHz

Rev. V4

Features

- High Gain: 19 dB Typical
- Output Power: +14 dBm Typical
- Noise Figure: 3.7 dB Typical
- RoHS* Compliant

Description

M/A-COM's MAAM02350 is a wide band, MMIC amplifier. It includes two integrated gain stages and employs resistive feedback to obtain flat gain and a good, 50 ohm input, and output impedance match over a very wide bandwidth. The MAAM02350 operates from a single +6 V supply. It is fully monolithic.

The MAAM02350 functions well as a generic IF, driver or buffer amplifier where high gain, low noise figure, excellent linearity and low power consumption are important. Because of its wide bandwidth, the MAAM02350 can be used in numerous commercial and government system applications, such as wireless communications, EW and radar.

The MAAM02350 is manufactured in-house using a reliable, 0.5-micron, GaAs MESFET process. This product is 100% RF tested to ensure compliance to performance specifications.

Absolute Maximum Ratings ^{1,2}

| Parameter | Absolute Maximum |
|----------------------------------|------------------|
| V _{DD} | +7 V |
| Input Power | +20 dBm |
| Channel Temperature ³ | +150°C |
| Operating Temperature | -55°C to +100°C |
| Storage Temperature | -65°C to +150°C |

1. Exceeding any one or combination of these limits may cause permanent damage to this device.
2. M/A-COM does not recommend sustained operation near these survivability limits.
3. Typical thermal resistance (θ_{jc}) = +80°C/W.

Pad Layout

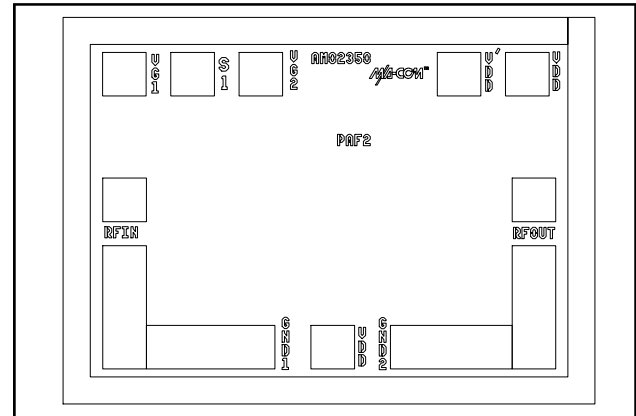

Die Size—Inches (mm)

0.044 x 0.032 x 0.004 (1.140 x 0.820 x 0.102)

Outline Drawing

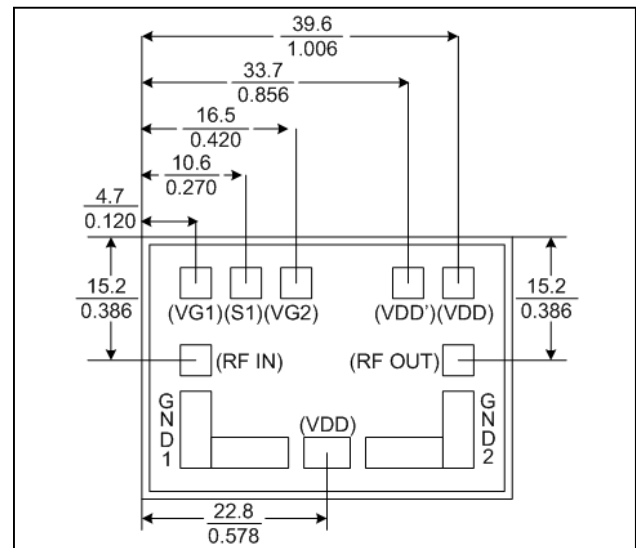

Ordering Information ^{4,5}

| Part Number | Package |
|-------------|---------|
| MAAM02350 | DIE |

4. Reference Application Note M538 for lead-free solder reflow recommendations.
5. Die quantity varies.

* Restrictions on Hazardous Substances, European Union Directive 2002/95/EC.

ADVANCED: Data Sheets contain information regarding a product M/A-COM Technology Solutions is considering for development. Performance is based on target specifications, simulated results, and/or prototype measurements. Commitment to develop is not guaranteed.
PRELIMINARY: Data Sheets contain information regarding a product M/A-COM Technology Solutions has under development. Performance is based on engineering tests. Specifications are typical. Mechanical outline has been fixed. Engineering samples and/or test data may be available. Commitment to produce in volume is not guaranteed.

• **North America** Tel: 800.366.2266 / Fax: 978.366.2266
 • **Europe** Tel: 44.1908.574.200 / Fax: 44.1908.574.300
 • **Asia/Pacific** Tel: 81.44.844.8296 / Fax: 81.44.844.8298
 Visit www.macomtech.com for additional data sheets and product information.

M/A-COM Technology Solutions Inc. and its affiliates reserve the right to make changes to the product(s) or information contained herein without notice.

Wide Band GaAs MMIC Amplifier 0.2 - 3.0 GHz

Rev. V4

Electrical Specifications: $T_A = 25^\circ\text{C}$, $V_{DD} = +6\text{ V}$, $Z_0 = 50\ \Omega$

| Parameter | Test Conditions | Units | Min. | Typ. | Max. |
|-------------------------|--|-------|------|-----------|------|
| Gain | 0.2 - 3.0 GHz, $P_{IN} = -30\text{ dBm}$ | dB | 17 | 19 | — |
| Gain Flatness | 0.2 - 3.0 GHz, $P_{IN} = -30\text{ dBm}$ | dB | — | ± 0.5 | — |
| Noise Figure | 0.2 - 3.0 GHz | dB | — | 3.7 | 4.1 |
| Input VSWR | 0.2 - 3.0 GHz, $P_{IN} = -30\text{ dBm}$ | Ratio | — | 1.8:1 | — |
| Output VSWR | 0.2 - 3.0 GHz, $P_{IN} = -30\text{ dBm}$ | Ratio | — | 1.5:1 | — |
| Output 1 dB Compression | 0.2 - 3.0 GHz | dBm | — | +14 | — |
| OIP3 | 0.2 - 3.0 GHz, $P_{IN} = -30\text{ dBm}$ | dBm | — | 24 | — |
| Reverse Isolation | 0.2 - 3.0 GHz, $P_{IN} = -30\text{ dBm}$ | dB | — | 35 | — |
| Bias Current | — | mA | — | 65 | 100 |

Schematic

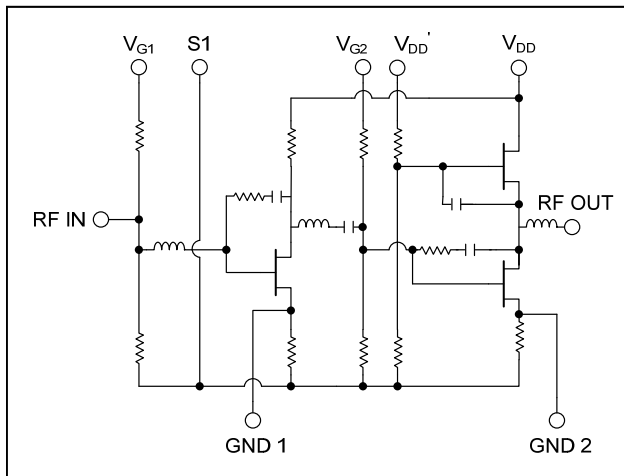

Typical Bias Configuration

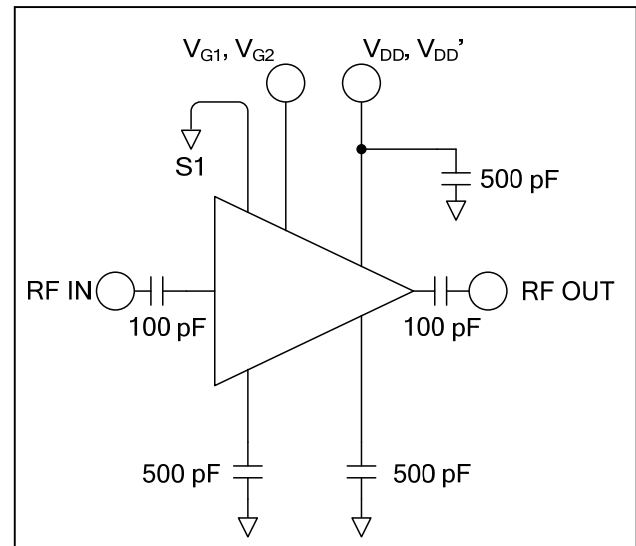

Handling Procedures

Please observe the following precautions to avoid damage:

Static Sensitivity

Gallium Arsenide Integrated Circuits are sensitive to electrostatic discharge (ESD) and can be damaged by static electricity. Proper ESD control techniques should be used when handling these devices.

- Self-bias operation is obtained by connecting +6 volts to both V_{DD} and V_{DD}' pads, grounding pad S1, and connecting pads GND1 and GND2 to separate bypass 500 pF MOS capacitors.

Typical Performance @ +25°C

Gain

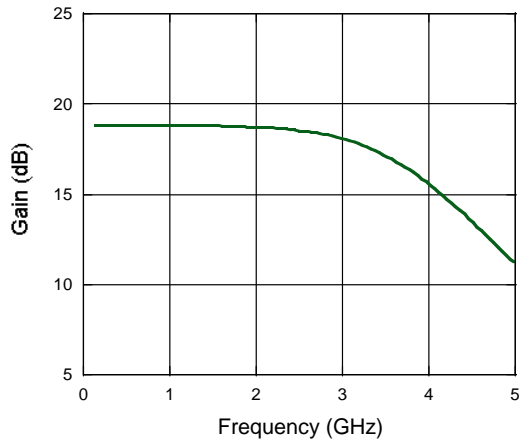

VSWR

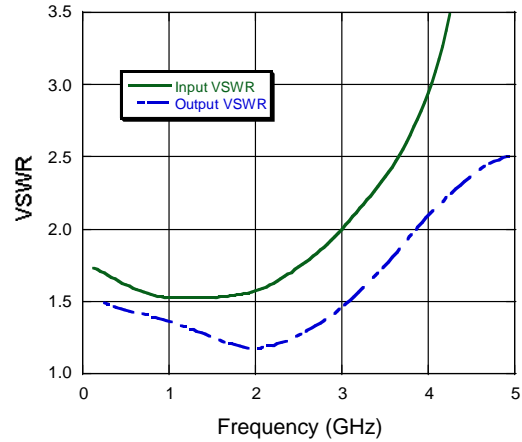

Noise Figure

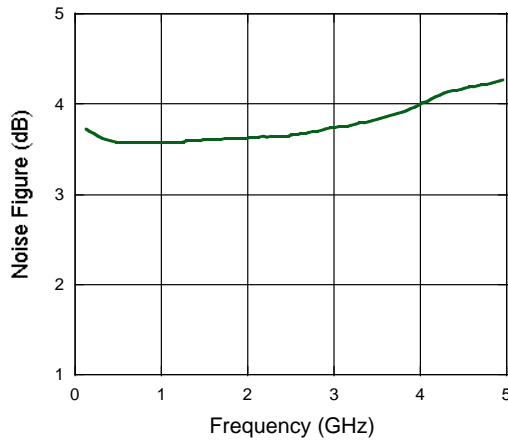

Handling

Permanent damage to the MAAM02350 may occur if the following precautions are not adhered to:

- A. Cleanliness - The MAAM02350 should be handled in a clean environment. Do not attempt to clean assembly after the MAAM02350 is installed.
- B. Static Sensitivity - All die handling equipment and personnel should comply with DOD-STD-1686 Class 1.
- C. Transients - Avoid instrument and power supply transients while bias is connected to the MAAM02350. Use shielded signal and bias cables to minimize inductive pick-up.
- D. General Handling - DO NOT touch the surface of the die. It is recommended that the MAAM02350 die be handled along the long side with a sharp pair of tweezers.

Mounting

The MAAM02350 is back-metallized with Pd/Ni/Au (100/1,000/30,000Å) metallization. It can be die-mounted using Au/Sn eutectic performs or a thermally and electrically conductive epoxy. The attachment surface should be clean and flat.

Eutectic Die Attach:

- A. An 80/20 Au/Sn perform is recommended with a work surface temperature of approximately 225°C and a tool temperature of 265°C. When hot 95/5 nitrogen/hydrogen gas is applied, solder temperature should be approximately 290°C.
- B. DO NOT expose the MAAM02350 to a temperature greater than 320°C for more than 20 seconds. No more than 3 seconds of scrubbing should be required for attachment.

Epoxy Die Attach:

- A. Apply a minimum amount of epoxy and place the MAAM02350 into position. A thin epoxy fillet should be visible around the perimeter of the die.
- B. Cure epoxy per manufacturer's recommended schedule.

Bonding

- A. Ball or wedge bond with 1.0 mil diameter gold wire or 3.0 mil x 0.5 mil ribbon. Thermosonic bonding with a nominal stage temperature of 150°C and a ball bonding force of 40 to 50 grams or wedge bonding force of 18 to 22 grams is recommended. Ultrasonic energy and time should be adjusted to the minimum levels necessary to achieve reliable bonds.
- B. Bonds should be started on the die and terminated on the package. RF bonds should be as short as possible; at least three and no more than four bond wires from ground pads to package are recommended.
- C. Bonding pads are 4.0 x 4.0 mils.

Данный компонент на территории Российской Федерации

Вы можете приобрести в компании MosChip.

Для оперативного оформления запроса Вам необходимо перейти по данной ссылке:

<http://moschip.ru/get-element>

Вы можете разместить у нас заказ для любого Вашего проекта, будь то серийное производство или разработка единичного прибора.

В нашем ассортименте представлены ведущие мировые производители активных и пассивных электронных компонентов.

Нашей специализацией является поставка электронной компонентной базы двойного назначения, продукции таких производителей как XILINX, Intel (ex.ALTERA), Vicor, Microchip, Texas Instruments, Analog Devices, Mini-Circuits, Amphenol, Glenair.

Сотрудничество с глобальными дистрибьюторами электронных компонентов, предоставляет возможность заказывать и получать с международных складов практически любой перечень компонентов в оптимальные для Вас сроки.

На всех этапах разработки и производства наши партнеры могут получить квалифицированную поддержку опытных инженеров.

Система менеджмента качества компании отвечает требованиям в соответствии с ГОСТ Р ИСО 9001, ГОСТ РВ 0015-002 и ЭС РД 009

Офис по работе с юридическими лицами:

105318, г.Москва, ул.Щербаковская д.3, офис 1107, 1118, ДЦ «Щербаковский»

Телефон: +7 495 668-12-70 (многоканальный)

Факс: +7 495 668-12-70 (доб.304)

E-mail: info@moschip.ru

Skype отдела продаж:

moschip.ru

moschip.ru_4

moschip.ru_6

moschip.ru_9