

SAB CONNECTOR

Wire-to-wire

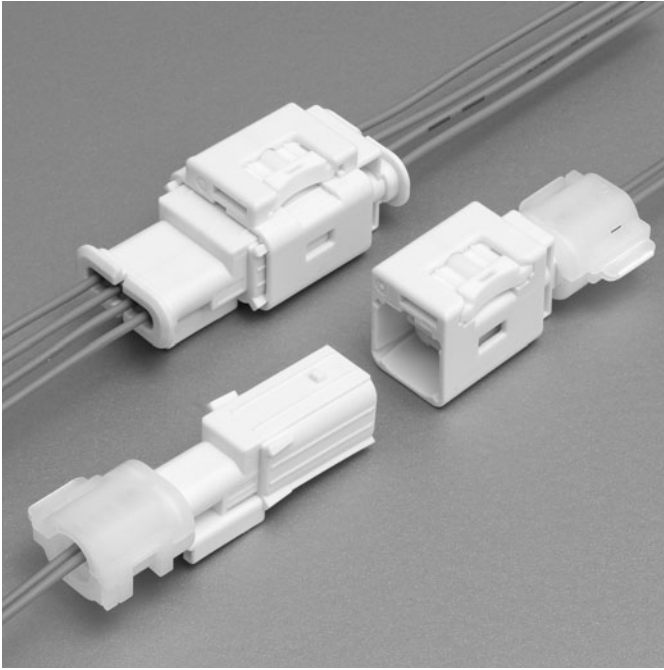

Features

- **0.64mm Single Sealed Connector for Air-bag Application**
- **Anti Vibration Mechanism**
High reliability rigid connector enables to keep higher durability at shock and vibrated environment.
- **Fool Proof Systems**
Compression spring prevents half-connecting.

0.64mm single sealed wire to wire connector with rigid design and spring lock mechanism for air-bag application.

Spring force prevents half-mating during mating and keeps constant rigid connection between male and female connector.

This connector has short terminal to prevent accidental electrical discharge.

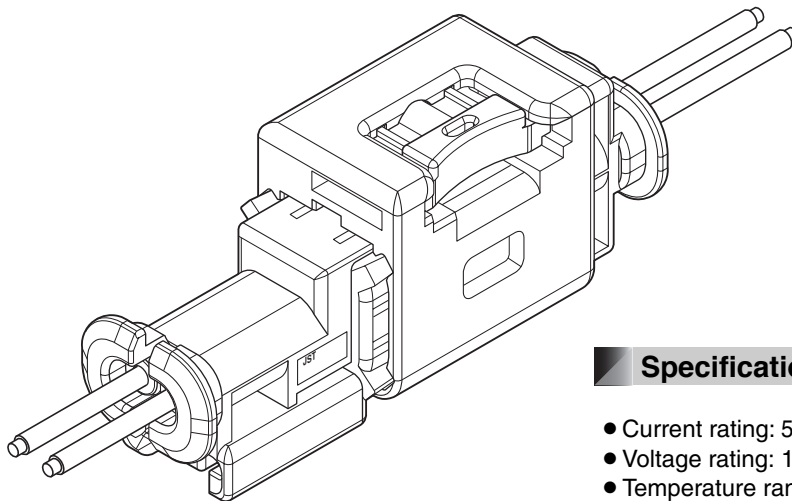

Specifications

- Current rating: 5A AC, DC max.
- Voltage rating: 14V DC
- Temperature range: -40°C to +80°C
(including temperature rise in applying electrical current)
- Contact resistance: Initial value/10mΩ max.
After environmental testing/20mΩ max.
- Insulation resistance: 100MΩ min.
- Withstanding voltage: 1,000V AC/minute
- Applicable wire: AVSS 0.5mm²

- * Compliant with ELV/RoHS.
- * Contact JST for details.

Female terminal

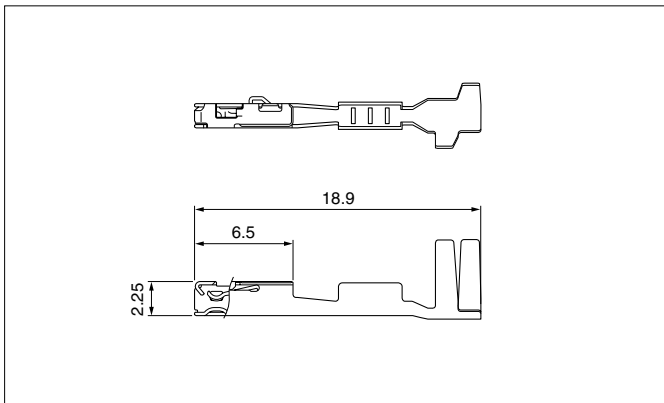

Model No.	Applicable wire range		Q'ty/reel
	Conductor (mm ²)	Insulation O.D. (mm)	
SAITS-A03GF-M064	0.5	1.6 to 1.7	3,500

Material and Finish

Copper alloy, nickel-undercoated, Contact area; gold-plated
Barrel area; tin-plated

Female connector

• 2 circuits

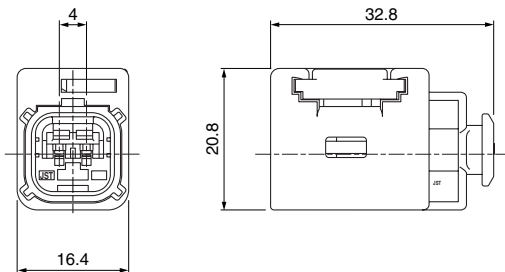
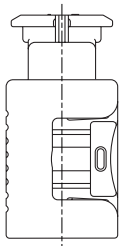

• 4 circuits

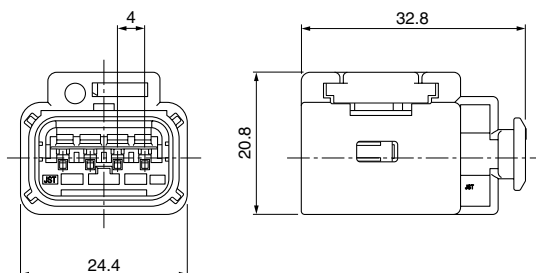
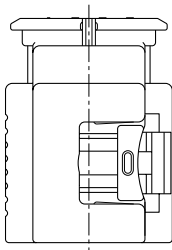

Circuits	Model No.	Q'ty/box
2	SABRB-02-1A-Y	125
4	SABRB-04-1A-Y	100

Material

Housing: Glass-filled PBT, yellow
Slider: Glass-filled PBT, natural (white)
Retainer: Glass-filled PBT, natural (white)
Spring: SUS
Inner seal: Silicone

SAB CONNECTOR

Male terminal

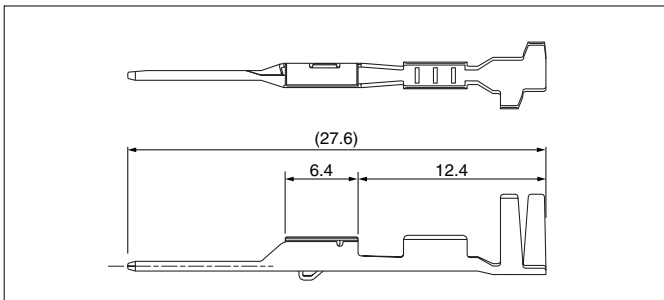

Model No.	Applicable wire range		Q'ty/reel
	Conductor (mm ²)	Insulation O.D. (mm)	
SAITWS-A03GF-064	0.5	1.6 to 1.7	3,500

Material and Finish

Brass, nickel-undercoated, Contact area; gold-plated
Barrel area; tin-plated

Male connector

• 2 circuits

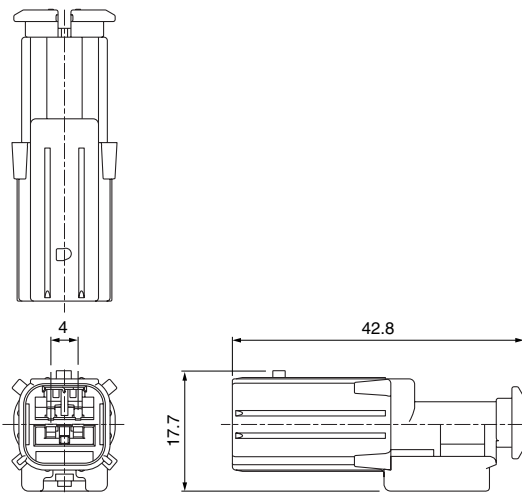

• 4 circuits

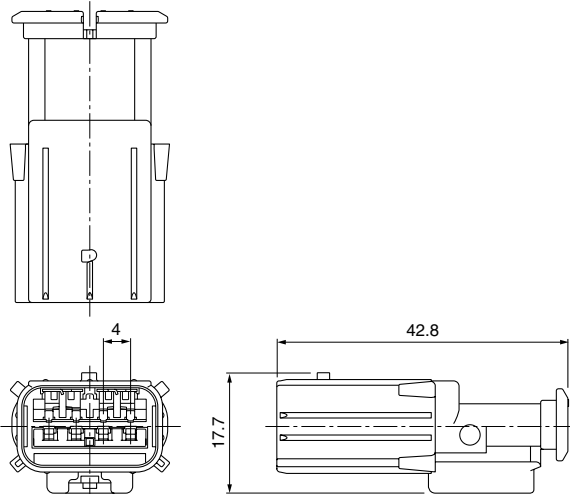

Circuits	Model No.	Q'ty/box
2	SABPB-02-1A-Y	125
4	SABPB-04-1A-Y	100

Material and Finish

Housing: Glass-filled PBT, yellow
Retainer: Glass-filled PBT, natural (white)
Short terminal: Copper alloy, nickel-undercoated, Contact area; gold-plated

Wire seal

• 2, 4 circuits

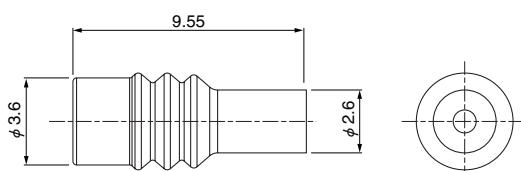

Model No.	Applicable wire range		Q'ty/box
	Conductor (mm ²)	Insulation O.D. (mm)	
A03WS-SAB-N	0.5	1.6 to 1.7	10,000

Material

Silicone

Cover

• 2 circuits

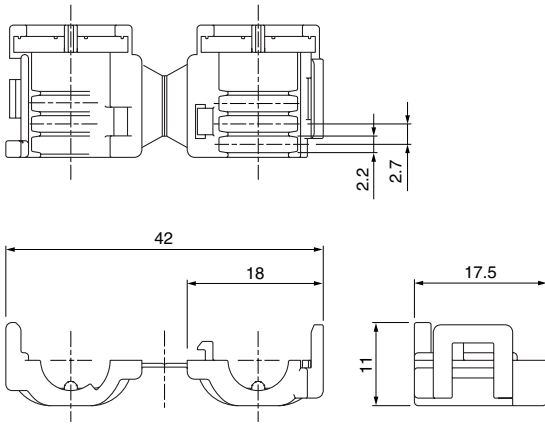

Recommended corrugate tube layout

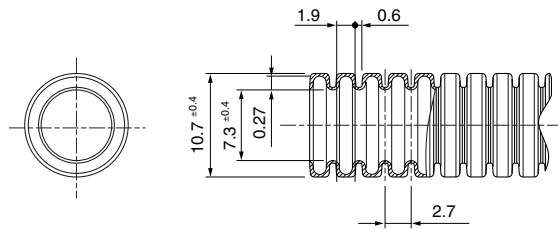

Model No.	Q'ty/box
Note) SABC-02-1A-W	200
Material	
PP, natural (white)	

Note: Cover is applicable only for 2 circuits.

Assembly layout

• 2, 4 circuits

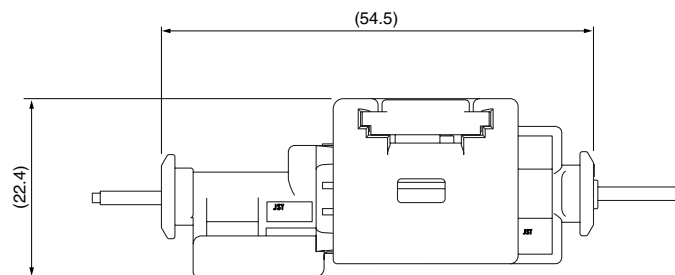

Cassette layout

Recommended bracket layout

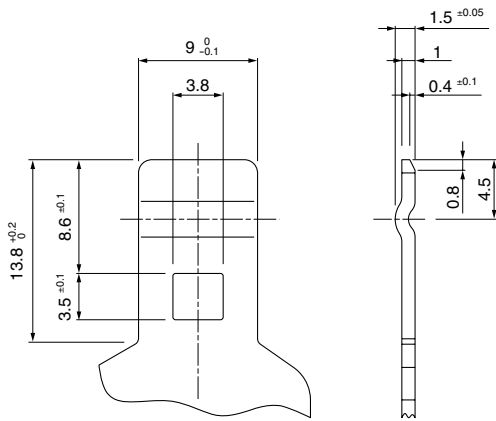

Recommended clip layout

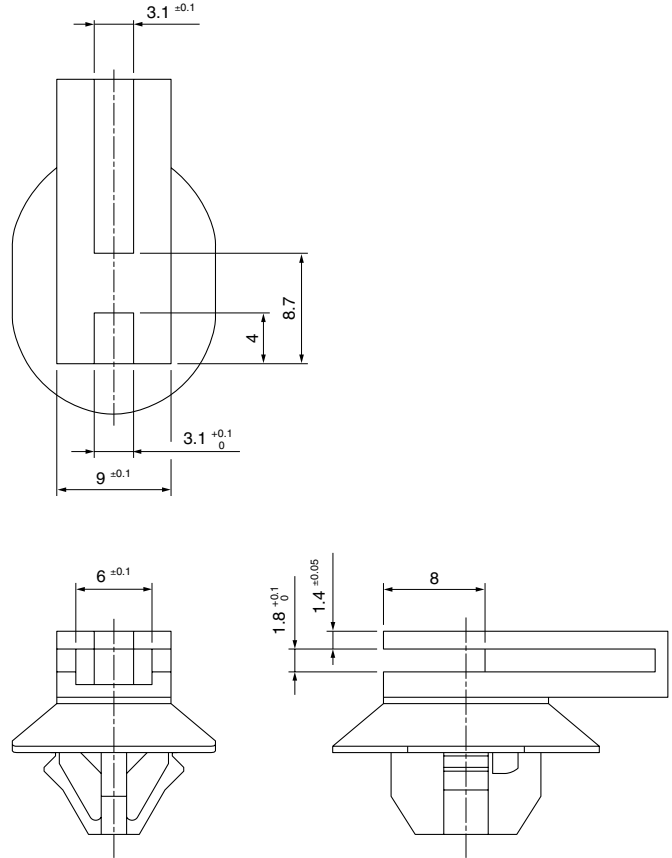

Note: 1. The dimensions above should serve as guideline. Contact JST for details.
2. JST recommends to use clip which is made of PA.

Crimping machine, Applicator

Strip terminal	Crimping machine	Crimp applicator MKS-L	
		Dies	Crimp applicator with dies
SAITS-A03GF-M064	AP-K2N	MK/SAITS-A03-064	APLMK SAITS-A03-064
SAITWS-A03GF-064		MK/SAITWS-A03-064	APLMK SAITWS-A03-064

Note: When crimping operation is conducted using an applicator and die set other than the above, JST cannot guarantee the performance of the terminal.

Mouser Electronics

Authorized Distributor

Click to View Pricing, Inventory, Delivery & Lifecycle Information:

JST:

[SABC-02-1A-W](#) [SABRB-02-1A-Y](#) [SABPB-02-1AY](#) [A03WS-SAB-N](#) [SABPB-02-1A-Y \(B\)](#) [SAITS-A03GF-M064-A](#)
[SAITWS-A03GF-064](#)

Данный компонент на территории Российской Федерации

Вы можете приобрести в компании MosChip.

Для оперативного оформления запроса Вам необходимо перейти по данной ссылке:

<http://moschip.ru/get-element>

Вы можете разместить у нас заказ для любого Вашего проекта, будь то серийное производство или разработка единичного прибора.

В нашем ассортименте представлены ведущие мировые производители активных и пассивных электронных компонентов.

Нашей специализацией является поставка электронной компонентной базы двойного назначения, продукции таких производителей как XILINX, Intel (ex.ALTERA), Vicor, Microchip, Texas Instruments, Analog Devices, Mini-Circuits, Amphenol, Glenair.

Сотрудничество с глобальными дистрибьюторами электронных компонентов, предоставляет возможность заказывать и получать с международных складов практически любой перечень компонентов в оптимальные для Вас сроки.

На всех этапах разработки и производства наши партнеры могут получить квалифицированную поддержку опытных инженеров.

Система менеджмента качества компании отвечает требованиям в соответствии с ГОСТ Р ИСО 9001, ГОСТ РВ 0015-002 и ЭС РД 009

Офис по работе с юридическими лицами:

105318, г.Москва, ул.Щербаковская д.3, офис 1107, 1118, ДЦ «Щербаковский»

Телефон: +7 495 668-12-70 (многоканальный)

Факс: +7 495 668-12-70 (доб.304)

E-mail: info@moschip.ru

Skype отдела продаж:

moschip.ru

moschip.ru_4

moschip.ru_6

moschip.ru_9