

# HDSP-521A/523A

14.22 mm (0.56 inch) Dual Digit General Purpose  
Seven Segment Display

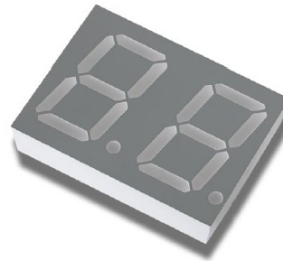

## Data Sheet



### Description

The 14.22 mm (0.56 inch) LED dual digit seven segment displays use industry standard size package and pinout. The device is available in either common anode or common cathode. These gray face displays are suitable for indoor use.

### Devices

AlGaAs Red	Description
HDSP-521A	Common Anode Right Hand Decimal
HDSP-523A	Common Cathode Right Hand Decimal

### Features

- Industry standard size
- Industry standard pinout  
14.22 mm (0.56 inch)  
DIP lead on 2.54 mm
- AlGaAs Red color
- Excellent appearance  
Evenly lighted segments gray package gives optimum contrast  $\pm 50$  ft. viewing angle
- Design flexibility  
Common anode right hand decimal point or common cathode right hand decimal point

### Applications

- Suitable for indoor use
- Not recommended for industrial application, i.e., operating temperature requirements exceeding  $+85^{\circ}\text{C}$  or below  $-35^{\circ}\text{C}$ <sup>[1]</sup>
- Extreme temperature cycling not recommended

Note:

1. For additional details, please contact your local Avago sales office or an authorized distributor.

## Part Numbering System

5082 - x xx x - x x x xx  
 HDSP - x xx x - x x x xx

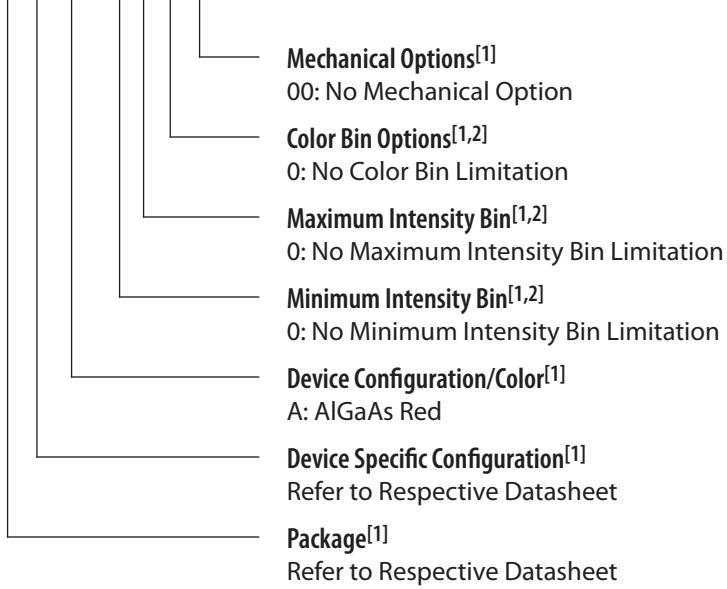

Notes:

1. For codes not listed in the figure above, please refer to the respective data sheet or contact your nearest Avago representative for details.
2. Bin options refer to shippable bins for a part number. Color and Intensity Bins are typically restricted to 1 bin per tube (exceptions may apply). Please refer to respective data sheet for specific bin limit information.

# Package Dimensions

TOP END VIEW

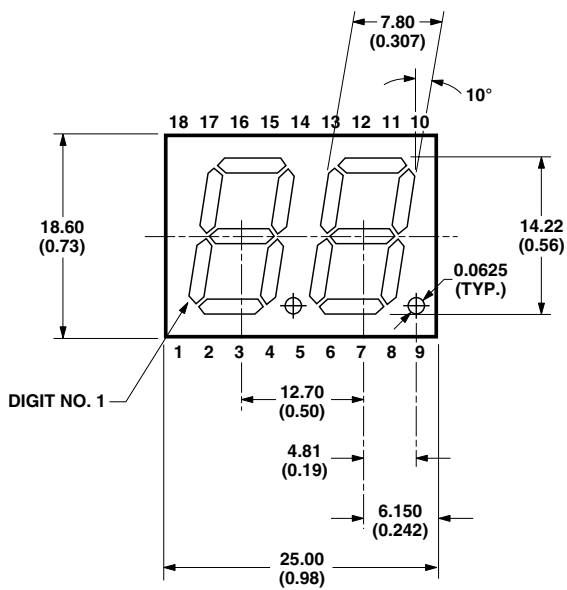
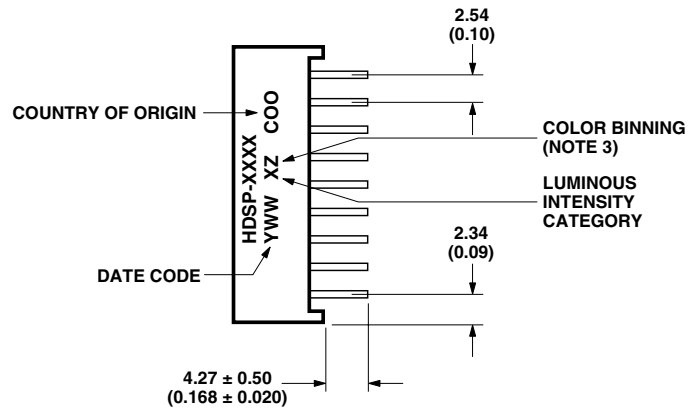

FRONT VIEW

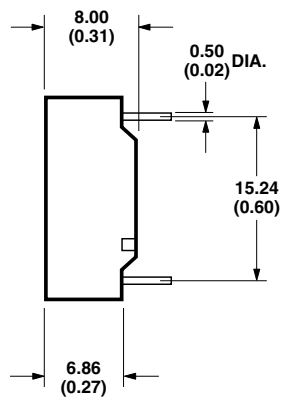

SIDE VIEW

ALL DIMENSIONS ARE IN MILLIMETERS (INCHES).

## Internal Circuit Diagram

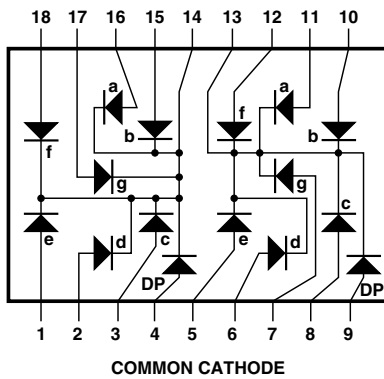
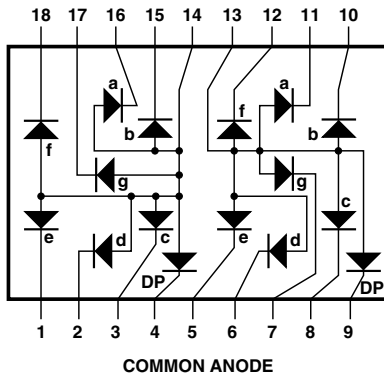

COMMON ANODE		COMMON CATHODE	
PIN	FUNCTION	PIN	FUNCTION
1	E CATHODE NO. 1	1	E ANODE NO. 1
2	D CATHODE NO. 1	2	D ANODE NO. 1
3	C CATHODE NO. 1	3	C ANODE NO. 1
4	DP CATHODE NO. 1	4	DP ANODE NO. 1
5	E CATHODE NO. 2	5	E ANODE NO. 2
6	D CATHODE NO. 2	6	D ANODE NO. 2
7	G CATHODE NO. 2	7	G ANODE NO. 2
8	C CATHODE NO. 2	8	C ANODE NO. 2
9	DP CATHODE NO. 2	9	DP ANODE NO. 2
10	B CATHODE NO. 2	10	B ANODE NO. 2
11	A CATHODE NO. 2	11	A ANODE NO. 2
12	F CATHODE NO. 2	12	F ANODE NO. 2
13	DIGIT NO. 2 ANODE	13	DIGIT NO. 2 CATHODE
14	DIGIT NO. 1 ANODE	14	DIGIT NO. 1 CATHODE
15	B CATHODE NO. 1	15	B ANODE NO. 1
16	A CATHODE NO. 1	16	A ANODE NO. 1
17	G CATHODE NO. 1	17	G ANODE NO. 1
18	F CATHODE NO. 1	18	F ANODE NO. 1

## Absolute Maximum Ratings at $T_A = 25^\circ\text{C}$

Parameter	AlGaAs Red HDSP-52xA	
	Units	
Power Dissipation Segment	30	mW
Forward Current Segment	15 <sup>[1]</sup>	mA
Peak Forward Current per Segment (1/10 Duty Factor at 10 KHz)	80	mA
Operating Temperature Range	-35 to +85	°C
Storage Temperature Range	-35 to +85	°C
Reverse Voltage per Segment or DP	5	V
Wavesoldering Temperature for 3 seconds (at 2 mm Distance from the body)	250	°C

### Notes:

- Derate above  $25^\circ\text{C}$  at  $0.2\text{ mA}/^\circ\text{C}$ .

## Intensity Bin Limits (mcd at 10 mA)

Bin Name	AlGaAs Red	
	Min. <sup>[1]</sup>	Max. <sup>[1]</sup>
J	3.201	5.050
K	5.051	8.000
L	8.001	12.650

### Note:

- Tolerance for each bin limit is  $\pm 10\%$ .

## Electrical/Optical Characteristics at TA = 25°C

### AlGaAs Red

Device HDSP-	Parameter	Symbol	Min.	Typ.	Max.	Units	Test Conditions
521A 523A	Luminous Intensity/Segment	$I_V$	3.201	3.66	6.500	mcd	$I_F = 5 \text{ mA}$
				mcd		$I_F = 10 \text{ mA}$	
	Forward Voltage	$V_F$		1.85	2.00	V	$I_F = 20 \text{ mA}$
	Peak Wavelength	$\lambda_{PEAK}$		660		nm	
	Dominant Wavelength	$\lambda_d$		643		nm	
	Reverse Voltage	$V_R$	5			V	$I_R = 100 \mu\text{A}$

### AlGaAs Red

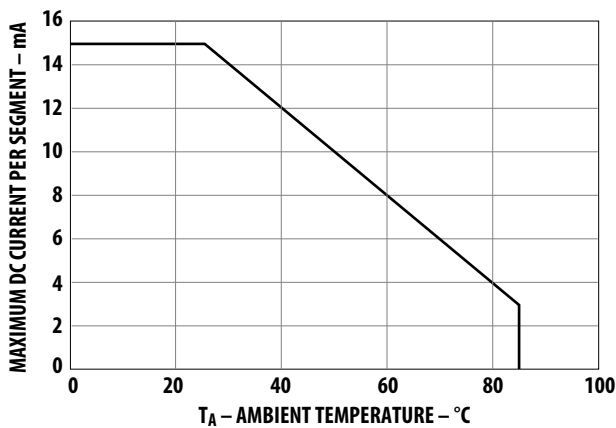

Figure 1. Maximum allowable average or DC current vs. ambient temperature.

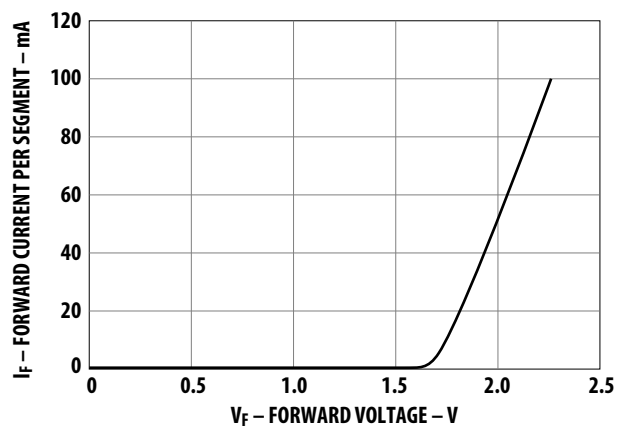

Figure 2. Forward current vs. forward voltage.

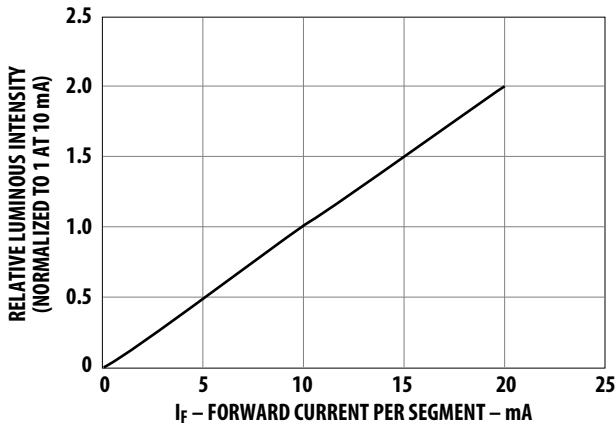

Figure 3. Relative luminous intensity vs. DC forward current.

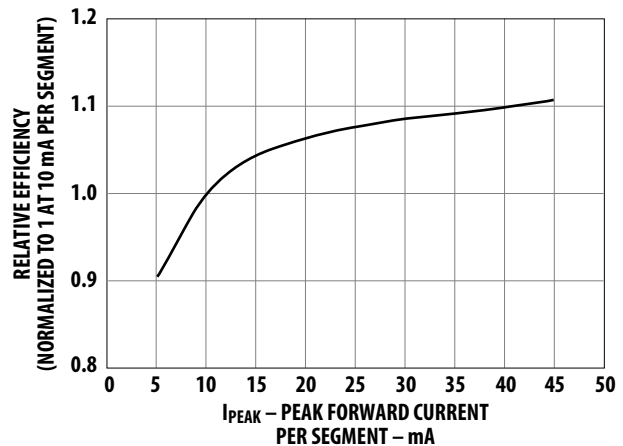

Figure 4. Relative efficiency (luminous intensity per unit current) vs. peak current.

For product information and a complete list of distributors, please go to our web site: [www.avagotech.com](http://www.avagotech.com)

## Данный компонент на территории Российской Федерации

### Вы можете приобрести в компании MosChip.

Для оперативного оформления запроса Вам необходимо перейти по данной ссылке:

<http://moschip.ru/get-element>

Вы можете разместить у нас заказ для любого Вашего проекта, будь то серийное производство или разработка единичного прибора.

В нашем ассортименте представлены ведущие мировые производители активных и пассивных электронных компонентов.

Нашей специализацией является поставка электронной компонентной базы двойного назначения, продукции таких производителей как XILINX, Intel (ex.ALTERA), Vicor, Microchip, Texas Instruments, Analog Devices, Mini-Circuits, Amphenol, Glenair.

Сотрудничество с глобальными дистрибьюторами электронных компонентов, предоставляет возможность заказывать и получать с международных складов практически любой перечень компонентов в оптимальные для Вас сроки.

На всех этапах разработки и производства наши партнеры могут получить квалифицированную поддержку опытных инженеров.

Система менеджмента качества компании отвечает требованиям в соответствии с ГОСТ Р ИСО 9001, ГОСТ РВ 0015-002 и ЭС РД 009

### Офис по работе с юридическими лицами:

105318, г.Москва, ул.Щербаковская д.3, офис 1107, 1118, ДЦ «Щербаковский»

Телефон: +7 495 668-12-70 (многоканальный)

Факс: +7 495 668-12-70 (доб.304)

E-mail: [info@moschip.ru](mailto:info@moschip.ru)

Skype отдела продаж:

moschip.ru

moschip.ru\_4

moschip.ru\_6

moschip.ru\_9