

FEATURES AND BENEFITS*

- 16V DC working voltage
- Resistive cell balancing
- Compact, light weight package
- Screw terminals

TYPICAL APPLICATIONS

- Wind turbine pitch control
- Small UPS systems

**PRODUCT SPECIFICATIONS****ELECTRICAL****BMOD0058 E016 B02**

Rated Capacitance ¹	58 F
Minimum Capacitance, initial ¹	58 F
Maximum Capacitance, initial ¹	70 F
Maximum ESR _{DC} , initial ¹	22 mΩ
Test Current for Capacitance and ESR _{DC} ¹	35 A
Rated Voltage	16 V
Absolute Maximum Voltage ²	17 V
Absolute Maximum Current	170 A
Leakage Current at 25°C, maximum ³	25 mA
Maximum Series Voltage	750 V
Capacitance of Individual Cells ⁹	350 F
Maximum Stored Energy, Individual Cell ⁹	0.35 Wh
Number of Cells	6

TEMPERATURE

Operating Temperature (Cell Case Temperature)	
Minimum	-40°C
Maximum	65°C
Storage Temperature (Stored Uncharged)	
Minimum	-40°C
Maximum	70°C

*Results may vary. Additional terms and conditions, including the limited warranty, apply at the time of purchase. See the warranty details for applicable operating and use requirements.

PRODUCT SPECIFICATIONS (Cont'd)

PHYSICAL

BMOD0058 E016 B02

Mass, typical	0.63 kg
Power Terminals	M5 Thread
Recommended Torque - Terminal	4 Nm
Vibration Specification	IEC60068-2-6
Shock Specification	IEC60068-2-27, -29
Environmental Protection	IP54
Cooling	Natural Convection

MONITORING / CELL VOLTAGE MANAGEMENT

Internal Temperature Sensor	N/A
Temperature Interface	N/A
Cell Voltage Monitoring	N/A
Connector	N/A
Cell Voltage Management	Passive

POWER & ENERGY

Usable Specific Power, P_d^4	2,200 W/kg
Impedance Match Specific Power, P_{max}^5	4,600 W/kg
Specific Energy, E_{max}^6	3.3 Wh/kg
Stored Energy, $E_{stored}^{7,9}$	2.1 Wh

SAFETY

Short Circuit Current, typical (Current possible with short circuit from rated voltage. Do not use as an operating current.)	730 A
Certifications	RoHS, UL810a (640 Volts)
High-Pot Capability ¹⁰	5,600 VDC

TYPICAL CHARACTERISTICS

THERMAL CHARACTERISTICS

BMOD0058 E016 B02

Thermal Resistance (R_{ca} , All Cell Cases to Ambient), typical ⁸	4.8°C/W
Thermal Capacitance (C_{th}), typical	420 J/°C
Maximum Continuous Current ($\Delta T = 15^\circ\text{C}$) ⁸	12 A _{RMS}
Maximum Continuous Current ($\Delta T = 40^\circ\text{C}$) ⁸	19 A _{RMS}

LIFE

DC Life at High Temperature ¹ (held continuously at Rated Voltage and Maximum Operating Temperature)	1,500 hours
Capacitance Change (% decrease from minimum initial value)	20%
ESR Change (% increase from maximum initial value)	100%
Projected DC Life at 25°C ¹ (held continuously at Rated Voltage)	10 years
Capacitance Change (% decrease from minimum initial value)	20%
ESR Change (% increase from maximum initial value)	100%
Shelf Life (Stored uncharged at 25°C)	4 years

ESR AND CAPACITANCE VS TEMPERATURE

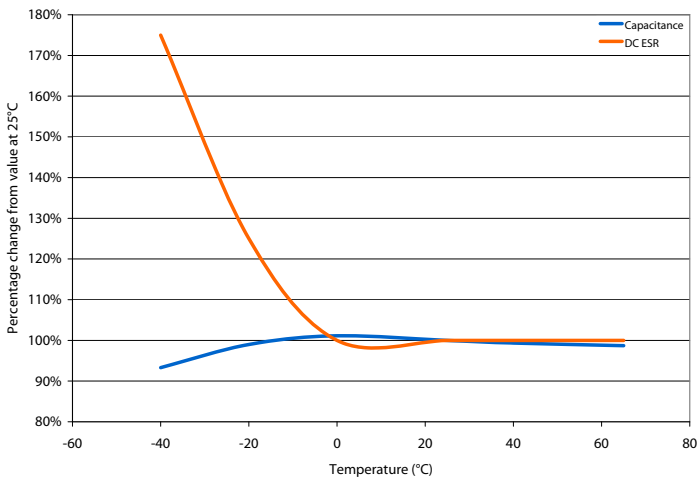

NOTES

1. Capacitance and ESR_{DC} measured at 25°C using specified test current per waveform below.
2. Absolute maximum voltage, non-repeated. Not to exceed 1 second.
3. After 72 hours at rated voltage. Initial leakage current can be higher.
4. Per IEC 62391-2, $P_d = \frac{0.12V^2}{ESR_{DC} \times \text{mass}}$
5. $P_{\text{max}} = \frac{V^2}{4 \times ESR_{DC} \times \text{mass}}$
6. $E_{\text{max}} = \frac{1/2 CV^2}{3,600 \times \text{mass}}$
7. $E_{\text{stored}} = \frac{1/2 CV^2}{3,600}$
8. $\Delta T = I_{RMS}^2 \times ESR \times R_{ca}$
9. Per United Nations material classification UN3499, all Maxwell ultracapacitors have less than 10 Wh capacity to meet the requirements of Special Provisions 361. Both individual ultracapacitors and modules composed of those ultracapacitors shipped by Maxwell can be transported without being treated as dangerous goods (hazardous materials) under transportation regulations.
10. Duration = 60 seconds. Not intended as an operating parameter.

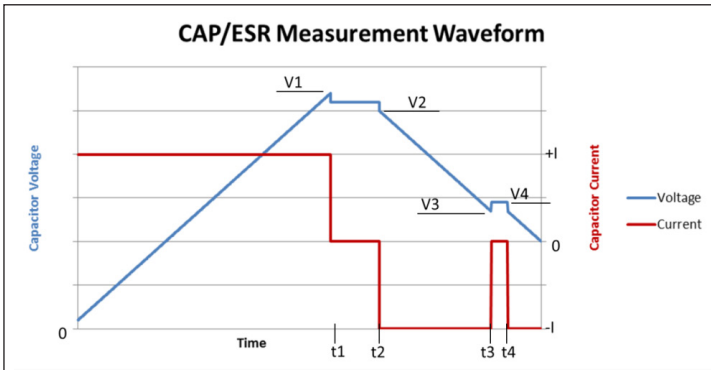

$V1 = V_{\text{rated}}$ $t2 - t1 = 15 \text{ seconds}$ Capacitance = $I \times (t3-t2)/(V2-V3)$
 $V3 = 0.5 \times V_{\text{rated}}$ $t4 - t3 = 5 \text{ seconds}$ $ESR = (V4 - V3)/I$

MOUNTING RECOMMENDATIONS

Recommended mounting screw M4. Maximum torque on mounting screws 4 Nm. All 6 mounting locations must be utilized to meet vibration specifications.

MARKINGS

Products are marked with the following information: Rated capacitance, rated voltage, product number, name of manufacturer, positive and negative terminal, and serial number.

BMOD0058 E016 B02

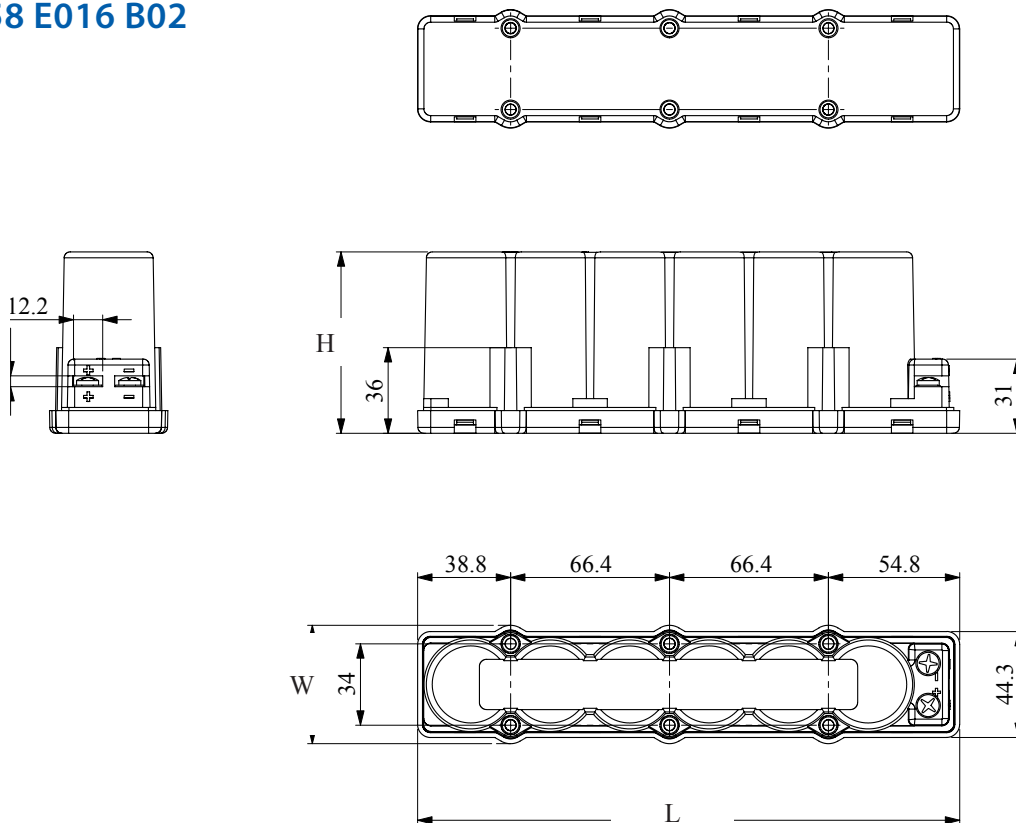

Part Description	Dimensions (mm)			Package Quantity
	L (±0.5mm)	W (±0.5m)	H (±0.5mm)	
BMOD0058 E016 B02	226.5	49.5	76.0	10

Product dimensions are for reference only unless otherwise identified. Product dimensions and specifications may change without notice. Please contact Maxwell Technologies directly for any technical specifications critical to application. All products featured on this datasheet are covered by the following U.S. patents and their respective foreign counterparts: 6643119, 7295423, 7342770, 7352558, 7384433, 7492571, 7508651, 7791860, 7791861, 7883553, 7935155, 8072734, 8279580, and patents pending.



Maxwell Technologies, Inc.
Global Headquarters
 3888 Calle Fortunada
 San Diego, CA 92123
 USA
 Tel: +1 858 503 3300
 Fax: +1 858 503 3301



Maxwell Technologies SA
 Route de Montena 65
 CH-1728 Rossens
 Switzerland
 Tel: +41 (0)26 411 85 00
 Fax: +41 (0)26 411 85 05



Maxwell Technologies, GmbH
 Leopoldstrasse 244
 80807 München
 Germany
 Tel: +49 (0)89 / 4161403 0
 Fax: +49 (0)89 / 4161403 99



Maxwell Technologies, Inc.
Shanghai Trading Co. Ltd.
 Unit A2,C 12th Floor
 Huarun Times Square
 500 Zhangyang Road,
 Pudong New Area
 Shanghai 200122,
 P.R. China
 Phone: +86 21 3852 4000
 Fax: +86 21 3852 4099

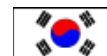

Maxwell Technologies Korea Co., Ltd.
 Room 1524, D-Cube City
 Office Tower, 15F #662
 Gyeongin-Ro, Guro-Gu,
 Seoul, 152-706
 South Korea
 Phone: +82 10 4518 9829

MAXWELL TECHNOLOGIES, MAXWELL, MAXWELL CERTIFIED INTEGRATOR, ENABLING ENERGY'S FUTURE, BOOSTCAP, C CELL, D CELL and their respective designs and/or logos are either trademarks or registered trademarks of Maxwell Technologies, Inc. and may not be copied, imitated or used, in whole or in part, without the prior written permission Maxwell Technologies, Inc. All contents copyright © 2014 Maxwell Technologies, Inc. All rights reserved. No portion of these materials may be reproduced in any form, or by any means, without prior written permission from Maxwell Technologies, Inc.

Данный компонент на территории Российской Федерации

Вы можете приобрести в компании MosChip.

Для оперативного оформления запроса Вам необходимо перейти по данной ссылке:

<http://moschip.ru/get-element>

Вы можете разместить у нас заказ для любого Вашего проекта, будь то серийное производство или разработка единичного прибора.

В нашем ассортименте представлены ведущие мировые производители активных и пассивных электронных компонентов.

Нашей специализацией является поставка электронной компонентной базы двойного назначения, продукции таких производителей как XILINX, Intel (ex.ALTERA), Vicor, Microchip, Texas Instruments, Analog Devices, Mini-Circuits, Amphenol, Glenair.

Сотрудничество с глобальными дистрибьюторами электронных компонентов, предоставляет возможность заказывать и получать с международных складов практически любой перечень компонентов в оптимальные для Вас сроки.

На всех этапах разработки и производства наши партнеры могут получить квалифицированную поддержку опытных инженеров.

Система менеджмента качества компании отвечает требованиям в соответствии с ГОСТ Р ИСО 9001, ГОСТ РВ 0015-002 и ЭС РД 009

Офис по работе с юридическими лицами:

105318, г.Москва, ул.Щербаковская д.3, офис 1107, 1118, ДЦ «Щербаковский»

Телефон: +7 495 668-12-70 (многоканальный)

Факс: +7 495 668-12-70 (доб.304)

E-mail: info@moschip.ru

Skype отдела продаж:

moschip.ru

moschip.ru_4

moschip.ru_6

moschip.ru_9