

## DESCRIPTION

Demonstration circuit 1309 features the LT3474-1 36V step-down 1A LED driver. The demonstration circuit is designed to drive a string of 1A LEDs from a high input voltage. The high switching frequency scheme permits the use of small inductors and ceramic capacitors to save space and cost. The current mode control scheme provides fast transient response and cycle-by-cycle current limiting. Frequency foldback and thermal shutdown provide additional protection. The external clamp provides open LED protection. The LT3474-1 can be dimmed with an analog CTRL pin or with a PWM dimming input. The typical efficiency of the LT3474-1 DC1309 is 90.4% with 32VIN and an 8-LED string of 23V driven at 1A.

A few simple modifications can be made to DC1309 in order to add PWM dimming to the circuit. The LED string cathode can be connected to LED- and one of the PWM dimming MOSFETs can be stuffed in Q1 or Q2 location for the PWM dimming function. Without PWM dimming, the cathode of the LED string should be connected to GND as shown in the setup drawing below.

The overvoltage protection clamp level is set to about 24V on DC1309A. The level of the clamp can be changed by replacing the zener diode (D4) with a different zener diode.

The LT3474-1 differs from the LT3474 in the output voltage capabilities. The LT3474 has a 13V clamp that does not allow the use of an LED string of greater than 13V on the output. However, LT3474-1 does not have this clamp and it can power LEDs up to 26V as long as the external clamp is adjusted correctly. High output power can result in excessive heating of the IC. Please read the datasheet for thermal details.

The LT3474-1 datasheet gives a complete description of the part, operation and applications information. The datasheet must be read in conjunction with this Quick Start Guide for DC1309. The LT3474-1 is assembled in a 16-lead plastic TSSOP FE package with a thermally enhanced ground pad. Proper board layout is essential for maximum thermal performance. See the datasheet section 'Layout Hints'.

**Design files for this circuit board are available. Call the LTC factory.**

LT is a registered trademark of Linear Technology Corporation

## QUICK START PROCEDURE

DC1309 is easily set up for evaluating the LT3474-1 step-down 1A LED driver circuit. Follow the test procedure outlined below and see Figure1.

1. Setup DC1309 as shown in Figure 1 with hand-held multimeters, a high-voltage LED string, and a bench supply (power turned off) with voltage greater than the LED string and less than 36V.
2. Turn on the bench power supply and observe a constant 1A through the string of LEDs and high efficiency operation.

3. Use the /SHDN terminal to turn the LEDs on and off by respectively floating or ground the terminal.

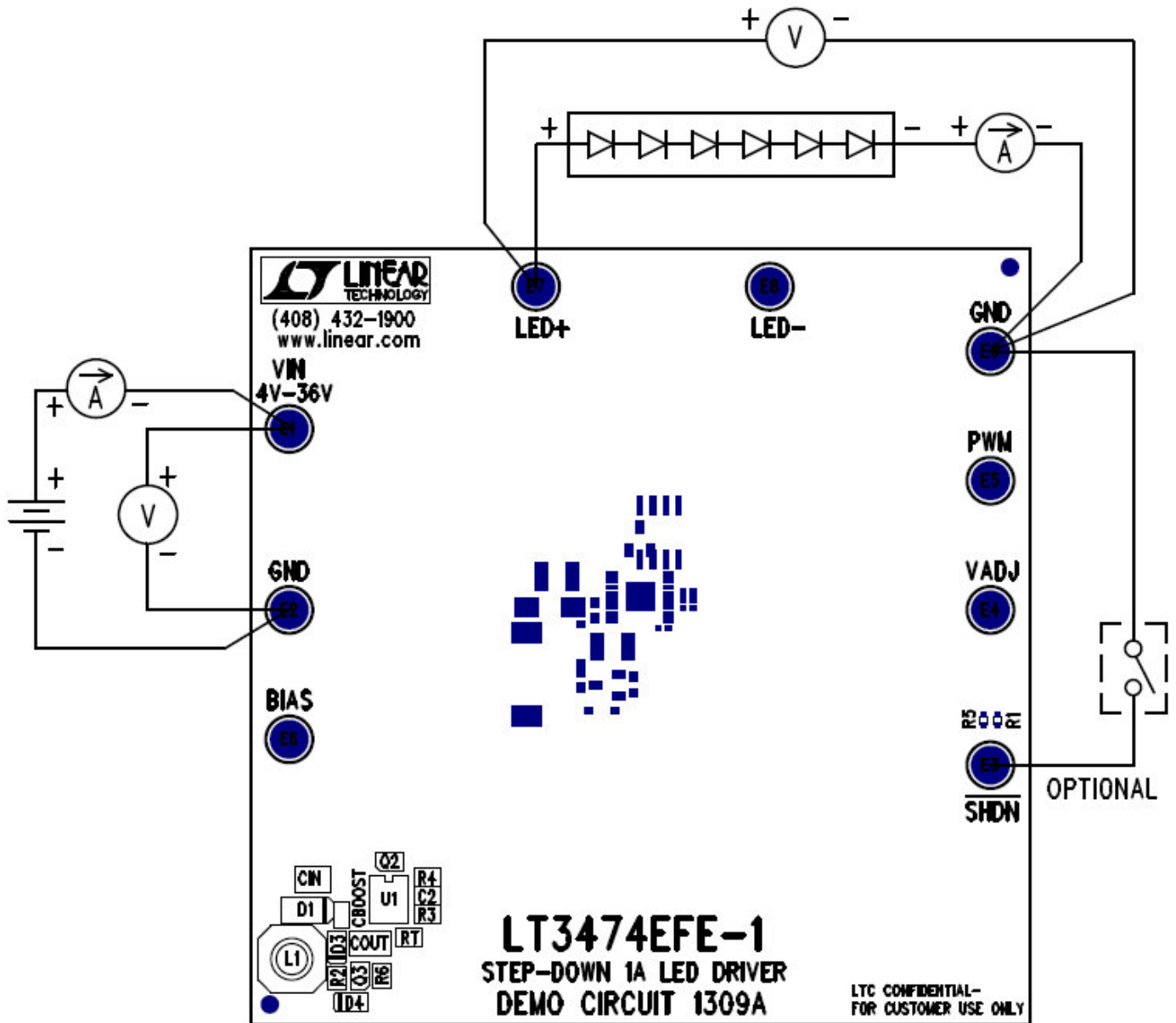
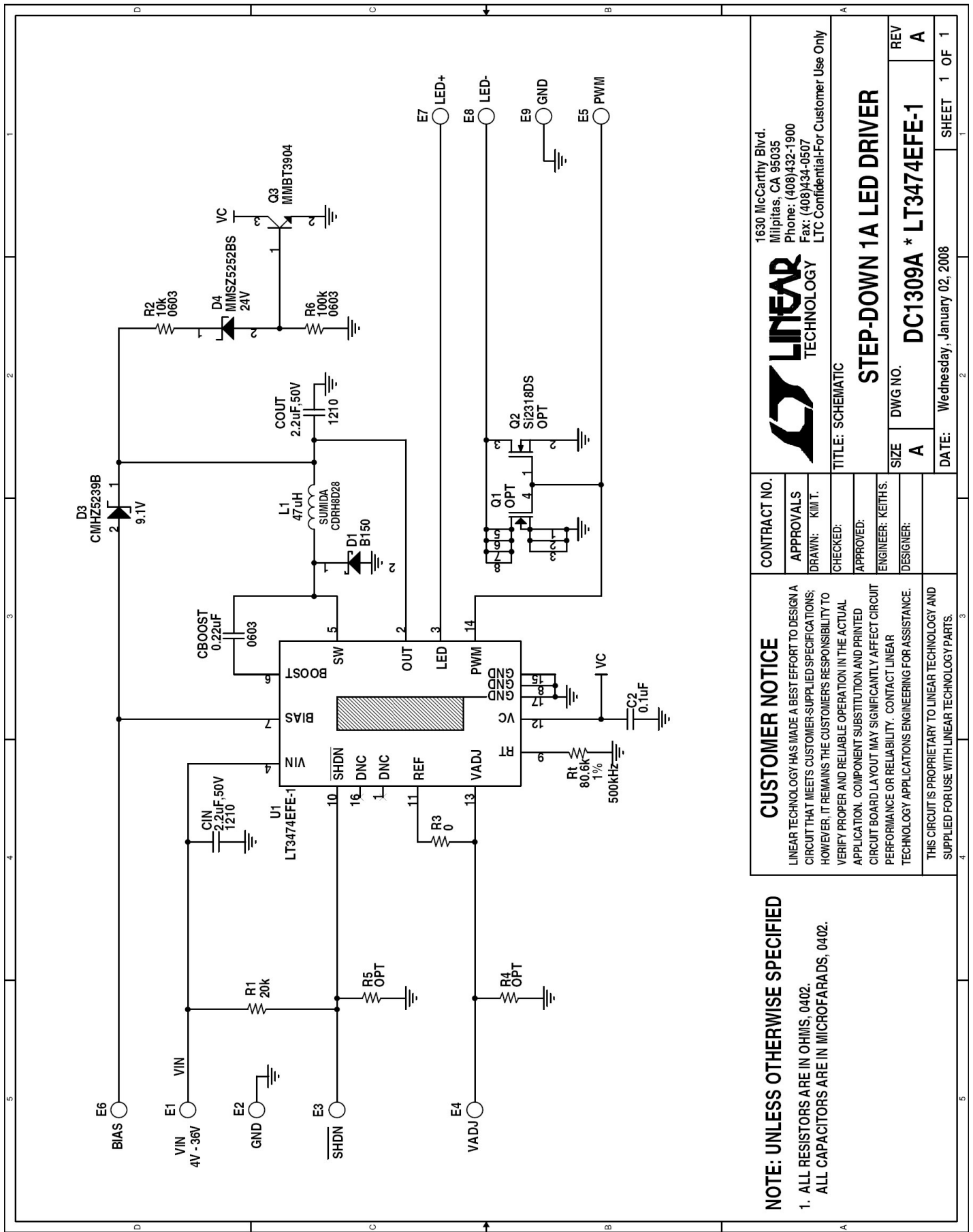

Figure 1. Proper Measurement Equipment Setup

# QUICK START GUIDE FOR DEMONSTRATION CIRCUIT 1309

## STEP-DOWN 1A LED DRIVER



### NOTE: UNLESS OTHERWISE SPECIFIED

1. ALL RESISTORS ARE IN OHMS, 0402.  
ALL CAPACITORS ARE IN MICROFARADS, 0402.

### CUSTOMER NOTICE

LINEAR TECHNOLOGY HAS MADE A BEST EFFORT TO DESIGN A CIRCUIT THAT MEETS CUSTOMER-SUPPLIED SPECIFICATIONS; HOWEVER, IT REMAINS THE CUSTOMER'S RESPONSIBILITY TO VERIFY PROPER AND RELIABLE OPERATION IN THE ACTUAL APPLICATION. COMPONENT SUBSTITUTION AND PRINTED CIRCUIT BOARD LAYOUT MAY SIGNIFICANTLY AFFECT CIRCUIT PERFORMANCE OR RELIABILITY. CONTACT LINEAR TECHNOLOGY APPLICATIONS ENGINEERING FOR ASSISTANCE.

THIS CIRCUIT IS PROPRIETARY TO LINEAR TECHNOLOGY AND SUPPLIED FOR USE WITH LINEAR TECHNOLOGY PARTS.

### CONTRACT NO.

APPROVALS  
DRAWN: KIM T.

CHECKED:

APPROVED:

ENGINEER: KEITH S.

DESIGNER:

1630 McCarthy Blvd.  
Milpitas, CA 95035  
Phone: (408)432-1900  
Fax: (408)434-0507  
LTC Confidential-For Customer Use Only



TITLE: SCHEMATIC

### STEP-DOWN 1A LED DRIVER

SIZE DWG NO. DC1309A \* LT3474EFE-1

REV A

DATE: Wednesday, January 02, 2008

SHEET 1 OF 1

## Данный компонент на территории Российской Федерации

### Вы можете приобрести в компании MosChip.

Для оперативного оформления запроса Вам необходимо перейти по данной ссылке:

<http://moschip.ru/get-element>

Вы можете разместить у нас заказ для любого Вашего проекта, будь то серийное производство или разработка единичного прибора.

В нашем ассортименте представлены ведущие мировые производители активных и пассивных электронных компонентов.

Нашей специализацией является поставка электронной компонентной базы двойного назначения, продукции таких производителей как XILINX, Intel (ex.ALTERA), Vicor, Microchip, Texas Instruments, Analog Devices, Mini-Circuits, Amphenol, Glenair.

Сотрудничество с глобальными дистрибьюторами электронных компонентов, предоставляет возможность заказывать и получать с международных складов практически любой перечень компонентов в оптимальные для Вас сроки.

На всех этапах разработки и производства наши партнеры могут получить квалифицированную поддержку опытных инженеров.

Система менеджмента качества компании отвечает требованиям в соответствии с ГОСТ Р ИСО 9001, ГОСТ РВ 0015-002 и ЭС РД 009

### Офис по работе с юридическими лицами:

105318, г.Москва, ул.Щербаковская д.3, офис 1107, 1118, ДЦ «Щербаковский»

Телефон: +7 495 668-12-70 (многоканальный)

Факс: +7 495 668-12-70 (доб.304)

E-mail: [info@moschip.ru](mailto:info@moschip.ru)

Skype отдела продаж:

moschip.ru

moschip.ru\_4

moschip.ru\_6

moschip.ru\_9