

## SPECIFICATION

- Part No. : **AGGBP.25B.07.0060A**
- Description : 25x25mm Two Stage GPS-GLONASS-GALILEO-BeiDou Embedded Active Patch Antenna Module with Front-End SAW Filter
- Features : Full GPS-GLONASS-GALILEO-BeiDou Coverage  
28dB two stage LNA  
Ceramic patch Element  
Front-end SAW filter to reduce out of band noise  
Wide input voltage 1.8V to 5.5V  
25.1 x 25.1 x 7.9mm  
60mm Ø1.13 IPEX MHFI (U.FL)  
Automotive TS16949 Production and Quality Approved  
Cable length and connector type customizable  
**RoHS Compliant**



# 1. Introduction

The AGGBP.25B is an internal GPS/GLONASS/GALILEO/BeiDou active patch antenna with Ø1.13 cable and IPEX MHFI connector. It is the ideal antenna for next generation GNSS devices to achieve good sensitivity across all bands in a small form factor.

The active patch antenna, by means of a double resonance design, has a wide-band operation over GPS/GLONASS/GALILEO/BeiDou systems from 1561MHz to 1606MHz. It includes a two-stage LNA and front-end SAW filter to reduce out of band noise, such as from nearby cellular transceivers. This antenna offers better protection from nearby radiated power surges and greatly reduces the probability of damaging your GPS/GLONASS/BeiDou receiver due to nearby transmissions.

The patch, the ground plane, the LNA, and front-end SAW components are all integrated in a dimension of 25.1 x 25.1 x 7.9 mm, connecting with a Ø1.13 60mm long coaxial cable and an IPEX MHFI connector. The AGGBP.25B is manufactured and tested in a TS16949 first tier automotive approved facility. The cable length and connector type can be adjusted for a MOQ.

For further optimization to customer specific device environments, custom tuned patch antennas can be supplied, again to a MOQ. For more details please contact your regional Taoglas sales office.

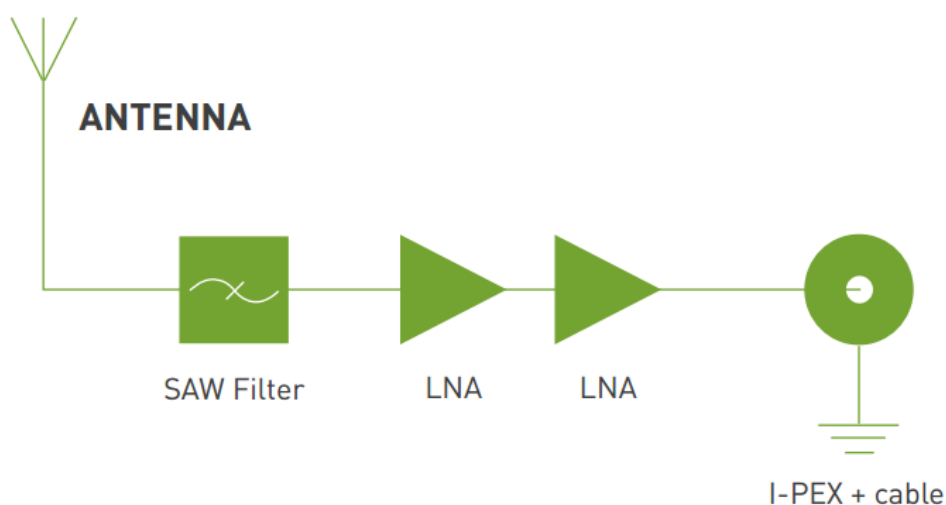

## 2. Specification

### 2.1 Patch Antenna

ELECTRICAL	
Frequency	GPS: 1575.42 ± 1.023MHz Galileo: 1575.42 ± 4GHz GLONASS: 1602 ± 5MHz BEIDOU: 1561.098 ± 2.046MHz.
Polarization	RHCP
Antenna Gain at Zenith (Ceramic Patch only)	GPS/Galileo: -2.5 dBi typ. @zenith GLONASS: -1.5 dBi typ. @zenith BEIDOU: -1 dBi typ. @zenith
Total Antenna Gain at Zenith (Antenna+SAW+LNA+ Cable+Connector)	GPS/Galileo 1575.42MHz: 25.5 ± 3dBi GLONASS 1602MHz: 26 ± 3dBi BEIDOU 1561MHz: 27 ± 3dBi
Impedance	50 ohms
Output VSWR	Max 2.0
MECHANICAL	
Ceramic Dimension	25.1 x 25.1 x 4.7mm
Total Dimension (including shielding case)	25.1 x 25.1 x 7.9mm
Connector	IPEX MHFI (U.FL)
Cable	coaxial cable Ø1.13, length 60mm
Weight (g)	11.46
ENVIRONMENTAL	
Operation Temperature	-40°C to 85°C
Storage Temperature	-40°C to + 85°C
Humidity	Non-condensing 65°C 95% RH

## 2.1 LNA

ELECTRICAL			
Frequency	1558~1610 MHz.		
Out of Band Attenuation	0-1534MHz, 13dB Min. 1634MHz-6000MHz, 20dB Min.		
Output Impedance	50Ω		
Output VSWR	2.0 Max		
Pout at 1dB Gain	-6 dBm Min.		
Compression Point	-2 dBm Typical		
LNA Gain, Power Consumption and Noise Figure			
Voltage	LNA Gain(Typ)	Power Consumption(mA) Typ	Noise Figure (Typ)
Min 1.8V	22dB	5mA	3.0dB
Typ 3.0V	28dB	10mA	2.8dB
Max 5.5V	31dB	23mA	3.0dB

### 3. LNA Gain and Noise Figure @3.0V

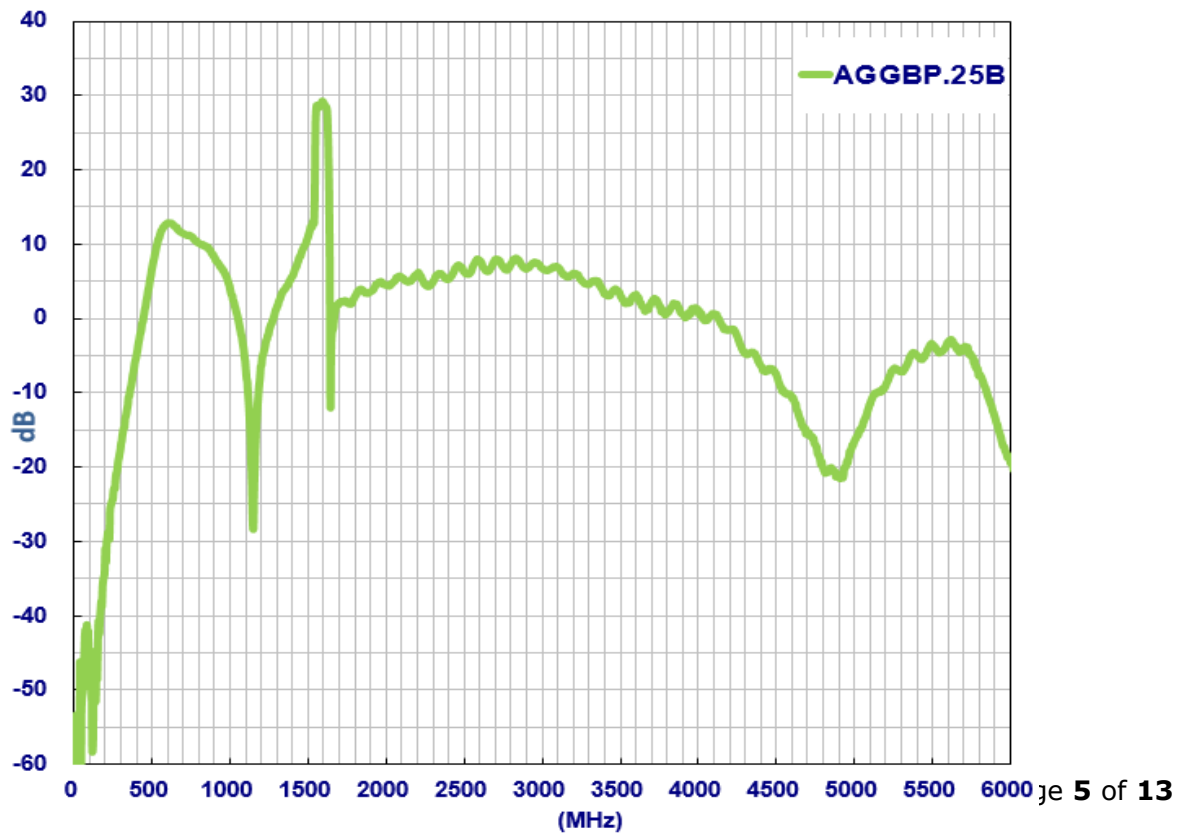
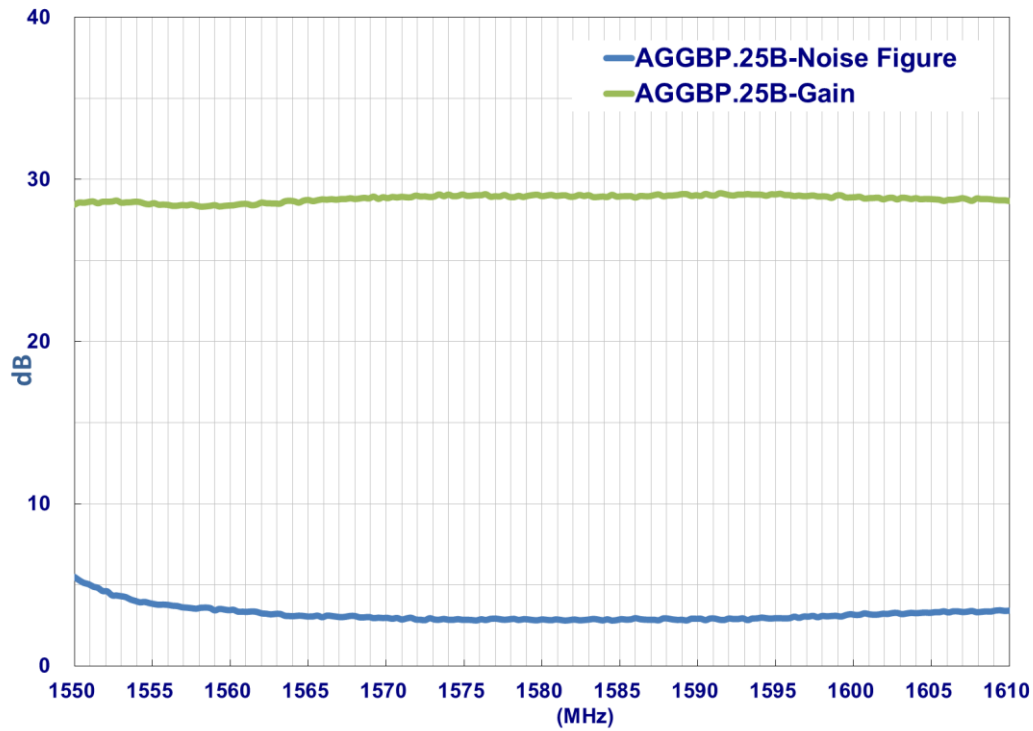

## 4. Antenna Return Loss

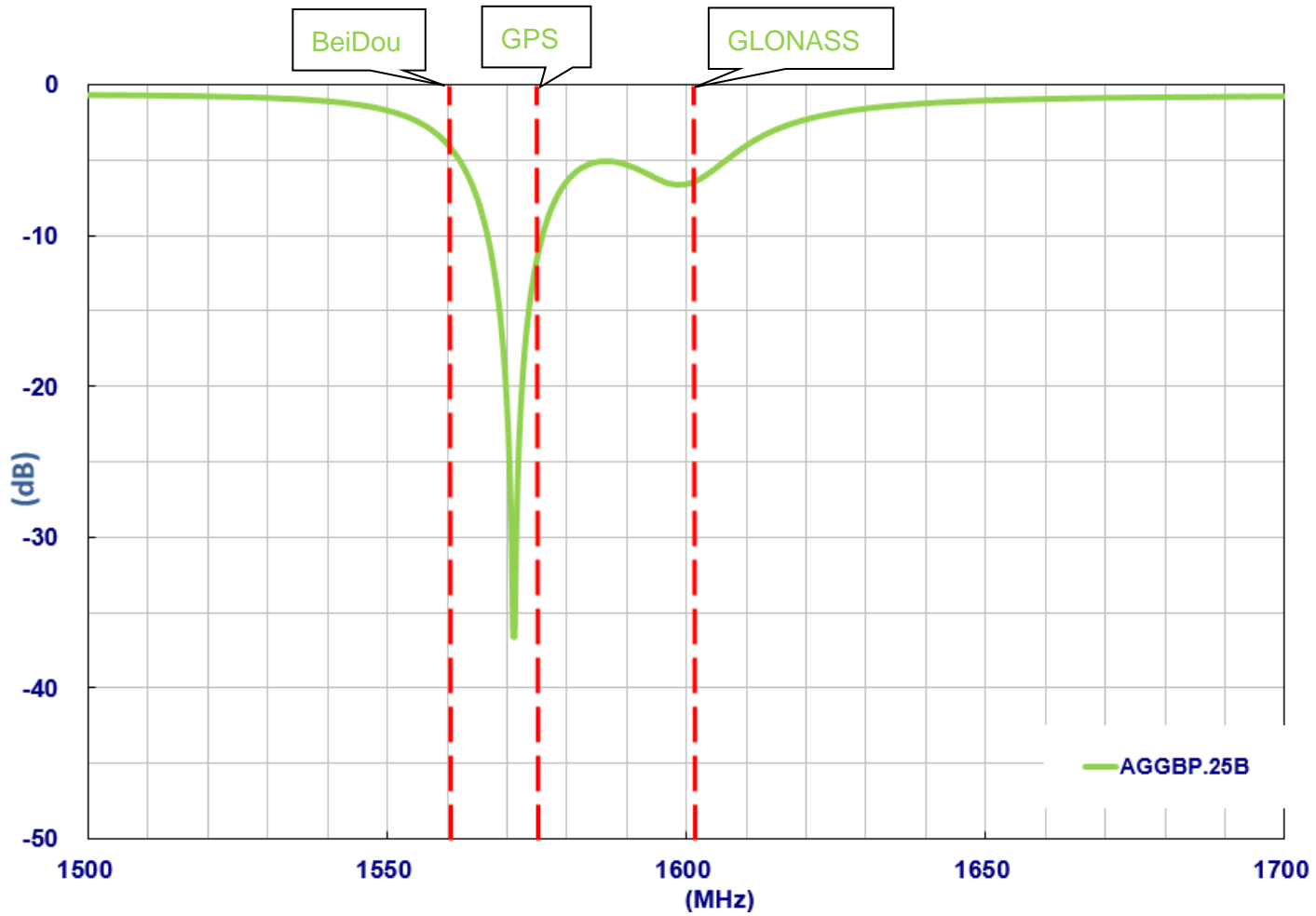

## 5. Antenna Radiation Properties

### 5.1 Test Setup

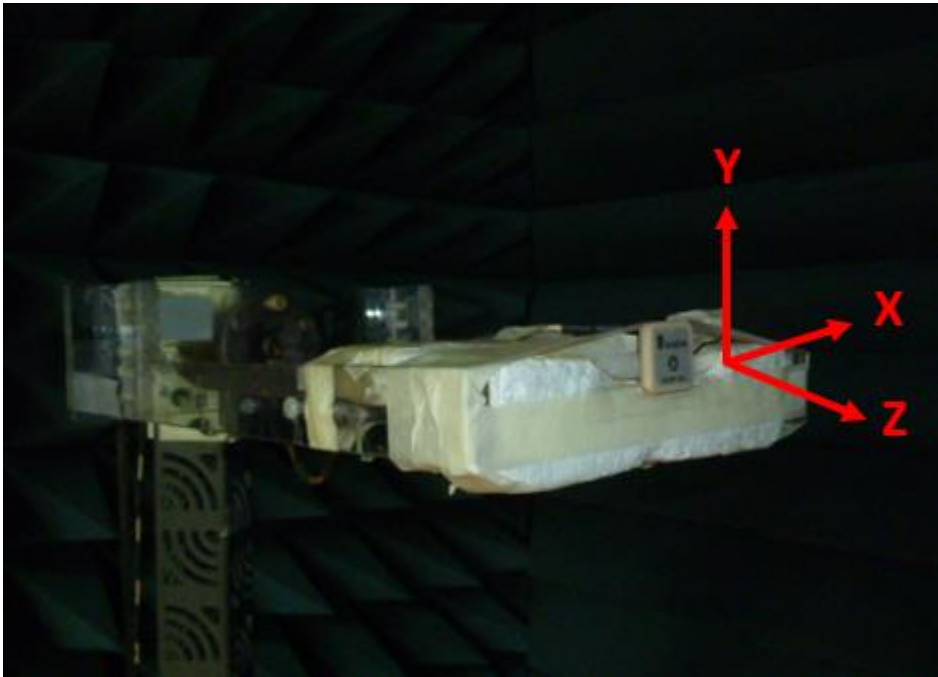

## 5.2 2D Radiation Pattern

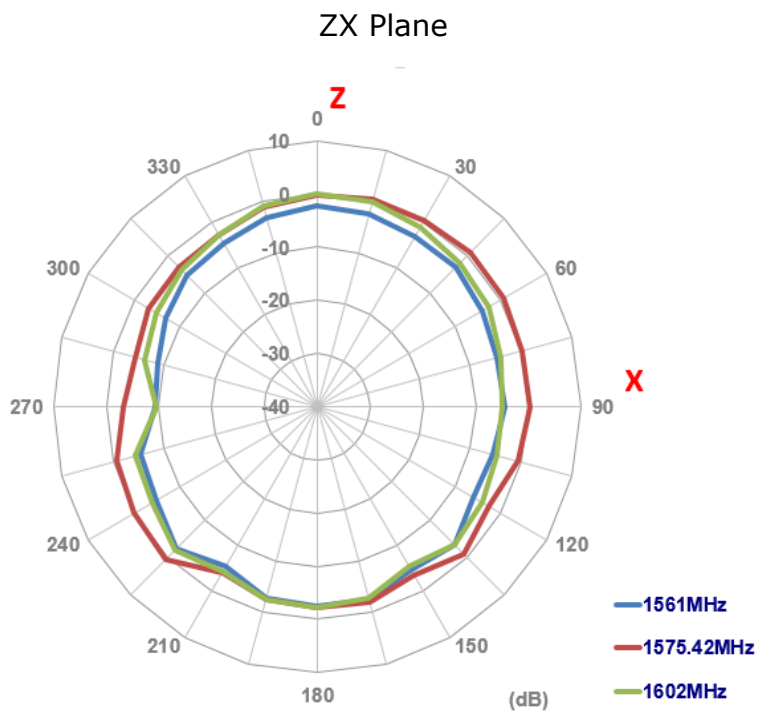
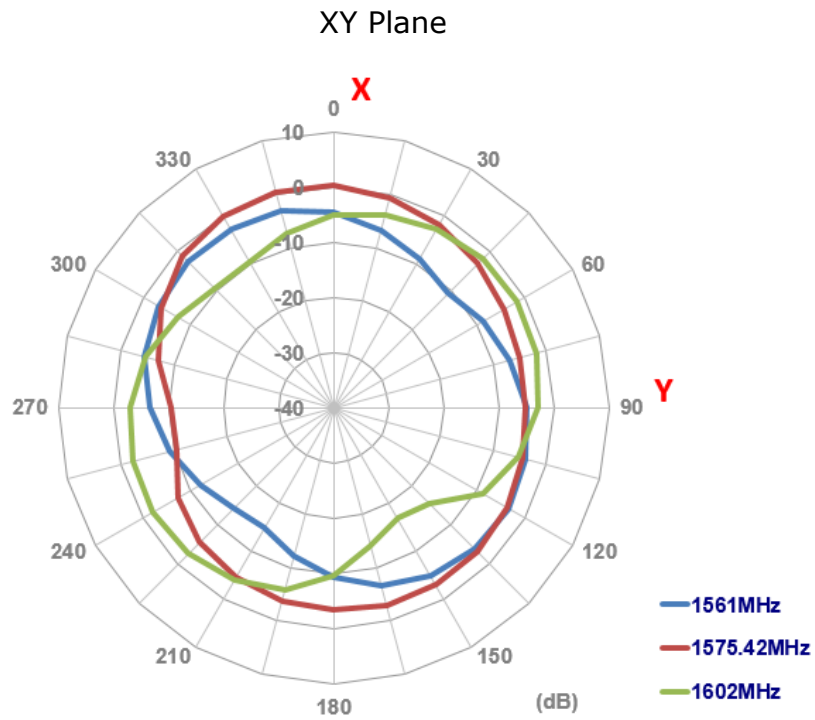



YZ Plane

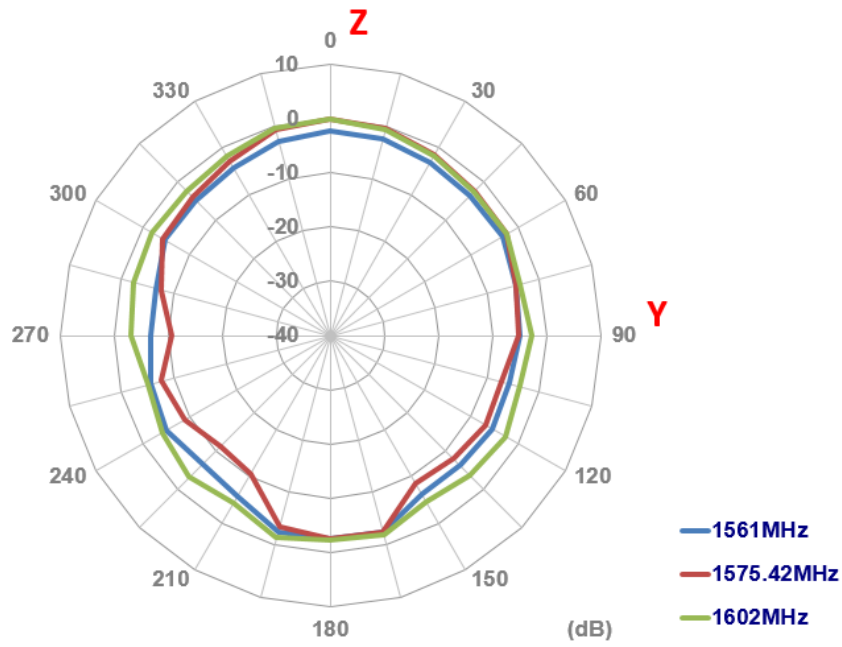

### 5.3 3D Radiation Pattern

1561MHz

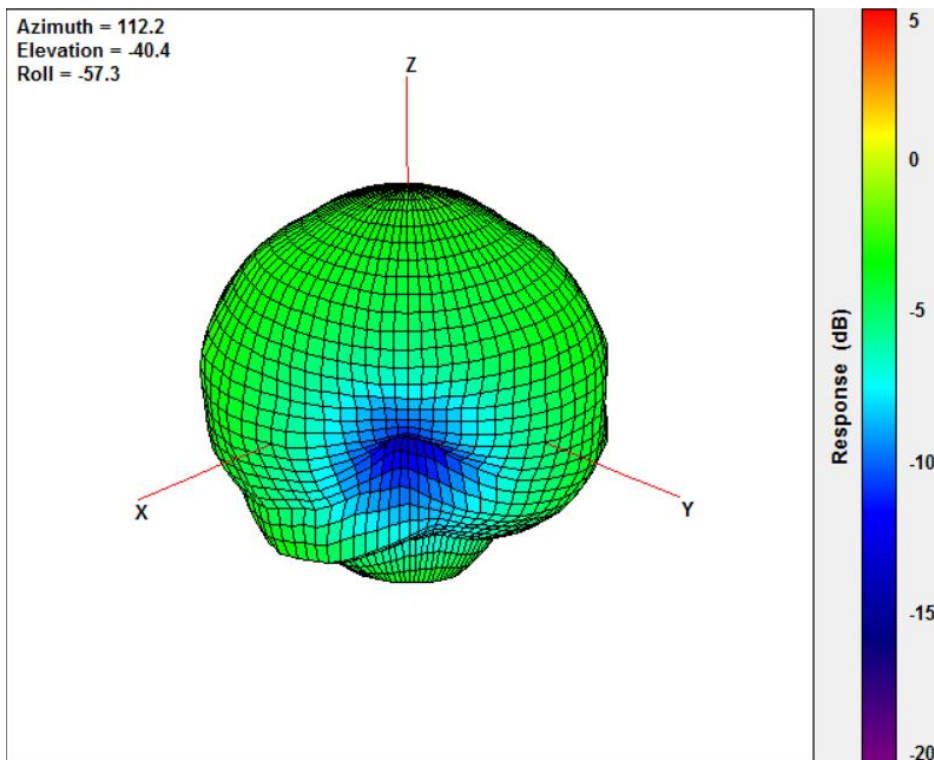



1575.42MHz

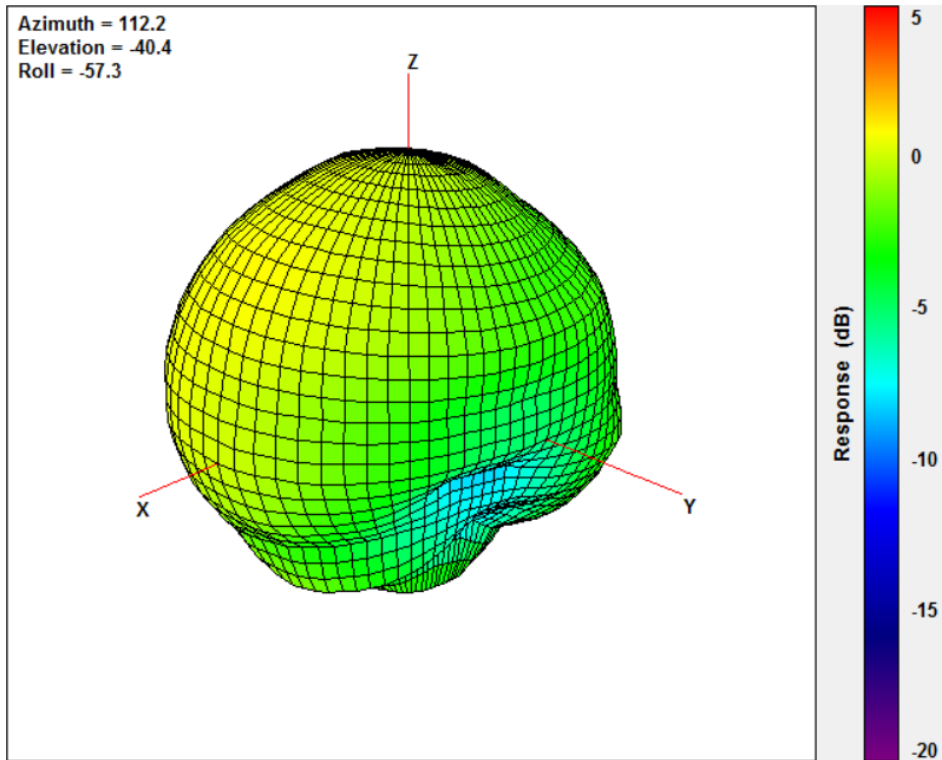

1602MHz

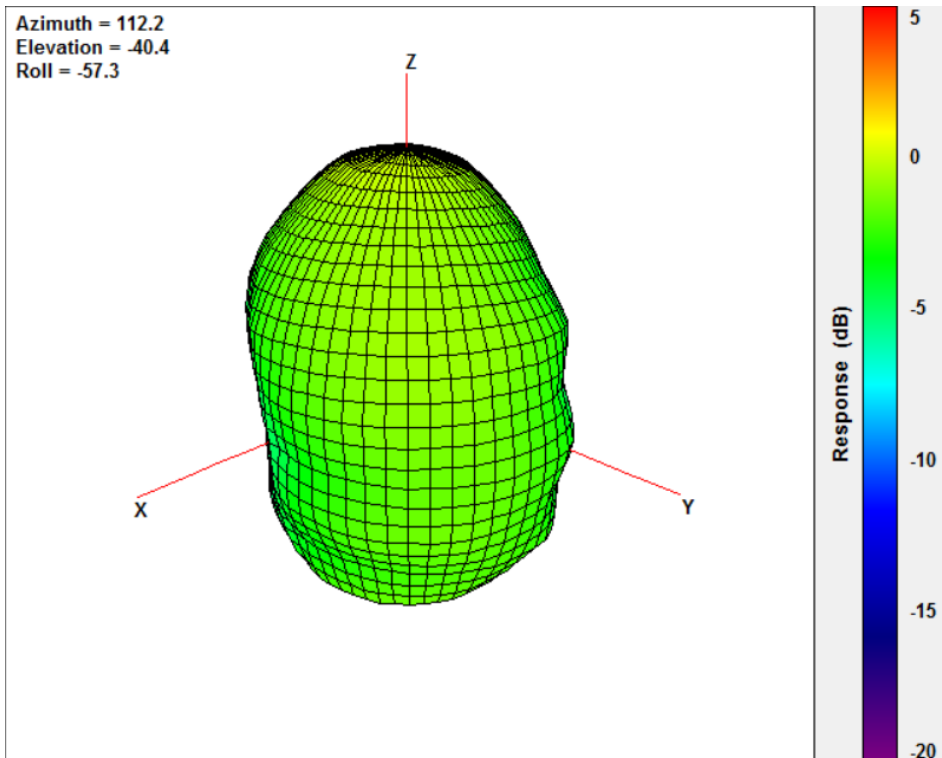

## 6. Plugs Usage Precautions

### Mating / unmating

(1) To disconnect connectors, insert the end portion of I-PEX under the connector flanges and pull off vertically, in the direction of the connector mating axis.

(2) To mate the connectors, the mating axes of both connectors must be aligned and the connectors can be mated. The "click" will confirm fully mated connection.

Do not attempt to insert on an extreme angle.

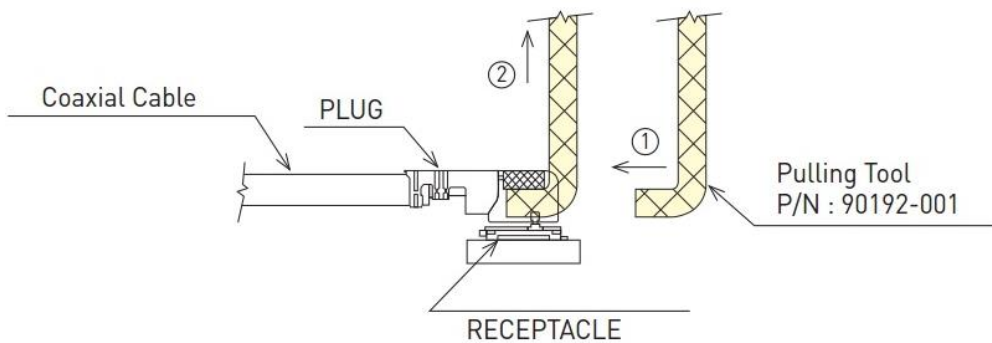

### Pull forces on the cable after connectors are mated

After the connectors are mated, do not apply a load to the cable in excess of the values indicated in the diagram below.

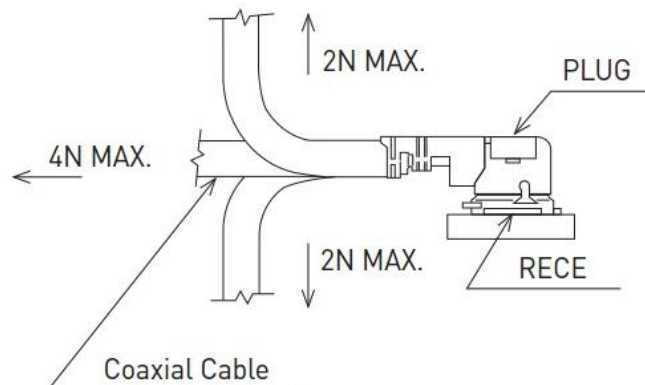

## 7. Mechanical Drawing (Unit: mm)

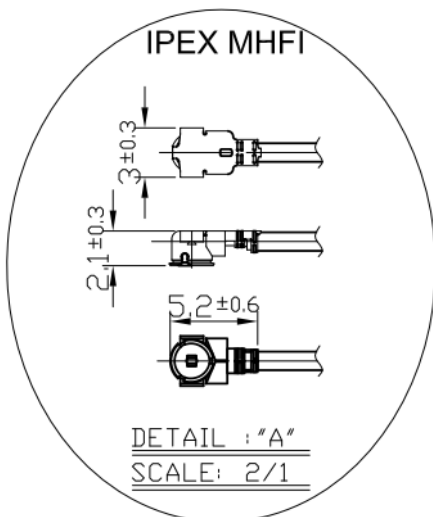
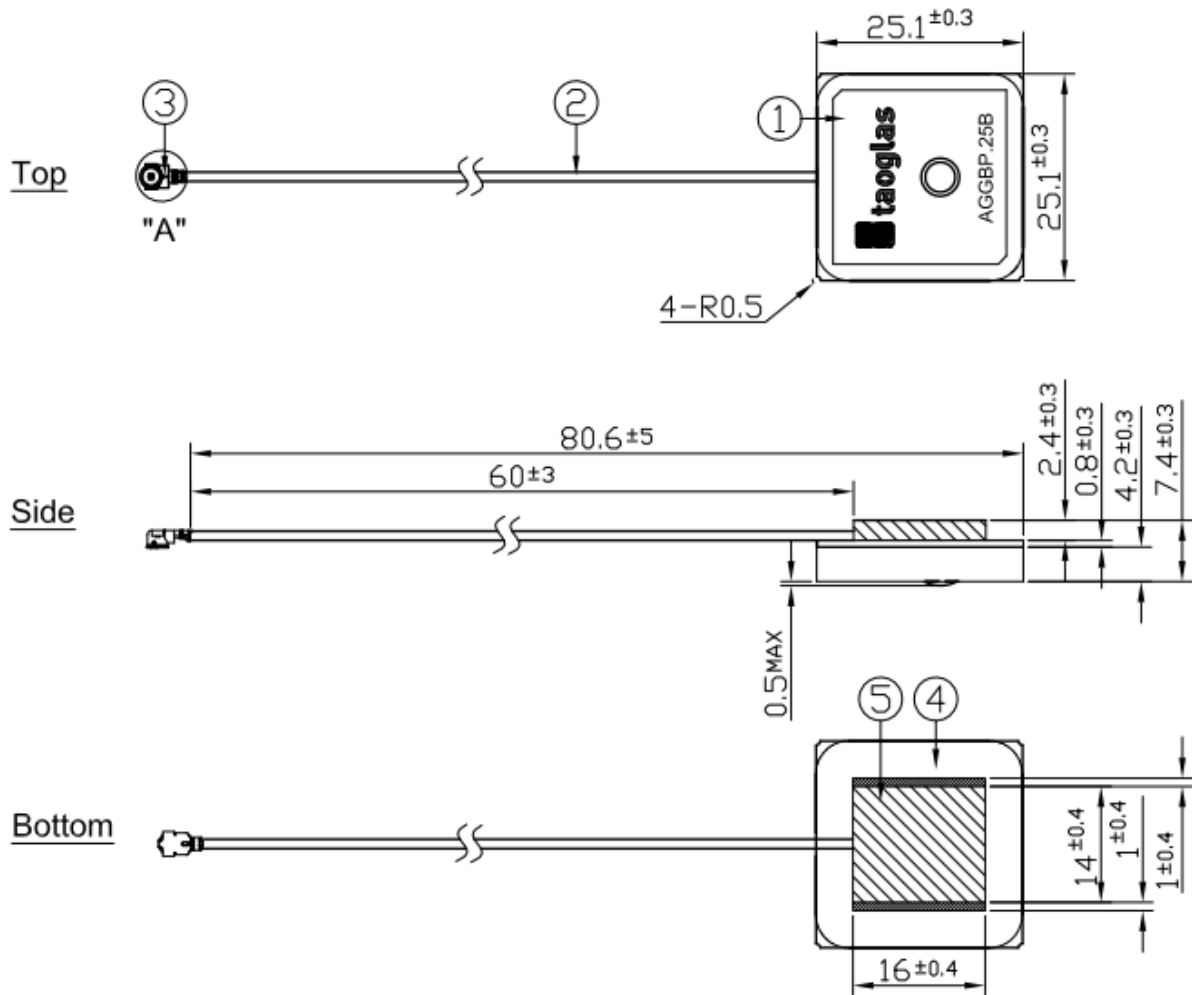

	Name	Material	Finish	QTY
1	Patch (25*25*4mm)	Ceramic	Clear	1
2	1.13 Coaxial Cable	FEP	Gray	1
3	IPEX MHF1	Brass	Gold	1
4	PCB	FR4 0.8t	Green	1
5	Shielding Case	(Tin)SPTE	Tin Plated	1

Unit:mm

## 8. Packaging

### Packaging Specifications

30 pcs per tray  
 5 Trays per PE bag  
 Tray Dimensions - 370\*305\*25mm  
 Weight - 421g

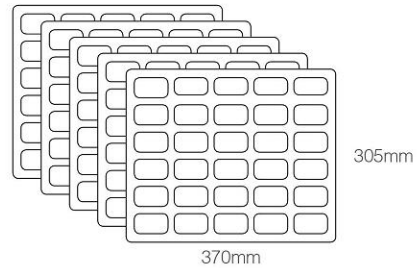

5 Trays per Carton - 150 pcs  
 Carton Dimensions - 390\*320\*290mm

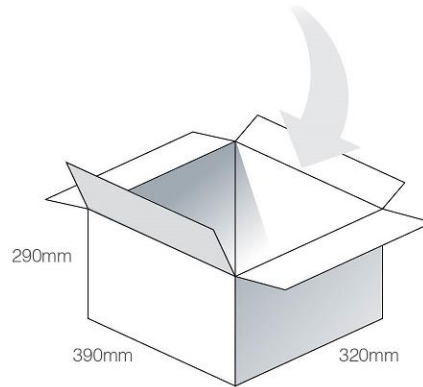

Pallet Dimensions 1100\*1100\*1310mm  
 24 Cartons per Pallet  
 4 Cartons per layer  
 6 Layers

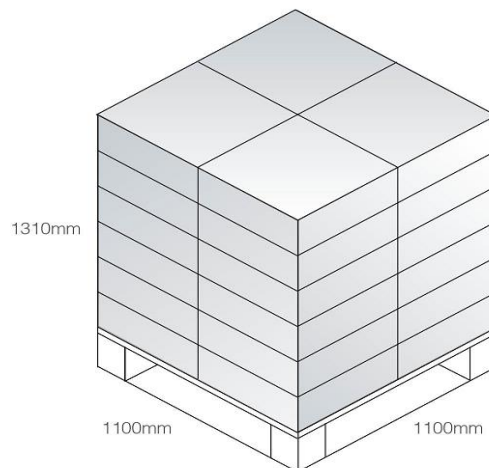

Taoglas makes no warranties based on the accuracy or completeness of the contents of this document and reserves the right to make changes to specifications and product descriptions at any time without notice. Taoglas reserves all rights to this document and the information contained herein.

Reproduction, use or disclosure to third parties without express permission is strictly prohibited.

Copyright © Taoglas Ltd.

## Данный компонент на территории Российской Федерации

### Вы можете приобрести в компании MosChip.

Для оперативного оформления запроса Вам необходимо перейти по данной ссылке:

<http://moschip.ru/get-element>

Вы можете разместить у нас заказ для любого Вашего проекта, будь то серийное производство или разработка единичного прибора.

В нашем ассортименте представлены ведущие мировые производители активных и пассивных электронных компонентов.

Нашей специализацией является поставка электронной компонентной базы двойного назначения, продукции таких производителей как XILINX, Intel (ex.ALTERA), Vicor, Microchip, Texas Instruments, Analog Devices, Mini-Circuits, Amphenol, Glenair.

Сотрудничество с глобальными дистрибьюторами электронных компонентов, предоставляет возможность заказывать и получать с международных складов практически любой перечень компонентов в оптимальные для Вас сроки.

На всех этапах разработки и производства наши партнеры могут получить квалифицированную поддержку опытных инженеров.

Система менеджмента качества компании отвечает требованиям в соответствии с ГОСТ Р ИСО 9001, ГОСТ РВ 0015-002 и ЭС РД 009

### Офис по работе с юридическими лицами:

105318, г.Москва, ул.Щербаковская д.3, офис 1107, 1118, ДЦ «Щербаковский»

Телефон: +7 495 668-12-70 (многоканальный)

Факс: +7 495 668-12-70 (доб.304)

E-mail: [info@moschip.ru](mailto:info@moschip.ru)

Skype отдела продаж:

moschip.ru

moschip.ru\_4

moschip.ru\_6

moschip.ru\_9