

HWB60-AL SEALED POWER DISTRIBUTION MODULE

Compact Hard-Wired PDM for 280 Style Components



Specifications Overview

Max Fuse Rating:	30A per circuit
Max Continuous Current:	250A
Number of Cavities	60
Mounting Torque:	4-6 Nm
Operating Temp:	See page 2 for temperature ratings
Ingress Protection:	IP67/IP68/IP69K
Material:	Body & Cover: UL94-V0 TPA: UL94-V0 Gasket: Silicone
Corrosion Test:	96 hours - salt spray test to ASTM standard
Vibration and Shock Test:	SAE J1455

Features and Benefits

- AssureLatch™ yellow positive-sealing latches keep the cover securely in place while allowing for fast service.
- Accepts any mini (280 style) circuit protection component.
- Compact size allows the unit to be installed in vehicles with limited space.
- Ideal for accessory circuits, overflow circuits from main PDM, or as a main module on smaller vehicles.
- IP67/IP68/IP69K sealed units can be installed in many locations on the vehicle and stand up to road splash and salt spray.
- TPAs (terminal position assurance locks) give secondary locking protection of the wire leads, which help keeps leads securely in place.
- Wires plug into the back of the unit using industry-standard Delphi Metri-Pack Series 280 tanged terminals.
- Multiple units can be dovetailed together to expand capacity. They can also be interlocked to other Littelfuse PDMs and fuse holders. (FLEC, Flex-MEGA, Flex-MIDI).
- Add-on accessory can hold a fuse puller and spare fuses.
- Tethers available to prevent loss of cover during service.
- Optional grid on inside cover available; functions as relay retention insert
- High Temperature Gore Vent allows for max operating temp to increase from 85°C to 125°C. High Temperature Gore Vents allow for heat and pressure to be expelled, while maintaining IP Ratings.

Description

The HWB60-AL Hard-Wired Box is the perfect fit for accessory circuits and overflow circuits from your main PDM. For smaller vehicles, this unit is an ideal solution as a main vehicle module. It features durable construction, an IP-rated housing, and a compact size. The additional vent assures sealing up to 125°C. The user can customize their own circuitry utilizing direct wire-to-component connections.

Applications

- Accessory Circuits
- Overflow Circuits
- Primary on Small Vehicles

Ordering Information

PART NUMBER	AssureLatch™		GRID	HIGH TEMP (VENTED)	IP RATING
	FINGER	TOOL			
PDM71001ZXM		•			IP67/69K
PDM71003ZXM	•				IP67/69K
PDM71004ZXM		•	•		IP67/69K
PDM71006ZXM		•		•	IP68/69K
PDM71008ZXM	•			•	IP68/69K
PDM71009ZXM		•	•	•	IP68/69K

Web Resources

Download 2D print and technical resources at:
littelfuse.com/HWB60-AL

Accessories and Service Parts

PART NUMBER	DESCRIPTION
868-055	Base (non-vented)
873-018	Cover
901-323	Gasket
883-083	TPA (6 needed per assembly)
873-680	Optional Tether
901-322	Grid

HWB60-AL SEALED POWER DISTRIBUTION MODULE

Specifications

Max Fuse Rating	30A per circuit
Max Continuous Current	250A
Number of Cavities	60
Recommended Mounting	M6 bolt and lock washer
Mounting Torque	4-6 Nm
Temperature Range	PDM71001ZXM, PDM71003ZXM, PDM71004ZXM: -40 °C to +85 °C PDM71006ZXM, PDM71008ZXM, PDM71009ZXM: -40 °C to +125 °C
Ingress Protection Rating	PDM71001ZXM, PDM71003ZXM, PDM71004ZXM: IP67/69K PDM71006ZXM, PDM71008ZXM, PDM71009ZXM: IP68/69K
Dimensions	158 x 66 x 79 mm
Labels	Consult Littelfuse for label options
Wire Sizes	0.35-5.00 mm ²
Mating Terminals & Seals	Delphi Metri-Pack 280 Sealed female (tanged). Sold separately. See chart below for details. Terminal featured in plastic housing to prevent misinsertion.
Accessories	Optional: Cover tether, relay retention insert, custom footprint label

Mating Terminals and Seals Compatibility

Wire Size Range (mm ²)	Insulation Diameter (mm)	Terminal	Cable Seal	Cable Plug
0.50-0.35 mm ²	1.70-1.29 mm ²	12084201	12034365/15324983	12010300
1.00-0.50 mm ²	2.15-1.60 mm ²	12077411	12089444/15324985	12010300
2.00-1.00 mm ²	2.85-2.03 mm ²	15363933	12015284/15324982	12010300
3.00-2.00 mm ²	3.49-2.81 mm ²	12129493	12015359/15324980	12010300
3.0-5.0 mm ²	4.30-3.45 mm ²	12077413	12015360/15324981	12010300

Sold separately. Available from Delphi.

Dimensions in millimeters

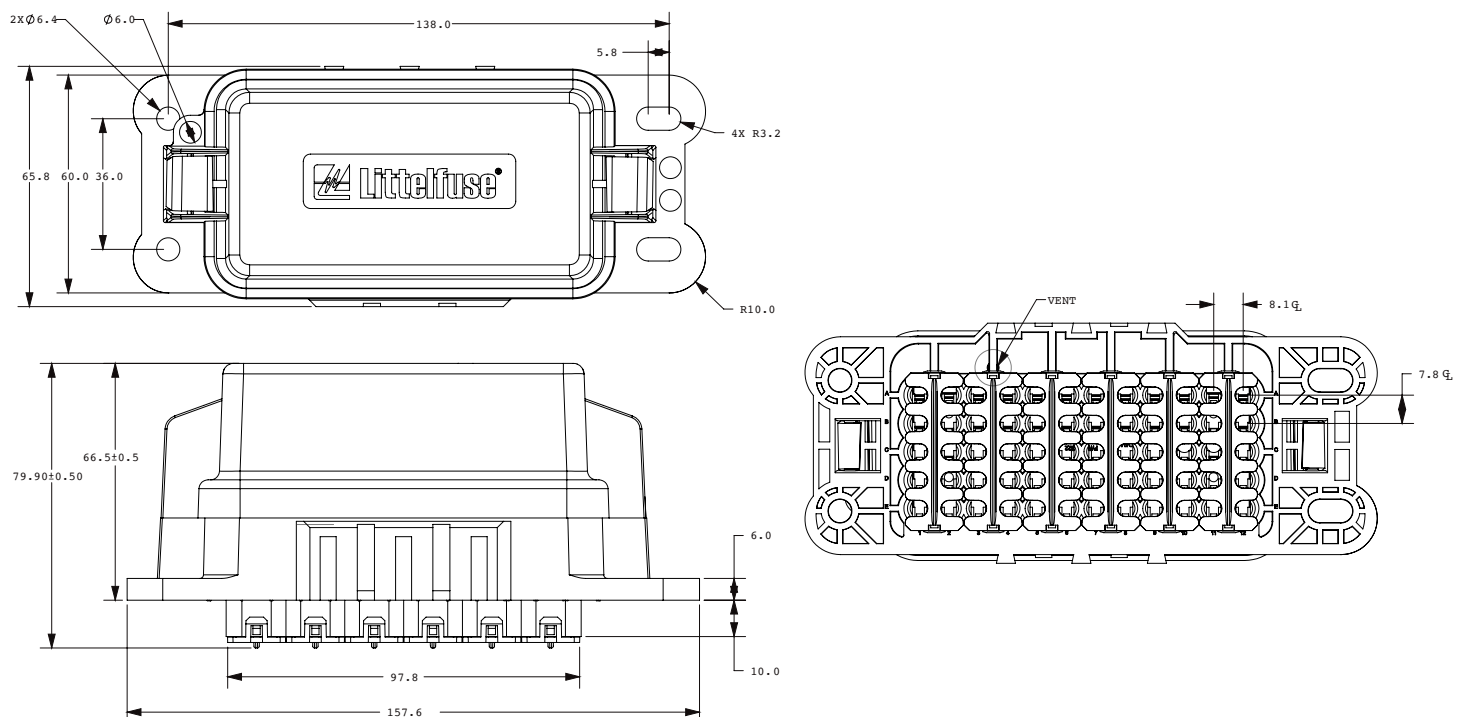

Данный компонент на территории Российской Федерации

Вы можете приобрести в компании MosChip.

Для оперативного оформления запроса Вам необходимо перейти по данной ссылке:

<http://moschip.ru/get-element>

Вы можете разместить у нас заказ для любого Вашего проекта, будь то серийное производство или разработка единичного прибора.

В нашем ассортименте представлены ведущие мировые производители активных и пассивных электронных компонентов.

Нашей специализацией является поставка электронной компонентной базы двойного назначения, продукции таких производителей как XILINX, Intel (ex.ALTERA), Vicor, Microchip, Texas Instruments, Analog Devices, Mini-Circuits, Amphenol, Glenair.

Сотрудничество с глобальными дистрибьюторами электронных компонентов, предоставляет возможность заказывать и получать с международных складов практически любой перечень компонентов в оптимальные для Вас сроки.

На всех этапах разработки и производства наши партнеры могут получить квалифицированную поддержку опытных инженеров.

Система менеджмента качества компании отвечает требованиям в соответствии с ГОСТ Р ИСО 9001, ГОСТ РВ 0015-002 и ЭС РД 009

Офис по работе с юридическими лицами:

105318, г.Москва, ул.Щербаковская д.3, офис 1107, 1118, ДЦ «Щербаковский»

Телефон: +7 495 668-12-70 (многоканальный)

Факс: +7 495 668-12-70 (доб.304)

E-mail: info@moschip.ru

Skype отдела продаж:

moschip.ru

moschip.ru_4

moschip.ru_6

moschip.ru_9