

SM Beads (Common-Mode)

Surface mount common-mode beads are available from Fair-Rite in several materials and sizes. The common-mode bead provides a common magnetic path for the flux generated by the current to the load and the return current from the load. The current compensation results in zero magnetic flux in the bead.

- SM Beads on 12mm tape width are supplied taped and reeled per EIA 481-1 and IEC 60286-3 standards. SM Beads on 16 and 24 mm tape widths are supplied taped and reeled per EIA 481-2 and IEC 60286-3 standards. Taped and reeled parts are supplied on a 13" reel.
- SM Beads can also be supplied not taped and reeled and then are bulk packed. This packing method will change the last digit of the part number to a "6".
- The copper conductors have a lead-free tin coating. If required SM Beads can be supplied with copper conductors having a tin/lead coating. See page 28 for suggested solder profile for lead-free components.
- SM Beads meet the solderability specifications when tested in accordance with MIL-STD-202, method 208. After dipping the mounting site of the bead, the solder surface shall be at least 95% covered with a smooth solder coating. The edges of the copper strip are not specified as solderable surfaces.
- After preheating the beads to within 100 °C of the soldering temperature, the parts meet the resistance to soldering requirements of EIA-186-10E, temperature 260±5 °C and time 10±1 seconds.
- Suggested land patterns are in accordance with the latest revision of IPC-7351.
- SM Beads are controlled for impedance limits only. The impedances listed are typical values. Minimum impedance values are specified for the + marked frequencies.
The minimum guaranteed impedance is the listed value less 20%.
SM Beads in 44 materials are measured for impedance on the 4193 Vector Impedance Analyzer. The 52 SM Beads are tested for impedance on the 4191A RF Impedance Analyzer.
- Recommended storage and operation temperature is -55 °C to 125 °C.
- The maximum current rating for these SM Beads is 5 amps.
- Performance curves of all the SM Beads are compiled on the Fair-Rite Products CD-ROM.
- For any SM Bead requirement not listed, please contact our customer service group for availability and pricing.
- Our "Surface Mount Bead Kit" (part number 0199000025) is available for prototype evaluation. See page 67.
- Explanation of Part Numbers: Digits 1&2 = product class, 3&4 = material grade, last digit 6 = bulk packed, 7 = taped and reeled.

Fair-Rite Products Corp. PO Box J, One Commercial Row, Wallkill, NY 12589-0288

Phone: (888) FAIR RITE / (845) 895-2055 • FAX: (888) FERRITE / (845) 895-2629 • www.fair-rite.com
(888) 324-7748 (888) 337-7483 • E-Mail: ferrites@fair-rite.com

SM Beads (Common-Mode)

Broadband Frequencies 10-300 MHz (44 material)

Dimensions (Bold numbers are in millimeters, light numbers are nominal in inches.)

Part Number	Fig.	A	B	C	D	E	Wt (g)	Tape Width mm	Pitch mm	Parts/Reel
2744041447	1	2.85±0.2 .112	5.6±0.2 .220	5.0 - 0.6 .185	1.35±0.5 .053	2.54±0.1 .100	.30	12	8	2400
2744045447	1	2.85±0.2 .112	5.6±0.2 .220	8.9 - 0.8 .335	1.35±0.5 .053	2.54±0.1 .100	.53	16	8	2400
2744051447	2	4.5 Max. .177 Max.	6.65 Max. .262 Max.	12.0 Max. .472 Max.	2.5±0.5 .098	3.00±0.1 .118	1.0	24	12	1000
2744065447	2	5.3 Max. .209 Max.	7.00 Max. .275 Max.	14.8 Max. .582 Max.	2.5±0.5 .098	3.00±0.1 .118	1.8	24	12	1000

Higher Frequencies 250-1000 MHz (52 material)

Part Number	Fig.	A	B	C	D	E	Wt (g)	Tape Width mm	Pitch mm	Parts/Reel
2752041447	1	2.85±0.2 .112	5.6±0.2 .220	5.0 - 0.6 .185	1.35±0.5 .053	2.54±0.1 .100	.30	12	8	2400
2752045447	1	2.85±0.2 .112	5.6±0.2 .220	8.9 - 0.8 .335	1.35±0.5 .053	2.54±0.1 .100	.53	16	8	2400
2752051447	2	4.5 Max. .177 Max.	6.65 Max. .262 Max.	12.0 Max. .472 Max.	2.5±0.5 .098	3.00±0.1 .118	1.0	24	12	1000
2752065447	2	5.3 Max. .209 Max.	7.00 Max. .275 Max.	14.8 Max. .582 Max.	2.5±0.5 .098	3.00±0.1 .118	1.8	24	12	1000

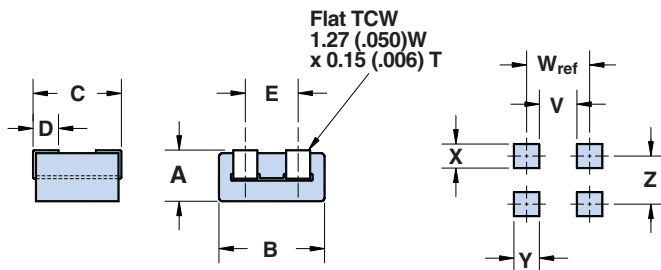

Figure 1
Common-Mode Bead

Land Pattern
for Fig. 1
E = Z

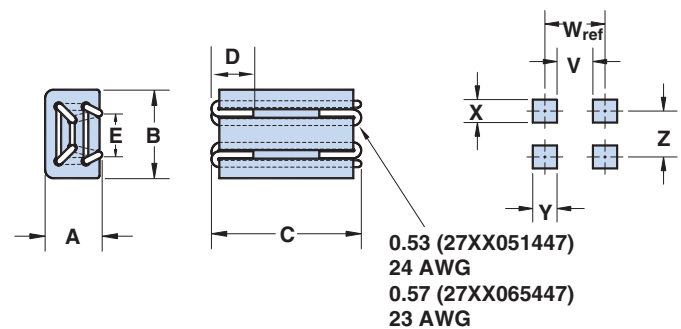

Figure 2
Common-Mode Bead

Land Pattern
for Fig. 2
E = Z

SM Beads (Common-Mode)

Broadband Frequencies 10-300 MHz (44 material)

Part Number	Typical Impedance(Ω)				Max Rdc(m Ω)	Land Pattern Dimensions				
	10 MHz	25 MHz ⁺	100 MHz ⁺	250 MHz		V	W (ref.)	X	Y	Z
2744041447	12	20	33	41	1.1	1.0 .040	4.0 .157	1.8 .071	3.0 .118	2.54 .100
2744045447	23	38	60	78	1.4	4.0 .158	7.0 .276	1.8 .071	3.0 .118	2.54 .100
2744051447	60	100	230	275 @300MHz	4.0	4.0 .158	9.0 .354	1.0 .040	5.0 .197	3.0 .118
2744065447	95	145	255	375 @300MHz	4.1	6.8 .268	11.8 .465	1.1 .043	5.0 .197	3.0 .118

Higher Frequencies 250-1000 MHz (52 material)

Part Number	Typical Impedance(Ω)				Max Rdc(m Ω)	Land Pattern Dimensions				
	100 MHz	250 MHz ⁺	500 MHz ⁺	1000 MHz		V	W (ref.)	X	Y	Z
2752041447	32	50	63	70	1.1	1.0 .040	4.0 .157	1.8 .071	3.0 .118	2.54 .100
2752045447	58	90	115	130	1.4	4.0 .158	7.0 .276	1.8 .071	3.0 .118	2.54 .100
2752051447	200	330	400	350	4.0	4.0 .158	9.0 .354	1.0 .040	5.0 .197	3.0 .118
2752065447	230	390	460	380	4.1	6.8 .268	11.8 .465	1.1 .043	5.0 .197	3.0 .118

⁺ Test frequency

Данный компонент на территории Российской Федерации

Вы можете приобрести в компании MosChip.

Для оперативного оформления запроса Вам необходимо перейти по данной ссылке:

<http://moschip.ru/get-element>

Вы можете разместить у нас заказ для любого Вашего проекта, будь то серийное производство или разработка единичного прибора.

В нашем ассортименте представлены ведущие мировые производители активных и пассивных электронных компонентов.

Нашей специализацией является поставка электронной компонентной базы двойного назначения, продукции таких производителей как XILINX, Intel (ex.ALTERA), Vicor, Microchip, Texas Instruments, Analog Devices, Mini-Circuits, Amphenol, Glenair.

Сотрудничество с глобальными дистрибьюторами электронных компонентов, предоставляет возможность заказывать и получать с международных складов практически любой перечень компонентов в оптимальные для Вас сроки.

На всех этапах разработки и производства наши партнеры могут получить квалифицированную поддержку опытных инженеров.

Система менеджмента качества компании отвечает требованиям в соответствии с ГОСТ Р ИСО 9001, ГОСТ РВ 0015-002 и ЭС РД 009

Офис по работе с юридическими лицами:

105318, г.Москва, ул.Щербаковская д.3, офис 1107, 1118, ДЦ «Щербаковский»

Телефон: +7 495 668-12-70 (многоканальный)

Факс: +7 495 668-12-70 (доб.304)

E-mail: info@moschip.ru

Skype отдела продаж:

moschip.ru

moschip.ru_4

moschip.ru_6

moschip.ru_9