

| REVISIONS | | | |
|-----------|----------------------------------|---------|----------|
| LTR | DESCRIPTION | DATE | APPROVED |
| N/C | INITIAL RELEASE PER ECN# T-20188 | 6/15/95 | M.HIGGY |
| A | RELEASED PER ECN# T-21271 | 3/10/97 | M.HIGGY |

CONTACT, ELECTRICAL CONNECTOR, CONCENTRIC TWINAX, SOCKET, SHIELDED, SIZE 8,
SOLDERTACT[®], (FOR MIL-C-38999 SERIES I, III AND IV)

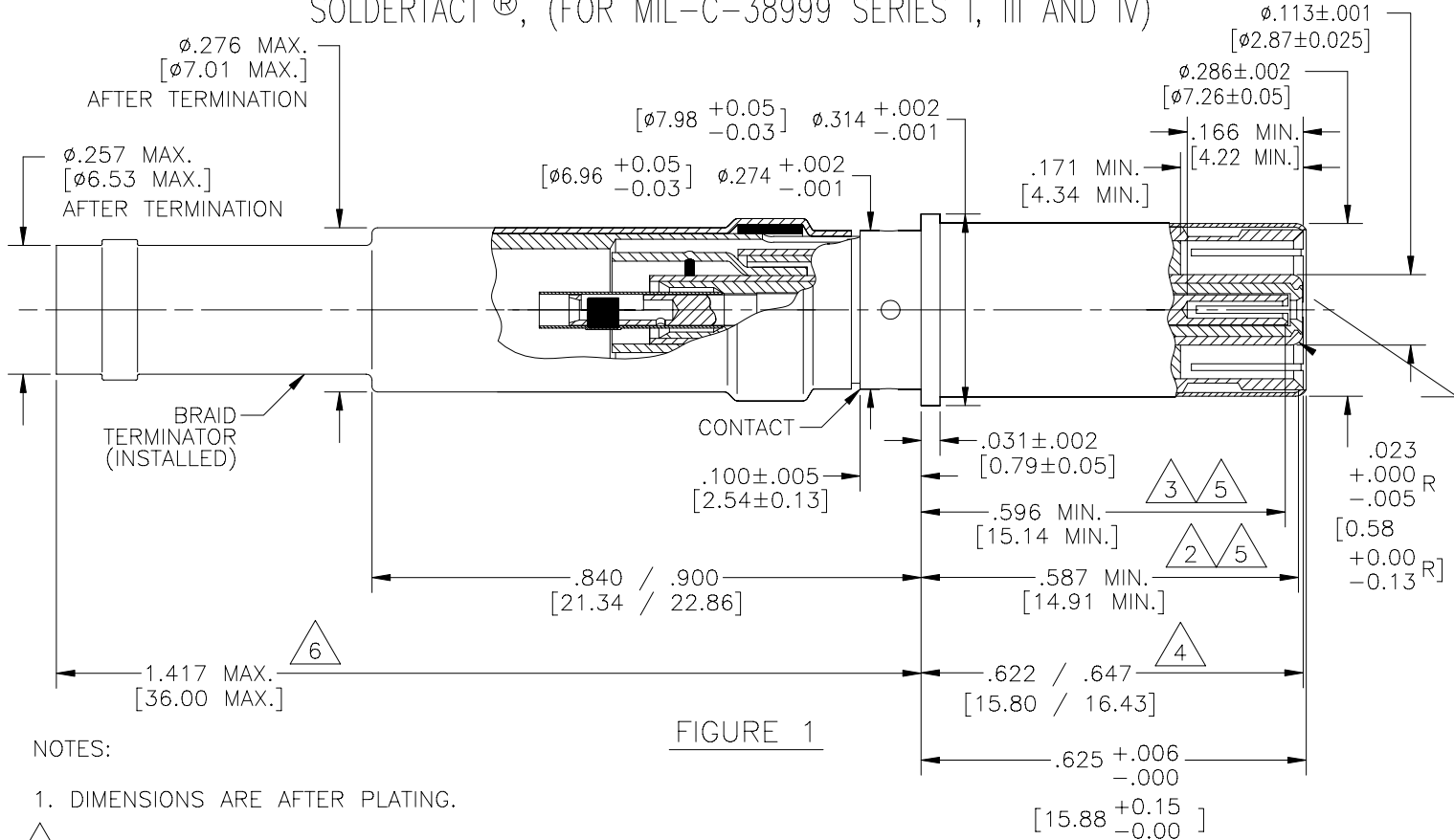

FIGURE 1

NOTES:

- DIMENSIONS ARE AFTER PLATING.
- SOCKET MATES WITH A $.218 \pm .001$ [5.54 ± 0.025] DIAMETER OUTER PIN.
- SOCKET MATES WITH A $.0240 \pm .0005$ [0.61 ± 0.013] DIAMETER CENTER PIN.
- TO END OF INTERMEDIATE PIN CONTACT.
- POINT AT WHICH A SQUARE ENDED PIN OF THE SAME BASIC DIAMETER AS THE MATING CONTACT FIRST ENGAGES THE OUTER/CENTER CONTACTS SPRING. PROVISION FOR CLEARANCE HOLE SHALL BE PROVIDED FOR THE TEST PIN.
- THIS DIMENSION APPLIES ONLY TO DK-602-0157-N-4 AND -8.

SPECIFICATION CONTROL DRAWING

If this document is printed it becomes uncontrolled.
Check for the latest revision.

| | | | | | | | |
|---|------------------------|-------------|------------|--|-----------------------------------|---|--------------|
| UNLESS OTHERWISE SPECIFIED DIMENSIONS ARE IN INCHES. METRIC DIMENSIONS ARE IN BRACKETS. | DRAWN | JOHN B. KAY | 95 MAY 2 | tyco Electronics | Raychem Products | Tyco Electronics Corporation 305 Constitution Drive Menlo Park, CA 94025 U.S.A. | |
| | CHECKED | JOHN B. KAY | 95 JUNE 15 | | | | |
| | APPROVED | M.HIGGY | 95 JUNE 15 | TITLE SOCKET, SOLDERTACT [®] , SIZE 8 MIL-C-39029/91 | | | |
| | APPROVED | | | SIZE | CODE IDENT. NO. | DWG. NO. | REV |
| DECIMALS .XXX ± _____ .XX ± _____ ANGLES _____ | CAD NAME T21271.DWG | | | A | 06090 | DK-602-0157-N-X | A |
| WEIGHT SEE TABLE 1 (SHEET 2) | THIRD ANGLE PROJECTION | | | DO NOT SCALE THIS DRAWING | | | SHEET 1 OF 5 |

If this document is printed it becomes uncontrolled. Check for the latest revision.

SEE SHEET 1 FOR REVISION

CONFIGURATION:

DK-602-0157-N-X IS A KIT, PER FIGURE 1, WHICH MAY CONTAIN A D-602-0157-N CONTACT, BRAID TERMINATOR AND ALIGNMENT/SEALING GROMMET (IS NOT SHOW) AS DESCRIBED IN TABLE I. NOTE: THE SUFFIX OF THE KIT PART NUMBER FOR THE PROPER MATCH OF THE CABLE SIZE, BRAID TERMINATOR AND GROMMET TYPE.

| TABLE I | | | | |
|-----------------|------------------|-----------------|------------|------------------------|
| KIT PART NUMBER | BRAID TERMINATOR | GROMMET | CABLE O.D. | KIT WEIGHT, GRAMS MAX. |
| DK-602-0157-N-0 | - | ① | .180 MAX. | - |
| DK-602-0157-N-1 | D-600-0044-1 | ① | .140 MAX. | 6.84 |
| DK-602-0157-N-2 | D-600-0044-2 | ① | .155 MAX. | 6.83 |
| DK-602-0157-N-3 | D-600-0044-3 | ① | .170 MAX. | 6.75 |
| DK-602-0157-N-4 | D-600-0044-4 | ① | .180 MAX. | 7.51 |
| DK-602-0157-N-5 | D-600-0044-1 | D-600-0071 | .140 MAX. | - |
| DK-602-0157-N-6 | D-600-0044-2 | D-600-0071 | .155 MAX. | - |
| DK-602-0157-N-7 | D-600-0044-3 | D-600-0071 | .170 MAX. | - |
| DK-602-0157-N-8 | D-600-0044-4 | D-600-0071 | .180 MAX. | - |
| DK-602-0157-N-9 | - | D-600-0125 ② | .180 MAX. | - |

- ① INTENDED TO BE USED WITH COSTUMER SUPPLIED GROMMET. PERFORMANCE IS RESPONSIBILITY OF THE COSTUMER.
- ② D-600-0125 SHORT GROMMET IS INTENDED FOR USE ONLY WITHOUT BRAID TERMINATOR.

QUALIFICATION: THIS CONTACT MEETS THE REQUIREMENTS OF U.S. AIR FORCE DRAWING 8912019.

REQUIREMENTS: DIMENSIONS (FIGURE 1), DESIGN CHARACTERISTICS, AND CONFIGURATIONS MEET THE REQUIREMENTS OF M39029/91, EXCEPT THAT THE TEMPERATURE RATING IS 125°C INSTEAD OF 175°C. TERMINATION IS BY SOLDERING INSTEAD OF CRIMPING. SEE TABLE II FOR CABLE ACCOMMODATIONS. THIS DESIGN, WHICH PROVIDES THE INDUSTRY STANDARD MATING SEQUENCE (SHIELD, INTERMEDIATE, CENTER CONTACT), IS AN IMPROVED VERSION OF THE EXISTING RAYCHEM SOLDERTACT® P/N DK-602-0157 SERIES. THIS SEQUENCE IS NOT GUARANTEED BY THE M39029/91 INTERFACE DIMENSIONS.

| TABLE II | | | | |
|---------------------|--|---|---------------------------------|--------------|
| CONTACT CAVITY SIZE | KIT PART NUMBER | CABLES ACCOMMODATED ③ | TYPE | CLASS |
| 8 | DK-602-0157-N-1 DK-602-0157-N-2 DK-602-0157-N-3 DK-602-0157-N-4 | RAYCHEM 10612 RAYCHEM 10613 RAYCHEM 10614 | (D) COPPER ALLOY SHIELDED | (A) 125°C |

③ OTHER APPLICATIONS SHOULD BE SUBMITTED TO TYCO ELECTRONICS/RAYCHEM FOR EVALUATION.

MATING CONTACT: D-602-0156-N-X AND M39029/90.

| | | | | | | | |
|--------------|--------|---------|----------|---------------------------|-----------------|-----------------------|-------------|
| SHEET 2 OF 5 | DRAWN | J.B.KAY | 95 MAY 2 | SIZE | CODE IDENT. NO. | DWG. NO. | REV |
| | ISSUED | | | A | 06090 | DK-602-0157-N-X | A |
| | | | | DO NOT SCALE THIS DRAWING | | CAD NAME T21271-2.DWG | SCALE: NONE |

SEE SHEET 1 FOR REVISION

TOOLS: SEE TABLE III.

| TABLE III | | | | |
|--------------------------------------|----------------------|-------------------------|------------------|---------------|
| HEATING TOOLS ④ | REFLECTORS ④ | HOLDING FIXTURES ④ | INSTALLING TOOLS | REMOVAL TOOLS |
| AA-400 SUPER HEATER | MINI SOLDER SLEEVE | RAYCHEM | M81969/14-06 | M81969/14-06 |
| STEINEL HOT AIR GUN HL-1802E-KIT-120 | STEINEL NOZZEL 07460 | AD-1319 WITH AT-1319-14 | M81969/46-06 | M81969/46-12 |

④ SEE TERMINATION PROCEDURE: TYCO ELECTRONICS/RAYCHEM ES 61231

ELECTRICAL PERFORMANCE:

If this document is printed it becomes uncontrolled. Check for the latest revision.

CONTACT RESISTANCE: SEE TABLE IV

| TABLE IV | | | | | | | | | | | | |
|----------------|-----------------------------------|----------------------------|-----------------------|-----------------------|----------------------------|-----------------------|-----------------------|----------------------------|-----------------------|-----------------------|----------------------------|-----------------------|
| TEST CABLE | MAXIMUM VOLTAGE DROP (MILLIVOLTS) | | | | | | | | | TEST CURRENT (AMPS) | | |
| | 25° +3° -0° C | | | ⑤ 25° +3° -0° C | | | 125° +3° -0° C | | | | | |
| | CONTACT | | | | | | | | | | | |
| | I N N E R | M I D D L E | O U T E R | I N N E R | M I D D L E | O U T E R | I N N E R | M I D D L E | O U T E R | I N N E R | M I D D L E | O U T E R |
| <u>RAYCHEM</u> | | | | | | | | | | | | |
| 10612 | | | | | | | | | | | | |
| 10613 | | | | | | | | | | | | |
| 10614 | | | | | | | | | | | | |
| | 55 | 55 | 75 | 66 | 66 | 90 | 94 | 94 | 128 | 1.0 | 1.0 | 12.0 |

⑤ AFTER CONDITIONING.

LOW SIGNAL LEVEL CONTACT RESISTANCE: SEE TABLE V

| TABLE V. LOW SIGNAL LEVEL CONTACT RESISTANCE (INNER CONTACT ONLY) | | |
|---|---|--------------------|
| TEST CABLE | MAXIMUM CONTACT RESISTANCE (MILLIOHMS) | |
| | INITIAL | AFTER CONDITIONING |
| | <u>RAYCHEM</u> 10612 10613 10614 | 55 |

| | | | | | | | |
|--------------|--------|---------|----------|---------------------------|-----------------|-----------------|-------------|
| SHEET 3 OF 5 | DRAWN | J.B.KAY | 95 MAY 2 | SIZE | CODE IDENT. NO. | DWG. NO. | REV |
| | ISSUED | | | A | 06090 | DK-602-0157-N-X | A |
| | | | | DO NOT SCALE THIS DRAWING | | CAD NAME | SCALE: NONE |
| | | | | T21271-3.DWG | | | |

SEE SHEET 1 FOR REVISION

If this document is printed it becomes uncontrolled.
Check for the latest revision.

DIELECTRIC WITHSTANDING VOLTAGE: SEE TABLE VI

| TABLE VI. DIELECTRIC WITHSTANDING VOLTAGE | | |
|---|-----------|-----------------------|
| CONTACTS | ALTITUDE | TEST VOLTAGES, AC RMS |
| INNER TO MIDDLE | SEA LEVEL | 1000 |
| MIDDLE TO OUTER | SEA LEVEL | 500 |

OPERATING FREQUENCY: 0 TO 20 MHZ (OPERATING FREQUENCY RANGE)

VOLTAGE RATING: 500 VOLTS RMS MAXIMUM AT SEA LEVEL; 125 VOLTS AT 70,000 FEET

MECHANICAL PERFORMANCE:

CONTACT ENGAGEMENT AND SEPARATION FORCE (SOCKET CONTACTS ONLY): SEE TABLE VII

| TABLE VII. CONTACT ENGAGEMENT AND SEPARATION FORCE | | | | |
|--|-----------------------------------|--------------------|-----------------------------------|--------------------|
| TEST PIN DIAMETER (INCH) | MINIMUM SEPARATION FORCE (OUNCES) | | MAXIMUM ENGAGEMENT FORCE (OUNCES) | |
| | INITIAL | AFTER CONDITIONING | INITIAL | AFTER CONDITIONING |
| .2190 ^{+.0000} / _{-.0001} | NA | NA | 48 | 60 |
| .2170 ^{+.0001} / _{-.0000} | 3.0 | 2.0 | NA | NA |
| .0245 ^{+.0000} / _{-.0001} | NA | NA | 12 | 14 |
| .0235 ^{+.0001} / _{-.0000} | 0.5 | 0.4 | NA | NA |

| | | | | | | | |
|--------------|--------|---------|----------|---------------------------|-----------------|-----------------|-------------|
| SHEET 4 OF 5 | DRAWN | J.B.KAY | 95 MAY 2 | SIZE | CODE IDENT. NO. | DWG. NO. | REV |
| | ISSUED | | | A | 06090 | DK-602-0157-N-X | A |
| | | | | DO NOT SCALE THIS DRAWING | | CAD NAME | SCALE: NONE |
| | | | | T21271-4.DWG | | | |

SEE SHEET 1 FOR REVISION

TENSILE STRENGTH: SEE TABLE VIII

| TABLE VIII. TENSILE STRENGTH (AT AMBIENT) | | | |
|---|---------------------------------------|----------------|---------------|
| TEST CABLE | TENSILE STRENGTH (POUNDS) (MINIMUM) ⑥ | | |
| | INNER CONTACT | MIDDLE CONTACT | OUTER CONTACT |
| <u>RAYCHEM</u> | | | |
| 10612 | 8 | 8 | 15 |
| 10613 | 8 | 8 | 25 |
| 10614 | 8 | 8 | 25 |

⑥ CABLE MAY BREAK BEFORE THE SOLDER JOINT TERMINATION.

VIBRATION: PER MIL-C-39029/91

HIGH IMPACT SHOCK: PER MIL-C-39029/91

ENVIRONMENTAL PERFORMANCE:

OPERATING TEMPERATURE: -65°C TO +125°C

HUMIDITY: PER MIL-C-39029/91

MATERIAL:

CONTACT BERYLLIUM COPPER, ALLOY 173, CONDITION H, ASTM B196, PER MIL-C-39029, TYPE D

PLATING OF CONTACT GOLD PLATE PER MIL-G-45204 TYPE II, GRADE C
50 MICROINCHES MINIMUM
OVER
NICKEL PER QQ-N-290A
50 MICROINCHES MINIMUM
OVER
COPPER STRIKE - 40 MICROINCHES MINIMUM

SOLDER Sn63 PER QQ-S-571

FLUX TYPE RMA PER MIL-F-14256

SHRINK TUBING HEAT-SHRINKABLE, RADIATION-CROSSLINKED
POLYVINYLIDENE FLUORIDE

DIELECTRIC ETFE FLUOROPOLYMER PER ASTM D3159

**If this document is printed it becomes uncontrolled.
Check for the latest revision.**

| | | | | | | | |
|--------------|--------|---------|----------|---------------------------|-----------------|-----------------------|-------------|
| SHEET 5 OF 5 | DRAWN | J.B.KAY | 95 MAY 5 | SIZE | CODE IDENT. NO. | DWG. NO. | REV |
| | ISSUED | | | A | 06090 | DK-602-0157-N-X | A |
| | | | | DO NOT SCALE THIS DRAWING | | CAD NAME T21271-5.DWG | SCALE: NONE |

Данный компонент на территории Российской Федерации

Вы можете приобрести в компании MosChip.

Для оперативного оформления запроса Вам необходимо перейти по данной ссылке:

<http://moschip.ru/get-element>

Вы можете разместить у нас заказ для любого Вашего проекта, будь то серийное производство или разработка единичного прибора.

В нашем ассортименте представлены ведущие мировые производители активных и пассивных электронных компонентов.

Нашей специализацией является поставка электронной компонентной базы двойного назначения, продукции таких производителей как XILINX, Intel (ex.ALTERA), Vicor, Microchip, Texas Instruments, Analog Devices, Mini-Circuits, Amphenol, Glenair.

Сотрудничество с глобальными дистрибьюторами электронных компонентов, предоставляет возможность заказывать и получать с международных складов практически любой перечень компонентов в оптимальные для Вас сроки.

На всех этапах разработки и производства наши партнеры могут получить квалифицированную поддержку опытных инженеров.

Система менеджмента качества компании отвечает требованиям в соответствии с ГОСТ Р ИСО 9001, ГОСТ РВ 0015-002 и ЭС РД 009

Офис по работе с юридическими лицами:

105318, г.Москва, ул.Щербаковская д.3, офис 1107, 1118, ДЦ «Щербаковский»

Телефон: +7 495 668-12-70 (многоканальный)

Факс: +7 495 668-12-70 (доб.304)

E-mail: info@moschip.ru

Skype отдела продаж:

moschip.ru

moschip.ru_4

moschip.ru_6

moschip.ru_9