

Wireless Charging Coil Assembly

AWCCA-107T52



RoHS / RoHS II Compliant



107 x 52mm

Moisture Sensitivity Level (MSL) – MSL = 1

FEATURES:

- Wireless Charging Transmitter Coil Array
- Outline Dimensions: 107.95mm x 52.5mm x 4mm
- Linear Array of Primary Coils, 2 lower coils (12.0 μ H), 1 upper coil (11.5 μ H).
- For Tx applications working with 12V
- High permeability shielding to protect sensitive electronics
- Durable construction
- RoHS / RoHS II Compliant & Pb free

APPLICATIONS:

- Wireless Charging Stations
- Automotive Industry (in car charging)
- Batteries Chargers
- Consumer Electronics Chargers
- Mobile Phone Charging Accessories
- Power Tool Charging Systems
- Approved part for IDT Part Number IDTP9036A

STANDARD SPECIFICATIONS

Maximum Ratings

Item	Value
Operating Temperature Range	-25°C to + 85°C RH \leq 90%.
Storage Temperature Range	-25°C to +85°C, 70% RH (Max.)

Part Number	Inductance		Q-Factor	Current Rating (rms)	Saturated Current (rms)	DC Resistance	R25	SRF
AWCCA-107T52H40-C01-B	Upper Coil 11.5 μ H \pm 10%	Lower Coil 12.0 μ H \pm 10%	80 \pm 30%	7.5A Typ.	18A	56m Ω \pm 20%	10K Ω \pm 3%	7MHz
Test Condition	100KHz / 1V		100KHz/1V	Δ T = 40 K	100KHz /1V	20 \pm 15°C	Ta=25 \pm 0.05°C P τ \leq 0.1mw	
Test Environment	Ambient Temperature: 20 \pm 15°C,RH:65% \pm 20%							

Test Conditions

A) - Ambient Temperature: 20 \pm 15°C, RH: 65% \pm 20%.

If any doubt on the results, measurements/tests should be made within the following limits: Ambient Temperature: 20 \pm 2°C, RH: 65% \pm 5%

B) - Isat: DC current at which the inductance drops approximate 5% from its value without current.

PART IDENTIFICATION:

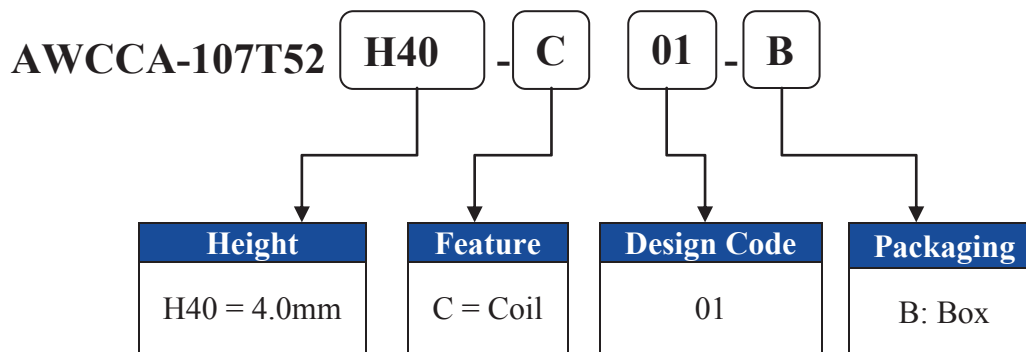

Wireless Charging Coil Assembly

AWCCA-107T52



RoHS / RoHS II Compliant



107 x 52mm

OUTLINE DIMENSIONS:

Out Line Dimensions (unit mm)

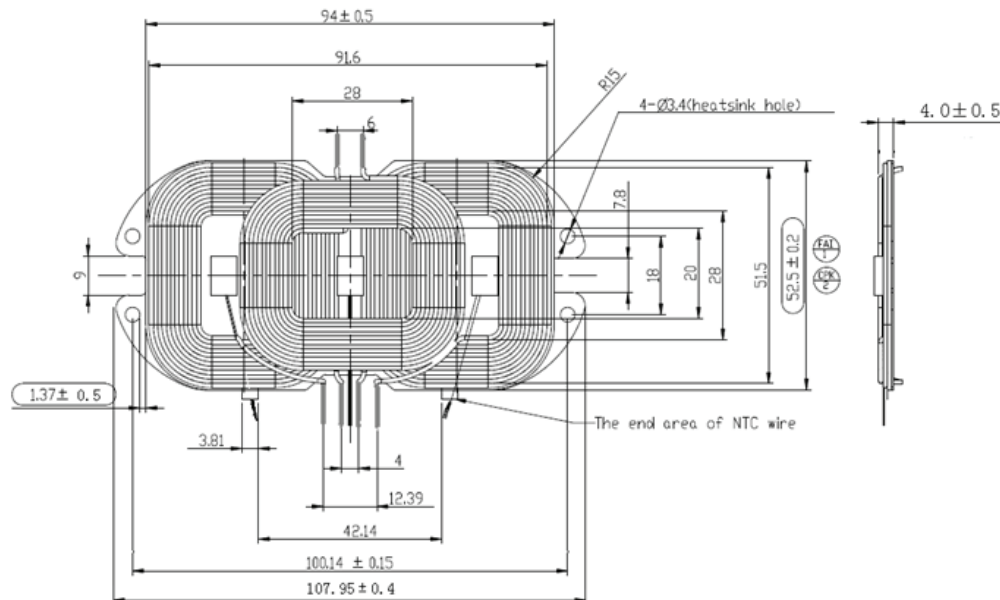

Winding Specifications

Number of Coils	Wire	Number of Turns	Inductance
Upper 1	φ 0.08×100	12	11.5μH ±10%
Lower 2	φ 0.08×100	12	12.0μH ±10%

Product Customization

Products can be customized according to the Wireless Charging Coil Standards or to customer requirements. Please refer to the following table for the feature ranges, and contact ABRACON or authorized distributor / agent for further details.

Inductance Range [μH]	DC Resistance Range [mΩ]	Dimension Range [mm]	Thickness range [mm]
1 ~ 100	10 ~ 1000	10 ~ 200	0.4 ~ 10

Manual Soldering: 350°C Max, 3secs

Storage condition

- Recommended storage conditions: -25°C~85°C, 70%RH (Max.)
- Service life: Within the limits of six month from being produced.
- The appearance and solder ability should be check, if product is not in expiry date.

Operation Conditions

- Use condition limit: T=-25°C ~ 85°C, RH≤ 90%.

ATTENTION: Abracon Corporation's products are COTS – Commercial-Off-The-Shelf products; suitable for Commercial, Industrial and, where designated, Automotive Applications. Abracon's products are not specifically designed for Military, Aviation, Aerospace, Life-dependant Medical applications or any application requiring high reliability where component failure could result in loss of life and/or property. For applications requiring high reliability and/or presenting an extreme operating environment, written consent and authorization from Abracon Corporation is required. Please contact Abracon Corporation for more information.

ABRACON IS
ISO9001:2008
CERTIFIED



ABRACON
CORPORATION

Visit www.abracon.com for Terms & Conditions of Sale **Revised: 12.08.13**

30332 Esperanza, Rancho Santa Margarita, California 92688

tel 949-546-8000 | fax 949-546-8001 | www.abracon.com

Данный компонент на территории Российской Федерации

Вы можете приобрести в компании MosChip.

Для оперативного оформления запроса Вам необходимо перейти по данной ссылке:

<http://moschip.ru/get-element>

Вы можете разместить у нас заказ для любого Вашего проекта, будь то серийное производство или разработка единичного прибора.

В нашем ассортименте представлены ведущие мировые производители активных и пассивных электронных компонентов.

Нашей специализацией является поставка электронной компонентной базы двойного назначения, продукции таких производителей как XILINX, Intel (ex.ALTERA), Vicor, Microchip, Texas Instruments, Analog Devices, Mini-Circuits, Amphenol, Glenair.

Сотрудничество с глобальными дистрибьюторами электронных компонентов, предоставляет возможность заказывать и получать с международных складов практически любой перечень компонентов в оптимальные для Вас сроки.

На всех этапах разработки и производства наши партнеры могут получить квалифицированную поддержку опытных инженеров.

Система менеджмента качества компании отвечает требованиям в соответствии с ГОСТ Р ИСО 9001, ГОСТ РВ 0015-002 и ЭС РД 009

Офис по работе с юридическими лицами:

105318, г.Москва, ул.Щербаковская д.3, офис 1107, 1118, ДЦ «Щербаковский»

Телефон: +7 495 668-12-70 (многоканальный)

Факс: +7 495 668-12-70 (доб.304)

E-mail: info@moschip.ru

Skype отдела продаж:

moschip.ru

moschip.ru_4

moschip.ru_6

moschip.ru_9