

Switch Mode Power Supply S8VK-S Series

480 W

**A Perfect Fit for Small Control Panels
Coated PCBs for Better Resistance
to Environment
Connections for Easy Wiring**



- Operation possible at ambient temperatures from -40 to 70°C.
- Side-by-side mounting possible (up to 55°C).
- Power Boost function at 150%.



Our shared Value Design for Panel (herein after referred to as Value Design) concept for the specifications of products used in control panels will create new value to our customer's control panels. Combining multiple products that share the Value Design concept will further increase the value provided to control panels.



Specifications

Ratings, Characteristics, and Functions

Item	Power rating		480 W	
	Output voltage		24 V	
Efficiency	115 VAC input *1		91% typ.	
	230 VAC input *1		93% typ.	
Input	Voltage range *2		Single-phase, 85 to 264 VAC, 90 to 350 VDC, 265 to 300 VAC (1 second)	
	Frequency *2		50/60 Hz (47 to 63 Hz)	
	Input current	115 VAC input *1		4.6 A typ.
		230 VAC input *1		2.3 A typ.
	Power factor			0.9 min.
	Leakage current *3	115 VAC input		0.5 mA max.
230 VAC input			1 mA max.	
Inrush current (for a cold start at 25°C)	115 VAC input		16 A typ.	
	230 VAC input		32 A typ.	
Output	Rated output current		20 A	
	Rated output electric power		480 W	
	Maximum boost current		30 A	
	Voltage adjustment range *4		21.6 to 28 V (with V.ADJ)	
	Start up time	115 VAC input *1		1000 ms max.
		230 VAC input *1		1000 ms max.
Hold time *5	115 VAC input *1		30 ms typ.	
	230 VAC input *1		30 ms typ.	
Additional functions	Overload protection		Yes, automatic reset	
	Overvoltage protection		Yes, 130% or higher of rated output voltage, power shut off (shut off the input voltage and turn on the input again)	
	Output indicator		Yes (LED: Green)	
	Low-voltage detection output		Yes (Photoswitch output: 30 VDC max., 50 mA max.)	
Insulation	Withstand voltage		3.0 kVAC for 1 min. (between all input terminals and output terminals), current cutoff 20 mA	
			2.0 kVAC for 1 min. (between all input terminals and PE terminals), current cutoff 20 mA	
			1.0 kVAC for 1 min. (between all output terminals and PE terminals), current cutoff 20 mA	
Insulation resistance			500 VAC for 1 min (between all output terminals and all low-voltage detection output terminals), current cutoff 10 mA	
Environment	Vibration resistance		100 MΩ min. (between all output terminals/all low-voltage detection output terminals and all input terminals/PE terminals) at 500 VDC	
	Shock resistance		10 to 55 Hz, maximum 5G, 0.42 mm half amplitude for 2 h each in X, Y, and Z directions	
Construction	Weight		150 m/s ² , 3 times each in ±X, ±Y, ±Z directions	
			1150 g max.	

*1. The value is when both rated output voltage and rated output current are satisfied.

*2. Do not use an inverter output for the product. Inverters with an output frequency of 50/60 Hz are available, but the rise in the internal temperature of the product may result in ignition or burning.

If the input is connected to a UPS, do not connect a UPS with a square-wave output.

Doing so will cause the internal temperature of the product to increase, possibly causing smoking or burning.

*3. The value for the leakage current is determined according to the Electrical Appliances and Material Safety Act.

*4. If the output voltage adjuster (V. ADJ) is turned, the voltage will increase by more than 28 V min of the voltage adjustment range. When adjusting the output voltage, confirm the actual output voltage from the product and be sure that the load is not damaged.

*5. A characteristic when the ambient operating temperature of 25°C.

For details, refer to the website. (<http://www.ia.omron.com/>)

Engineering Data

480 W (S8VK-S48024) Horizontal separation: 15 mm or more

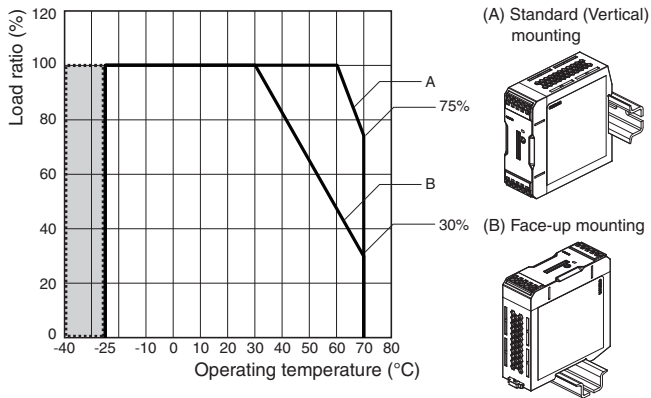

480 W (S8VK-S48024) Horizontal separation: Less than 15 mm

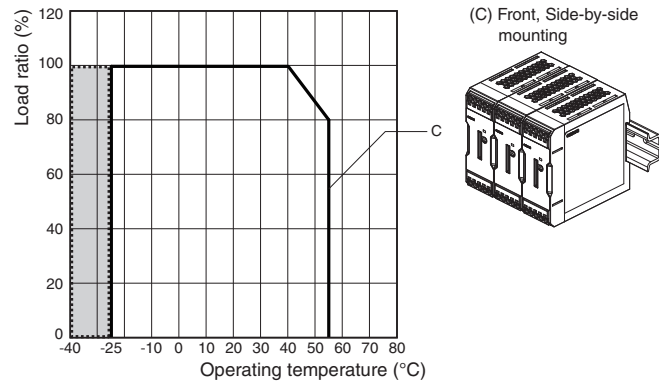

- Note: 1.** At less than 100 VAC, derate the load at 1%/V.
2. For a DC input, reduce the load given in the above derating curve by multiplying by the following coefficients.
 S8VK-S48024: 0.8
3. In the shaded area, time is required to reach the rated output voltage after the input voltage is applied.

- Note: 1.** Apply the rated voltage
2. In the shaded area, time is required to reach the rated output voltage after the input voltage is applied.

Construction and Nomenclature

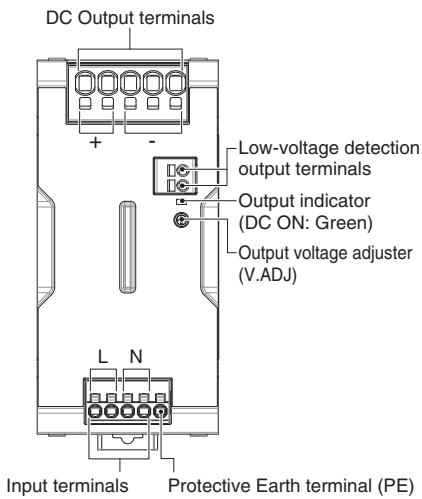

Dimensions

(Unit: mm)

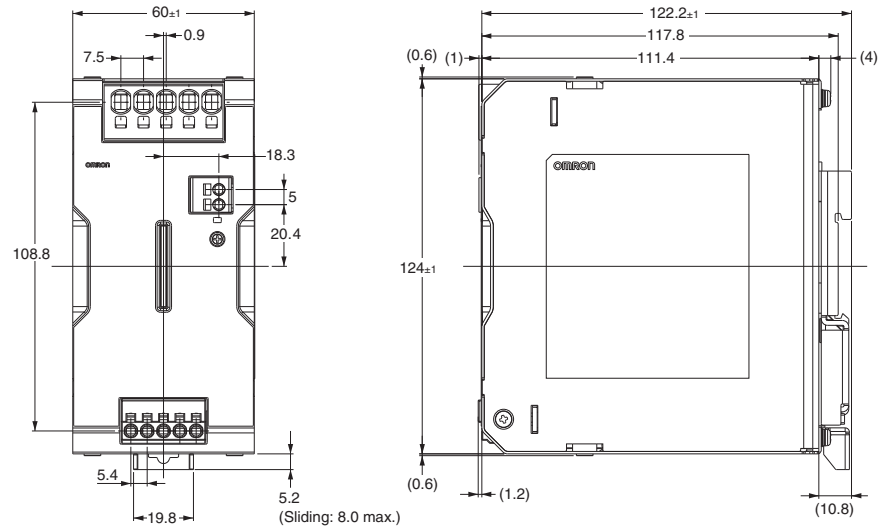

S8VK-S48024

Standards

Harmonic current emissions		Conforms to EN 61000-3-2
EMI	Conducted Emissions	Conforms to EN 61204-3 Class B, EN 55011 Class B
	Radiated Emissions	Conforms to EN 61204-3 Class B, EN 55011 Class B
EMS		Conforms to EN 61204-3 high severity levels
Approved Standards		UL Listing: UL 508 cUL: CSA C22.2 No107.1, CSA C22.2 No213 UL UR: UL 60950-1 (Recognition) OVCII (≤ 3000 m) Pol2 cUR: CSA C22.2 No.60950-1 OVCII (≤ 3000 m) Pol2 EN: EN 50178 OVCIII (≤ 2000 m) OVCII (2000 m≤ and≤3000) Pol2, EN 60950-1 OVCII (≤ 3000 m) Pol2
Conformed Standards		PELV (EN/IEC 60204-1) * EN/IEC 61558-2-16:2009+A1:2013 *
SEMI		Conforms to F47-0706 (200 to 240 VAC input)

* Refer to *Standard Compliance*, below.

Model Number Structure

S8VK- S

1 2

1. Power Ratings

030: 30 W
060: 60 W
120: 120 W
240: 240 W
480: 480 W

2. Output voltage

24: 24 V

Power ratings	Rated input voltage	Rated output voltage	Rated output current	Maximum boost current	Model number
30 W	100 to 240 VAC (allowable range: 85 to 264 VAC or 90 to 350 VDC)	24 V	1.3 A	1.56 A	S8VK-S03024
60 W		24 V	2.5 A	3 A	S8VK-S06024
120 W		24 V	5 A	6 A	S8VK-S12024
240 W		24 V	10 A	15 A	S8VK-S24024
480 W		24 V	20 A	30 A	S8VK-S48024

Safety Precautions

Be sure to read the precautions for all models in the website at: <http://www.ia.omron.com/>.

OMRON AUTOMATION AMERICAS HEADQUARTERS • Chicago, IL USA • 847.843.7900 • 800.556.6766 • www.omron247.com

OMRON CANADA, INC. • HEAD OFFICE

Toronto, ON, Canada • 416.286.6465 • 866.986.6766 • www.omron247.com

OMRON ELECTRONICS DE MEXICO • HEAD OFFICE

México DF • 52.55.59.01.43.00 • 01-800-226-6766 • mela@omron.com

OMRON ELECTRONICS DE MEXICO • SALES OFFICE

Apodaca, N.L. • 52.81.11.56.99.20 • 01-800-226-6766 • mela@omron.com

OMRON ELETRÔNICA DO BRASIL LTDA • HEAD OFFICE

São Paulo, SP, Brasil • 55.11.2101.6300 • www.omron.com.br

OMRON ARGENTINA • SALES OFFICE

Cono Sur • 54.11.4783.5300

OMRON CHILE • SALES OFFICE

Santiago • 56.9.9917.3920

OTHER OMRON LATIN AMERICA SALES

54.11.4783.5300

OMRON EUROPE B.V. • Wegalaan 67-69, NL-2132 JD, Hoofddorp, The Netherlands. • +31 (0) 23 568 13 00 • www.industrial.omron.eu

Authorized Distributor:

Controllers & I/O

- Machine Automation Controllers (MAC) • Motion Controllers
- Programmable Logic Controllers (PLC) • Temperature Controllers • Remote I/O

Robotics

- Industrial Robots • Mobile Robots

Operator Interfaces

- Human Machine Interface (HMI)

Motion & Drives

- Machine Automation Controllers (MAC) • Motion Controllers • Servo Systems
- Frequency Inverters

Vision, Measurement & Identification

- Vision Sensors & Systems • Measurement Sensors • Auto Identification Systems

Sensing

- Photoelectric Sensors • Fiber-Optic Sensors • Proximity Sensors
- Rotary Encoders • Ultrasonic Sensors

Safety

- Safety Light Curtains • Safety Laser Scanners • Programmable Safety Systems
- Safety Mats and Edges • Safety Door Switches • Emergency Stop Devices
- Safety Switches & Operator Controls • Safety Monitoring/Force-guided Relays

Control Components

- Power Supplies • Timers • Counters • Programmable Relays
- Digital Panel Meters • Monitoring Products

Switches & Relays

- Limit Switches • Pushbutton Switches • Electromechanical Relays
- Solid State Relays

Software

- Programming & Configuration • Runtime

Данный компонент на территории Российской Федерации

Вы можете приобрести в компании MosChip.

Для оперативного оформления запроса Вам необходимо перейти по данной ссылке:

<http://moschip.ru/get-element>

Вы можете разместить у нас заказ для любого Вашего проекта, будь то серийное производство или разработка единичного прибора.

В нашем ассортименте представлены ведущие мировые производители активных и пассивных электронных компонентов.

Нашей специализацией является поставка электронной компонентной базы двойного назначения, продукции таких производителей как XILINX, Intel (ex.ALTERA), Vicor, Microchip, Texas Instruments, Analog Devices, Mini-Circuits, Amphenol, Glenair.

Сотрудничество с глобальными дистрибьюторами электронных компонентов, предоставляет возможность заказывать и получать с международных складов практически любой перечень компонентов в оптимальные для Вас сроки.

На всех этапах разработки и производства наши партнеры могут получить квалифицированную поддержку опытных инженеров.

Система менеджмента качества компании отвечает требованиям в соответствии с ГОСТ Р ИСО 9001, ГОСТ РВ 0015-002 и ЭС РД 009

Офис по работе с юридическими лицами:

105318, г.Москва, ул.Щербаковская д.3, офис 1107, 1118, ДЦ «Щербаковский»

Телефон: +7 495 668-12-70 (многоканальный)

Факс: +7 495 668-12-70 (доб.304)

E-mail: info@moschip.ru

Skype отдела продаж:

moschip.ru

moschip.ru_4

moschip.ru_6

moschip.ru_9