

**Description**

Developed in the late 1940's, the BNC is a miniature version of the Type C. BNC stands for Bayonet Neill Concelman and is available in 50 Ohm and 75 Ohm impedance versions.

The BNC product line is a miniature quick connect / disconnect RF connector. It features two bayonet lugs on the female connector; mating is achieved with only a quarter turn of the coupling nut.

Primary Applications - Ideally suited for cable termination for miniature to subminiature coaxial cable (RG-58, 59, to RG-179, RG-316, etc.)

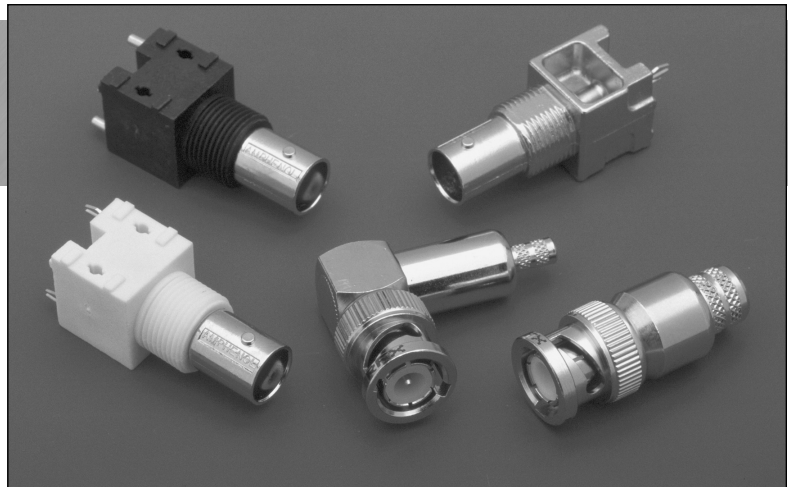

**Features/Benefits**

- Bayonet coupling mechanism provides quick mating and unmating.
- 50 and 75 ohm impedance designs allow customers to match impedance to system requirements.
- 50 and 75 ohm connectors are intermateable to ensure nondestructive mating.
- Three grades of connectors are available for military, industrial and commercial applications.

**Applications**

- Antennas
- Automotive (GPS)
- Base Stations
- Broadcast (75 ohm)
- Cable Assemblies
- Cable Modems
- Components
- Computers/LANs
- Instrumentation
- Network Analyzers
- Oscilloscopes
- Medical Equipment
- Mil-Aerospace
- Networks
- Radios
- Satcom
- Surge Protection
- Telecom

**50 ohm  
BNC Cable Connectors**

Specifications	107
Cable Plugs	108-109
Cable Jacks	110
Receptacles	114-115
PCB Receptacles	116-118
Adapters	119-121
Caps & Accessories	122

**75 ohm**

Specifications	124
High Performance Plugs	125-126
Jacks & Receptacles	127
PCB Receptacles	128-132
Adapters	133-134

## Description

Amphenol 50 ohm BNC connectors are miniature, lightweight units designed to operate up to 11 GHz and typically yield low reflection through 4 GHz. Designed to accommodate a large variety of RG and industry standard cables, BNC connectors are available in crimp-crimp, clamp-solder, SURETWIST®, and field serviceable termination styles. A full line of printed circuit board receptacles, bulkhead receptacles, resistor terminations, and other accessories complement the product offering.

## Features/Benefits

Amphenol manufactures a full line of BNC connectors to meet all users' needs. Parts which are listed with the appropriate M39012 number in the catalog are **Military Grade** connectors produced in accordance with and actively qualified to the military specification MIL-C-39012. Connectors not listed with the M39012 number constitute the **Industrial Grade** product offering. These connectors provide comparable performance and generally feature nickel plated brass bodies, Teflon insulators, and either gold or silver plated center contacts. Amphenol's **Commercial Grade** connector offering carries the part number designation "RFX" for easy recognition. These low cost connectors typically utilize diecast and molded components. While



performance will not be equal to the Industrial or Military grade products, these connectors are ideal for use on a variety of commercial applications.

Amphenol's 50 ohm BNC connectors (where indicated) are recognized under the Component Program of Underwriter's Laboratories, Inc. They are ideal for use with medical equipment and test instrumentation where safety cannot be compromised.

## Applications

- Computers/LANs
- Test and Measurement
- Medical Equipment
- Telecommunications
- Wireless/Networks

## 50 ohm

BNC 50 ohm Connectors	106
Plugs and Jacks	108-113
Adapters	119
PCB Connectors	120-121

## ELECTRICAL

Impedance	50 ohms nominal ■
Frequency range	0-4 GHz w/low reflection
Voltage rating	500 volts peak
Dielectric withstanding voltage	1,500 volts rms.
VSWR	M39012 straight connectors: 1.3 max. 0-4 GHz M39012 right angle: 1.35 max. 0-4 GHz
Other (MIL-C-39012 cable connectors)	Contact resistance: center contact 1.5 milliohm outer contact 0.2 milliohm Braid to body 0.1 milliohm RF leakage: - 55 dB minimum at 3 GHz Insertion loss: 0.2 dB maximum at 3 GHz Insulation resistance: 5000 megohms (min.)

## MECHANICAL

Mating	2-stud bayonet coupling per M39012
Cable affixment (braid or jacket)	All crimps: hex braid crimp. Clamps: screw-thread nut and braid clamp.
Cable affixment (center conductor)	Crimps: crimp or solder All others: solder only
Captivated contact	All crimps Others: where specified.
Cable retention	Crimps: 20-100 lbs. All others: 30-70 lbs.

## MATERIAL

Center contacts	Male: brass Female: Beryllium copper or phosphor bronze. Silver or gold plated
Other metal parts	Brass, Nickel finish except M39012 silver.
Insulators	TFE; copolymer of styrene, glass-TFE (hermetically sealed)
Clamp gaskets	Synthetic rubber, Silicone rubber
Crimp ferrule	Copper / Brass

## ENVIRONMENTAL

Temperature range	TFE insulators: - 65°C to + 165°C Copolymer of Styrene: - 55°C to + 85°C
Weatherproof	Clamps with clamp gaskets. Crimps with heat-shrink tubing.
Hermetic seals	Pass helium leak test of 2 X 10 <sup>-8</sup> cc/sec
Shock	MIL-Std. 202 method 202
Vibration	MIL-Std. 202 method 204 (test cond. D)
Moisture resistance	MIL-Std. 202 method 106
Corrosion	MIL-Std. 202 method 101 (test cond. B)
Temperature cycling	MIL-Std. 202 method 102 (test cond. D)
Altitude	MIL-Std. 202 method 105 (test cond. C)

## MILITARY SPECIFICATIONS

MIL-C-39012	Where applicable
-------------	------------------

NOTE: These characteristics are typical and may not apply to all connectors.

■ Also see 75 ohm BNC connectors in the following section

## PLUG

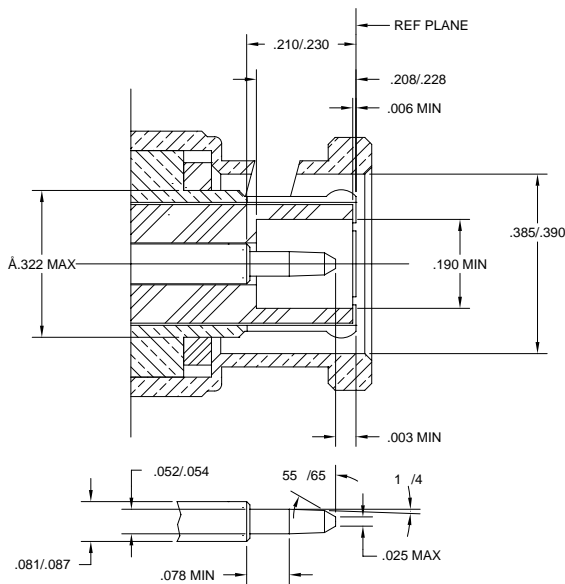

## JACK

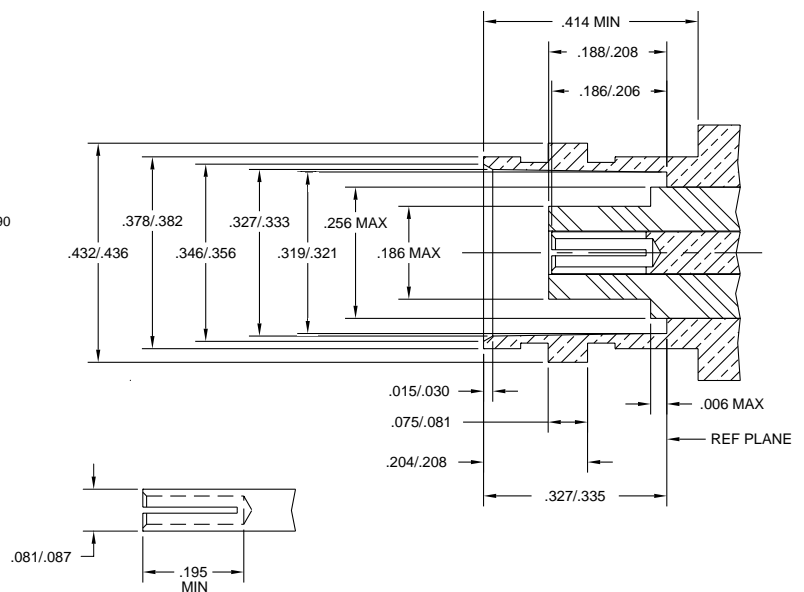

# BNC 50 ohm 3-Piece Cable Crimp Plugs

Fig. 1

BNC 3-Piece Crimp Plugs

36650-1003	68175-5RFX	31-320-1006	31-326	31-5557-RFX†
36650-3RFX	31-242	31-320-RFX	31-326-RFX	31-5558-RFX
36875	31-242-RFX	31-321	31-4320	31-5560-RFX†
68175-1003	31-315	31-321-1000	31-4321	31-5559-RFX
68175-1005	31-315-1005	31-321-RFX	31-4411	31-5559-1RFX
68175-1011	31-315-RFX	31-321-10RFX	31-4427	31-5556-1RFX
68175-11RFX	31-320	31-325	31-5556-RFX†	

Fig. 2

BNC Crimp Plugs

31-351
31-359
31-371

## BNC 3-PIECE CRIMP CABLE PLUGS

Cable RG-/U	Cable Attachment		Dimensions, inches (millimeters)			Notes			Military Number	Amphenol Number	Fig.
	Outer	Inner	a ■	b	c •	CAI	Plt.	Ins.			
6 TYPE (.314 OD)	Crimp	Crimp	1.17(29.7)	.571(14.5)	.314(8.0)	C26	P7	D23	—	31-5558-RFX	1
55, 142, 223, 400	Crimp	Crimp	1.27(32.1)	.563(14.3)	.220(5.59)	C26	P15	D1	—	36875*	1
	Crimp	Crimp	1.20(30.5)	.563(14.3)	.220(5.59)	C26	P15	D1	M23329/3-02,3-04	31-326*	1
	Crimp	Crimp	1.11(28.2)	.563(14.3)	.220(5.59)	C26	P7	D26	—	31-326-RFX	1
	Crimp	Press Fit	1.31(33.3)	.571(14.5)	.212(5.4)	C7R	P7	D23	—	31-5557-RFX†	1
58, 141	Crimp	Crimp	1.11(28.2)	.563(14.3)	.206(5.2)	C26	P15	D1	M23329/3-01,3-03	31-5800	☆
	Crimp	Crimp	1.17(29.8)	.571(14.5)	.210(5.3)	C26	P7	D26	—	31-320*	1
	Crimp	Crimp	1.17(29.8)	.571(14.5)	.210(5.3)	C26	P7	D26	—	31-320-RFX	1
	Crimp	Solder	1.47(37.3)	.562(14.3)	.206(5.2)	C26b	P15	D1	—	31-351*	2
	Crimp	Crimp	1.09(27.8)	.563(14.3)	.206(5.23)	C26	P33	D1	M39012/16-0013	31-4320*	1
Plenum 58	Crimp	Crimp	1.28(32.6)	.571(14.5)	.181(4.6)	C26	P7	D26	—	36650-3RFX	1
59 (20 AWG Ctr. Contact)	Crimp	Press Fit	1.31(33.3)	.571(14.5)	.260(6.6)	C7R	P7	D23	—	31-5556-RFX†	1
59, 62, 140, 210, 302	Crimp	Crimp	1.11(28.2)	.563(14.3)	.260(6.6)	C26	P15	D26	—	31-5900	☆
	Crimp	Crimp	1.12(28.5)	.562(14.3)	.261(6.6)	C26	P15	D1	M23329/3-05	31-321*	1
59	Crimp	Crimp	1.17(29.8)	.571(14.5)	.260(6.6)	C26	P7	D26	—	31-321-RFX	1
	Crimp	Solder	1.47(37.3)	.563(14.3)	.261(6.6)	C26b	P15	D1	—	31-359*	2
	Crimp	Crimp	1.12(28.5)	.562(14.3)	.261(6.6)	C26	P33	D1	M39012/16-0015	31-4321	1
59 (20 AWG Ctr. Cond.)	Crimp	Crimp	1.11(28.2)	.562(14.3)	.261(6.6)	C26	P15	D1	—	68175-1005	1
	Crimp	Crimp	1.17(29.8)	.571(14.5)	.260(6.6)	C26	P7	D26	—	68175-5RFX	1
	Crimp	Crimp	1.11(28.2)	.563(14.3)	.220(5.6)	C26	P33	D1	M39012/16-0503	31-4427*	1
142, 400	Crimp	Crimp	1.28(32.6)	.571(14.5)	.212(5.4)	C26	P7	D26	—	68175-11RFX	1
Plenum 59, 62	Crimp	Crimp	1.28(32.6)	.571(14.5)	.212(5.4)	C26	P7	D26	—	31-5560-RFX†	1
	Crimp	Press Fit	1.31(33.3)	.571(14.5)	.212(5.4)	C7R	P7	D23	—	31-371*	2
174, 179, 187, 188, 316	Crimp	Solder	1.34(34.1)	.563(14.3)	.128(3.25)	C26b	P15	D9	—	31-315	☆
174, 188, 316	Crimp	Crimp	1.19(30.2)	.562(14.3)	.125(3.2)	C26	P15	D1	—	31-315	☆
	Crimp	Crimp	1.19(30.2)	.571(14.5)	.106(2.7)	C26	P7	D23	—	31-315-RFX	1
	Crimp	Crimp	1.19(30.2)	.562(14.3)	.117(3.0)	C26	P15	D1	—	31-242*	1
179, 187	Crimp	Crimp	1.19(30.2)	.571(14.5)	.106(2.7)	C26	P7	D23	—	31-242-RFX	1
	Crimp	Crimp	1.11(28.2)	.562(14.3)	.135(3.4)	C26	P16	D1	—	31-315-1005	1
Dbl. Br. RG-316	Crimp	Crimp	1.11(28.2)	.562(14.3)	.135(3.4)	C26	P16	D1	—	31-315-1005	1
Belden 8213	Crimp	Crimp	1.59(40.5)	.562(14.3)	.418(10.6)	C26	P17	D1	—	31-4411	1
Belden 8218	Crimp	Crimp	1.11(28.2)	.562(14.3)	.175(4.4)	C26	P15	D1	—	31-325*	1
Belden 8281, 88281	Crimp	Crimp	1.21(30.7)	.562(14.3)	.342(8.7)	C26	P15	D1	—	31-321-1000*	1
	Crimp	Crimp	1.17(29.8)	.571(14.5)	.334(8.5)	C26	P7	D26	—	31-321-10RFX	1
Belden 9259	Crimp	Crimp	1.11(28.2)	.562(14.3)	.261(6.6)	C26	P15	D1	—	68175-1003	1
Belden 9907, 89907	Crimp	Crimp	1.11(28.2)	.562(14.3)	.196(5.0)	C26	P15	D1	—	31-320-1006	1
Belden 1560A, 82259, 89259, Plenum 59, 62	Crimp	Crimp	1.11(28.2)	.563(14.3)	.220(5.6)	C26	P15	D1	—	68175-1011	1
Belden 82907, 88240, 89907, Plenum 58	Crimp	Crimp	1.11(28.2)	.563(14.3)	.175(4.4)	C26	P15	D1	—	36650-1003	1
Plenum 58	Crimp	Press Fit	1.28(32.6)	.571(14.5)	.181(4.6)	C26	P7	D26	—	36650-3RFX	1
Plenum 58	Crimp	Press Fit	1.03(25.0)	.563(14.3)	.213(4.6)	C26	P7	D28	—	31-5559-1RFX	1
Plenum 58	Crimp	Press Fit	1.03(25.0)	.563(14.3)	.26(4.6)	C7R	P7	D23	—	31-5556-1RFX	1

\* recognized under the component program of U.L., Inc. • accommodates cable diameter ☆ see Fig. 1 and table on page 109. ▲ distributor stocked  
 ■ includes outer ferrule † features preinstalled center contact

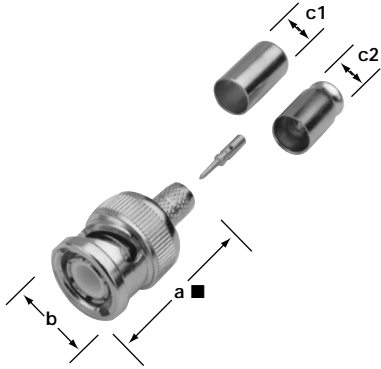
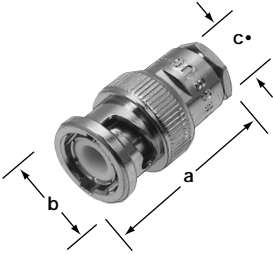

<p>Fig. 1</p>  <p style="text-align: center;">BNC Crimp Plugs for Networking</p> <p style="text-align: center;"><b>31-5800</b> <b>31-5900</b></p>	<p>Fig. 2</p>  <p style="text-align: center;">BNC Clamp Plugs</p> <table style="width: 100%; border: none;"> <tr> <td style="width: 33%;"><b>6775</b></td> <td style="width: 33%;"><b>31-2</b></td> <td style="width: 33%;"><b>31-3202</b></td> </tr> <tr> <td><b>9350</b></td> <td><b>31-2-RFX</b></td> <td><b>31-3301</b></td> </tr> <tr> <td><b>15875</b></td> <td><b>31-202</b></td> <td><b>31-3302</b></td> </tr> <tr> <td><b>16300</b></td> <td><b>31-212</b></td> <td></td> </tr> <tr> <td><b>69475</b></td> <td><b>31-212-1005</b></td> <td></td> </tr> <tr> <td><b>84975</b></td> <td><b>31-212-RFX</b></td> <td></td> </tr> </table>	<b>6775</b>	<b>31-2</b>	<b>31-3202</b>	<b>9350</b>	<b>31-2-RFX</b>	<b>31-3301</b>	<b>15875</b>	<b>31-202</b>	<b>31-3302</b>	<b>16300</b>	<b>31-212</b>		<b>69475</b>	<b>31-212-1005</b>		<b>84975</b>	<b>31-212-RFX</b>	
<b>6775</b>	<b>31-2</b>	<b>31-3202</b>																	
<b>9350</b>	<b>31-2-RFX</b>	<b>31-3301</b>																	
<b>15875</b>	<b>31-202</b>	<b>31-3302</b>																	
<b>16300</b>	<b>31-212</b>																		
<b>69475</b>	<b>31-212-1005</b>																		
<b>84975</b>	<b>31-212-RFX</b>																		

## BNC CRIMP-CRIMP CABLE PLUGS FOR NETWORKING

Cable RG-/U	Dimensions, inches (millimeters)				Notes			Amphenol Number	Fig.
	a ■	b	c • 1	c • 2	CAI	Plt.	Ins.		
58, 58A, 58B, 58C, 141, Plenum 58, Belden 9907, 89907, Comscope 2104K, 2135, 3104	1.11(28.2)	.563(14.3)	.209(5.3)	.181(4.60)	C26	P15	D26	<b>31-5800</b>	1 ▲
59 & 62, RG-59 20GACC, Plenum 59 & 62; Belden 1515A, 8212, 8221, 8241, 8241A, 8241F, 8263, 8279A, 9100, 9209, 9209A, 9240, 9244, 9259, 9274, 9275, 9659, 1426A, 82108, 88241, 82241, 89259, 82259, 1506A; AT&T 734A; Comscope 5553, 2020K, 3037V, 2249K	1.11(28.2)	.563(14.3)	.261(6.6)	.220(5.59)	C26	P15	D26	<b>31-5900</b>	

## BNC CLAMP CABLE PLUGS

Cable RG-/U	Cable Attachment		Dimensions, inches (millimeters)			Notes			Military Number	Amphenol Number	Fig.
	Outer	Inner	a ■	b	c •	CAI	Plt.	Ins.			
<b>6</b>	Clamp	Solder	1.25(31.8)	.563(14.3)	.348(8.8)	C25	P1	D6	—	<b>9350*</b>	▲
<b>8, 9, 11, 213, 214</b>	Clamp	Solder	1.66(42.1)	.688(17.5)	.437(11.1)	C25	P1	D1	UG-959/U	<b>6775*</b>	
<b>55, 58, 141, 142, 223, 400</b>	Clamp	Solder	1.06(27.0)	.562(14.3)	.224(5.7)	C25	P1	D1	UG-88C/U	<b>31-202*</b>	
	Clamp	Solder	1.06(27.0)	.563(14.3)	.221(5.6)	C25	P1	D1	UG88E/U	<b>31-3202*</b>	
<b>58, 141, 142, 400</b>	Clamp	Solder	.969(24.6)	.563(14.3)	.212(5.38)	C25	P1	D1	UG-88/U	<b>31-2*</b>	
	Clamp	Solder	1.07(27.2)	.571(14.5)	.212(5.38)	C25	P7	D23	—	<b>31-2-RFX</b>	
	Clamp	Solder	1.06(27.0)	.563(14.3)	.224(5.7)	C25	P33	D1	M39012/16-0101	<b>31-3301*</b>	
<b>59, 62, 71, 140, 210, 302</b>	Clamp	Solder	1.10(27.9)	.562(14.3)	.255(6.5)	C25	P1	D1	UG260B/U	<b>31-212*</b>	
	Clamp	Solder	1.07(27.2)	.571(14.5)	.256(6.5)	C25	P7	D23	—	<b>31-212-RFX</b>	
	Clamp	Solder	1.06(27.0)	.563(14.3)	.255(6.5)	C25	P33	D1	M39012/16-0102	<b>31-3302*</b>	
<b>59 (20GA CC)</b>	Clamp	Solder	1.06(27.0)	.563(14.3)	.255(6.48)	C25	P1	D1	—	<b>31-212-1005</b>	
<b>122</b>	Clamp	Solder	1.06(27.0)	.563(14.3)	.177(4.5)	C25	P1	D1	UG1033/U	<b>84975*</b>	
<b>174, 179, 187, 188, 316</b>	Clamp	Solder	1.06(27.0)	.563(14.3)	.116(2.9)	C25	P1	D1	—	<b>69475*</b>	
<b>178, 196</b>	Clamp	Solder	1.00(25.4)	.563(14.3)	.094(2.39)	C25	P1	D9	—	<b>15875*</b>	
<b>180</b>	Clamp	Solder	1.00(25.4)	.563(14.3)	.150(3.81)	C25	P1	D9	—	<b>16300*</b>	

"b" dimension is body O.D. • accommodates cable diameter ▲ distributor stocked \* recognized under the component program of U.L., Inc.  
■ includes outer ferrule

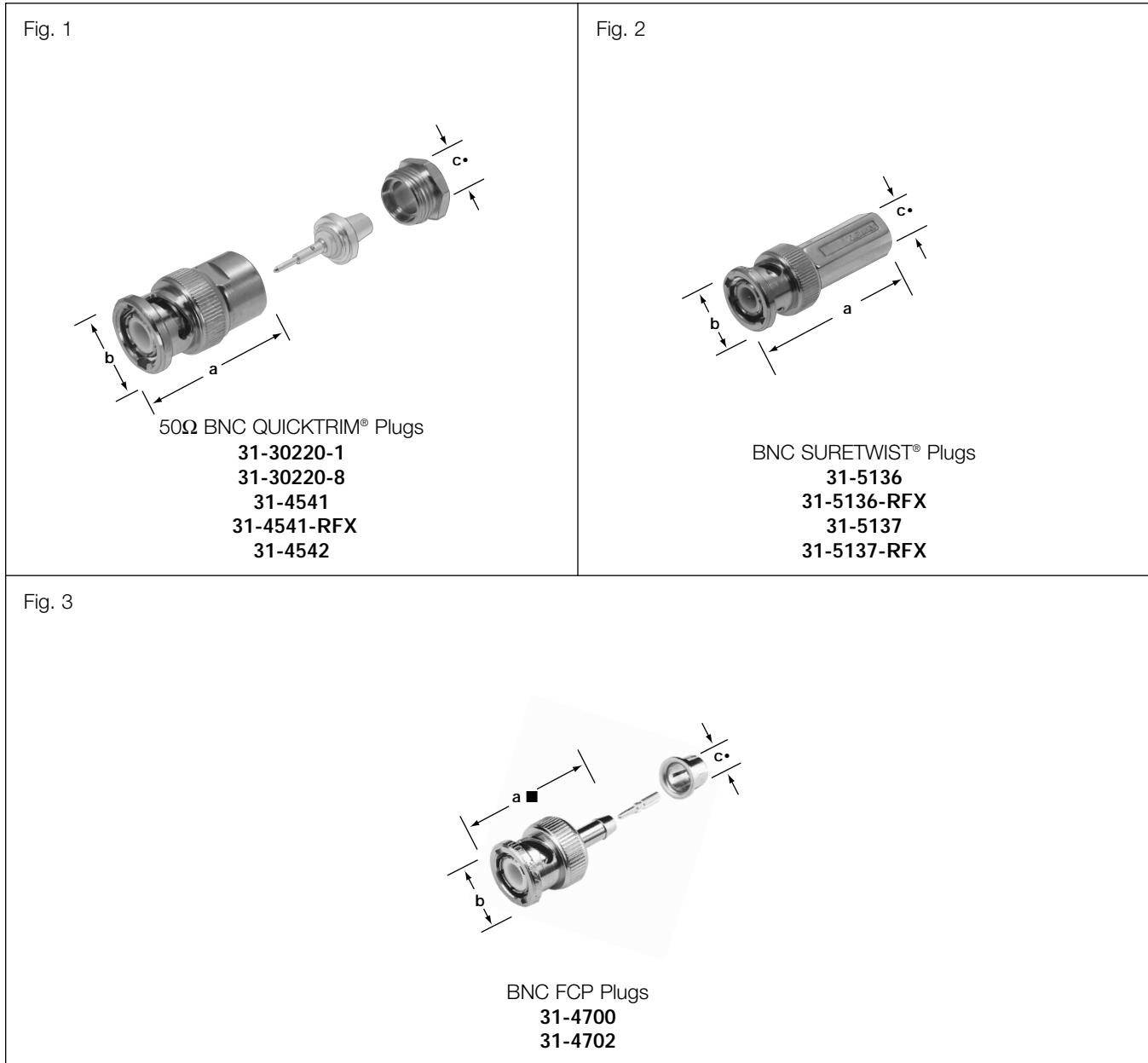

## BNC CABLE PLUGS

Cable RG-/U	Cable Attachment		Dimensions, inches (millimeters)			Notes			Military Number	Amphenol Number	Fig.
	Outer	Inner	a ■	b	c •	CAI	Plt.	Ins.			
58 B/U	SURETWIST®		1.47(37.3)	.562(14.3)	.181(4.6)	C28	P5	D15	—	<a href="#">31-5137</a>	2 ▲
	SURETWIST®		1.48(37.6)	.571(14.5)	.185(4.7)	C28	P7	D23	—	<a href="#">31-5137-RFX</a>	2 ▲
58	FCP	Pliers	1.06(27.0)	.563(14.3)	.206(5.23)	C30	P1	D1	—	<a href="#">31-4700*</a>	3 ▲
	QUICKTRIM®		1.06(27.0)	.563(14.3)	.207(5.3)	C29	P1	D1	—	<a href="#">31-30220-1</a>	1 ▲
59	QUICKTRIM®		1.03(26.2)	.562(14.3)	.252(6.2)	C29	P1	D1	(IBM 1836444)	<a href="#">31-4541</a>	1 ▲
	QUICKTRIM®		1.03(26.2)	.562(14.3)	.252(6.2)	C29	P7	D23	—	<a href="#">31-4541-RFX</a>	1 ▲
	SURETWIST®		1.47(37.3)	.562(14.3)	.242(6.1)	C28	P5	D15	—	<a href="#">31-5136</a>	2 ▲
	SURETWIST®		1.48(37.6)	.571(14.5)	.242(6.1)	C28	P7	D23	—	<a href="#">31-5136-RFX</a>	2 ▲
	FCP	Pliers	1.06(27.0)	.563(14.3)	.259(6.56)	C30	P1	D1	—	<a href="#">31-4702*</a>	3 ▲
223	QUICKTRIM®		1.06(27.0)	.563(14.3)	.225(5.7)	C29	P1	D1	—	<a href="#">31-30220-8</a>	1
Belden 9268	QUICKTRIM®		1.06(27.0)	.563(14.3)	.275(6.99)	C29	P1	D1	(IBM 1836447)	<a href="#">31-4542</a>	1

• accommodates cable diameter \* recognized under the component program of U.L., Inc. ▲ distributor stocked ■ includes outer ferrule

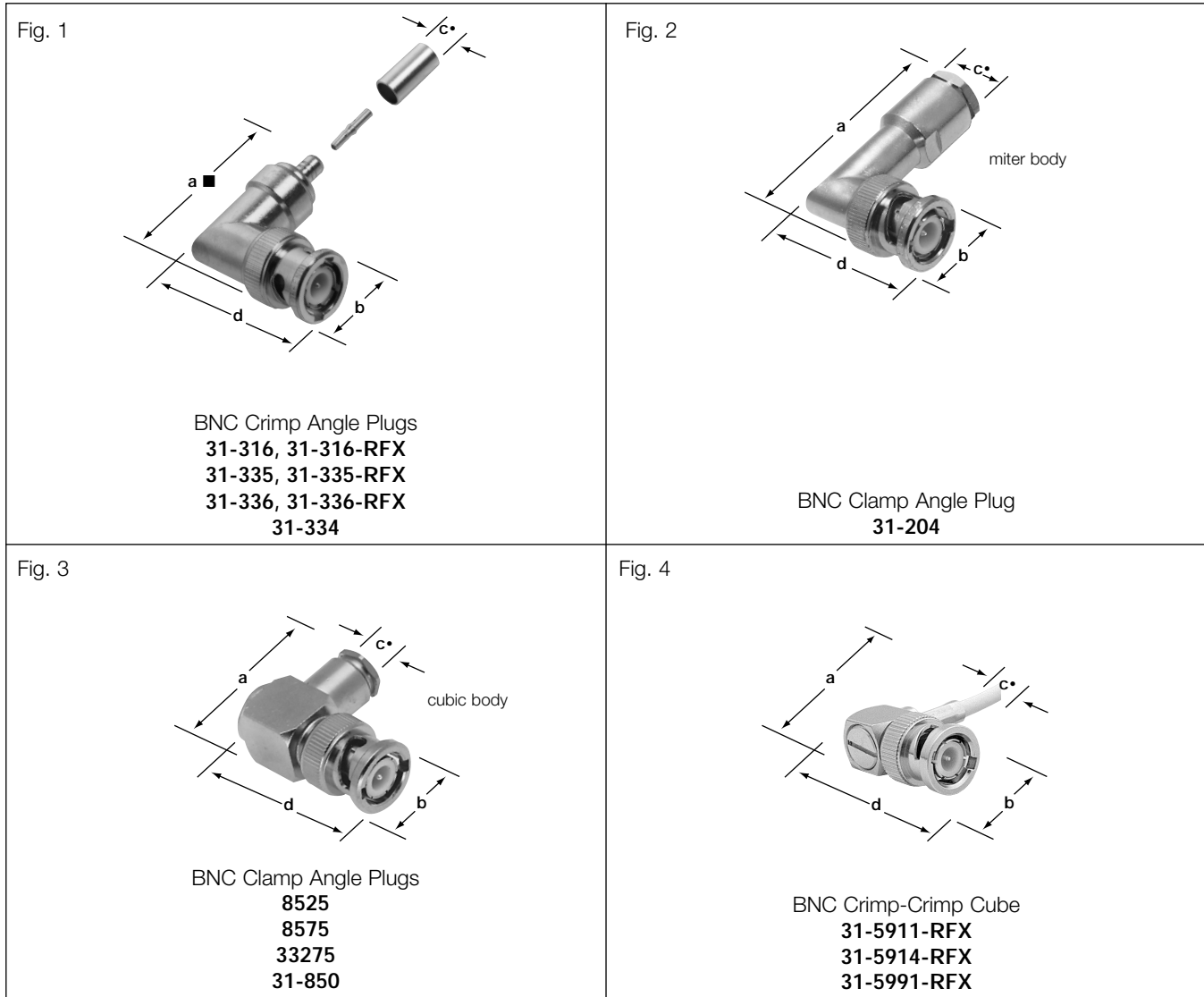

## BNC ANGLE CABLE PLUGS

Cable RG-/U	Cable Attachment		Dimensions, inches (millimeters)				Notes			Military Number	Amphenol Number	Fig.
	Outer	Inner	a	b	c •	d	CAI	Plt.	Ins.			
55, 58, 141, 142, 223, 400	Clamp	Solder	1.68(42.7)■	.562(14.3)	.214(5.5)	1.09(27.8)	C25	P1	D1	UG-913/U	31-204*	2
55, 142, 223, 400	Crimp	Crimp	1.59(30.2)■	.562(14.3)	.220(5.6)	1.19(40.5)	C26a	P15	D1	—	31-334*	1 ▲
58, 141	Crimp	Crimp	1.59(40.5)■	.562(14.3)	.206(5.2)	1.19(30.2)	C26a	P15	D1	—	31-335*	1
	Crimp	Crimp	1.66(42.2)■	.571(14.5)	.210(5.3)	1.07(27.2)	C26a	P7	D23	—	31-335-RFX	1
58, 141, 142, 400	Clamp	Solder	1.00(25.4)■	.562(14.3)	.212(5.4)	1.25(31.8)	C25	P1	D1	(Cubic Body)	8525*	3
59, 62, 71, 140, 210	Clamp	Solder	1.00(25.4)	.562(14.3)	.259(6.6)	1.25(31.8)	C25	P1	D1	—	8575*	3 ▲
	Clamp	Solder	1.25(31.6)	.562(14.3)	.259(6.6)	1.03(26.2)	C25	P1	D6	—	31-850*	3 ▲
59, 62, 140, 210	Crimp	Crimp	1.59(40.5)■	.562(14.3)	.259(6.6)	1.19(30.2)	C26a	P15	D1	—	31-336	1
	Crimp	Crimp	1.66(42.2)■	.571(14.5)	.260(6.6)	1.07(27.2)	C26a	P7	D23	—	31-336-RFX	1
174, 179, 187, 188	Clamp	Solder	1.25(31.6)	.562(14.3)	.115(2.9)	1.00(25.4)	C25	P1	D1	(Cubic Body)	33275*	3 ▲
174, 188, 316	Crimp	Crimp	1.19(30.2)■	.562(14.3)	.115(2.9)	1.59(40.5)	C26a	P15	D1	—	31-316*	1
58, 141	Crimp	Solder	.862(21.9)	.571(14.5)	.214(5.5)	1.07(27.2)	C26a	P7	D23	(Cubic Body)	31-5911-RFX	4
59	Crimp	Solder	.862(21.9)	.571(14.5)	.259(6.6)	1.07(27.2)	C26a	P7	D23	(Cubic Body)	31-5914-RFX	4
316	Crimp	Solder	.862(21.9)	.571(14.5)	.115(2.9)	1.09(27.8)	C26a	P7	D23	(Cubic Body)	31-5991-RFX	4
316 Die Cast	Crimp	Solder	.862(21.9)	.571(14.5)	.115(2.9)	1.07(27.2)	C26a	P7	D23	(Cubic Body)	31-316-RFX	1

■ includes outer ferrule • accommodates cable diameter \* recognized under the component program of U.L., Inc. ▲ distributor stocked

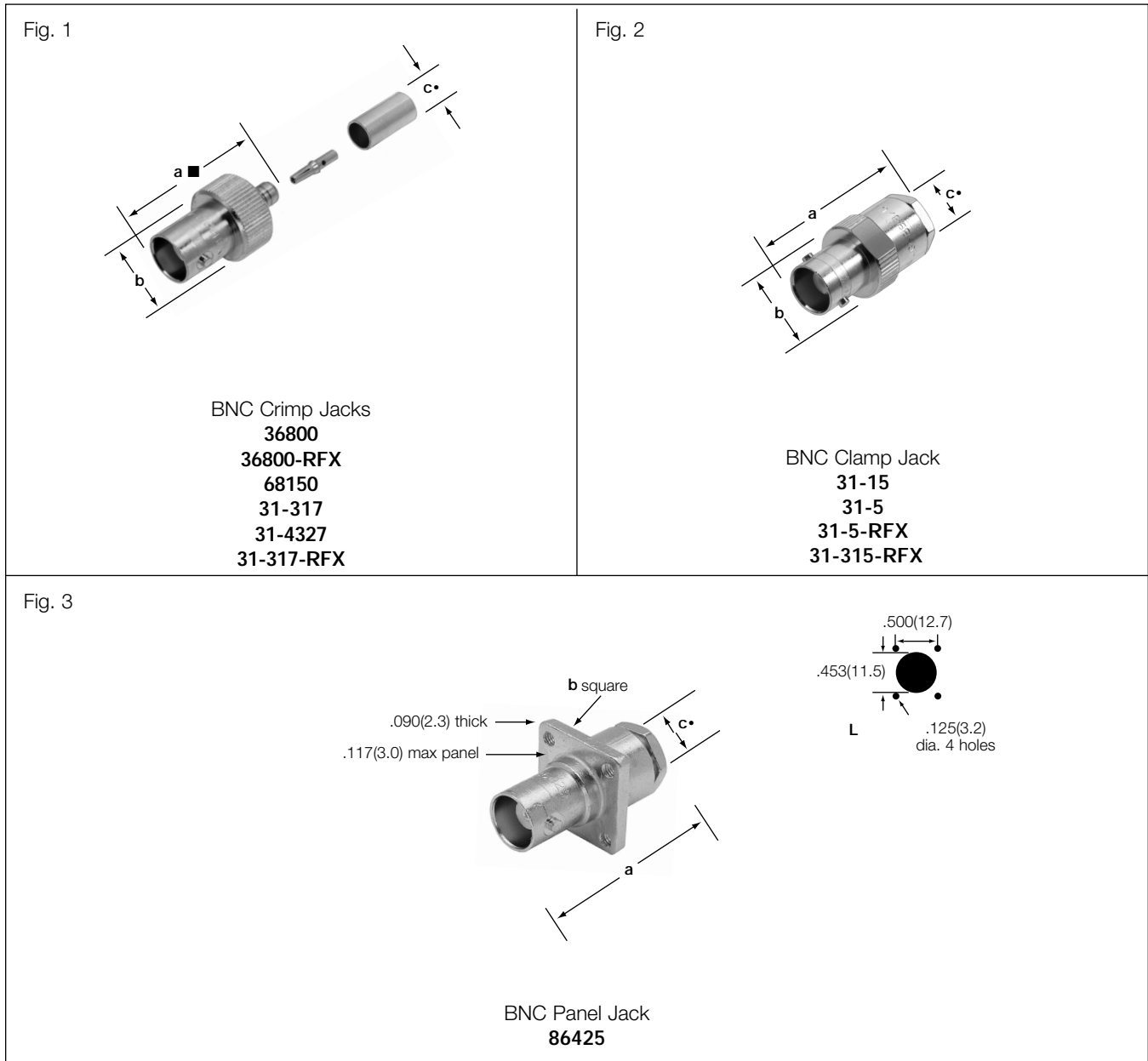

## BNC CABLE JACKS

Cable RG/U	Cable Attachment		Dimensions, inches (millimeters)			Construction Notes			Military Number	Amphenol Number	Fig.
	Outer	Inner	a ■	b	c •	CAI	Plt.	Ins.			
58, 141	Crimp	Crimp	1.17(29.8)	.562(14.3)	.206(5.2)	C26a	P33	D1	M39012/17-0013	31-4327*	1
	Crimp	Crimp	1.17(29.7)	.510(13.0)	.206(5.2)	C26a	P15	D1	—	36800*	1
	Crimp	Crimp	1.32(33.5)	.435(11.0)	.210(5.3)	C26a	P7	D23	—	36800-RFX	1
59, 62, 71, 140, 210	Clamp	Solder	1.14(29.0)	.562(14.3)	.259(6.6)	C25	P1	D1	UG-261/U	31-15*	2 ▲
174, 188, 316	Crimp	Crimp	1.19(30.2)	.571(14.5)	.106(2.7)	C26a	P15	D23	—	31-315-RFX	2
223	Clamp	Solder	1.14(29.0)	.562(14.3)	.220(5.0)	C25	P1	D1	UG-89/U	31-5	2 ▲
174, 188, 316	Crimp	Crimp	1.07(27.3)	.453(11.5)	.106(2.7)	C26a	P15	D23	—	31-317-RFX	1
174, 188, 316	Crimp	Crimp	1.39(35.3)	.562(14.3)	.125(3.2)	C26a	P15	D1	—	31-317*	1
174, 179, 187, 188, 316	Clamp	Solder	1.14(29.0)	.687(17.5)	.117(3.0)	C25	P1	D1	—	86425*	3
59, 62, 140, 210	Crimp	Crimp	1.18(30.0)	.510(13.0)	.261(6.6)	C26a	P15	D1	—	68150*	1 ▲
223	Clamp	Clamp	1.14(29.0)	.562(14.3)	.220(5.0)	C25	P1	D1	—	31-5-RFX	2

• accommodates cable diameter \* recognized under the component program of U.L., Inc. ▲ distributor stocked ■ includes outer ferrule

Fig. 1

BNC Crimp Bulkhead Jacks

<b>95700</b>	<b>31-318-RFX</b>
<b>31-245</b>	<b>31-342</b>
<b>31-245-RFX</b>	<b>31-342-RFX</b>
<b>31-318</b>	<b>31-343-1002</b>
<b>31-318-1001</b>	<b>31-343-RFX</b>

Fig. 2

BNC Clamp Bulkhead Jacks

<b>86350</b>
<b>86850</b>
<b>31-206</b>
<b>31-207</b>

## BNC BULKHEAD CABLE JACKS

Cable RG-/U	Cable Attachment		Dimensions, inches (millimeters)					CAI	Plt.	Ins.	Mtg. Hole	Military Number	Amphenol Number	Fig.
	Outer	Inner	a ■	b	c •	d	e							
55, 142, 223	Crimp	Crimp	1.41(35.8)	.795(20.2) dia	.220(5.6)	.812(20.6)	.250(6.4)	C26a	P17	D1	Y	—	95700*	1
58, 141	Crimp	Crimp	1.41(35.7)	.795(20.2) dia	.206(5.2)	.812(20.6)	.250(6.4)	C26a	P15	D1	Y	—	31-342	1 ▲
58, 141, 142, 223	Crimp	Crimp	1.38(35.1)	.687(17.5) hex	.210(5.3)	.709(18.0)	.138(3.5)	C26a	P7	D23	Y	—	31-342-RFX	1 ▲
58, 141, 142, 400	Clamp	Solder	1.12(28.6)	.687(17.6) hex	.224(5.7)	.798(20.3)	.218(5.5)	C25	P1	D1	Y	UG-909/U	31-206*	2
59, 62, 140, 210	Clamp	Solder	1.12(28.6)	.687(17.6) hex	.257(6.5)	.798(20.3)	.218(5.5)	C25	P1	D1	Y	UG-910/U	31-207*	2
	Crimp	Crimp	1.38(35.1)	.687(17.5) hex	.260(6.6)	.709(18.0)	.138(3.5)	C26a	P7	D23	Y	—	31-343-RFX	1
Plenum 59 (20 AWG)	Crimp	Crimp	1.41(35.8)	.795(20.2) dia	.220(5.6)	.812(20.6)	.250(6.4)	C26a	P15	D1	Y	—	31-343-1002	1
174,179,187,188,316	Clamp	Solder	1.14(29.0)	.687(17.5) hex	.115(2.9)	.798(20.3)	.250(6.4)	C25	P1	D1	Y	—	86350*	2 ▲
174, 188, 316	Crimp	Crimp	1.48(37.0)	.795(20.2) dia	.120(3.0)	.812(20.6)	.250(6.4)	C26a	P16	D1	Y	—	31-318*	1 ▲
	Crimp	Crimp	1.43(36.4)	.687(17.5) hex	.106(2.7)	.812(20.6)	.138(3.5)	C26a	P7	D23	Y	—	31-318-RFX	1 ▲
178, 196	Clamp	Solder	1.14(29.0)	.687(17.5) dia	.098(2.5)	.798(20.3)	.250(6.4)	C25	P1	D1	Y	—	86850*	2
179, 187	Crimp	Crimp	1.49(37.8)	.795(20.2) dia	.120(3.0)	.812(20.6)	.250(6.4)	C26a	P15	D1	Y	—	31-245*	1
	Crimp	Crimp	1.43(36.3)	.687(17.4) hex	.106(2.7)	.709(18.0)	.138(3.5)	C26a	P7	D23	Y	—	31-245-RFX	1
Dbl. Br. 316	Crimp	Crimp	1.41(35.8)	.795(20.2) dia	.135(3.42)	.812(20.6)	.250(6.4)	C26a	P15	D1	Y	—	31-318-1001	1

● accommodates cable diameter \* recognized under the component program of U.L., Inc. ▲ distributor stocked ■ includes outer ferrule



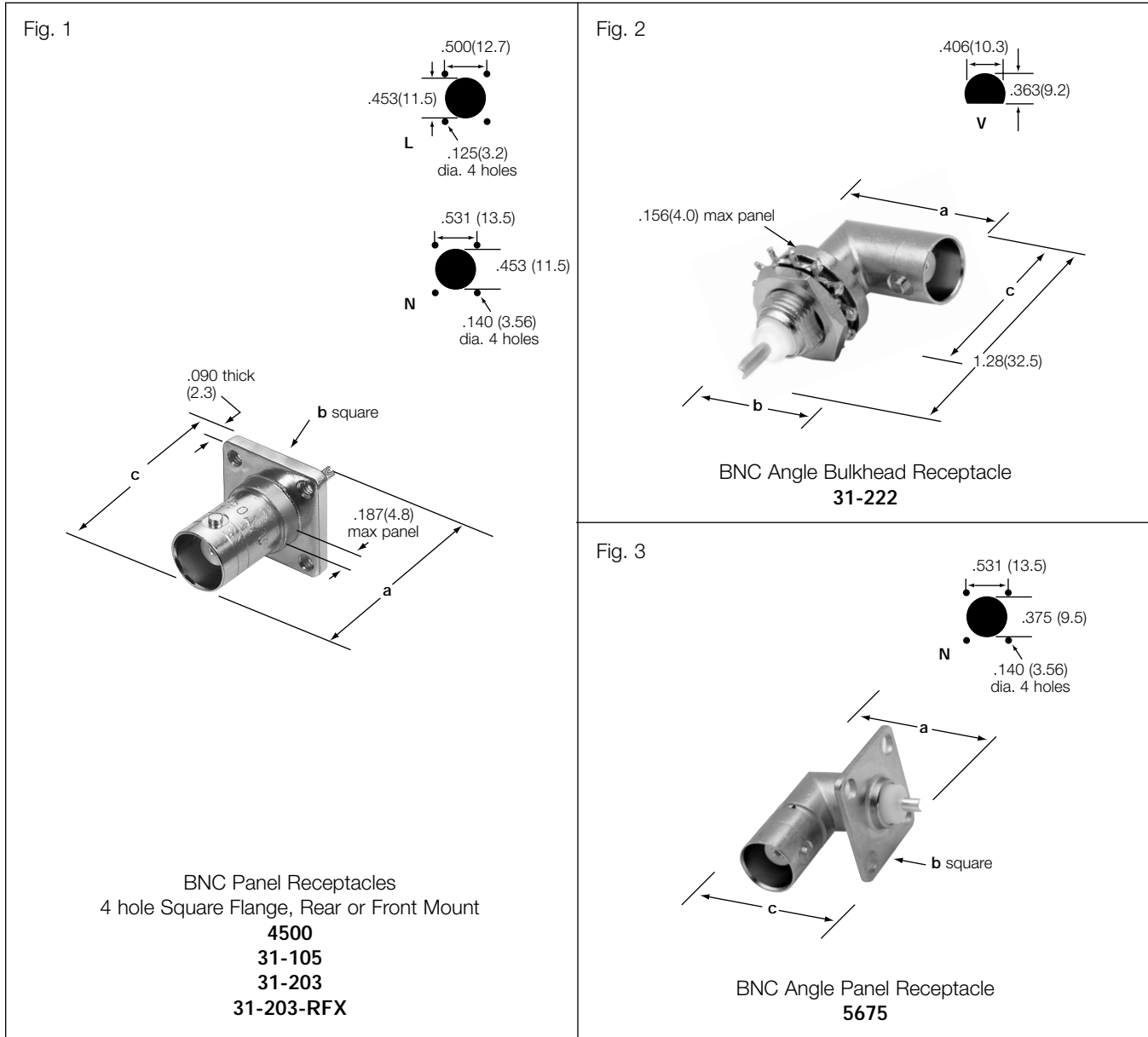

## BNC PANEL AND ANGLE BULKHEAD RECEPTACLES

Description	Terminal Type	Dimensions, inches (millimeters)			Notes		Mtg. Hole	Military Number	Amphenol Number	Fig.
		a	b	c	Plt.	Ins.				
Panel Receptacle 4 hole Square Flange No. 3-56 Tapped Flange Holes	Solder Cup	1.06(27.0)	.687(17.5)	.719(18.3)	P1	D1	L	UG-290A/U	<b>31-203</b>	1
Panel Receptacle 4 hole Square Flange .125" Dia. Flange Holes	Solder Cup	1.06(27.0)	.687(17.5)	.719(18.3)	P7	D23	L	—	<b>31-203-RFX</b>	
Panel Receptacle 4 hole Square Flange .120" Dia. Flange Holes, Styrene Ins.	Solder Cup	1.03(26.2)	.687(17.5)	.719(18.3)	P1	D6	L	—	<b>31-105*</b>	
Panel Receptacle 4 hole Square Flange .136" Dia. Flange Holes, Styrene Ins.	Turret	1.08(27.4)	.750(19.1)	.609(15.5)	P1	D6	N	UG-185/U	<b>4500*</b>	2
Angle, External Tooth Lockwasher	Solder Cup	.906(23.0)	.594(15.1)	.625(15.8)	P1	D1	V	UG-1098/U	<b>31-222*</b> □	
Angle Panel Receptacle 4 hole Flange .136"(3.5mm) Diameter Holes	Solder Cup	.928(23.6)	.642(16.3)	.642(16.3)	P1	D1	N	UG-535/U	<b>5675*</b>	3

\* recognized under the component program of U.L., Inc.    ▲ distributor stocked    □ IBM 01620666

# BNC 50 ohm Bulkhead Receptacles

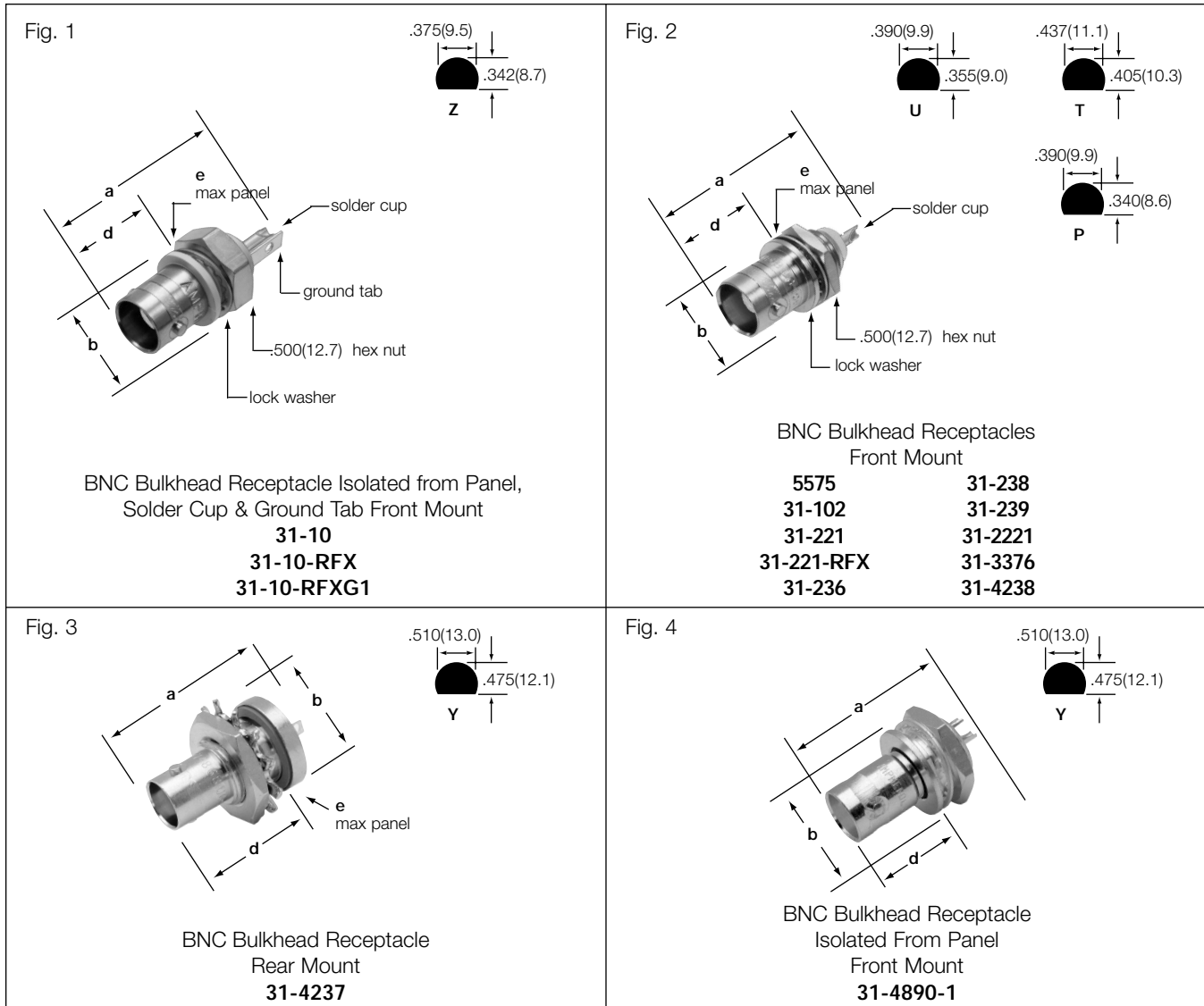

## BNC BULKHEAD RECEPTACLES

Description	Terminal Type	Dimensions, inches (mm)				Notes		Mtg. Hole	Military Number	Amphenol Number	Fig.
		a	b	d	e	Plt.	Ins.				
Front Mount, Isolated from Panel	Solder Cup	1.19(30.2)	.500(12.7)	.471(12.0)	.187(4.8)	P1	D22	Z	—	<b>31-10*</b>	1 ▲
	Solder Cup	1.18(30.0)	.500(12.7)	.471(12.0)	.125(3.2)	P1	D22	Z	—	<b>31-10-RFX</b>	1 ▲
Front Mount	Solder Cup	1.18(30.0)	.500(12.7)	.471(12.0)	.187(4.8)	P7	D22	Z	—	<b>31-10-RFXG1</b>	1 ▲
Front Mount	Solder Cup	1.06(27.0)	.500(12.7)	.484(12.3)	.125(3.2)	P1	D1	U	UG-1094/U	<b>31-221*†</b>	2 ▲
		1.06(27.0)	.500(12.7)	.472(12.0)	.125(3.2)	P7	D23	U	—	<b>31-221-RFX</b>	2 ▲
		1.06(27.0)	.500(12.7)	.469(11.9)	.156(4.0)	P1	D1	T	UG-625B/U	<b>31-236*</b>	2 ▲
		1.19(30.2)	.500(12.7)	.481(12.3)	.250(6.4)	P1	D1	U	UG-1094A/U	<b>31-2221</b>	2
Front Mount, Gold Plated Contact	Solder Cup	1.19(30.2)	.500(12.7)	.484(12.3)	.250(6.4)	P34	D1	U	M39012/21-0002	<b>31-3376*</b>	2
Front Mount, Pressurized	Solder Cup	1.30(32.9)	.578(14.7)	.594(15.1)	.250(6.4)	P1	D9	P	UG-657A/U	<b>31-239*</b>	2 ▲
Front Mount, Pressurized	Solder Cup	1.30(32.9)	.578(14.7)	.594(15.1)	.250(6.4)	P1	D9	P	UG-657/U	<b>31-102*</b>	2
Fr. Mount, Gold Plated Contact	Spade	1.20(30.6)	.594(15.1)	.516(13.1)	.250(6.4)	P33	D1	U	M39012/24-0002	<b>31-4238*</b>	2
Hermetic External Tooth Lockwasher	Spade	1.20(30.6)	.594(15.1)	.516(13.1)	.250(6.4)	P1	D1/11	U	UG-912/U	<b>31-238*</b>	2
Front Mount	Solder Cup	1.06(27.0)	.500(12.7)	.472(12.0)	.156(4.0)	P1	D1	T	UG-625/U	<b>5575*</b>	2 ▲
Rear Mount, Hermetic	Spade	1.34(34.0)	.687(17.4)	.831(21.1)	.250(6.4)	P33	D1/11	Y	M39012/24-0001	<b>31-4237*</b>	3
Front Mount Isolated from Panel Metal Mounting Threads	Solder Cup	1.06(27.0)	.625(15.9)	.571(14.5)	.187(4.7)	P4	D1	Y	—	<b>31-4890-1</b>	4

\* recognized under the component program of U.L., Inc. ▲ distributor stocked † includes grounding lug

Fig. 1

Standard Height 50 ohm BNC Printed Circuit Board Right Angle Bulkhead Receptacles ☆

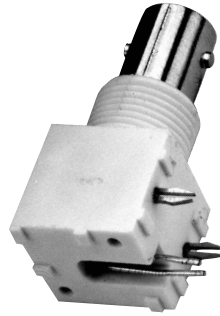
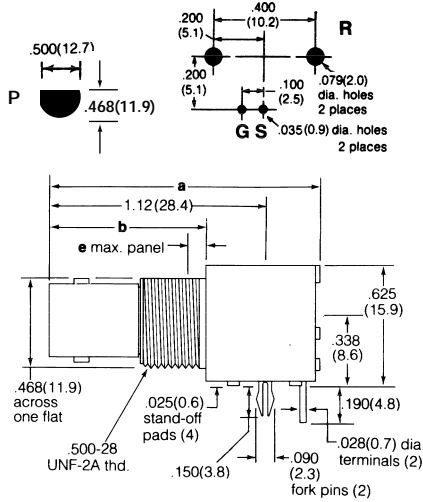

Isolated from Panel  
White Valox Housing  
**31-5431▲** (Round Pins)  
**31-5431-1010** (Fork Pins)  
**31-5431-10RFX**

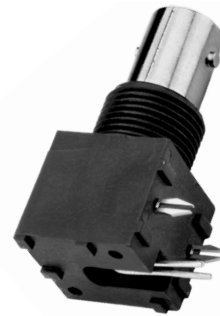

Isolated from Panel  
Black Valox Housing  
**31-5538** (Round Pins)  
**31-5538-1010** (Fork Pins)  
**31-5538-10RFX**

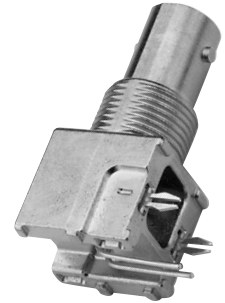

Metal Housing  
**31-5640▲** (Round Pins)  
**31-5640-1010** (Fork Pins)

Fig. 2

Low Profile 50 ohm BNC Printed Circuit Board Bulkhead Receptacles ☆

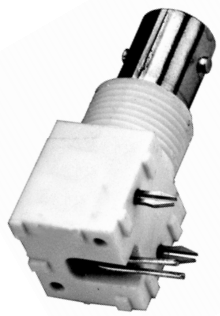
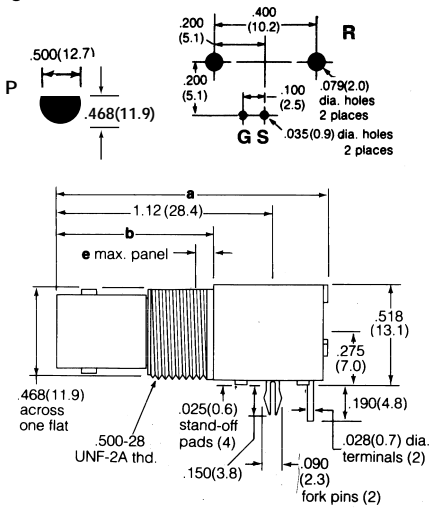

Isolated from Panel  
White Valox Housing  
**31-5486▲** (Round Pins)  
**31-5486-1010** (Fork Pins)  
**31-5486-10RFX**

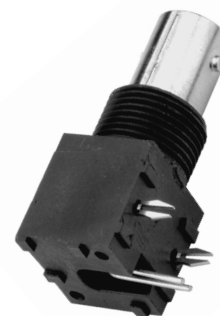

Isolated from Panel  
Black Valox Housing  
**31-5540** (Round Pins)  
**31-5540-1010** (Fork Pins)  
**31-5540-10RFX**



Metal Housing  
**31-5637** (Round Pins)

Fig. 3

Vertical 50 ohm BNC Printed Circuit Board Bulkhead Receptacles ☆

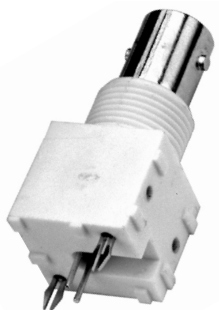
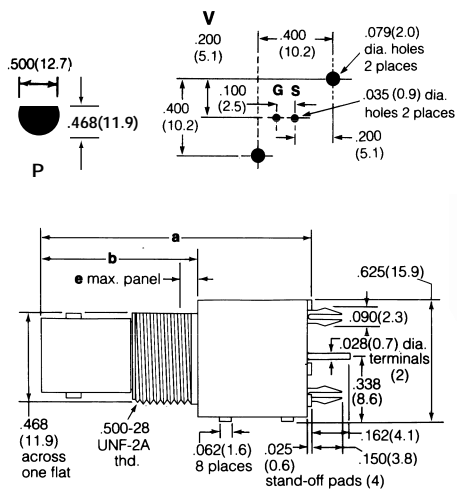

Isolated from Panel  
White Valox Housing  
**31-5493▲** (Round Pins)  
**31-5493-1010** (Fork Pins)



Isolated from Panel  
Black Valox Housing  
**31-5539** (Round Pins)  
**31-5539-1010▲** (Fork Pins)  
**31-5539-10RFX**



Metal Housing  
**31-5633** (Round Pins)  
**31-5633-1010** (Fork Pins)

▲ distributor stocked ☆ Jam nuts and lockwashers sold separately.

# BNC 50 ohm PCB Receptacles and Accessories

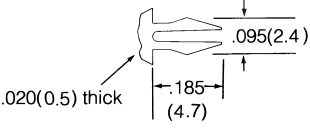
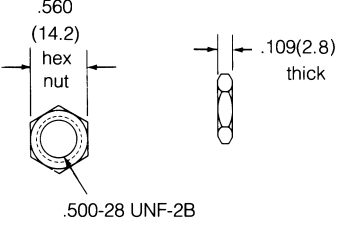
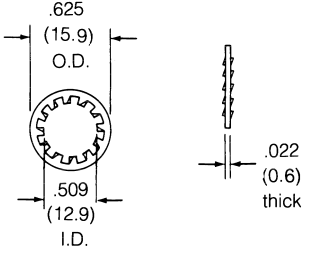
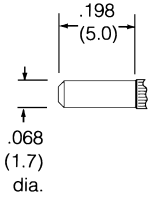
 <p>Fork Pin holds connectors rigidly to P.C. Board for high temperature and mass production assembly</p>	<p>Fig. 4</p>  <p>Pkg. of 100, Hex Nut for BNC Bulkhead PCB Receptacles <b>31-5652▲</b> Nickel Plated</p>	<p>Fig. 5</p>  <p>Pkg. of 100, Lockwasher for BNC PCB Bulkhead Receptacles <b>31-5653▲</b> Nickel Plated</p>
 <p>Round Pin (Standard)</p>		

## BNC PRINTED CIRCUIT BOARD BULKHEAD RECEPTACLES AND ACCESSORIES

Description	Terminal Type	Dimensions, inches (millimeters)			Notes		Mtg. Hole	Notes	MTG. Pin Type	Imp	Amphenol Number	Fig.
		a	b	e	Plt.	Ins.						
Standard Height Printed Circuit Angle Bulkhead Receptacle (J)☆	Blunt Posts for Signal & Ground	1.40(35.6)	.810(20.6)	.250(6.4)	P26	D17	R/P	Iso. White Housing	Round	50Ω	<a href="#">31-5431</a>	1 ▲
					P26	D17	Fork		50Ω	<a href="#">31-5431-1010</a>		
					P26	D20	R/P	Iso. Black Housing	Round	50Ω	<a href="#">31-5538</a>	1 ▲
					P26	D20	Stamp		50Ω	<a href="#">31-5538-10RFX</a>		
					P26	D22	R/P	Metal Housing	Round	50Ω	<a href="#">31-5640</a>	1 ▲
					P26	D22	Fork		50Ω	<a href="#">31-5640-1010</a>		
					P25	D17	R/P	Iso. White Housing	Fork	50Ω	<a href="#">31-5431-10RFX</a>	1 ▲
Low Profile Printed Circuit Angle Bulkhead Receptacle (J)☆	Blunt Posts for Signal & Ground	1.40(35.6)	.810(20.6)	.250(6.4)	P26	D17	R/P	Iso. White Housing	Round	50Ω	<a href="#">31-5486</a>	2 ▲
					P26	D17	Fork		50Ω	<a href="#">31-5486-1010</a>		
					P26	D20	R/P	Iso. Black Housing	Round	50Ω	<a href="#">31-5540</a>	2 ▲
					P26	D20	Fork		50Ω	<a href="#">31-5540-1010</a>		
					P26	D22	R/P	Metal Housing	Round	50Ω	<a href="#">31-5637</a>	2 ▲
P26	D22	Fork	50Ω	<a href="#">31-5637-1010</a>								
Vertical Printed Circuit Bulkhead Receptacle (J)☆	Blunt Posts for Signal & Ground	1.40(35.6)	.810(20.6)	.250(6.4)	P26	D17	V/P	Iso. White Housing	Round	50Ω	<a href="#">31-5493</a>	3 ▲
					P26	D17			Fork	50Ω	<a href="#">31-5493-1010</a>	
					P26	D20	V/P	Iso. Black Housing	Round	50Ω	<a href="#">31-5539</a>	3 ▲
					P26	D20			Fork	50Ω	<a href="#">31-5539-1010</a>	
					P26	D22	V/P	Metal Housing	Round	50Ω	<a href="#">31-5633</a>	3 ▲
					P26	D22			Fork	50Ω	<a href="#">31-5633-1010</a>	
					P25	D13	R/P	Iso. White Housing	Fork	50Ω	<a href="#">31-5486-10RFX</a>	2 ▲
					P25	D20	R/P	Iso. Black Housing	Fork	50Ω	<a href="#">31-5540-10RFX</a>	2 ▲
Hex Nut for BNC Bulkhead PCB Receptacles, Package of 100 ea.					P3	—	—	Nickel Plated	—	—	<a href="#">31-5652</a>	4 ▲
Lockwasher for BNC Bulkhead PCB Receptacles, Package of 100 ea.					P3	—	—	Nickel Plated	—	—	<a href="#">31-5653</a>	5 ▲

☆ Jam nuts and lockwashers sold separately. See Figs. 4 & 5 ▲ distributor stocked

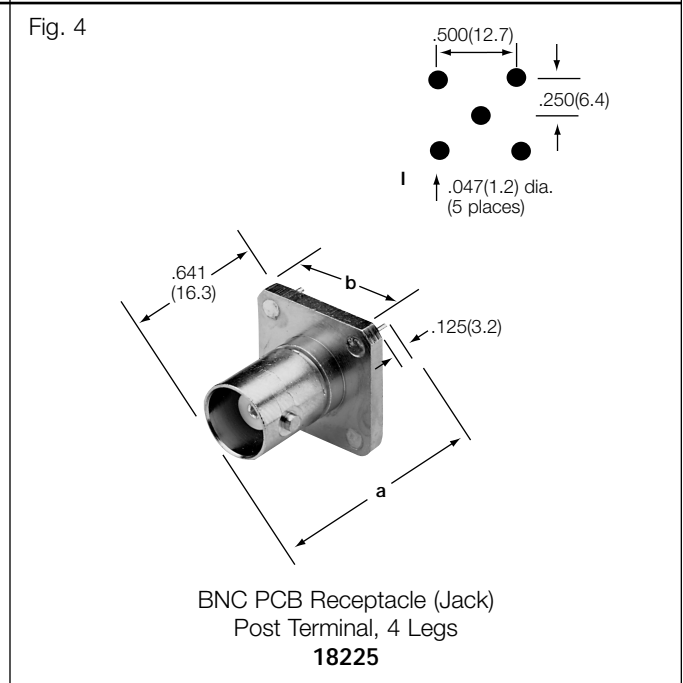
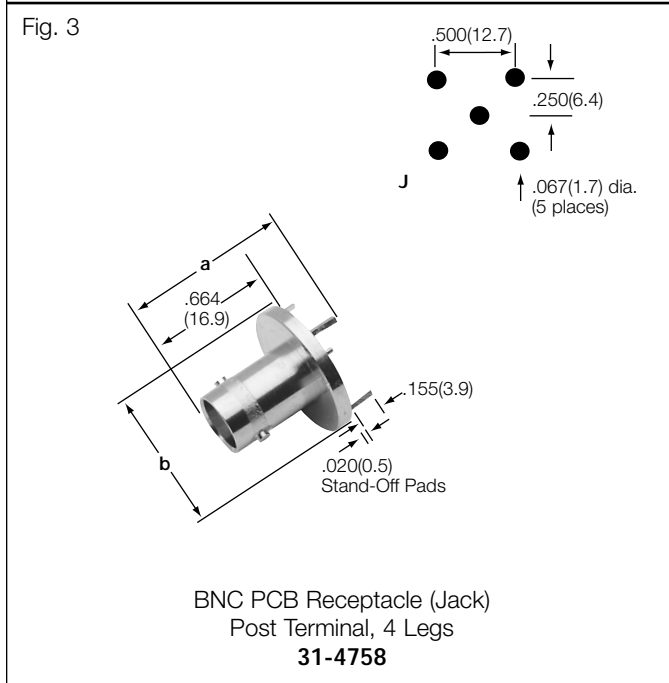
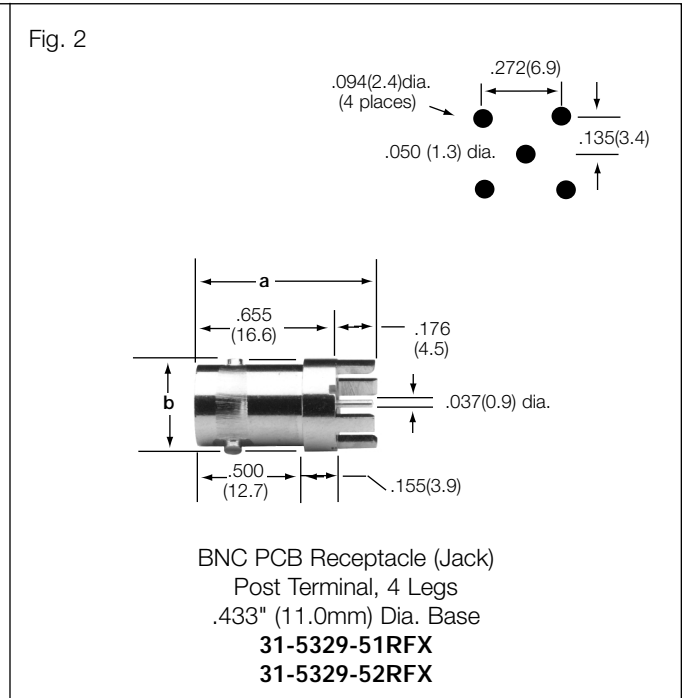
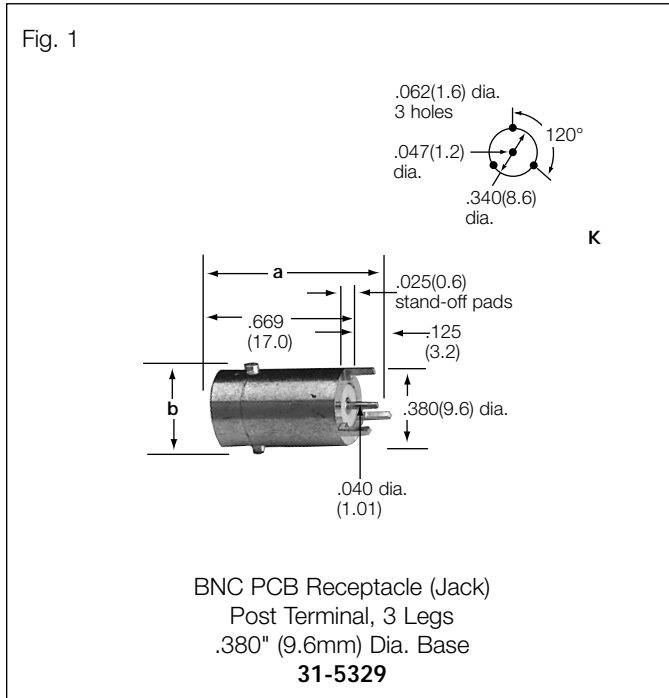

## PRINTED CIRCUIT BOARD RECEPTACLES

Description	Terminal Type	Dimensions, inches (mm)		Notes			Mtg. Hole	Amphenol Number	Fig.
		a	b	Plt.	Ins.	Imp.			
PCB Receptacle, 3 Legs .125(3.2) Long/Post Terminal .040(1.0) Dia. x .125(3.2) Long/.025(0.6) Stand-off Pads	Blunt Post	.794(20.2)	.434(11.0)	P6	D1	50Ω	K	<b>31-5329</b>	1
PCB Receptacle, 4 Legs .176(4.5) Long/Post terminal .037(0.9) Dia. Silver Contact	Blunt Post	.831(21.1)	.433(11.0) dia	P1	D25	50Ω	F	<b>31-5329-51RFX</b>	2 ▲
PCB Receptacle, 4 Legs .176(4.5) Long/Post terminal .037(0.9) Dia. Gold Contact	Blunt Post	.831(21.1)	.433(11.0) dia	P17	D25	50Ω	F	<b>31-5329-52RFX</b>	2 ▲
PCB Receptacle, 4 Legs .155(3.9) Long/.020(0.5) Stand-off Pads/Post terminal .040(1.0) Dia.	Blunt Post	.819(20.8)	.812(20.6) dia	P1	D1	50Ω	J	<b>31-4758</b>	3
PCB Receptacle, 4 Legs and Post Terminal .040(1.0) Dia. x .125(3.2) Long	Blunt Post	.766(19.4)	.688(17.5) dia	P1	D1	50Ω	I	<b>18225</b>	4

▲ distributor stocked



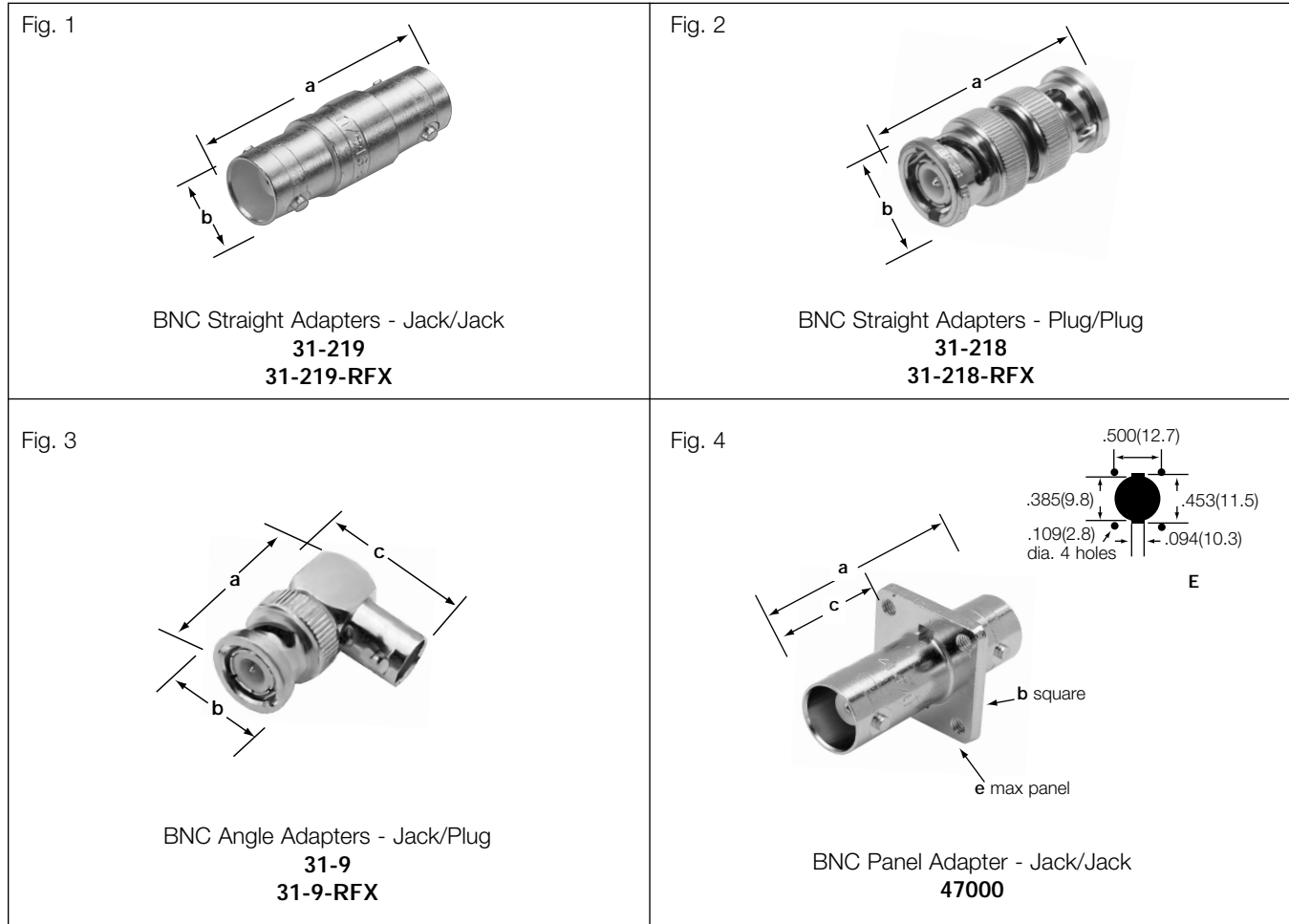

BNC

## BNC ADAPTERS - STRAIGHT, ANGLE, PANEL MOUNT

Description		Dimensions, inches (millimeters)				Notes		Mtg. Hole	Military Number	Amphenol Number	Fig.
		a	b	c	e	Plt.	Ins.				
Straight	Jack-Jack	1.28(32.5)	.437(11.1)	—	—	P1	D1	—	UG-914/U	<b>31-219*</b>	1 ▲
						P7	D26	—	—	<b>31-219-RFX</b>	1 ▲
Straight	Plug-Plug	1.25(31.8)	.562(14.3)	—	—	P1	D1	—	UG-491A/U	<b>31-218*</b>	2 ▲
						P7	D1	—	—	<b>31-218-RFX</b>	2 ▲
Angle	Jack-Plug	1.06(27.0)	.562(14.3)	1.02(25.8)	—	P1	D1	—	UG-306/U	<b>31-9*‡</b>	3 ▲
		1.06(27.0)	.562(14.3)	1.02(25.8)	—	P1	D1	—	—	<b>31-9-RFX</b>	3 ▲
		1.09(27.6)	.594(15.1)	1.02(25.8)	—	P34	D1	—	M55339/14-00306	<b>31-4561</b>	3
Panel, 3-56 Tapped Flange Holes	Jack-Jack	1.28(32.5)	.688(17.5)	.691(17.6)	.250(6.4)	P1	D1	E	—	<b>47000*</b>	4

\* recognized under the component program of U.L., Inc. ▲ distributor stocked ‡ IBM 6028521

Fig. 1

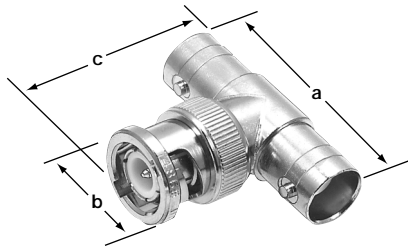

Tee Adapters - Jack-Plug-Jack  
**31-208**  
**31-208-RFX**  
**31-208-1051**  
**31-2208**

Fig. 2

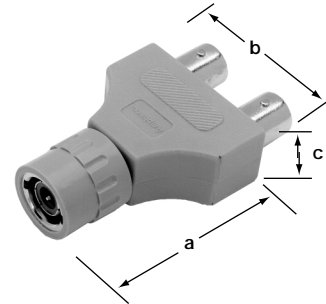

BNC Overmolded Tee Adapter  
 Jack-Plug-Jack  
**31-5693**

Fig. 3

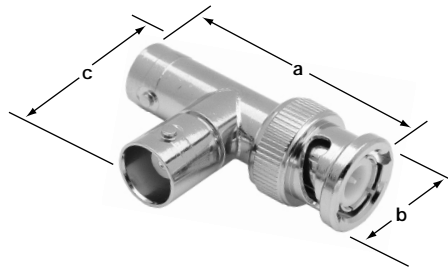

BNC Tee Adapter  
 Plug-Jack-Jack  
**21900**

## BNC TEE ADAPTERS

Description		Dimensions, inches (millimeters)			Notes		Military Number	Amphenol Number	Fig.
		a	b	c	Plt.	Ins.			
Tee	Jack-Plug-Jack	1.28(32.5)	.562(14.3)	1.06(27.0)	P1	D1	UG-274A/U	<a href="#">31-208*</a>	1 ▲
Tee	Jack-Plug-Jack	1.30(33.0)	.571(14.5)	1.04(26.3)	P7	D23	—	<a href="#">31-208-RFX</a>	1 ▲
Tee	Jack-Plug-Jack	1.28(32.5)	.562(14.3)	1.06(27.0)	P15	D1	—	<a href="#">31-208-1051</a>	1
Tee	Jack-Plug-Jack	1.28(32.5)	.562(14.3)	1.06(27.0)	P4	D1	UG-274B/U	<a href="#">31-2208*</a>	1
Tee, Overmolded	Jack-Plug-Jack	1.72(43.6)	1.32(33.5)	.550(14.0)	P7	D14	—	<a href="#">31-5693</a>	2 ▲
Tee	Plug-Jack-Jack	1.53(38.9)	.375(9.52)	1.00(25.4)	P1	D9	—	<a href="#">21900*</a>	3

\* recognized under the component program of U.L, Inc. ▲ distributor stocked

Fig. 1

BNC Bulkhead Adapters - Jack/Jack  
**4525**  
**31-220G-RFX**  
**31-220H**  
**31-220N**  
**31-220N-RFX**  
**31-3220**

Fig. 2

BNC Isolated Bulkhead Adapters  
 Jack-Jack  
**31-4803**  
**31-4803-1101**  
**31-4803-RFX**

BNC

## BNC BULKHEAD ADAPTERS

Description		Dimensions, inches (millimeters)				Notes		Mtg. Hole	Military Number	Amphenol Number	Fig.	
		a	b	c	e	Pit.	Ins.					
Sealed, 50 PSI	Jack-Jack	1.40(35.6)	.687(17.45)	.683(17.3)	.187(4.8)	P1	D1	Y	UG-492A/U	<b>31-220H</b> *‡	1	▲
	Jack-Jack	1.53(38.9)	.688(17.5)	.672(17.0)	.281(7.1)	P4	D1	Y	UG-492D/U	<b>31-3220*</b>	1	▲
Gasketed	Jack-Jack	1.56(39.6)	.689(17.5)	.681(17.3)	.295(7.5)	P7	D23	Y	—	<b>31-220G-RFX</b>	1	▲
	Jack-Jack	1.40(35.6)	.800(20.3)	.659(16.7)	.160(4.1)	P1	D1	Y	—	<b>4525*</b>	1	▲
Non-sealed	Jack-Jack	1.40(35.6)	.800(20.3)	.664(16.9)	.187(4.8)	P1	D1	Y	—	<b>31-220N</b>	1	▲
		1.28(32.5)	.610(15.5)	.492(12.5)	.216(5.5)	P7	D23	Y	—	<b>31-220N-RFX</b>	1	▲
Isolated from Panel	Jack-Jack	1.28(32.5)	.625(15.9)	.460(11.7)	.187(4.8)	P1	D12	Y	—	<b>31-4803</b>	2	▲
		1.28(32.5)	.625(15.9)	.460(11.7)	.187(4.8)	P15	D12	Y	—	<b>31-4803-1101</b>	2	
		1.28(32.5)	.625(15.9)	.460(11.7)	.187(4.8)	P15	D12	Y	—	<b>31-4803-RFX</b>	2	

\* recognized under the component program of U.L, Inc. ▲ distributor stocked ‡ IBM 5252764

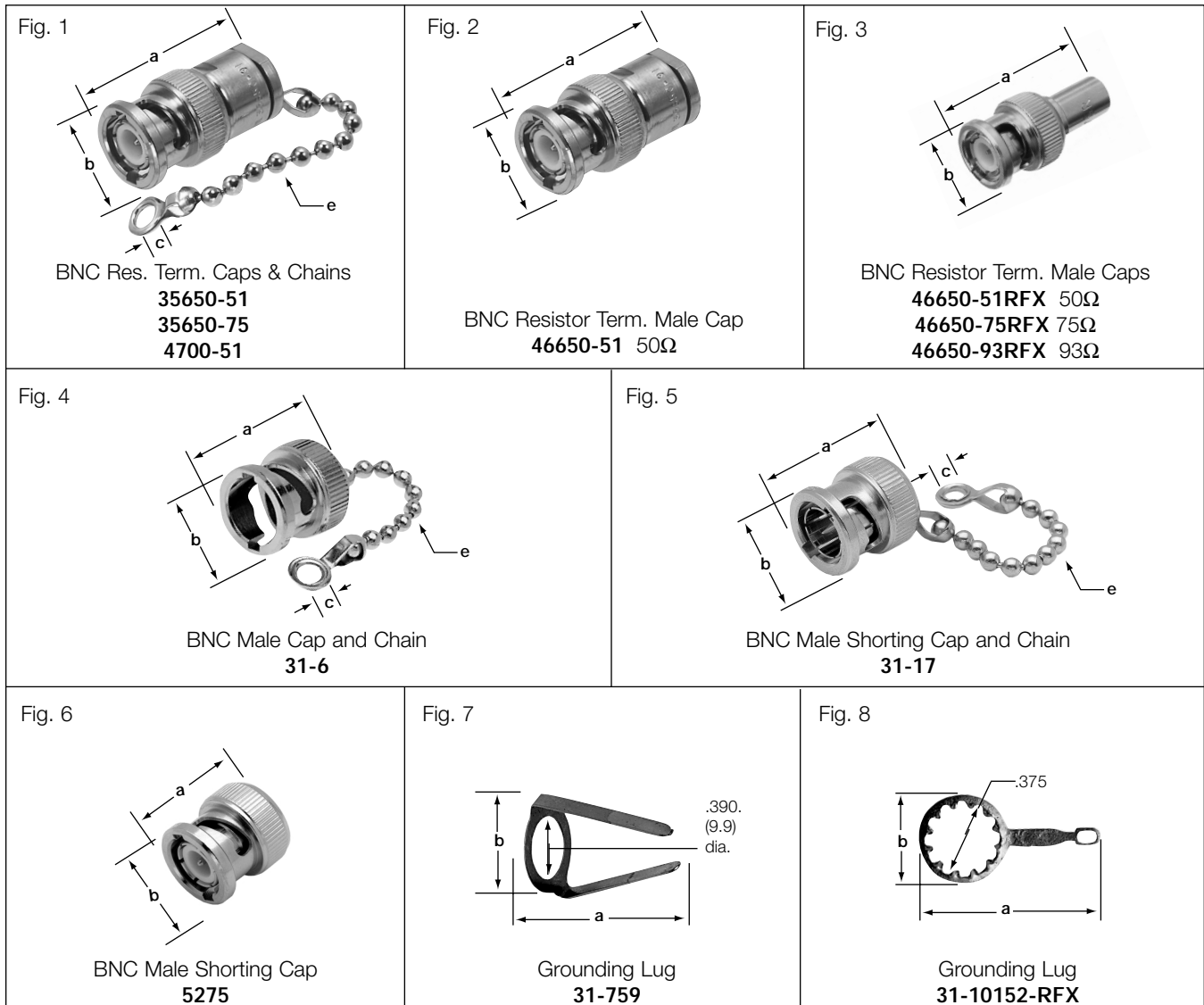

## BNC CAPS & ACCESSORIES

Description	Dimensions, inches (millimeters)				Notes		Military Number	Amphenol Number	Fig.	
	a	b	c	e	Plt.	Ins.				
Male Cap & Chain Resistor Terminated, 1% 1/2watt	50Ω	1.19(30.2)	.562(14.3)	.144(3.7)	3.50(88.9)	P1	D1	—	35650-51*	1
	75Ω					P1	D1	—	35650-75*	1
	51Ω					P1	D6	MX-554	4700-51*	1
Male Cap, Resistor Terminated, 1% 1 watt	51Ω	1.12(28.6)	.562(14.3)	—	—	P1	D1	—	46650-51*	2
Male Cap, Resistor Terminated, 1% 1 watt	50Ω	1.11(28.1)	.571(14.5)	—	—	P1	D23	—	46650-51RFX	3
	75Ω								46650-75RFX	3
	93Ω								46650-93RFX	3
Male Cap & Chain		.688(17.5)	.563(14.3)	.130(3.3)	2.25(57.2)	P3	—	CW-123/U	31-6*	4
Male Shorting Cap & Chain		.688(17.5)	.563(14.3)	.144(3.7)	2.50(63.5)	P1	—	CW-159/U	31-17*	5
Male Shorting Cap		.594(15.1)	.563(14.3)	—	—	P1	—	—	5275*	6
Pkg. of 25 Lugs Used Inside Panel on Front Mount Bulkhead Receptacles to Ground Cable Shield*		.961(24.4)	.578(14.7)	—	—	P3	—	(IBM 2245373)	31-759*	7
Pkg. of 25 Lugs Used Inside Panel on Front Mount Bulkhead Receptacles for Ground Wire to Circuit		1.156(29.4)	.578(14.7)	—	—	P8	—	—	31-10152-RFX*	8

■ IBM 3110787 \* recognized under the component program of U.L., Inc. ▲ distributor stocked

**Description**

To meet the need for higher performance, impedance matched cable interconnections, Amphenol offers a full line of 75 ohm BNC connectors. These connectors can be used in a variety of applications where true 75 ohm performance is needed to insure lower signal distortion.



**Features/Benefits**

Designed for the most popular 75 ohm cables used in broadcast and CATV applications as well as for plenum cables and others — these connectors feature crimp-crimp cable affixment for quick and reliable installation.

Two distinct types of 75Ω BNCs are available. Both types mate with each other and with 50Ω BNCs.

- Type 1 is designated 75Ω BNC-T1 and provides constant 75Ω performance with low VSWR DC to 4 GHz.
- Type 2 is designated 75Ω BNC-T2 and is usable with low reflection DC to 1 GHz. For applications above 1 GHz, Type 1 is recommended.

**Applications**

- Broadcast
- Satellite TV Earth Stations
- Telecommunications
- LAN
- Test and Measurement
- Security Transmission Systems
- Telecom
- Computer Networks
- HDTV

**75 ohm**

75 ohm Connectors	123
BNC Plugs and Jacks	125-132
Adapters	133-134



## ELECTRICAL

Impedance	75 ohms nominal
Frequency range	0-4 GHz
Voltage rating	500 volts rms
Dielectric withstanding voltage	1,500 volts rms.
Insulation resistance	5,000 megohms min.
VSWR	Type 1: 1.5 + 0.1 f(GHz) DC to 4 GHz Type 2: 1.00 + 0.25 f(GHz) DC to 1 GHz

\* These characteristics are typical and may not apply to all connectors.

## MATERIAL

Body, coupling sleeve, male contact	Brass
Female contact	Beryllium copper or phosphor bronze
Crimp ferrule	Copper alloy
Plating	Contacts: gold Other metal parts: Nickel

## MECHANICAL

Mating	2-stud bayonet lock
Cable affixment	Crimp-Crimp

## ENVIRONMENTAL

Temperature range	TFE insulators: - 65°C to + 165°C Copolymer of Styrene: - 55°C to + 85°C
Weatherproof	Clamps with clamp gaskets. Crimps with heat-shrink tubing.
Hermetic seals	Pass helium leak test of 2 X 10 <sup>-8</sup> cc/sec
Shock	MIL-Std. 202 method 202
Vibration	MIL-Std. 202 method 204 (test cond. D)
Moisture resistance	MIL-Std. 202 method 106
Corrosion	MIL-Std. 202 method 101 (test cond. B)
Temperature cycling	MIL-Std. 202 method 102 (test cond. D)
Altitude	MIL-Std. 202 method 105 (test cond. C)

## PLUG

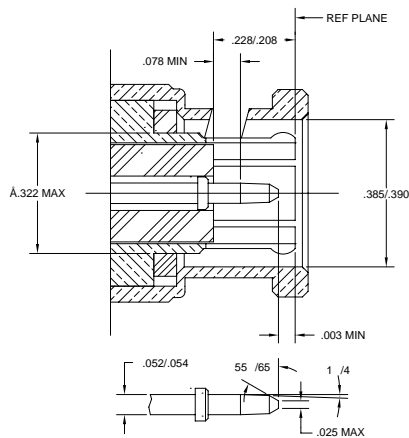

## JACK

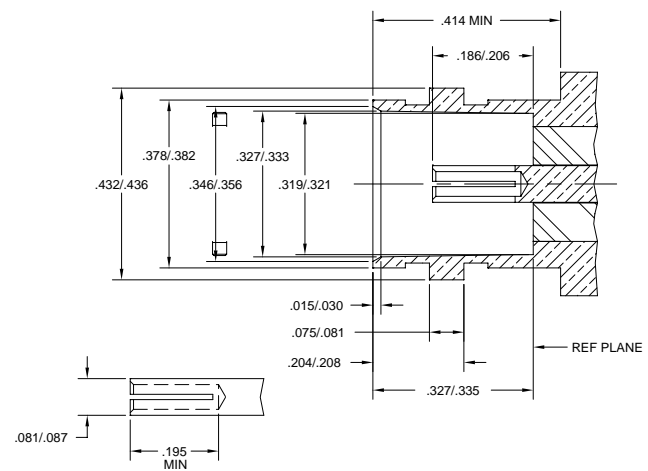
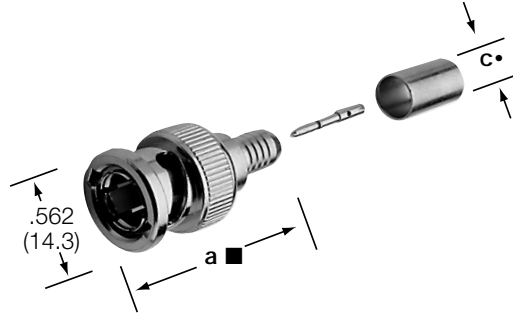

Fig. 1



75Ω BNC Crimp Plugs

31-70000	31-70222	31-71008	31-71013-1000
31-70000-1000	31-70234	31-71008-1000	31-71032
31-70008	31-70235	31-71008-2000	31-71033
31-70008-1000	31-70236	31-71008-1RFX	31-71034
31-70008-3000	31-70237	31-71008-RFX	31-71035
31-70013	31-70238	31-71013	31-71064
31-70013-1000	31-71000-RFX	31-71013-RFX	31-71065
			31-71066

## 75Ω BNC PLUGS AND ANGLE PLUGS

Cable RG-/U	Connector Configuration	Cable Attachment		Dimensions, inches (millimeters)			Notes			75Ω Type	Amphenol Number	Fig.
		Outer	Inner	a ■	c •	d	CAI	Plt.	Ins.			
RG-6 Type .295" O.D. max. Belden 9248, 1694A (Single Shield)	Plug	Crimp	Crimp	1.35(34.3)	.300(7.6)	—	C31	P15	D1	T1	31-70000☆	1 ▲
	Plug	Crimp	Crimp	1.21(30.7)	.300(7.6)	—	C32	P7	D26	T2	31-71000-RFX☆	1 ▲
	Plug	Crimp	Crimp	1.25(31.8)	.300(7.6)	—	C31	P15	D1	T1	31-70000-1000	1 ▲
	Plug	Crimp	Crimp	1.21(30.7)	.300(7.6)	—	C32	P15	D1	T2	31-71064	1 ▲
59, 62 Belden 8241, 8263, 8279, 9209	Plug	Crimp	Crimp	1.25(31.7)	.261(6.6)	—	C31	P16	D1	T1	31-70008	1 ▲
	Plug	Crimp	Crimp	1.12(28.6)	.261(6.6)	—	C32	P15	D1	T2	31-71008	1 ▲
	Plug	Crimp	Crimp	1.17(29.8)	.260(6.6)	—	C32	P7	D26	T2	31-71008-RFX	1 ▲
59 (20GA CC) Belden 1426A, 1505A 9100, 9278	Plug	Crimp	Crimp	1.25(31.8)	.261(6.6)	—	C31	P15	D1	T1	31-70008-3000	1 ▲
	Plug	Crimp	Crimp	1.12(28.5)	.261(6.6)	—	C32	P15	D1	T2	31-71008-1000	1 ▲
	Plug	Crimp	Crimp	1.17(29.8)	.261(6.6)	—	C32	P7	D26	T2	31-71008-1RFX	1 ▲
Plenum 59, Belden 88241 82259, 89259	Plug	Crimp	Crimp	1.11(28.2)	.220(5.6)	—	C32	P15	D1	T2	31-71008-2000	1 ▲
Plenum 59 (20GA CC) Belden 82108	Plug	Crimp	Crimp	1.11(28.2)	.220(5.6)	—	C32	P15	D1	T2	31-71035	1 ▲
DbI Shield 59 (20GA CC) 179, 187	Plug	Crimp	Crimp	1.36(34.5)	.334(8.5)	—	C31	P15	D1	T1	31-70222	1 ▲
DbI. Br. 179	Plug	Crimp	Crimp	1.33(33.5)	.120(3.0)	—	C31	P15	D1	T1	31-70013	1 ▲
	Plug	Crimp	Crimp	1.19(30.2)	.120(3.0)	—	C32	P15	D1	T2	31-71013	1 ▲
	Plug	Crimp	Crimp	1.19(30.2)	.106(2.7)	—	C32	P17	D23	T2	31-71013-RFX	1 ▲
ATT 728B, Belden 9231	Plug	Crimp	Crimp	1.25(31.7)	.175(4.4)	—	C31	P15	D1	T1	31-70013-1000	1 ▲
	Plug	Crimp	Crimp	1.11(28.2)	.175(4.4)	—	C32	P15	D1	T2	31-71013-1000	1 ▲
ATT 734A	Plug	Crimp	Crimp	1.36(34.5)	.342(8.7)	—	C31	P16	D1	T1	31-70022	1 ▲
Belden 8218	Plug	Crimp	Crimp	1.25(31.7)	.261(6.6)	—	C31	P15	D1	T1	31-70008-1000	1 ▲
Belden 8281, 88281	Plug	Crimp	Crimp	1.11 (28.2)	.175(4.4)	—	C32	P15	D1	T2	31-71033	1 ▲
Belden 89248, (Plenum)	Plug	Crimp	Crimp	1.21 (30.7)	.342(8.7)	—	C32	P15	D1	T2	31-71032	1 ▲
Belden 9290, 1152A (Double Shield)	Plug	Crimp	Crimp	1.35 (34.3)	.250 (6.4)	—	C31	P15	D1	T1	31-70000☆	1 ▲
Belden 89292	Plug	Crimp	Crimp	1.21 (30.7)	.314(8.0)	—	C32	P7	D26	T2	31-71000-RFX☆	1 ▲
	Plug	Crimp	Crimp	1.21 (30.7)	.314(8.0)	—	C32	P15	D1	T2	31-71065	1 ▲
Quad 59 Headend Cable Belden 1694	Plug	Crimp	Crimp	1.62 (41.1)	.418(10.6)	※	C32	P15	D1	T2	31-71034	1 ▲
Belden 8281	Plug	Crimp	Crimp	1.12 (28.6)	.287(7.3)	—	C32	P15	D1	T2	31-71066	1 ▲
Belden 8218	Plug	Crimp	Crimp	1.00(25.4)	.260(6.6)	—	C26a	P7	D1	T1	31-70234	1
Belden 734A	Plug	Crimp	Crimp	1.00(25.4)	.260(6.6)	—	C26a	P7	D1	T1	31-70235	1
Belden 735A	Plug	Crimp	Crimp	1.00(25.4)	.260(6.6)	—	C26a	P7	D1	T1	31-70236	1
	Plug	Crimp	Crimp	1.00(25.4)	.260(6.6)	—	C26a	P7	D1	T1	31-70237	1
	Plug	Crimp	Crimp	1.00(25.4)	.260(6.6)	—	C26a	P7	D1	T1	31-70238	1

• accommodates cable diameter ■ includes outer ferrule ☆ supplied with two crimp ferrules ▲ Distributor Stocked ※ OD = .590(15.0)

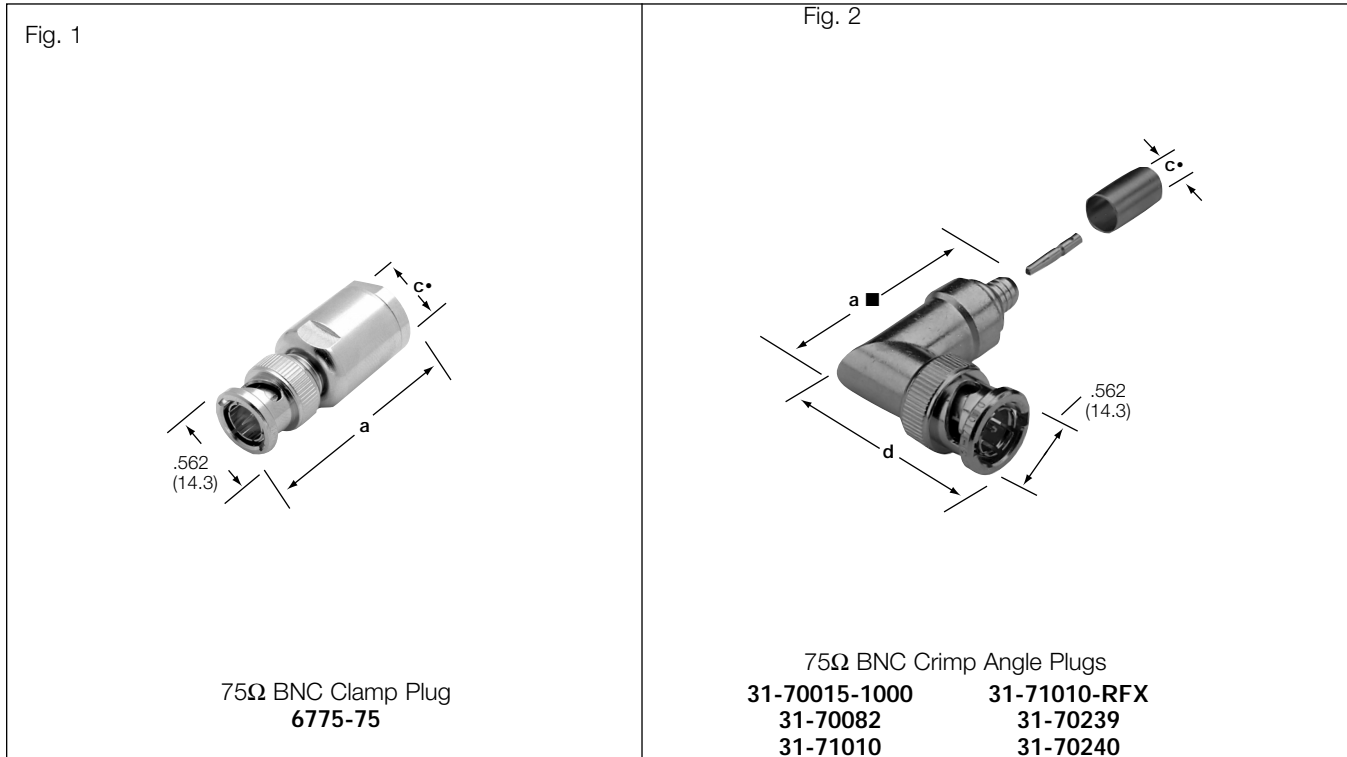

## 75Ω BNC PLUGS AND ANGLE PLUGS

Cable RG-/U	Connector Configuration	Cable Attachment		Dimensions, inches (millimeters)			Notes			75Ω Type	Amphenol Number	Fig.
		Outer	Inner	a ■	c •	d	CAI	Pit.	Ins.			
11	Plug	Clamp	Solder	1.75(44.4)	.443(11.2)	—	C25	P1	D1	T2	6775-75	1
59, 62 Belden 8241, 8263, 8279, 9209	Angle Plug	Crimp	Crimp	1.66(42.2)	.261(6.6)	1.24(31.5)	C32	P15	D1	T2	31-71010	2
	Angle Plug	Crimp	Crimp	1.66(42.2)	.260(6.6)	1.07(27.3)	C32	P7	D23	T2	31-71010-RFX	2
ATT 735A	Angle Plug	Crimp	Solder	1.09(27.7)	.158(4.0)	.894(22.7)	C31	P15	D1	T1	31-70082	2
ATT 19224-L2	Angle Plug	Crimp	Crimp	1.63(41.4)	.175(4.4)	1.24(31.5)	C31	P16	D1	T1	31-70015-1000	2
AT&T 734A†	Angle Plug	Crimp	Crimp	.571(14.5)	.295(7.5)	1.36(34.5)	C31	P7	D1	T1	31-70239	2
AT&T 735A†	Angle Plug	Crimp	Crimp	.571(14.5)	.295(7.5)	1.36(34.5)	C31	P7	D1	T1	31-70240	2

• accommodates cable diameter    ■ includes outer ferrule    ☆ supplied with two crimp ferrules    ▲ Distributor Stocked    \* OD = .590(15.0)    † Low Cost

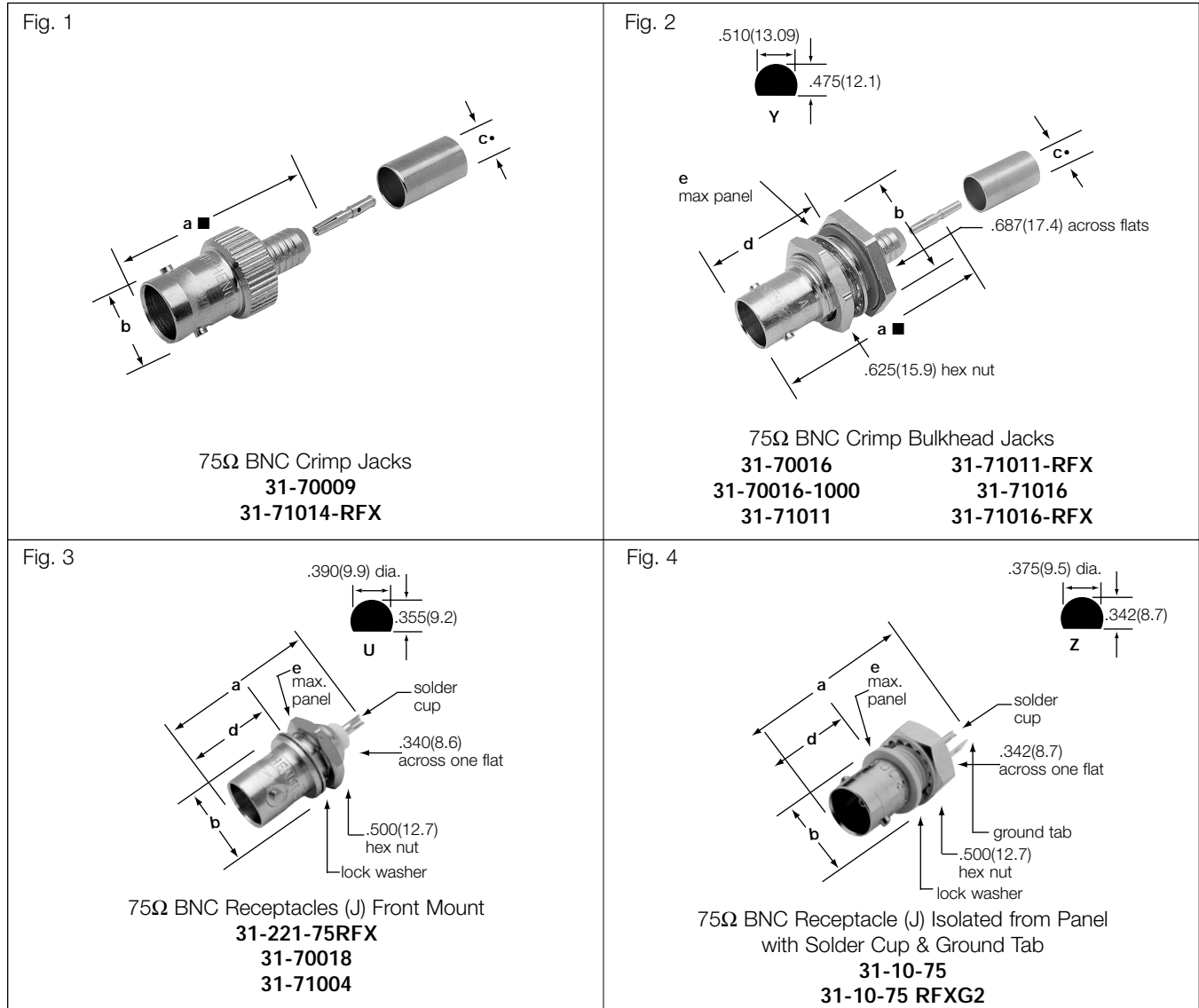

## 75Ω BNC JACKS & RECEPTACLES

Cable RG/U	Connector Type	Dimensions, inches (millimeters)					Notes			Mtg. Hole	75Ω Type	Amphenol Number	Fig.
		a ■	b	c ●	d	e	CAI	Plt.	Ins.				
59, Belden	Jack	1.18(30.0)	.510(12.9)	.261(6.6)	—	—	C31	P17	D1	—	T1	31-70009	1
8241, 8263	Bulkh. Jack	1.41(35.7)	.795(20.2)dia	.261(6.6)	.812(20.6)	.250(6.4)	C32	P15	D1	Y	T2	31-71011	2
59, 62, 140, 210	Bulkh. Jack	1.38(35.1)	.687(17.5)	.260(6.6)	.710(18.0)	.138(3.5)	C32	P7	D23	Y	T2	31-71011-RFX	2
179, 187	Jack	1.37(35.0)	.435(11.0)	.106(2.7)	—	—	C32	P7	D23	—	T2	31-71014-RFX	1
	Bulkh. Jack	1.48(37.7)	.687(17.4)hex	.120(3.0)	.812(20.6)	.250(6.4)	C31	P17	D1	Y	T1	31-70016	2
		1.41(35.7)	.795(20.2)dia	.120(3.0)	.812(20.6)	.250(6.4)	C32	P15	D1	Y	T2	31-71016	
1.43(36.4)	.687(17.4)hex	.106(2.7)	.710(18.0)	.138(3.5)	C32	P7	D23	Y	T2	31-71016-RFX	▲		
Dbl. Br. 179 ATT 19224-L2	Bulkh. Jack	1.48(37.7)	.687(17.4)hex	.175(4.4)	.812(20.6)	.250(6.4)	C31	P15	D1	Y	T1	31-70016-1000	2
Bulkhead Receptacle (J) Front Mount		1.06(27.0)	.490(12.4)	—	.472(12.0)	.125(3.2)	—	P15	D1	U	T2	31-71004	3
		1.06(27.0)	.490(12.4)	—	.472(12.0)	.250(6.4)	—	P15	D1	U	T1	31-70018	
		1.05(26.7)	.500(12.7)	—	.475(12.1)	.138(3.5)	—	P7	D23	U	T2	31-221-75RFX	
Bulkhead Receptacle (J) Frnt Mt, Iso. from Panel		1.19(30.2)	.490(12.4)	—	.472(12.0)	.187(4.7)	—	P15	D12	Z	T2	31-10-75	4
Bulkhead Receptacle (J) Frnt Mt, Iso. from Panel		1.19(30.2)	.490(12.4)	—	.472(12.0)	.187(4.7)	—	P7	D12	Z	T2	31-10-75-RFXG2	4

■ Includes outer ferrule ● accommodates cable diameter ▲ Distributor Stocked

Fig. 1

Standard Height BNC Printed Circuit Board Right Angle Bulkhead Receptacles ☆

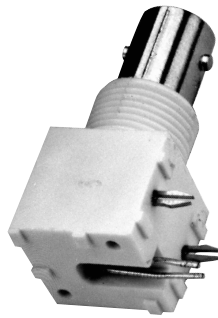
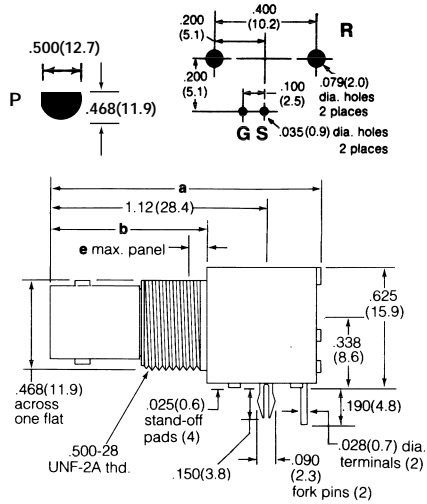

Isolated from Panel  
White Valox Housing  
**31-71047** (Round Pins)  
**31-71047-1010** (Fork Pins)

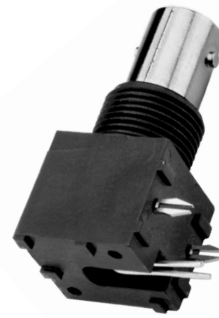

Isolated from Panel  
Black Valox Housing  
**31-71046** (Round Pins)  
**31-71046-1010** (Fork Pins)

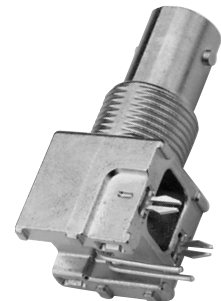

Metal Housing  
**31-71043** (Round Pins)  
**31-71043-1010▲**  
(Fork Pins)

Fig. 2

Low Profile BNC Printed Circuit Board Bulkhead Receptacles ☆

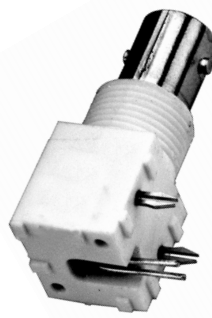
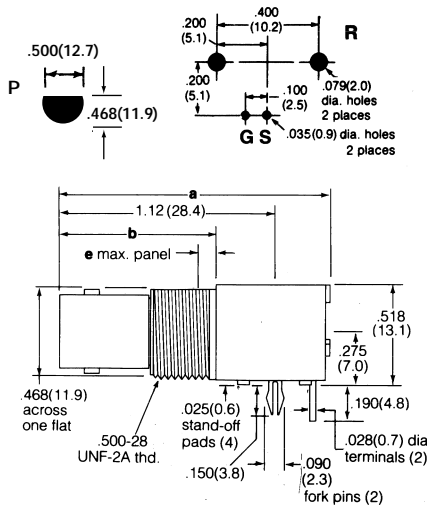

Isolated from Panel  
White Valox Housing  
**31-71052** (Round Pins)  
**31-71052-1010** (Fork Pins)  
**31-71052-10RFX**



Isolated from Panel  
Black Valox Housing  
**31-71053** (Round Pins)  
**31-71053-1010** (Fork Pins)



Metal Housing  
**31-71042** (Round Pins)

Fig. 3

Vertical BNC Printed Circuit Board Bulkhead Receptacles ☆

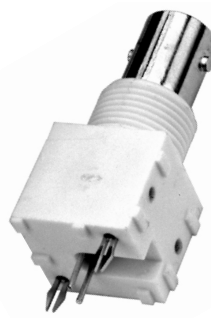
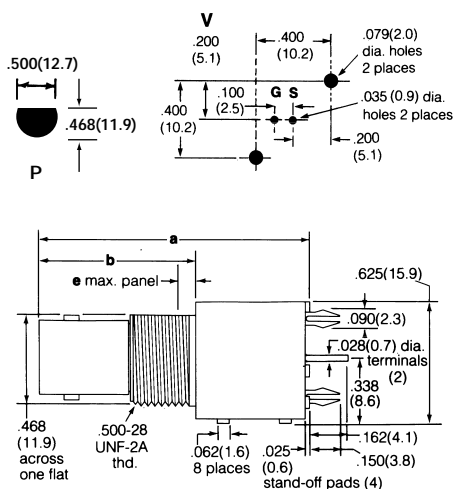

Isolated from Panel  
White Valox Housing  
**31-71058** (Round Pins)  
**31-71058-1010** (Fork Pins)



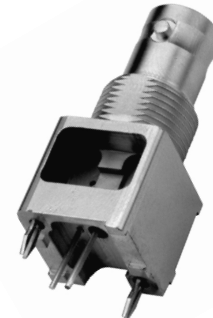

Isolated from Panel  
Black Valox Housing  
**31-71059** (Round Pins)  
**31-71059-1010** (Fork Pins)



Metal Housing  
**31-71045** (Round Pins)  
**31-71045-1010**  
(Fork Pins)

☆ Jam nuts and lockwashers sold separately. ▲ distributor stocked

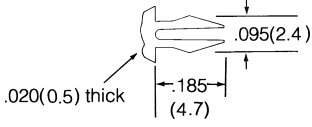
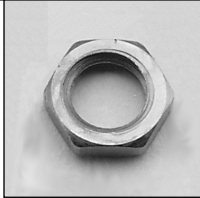
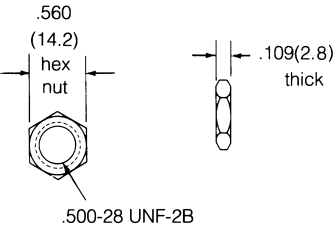

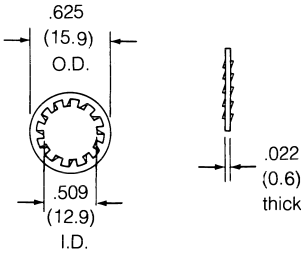
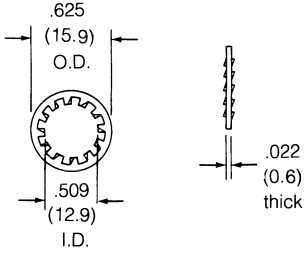
 <p>Fork Pin holds connectors rigidly to P.C. Board for high temperature and mass production assembly</p>	<p>Fig. 4</p>   <p>Pkg. of 100, Hex Nut for BNC Bulkhead PCB Receptacles <b>31-5652▲</b> Nickel Plated</p>	<p>Fig. 5</p>   <p>Pkg. of 100, Lockwasher for BNC PCB Bulkhead Receptacles <b>31-5653▲</b> Nickel Plated</p>
 <p>Round Pin (Standard)</p>		

## BNC PRINTED CIRCUIT BOARD BULKHEAD RECEPTACLES

Description	Terminal Type	Dimensions, inches (millimeters)			Notes		Mtg. Hole	Notes	Mtg. Pin Type	Imp	Amphenol Number	Fig.	
		a	b	e	Plt.	Ins.							
Standard Height Printed Circuit Angle Bulkhead Receptacle (J)☆	Blunt Posts for Signal & Ground	1.40(35.6)	.810(20.6)	.250(6.4)	P26	D17	R/P	Iso. White Housing	Round	75Ω	<b>31-71047</b>	1	
					P26	D17			Fork	75Ω			<b>31-71047-1010</b>
					▲	P26	D20	R/P	Iso. Black Housing	Round	75Ω		<b>31-71046</b>
										Fork	75Ω		<b>31-71046-1010</b>
										P26	D22		R/P
Fork	75Ω	<b>31-71043-1010</b>											
Low Profile Printed Circuit Angle Bulkhead Receptacle (J)☆	Blunt Posts for Signal & Ground	1.40(35.6)	.810(20.6)	.250(6.4)	P26	D17	R/P	Iso. White Housing	Round	75Ω	<b>31-71052</b>	2	
					P26	D17			Fork	75Ω	<b>31-71052-1010</b>		
					P26	D17			Fork	75Ω	<b>31-71052-10RFX</b>		
					P26	D20	R/P	Iso. Black Housing	Round	75Ω	<b>31-71053</b>		
									Fork	75Ω	<b>31-71053-1010</b>		
P26	D22	R/P	Metal Housing	Round	75Ω	<b>31-71042</b>							
Vertical Printed Circuit Bulkhead Receptacle (J)☆	Blunt Posts for Signal & Ground	1.40(35.6)	.810(20.6)	.250(6.4)	P26	D17	V/P	Iso. White Housing	Round	75Ω	<b>31-71058</b>	3	
					P26	D17			Fork	75Ω	<b>31-71058-1010</b>		
					P26	D20	V/P	Iso. Black Housing	Round	75Ω	<b>31-71059</b>		
									Fork	75Ω	<b>31-71059-1010</b>		
					P26	D22	V/P	Metal Housing	Round	75Ω	<b>31-71045</b>		
P26	D22	Fork	75Ω	<b>31-71045-1010</b>									
Hex Nut for BNC Bulkhead PCB Receptacles, Package of 100 ea.					P3	—	—	Nickel Plated	—	—	<b>31-5652</b>	4	
Lockwasher for BNC Bulkhead PCB Receptacles, Package of 100 ea.					P3	—	—	Nickel Plated	—	—	<b>31-5653</b>	5	

☆ Jam nuts and lockwashers sold separately. See Figs. 4 & 5 ▲ distributor stocked

Fig. 1

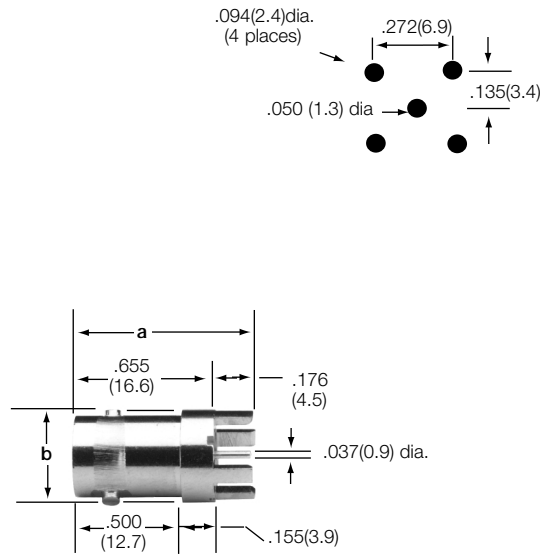

BNC PCB Receptacle (Jack)  
Post Terminal, 4 Legs  
.433" (11.0mm) Dia. Base  
**31-5329-72RFX**

**PRINTED CIRCUIT BOARD RECEPTACLE**

Description	Terminal Type	Dimensions, inches (mm)		Notes		Mtg. Hole	Amphenol Number	Fig.
		a	b	Plt.	Ins.			
PCB Receptacle, Vertical, 4 Legs .176(4.5) Long/ Post terminal .037(0.9)" Dia.	Blunt Post	.831(21.1)	.433(11.0) dia	P17	D25	F	<a href="#">31-5329-72RFX</a>	1 ▲

▲ distributor stocked

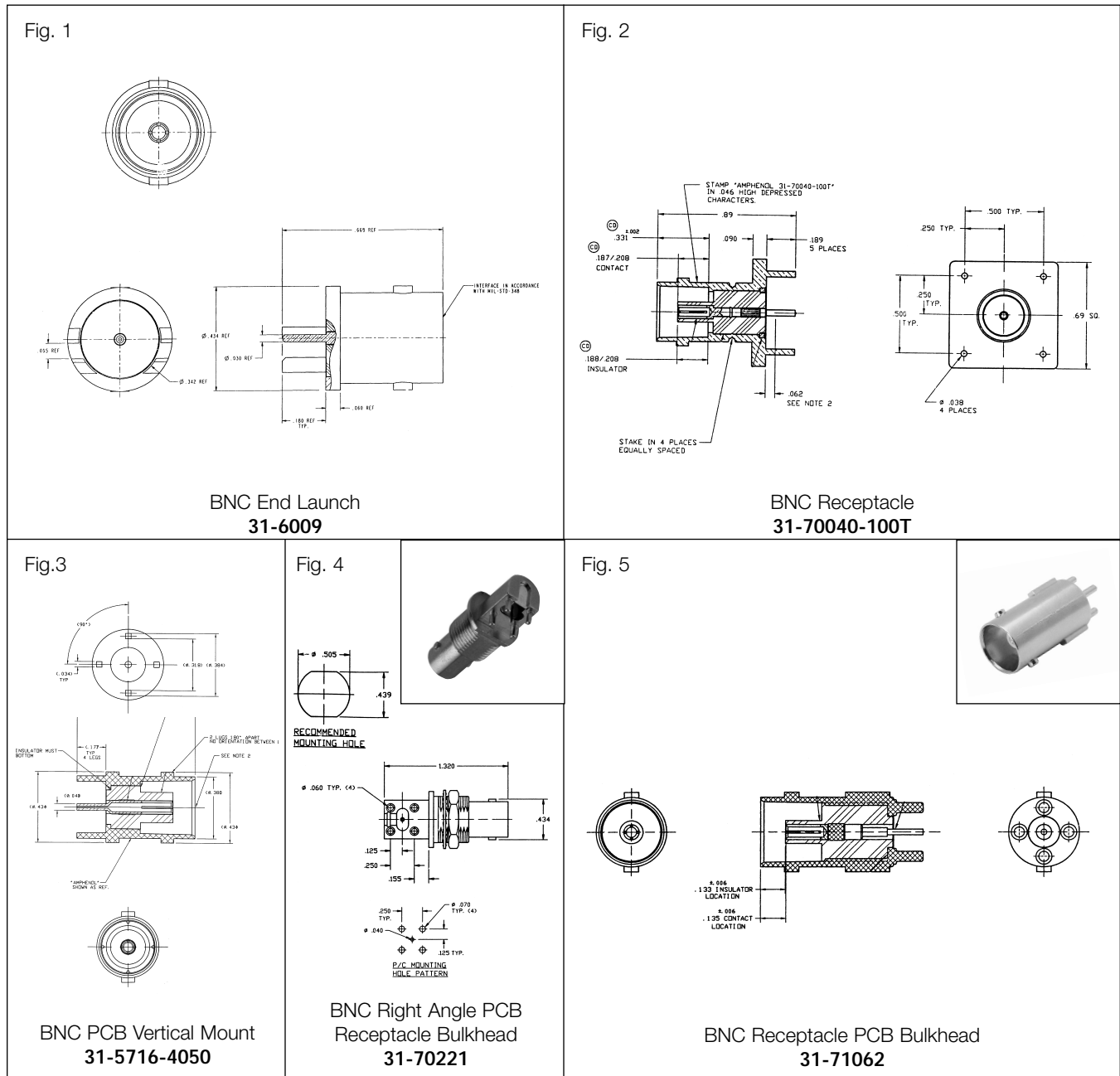

## 75Ω BNC JACKS

Description	Terminal Type	Dimensions, inches (millimeters)			Notes		Mtg. Hole	UG No.	75Ω	Amphenol Number	Fig.
		a	b	c	Plt.	Ins.					
PCB Vertical Mount	Blunt Post	.716(18.2)	.434(11.0)	.177(4.5)	P17	D1	—	—	T2	31-5716-4050	3
End Launch Rec.	Blunt Post	.668(17.0)	.434(11.0)	.060(1.5)	P17	D1	—	—	T1	31-6009	1
Receptacle	Blunt Post	.890(22.6)	.380(9.7)	.189(4.8)	P17	D1	—	—	T1	31-70040-100T	2
Rt. Angle PCB Rec Bulkhead	Blunt Post	1.32(33.5)	.434(11.0)	.158(4.0)	P17	D1	—	—	T1	31-70221	4
Rec. PCB Bulkhead	Blunt Post	.880(22.4)	.380(9.7)	.160(4.1)	P17	D1	—	—	T1	31-71062	5

▲ distributor stocked

# BNC 75 ohm High Performance Beryllium Copper Outer Contacts

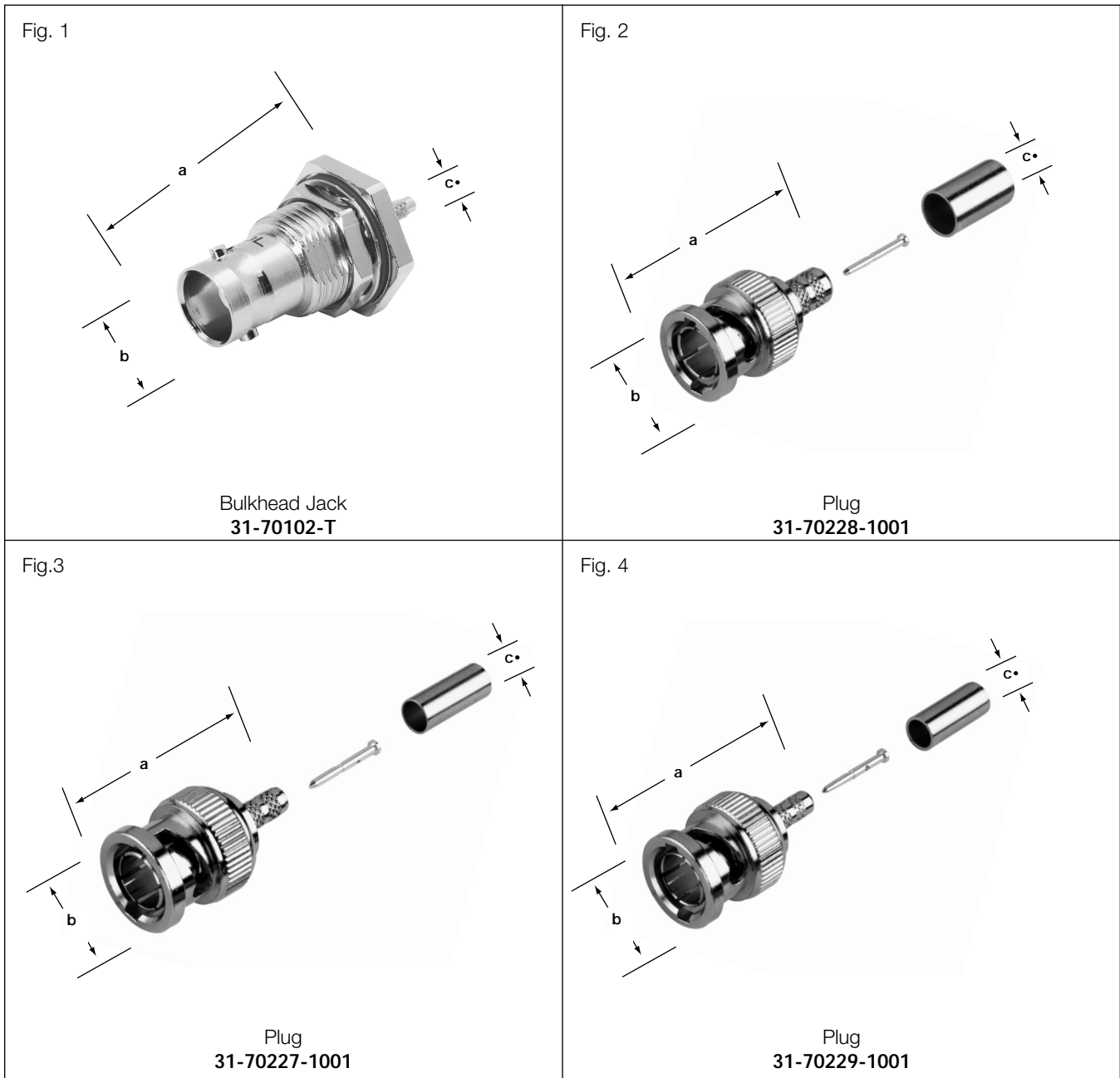

## HIGH PERFORMANCE

Description	Cable	Dimensions, inches (millimeters)			Notes		Mtg. Hole	UG No.	75Ω	Amphenol Number	Fig.
		a	b	c	Plt.	Ins.					
Bulkhead Jack	Rockwell 425-1129-000	1.417	.687	.128	P7	CA	—	—	T1	<a href="#">31-70102-T</a>	1
Plug	734A	1.20	.563	.226	P7	CA	—	—	T1	<a href="#">31-70228-1001</a>	2
Plug	L910	1.20	.563	.106	P7	CA	—	—	T1	<a href="#">31-70227-1001</a>	3
Plug	735A	1.20	.563	.141	P7	CA	—	—	T1	<a href="#">31-70229-1001</a>	4

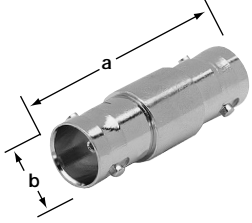
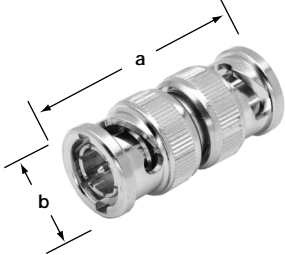
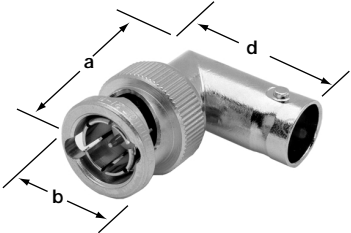
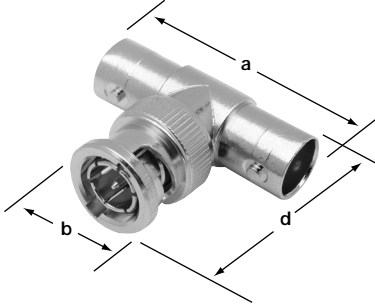
<p>Fig. 1</p>  <p>75Ω BNC Adapter (J/J) <b>31-219-75</b> <b>31-70019</b></p>	<p>Fig. 2</p>  <p>75Ω BNC Adapter (P/P) <b>31-218-75RFX</b></p>
<p>Fig.3</p>  <p>75Ω BNC Adapter (P/J) <b>31-9-75</b> <b>31-9-75-RFX</b></p>	<p>Fig. 4</p>  <p>75Ω BNC Tee Adapter (J/P/J) <b>31-70036</b></p>

BNC

## 75Ω BNC ADAPTERS

Description		Dimensions, inches (millimeters)			Notes		Mtg. Hole	UG No.	75Ω Type	Amphenol Number	Fig.
		a	b	d	Plt.	Ins.					
Straight	Jack-Jack	1.28(32.5)	.434(11.0)	—	P15	D1	—	—	T2	<a href="#">31-219-75</a>	1
Straight	Jack-Jack	1.40(35.6)	.434(11.0)	—	P17	D1	—	—	T1	<a href="#">31-70019</a>	1 ▲
Straight	Plug-Plug	1.33(33.7)	.571(14.5)	—	P15	D1	—	—	T2	<a href="#">31-218-75RFX</a>	2
Angle	Jack-Plug	1.02(25.9)	.562(14.3)	.405(10.3)	P15	D9	—	—	T2	<a href="#">31-9-75</a>	3 ▲
Tee	Jack-Plug-Jack	1.28(32.5)	.562(14.3)	1.04(26.3)	P15	D1	—	—	T1	<a href="#">31-70036</a>	4

▲ distributor stocked

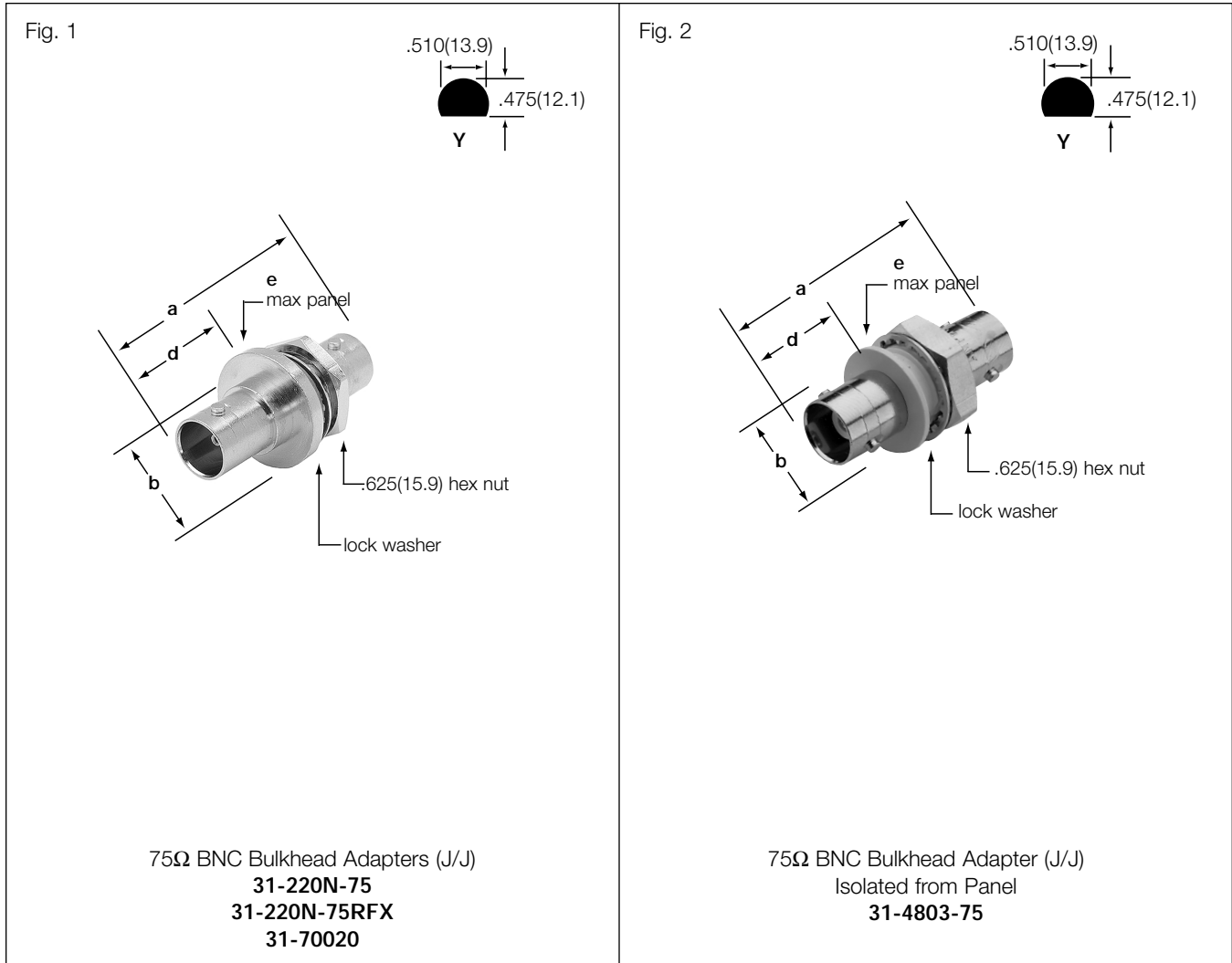

## 75Ω BNC BULKHEAD ADAPTERS

Description		Dimensions, inches (millimeters)				Notes		Mtg. Hole	UG No.	75Ω Type	Amphenol Number	Fig.
		a	b	d	e	Plt.	Ins.					
Gasketed	Jack-Jack	1.40(35.6)	.750(19.0)	.666(16.9)	.172(4.4)	P15	D1	Y	—	T1	<a href="#">31-70020</a>	1
Not Gasketed	Jack-Jack	1.28(32.5)	.750(19.0)	.492(12.5)	.216(5.5)	P7	D23	Y	—	T2	<a href="#">31-220N-75RFX</a>	1 ▲
Not Gasketed	Jack-Jack	1.40(35.6)	.800(20.3)	.664(16.8)	.181(4.6)	P17	D1	Y	—	T2	<a href="#">31-220N-75</a>	1
Isolated	Jack-Jack	1.28(32.5)	.625(15.9)	.460(11.7)	.190(4.8)	P17	D12	Y	—	T2	<a href="#">31-4803-75</a>	2 ▲

▲ distributor stocked

## Данный компонент на территории Российской Федерации

### Вы можете приобрести в компании MosChip.

Для оперативного оформления запроса Вам необходимо перейти по данной ссылке:

<http://moschip.ru/get-element>

Вы можете разместить у нас заказ для любого Вашего проекта, будь то серийное производство или разработка единичного прибора.

В нашем ассортименте представлены ведущие мировые производители активных и пассивных электронных компонентов.

Нашей специализацией является поставка электронной компонентной базы двойного назначения, продукции таких производителей как XILINX, Intel (ex.ALTERA), Vicor, Microchip, Texas Instruments, Analog Devices, Mini-Circuits, Amphenol, Glenair.

Сотрудничество с глобальными дистрибьюторами электронных компонентов, предоставляет возможность заказывать и получать с международных складов практически любой перечень компонентов в оптимальные для Вас сроки.

На всех этапах разработки и производства наши партнеры могут получить квалифицированную поддержку опытных инженеров.

Система менеджмента качества компании отвечает требованиям в соответствии с ГОСТ Р ИСО 9001, ГОСТ РВ 0015-002 и ЭС РД 009

### Офис по работе с юридическими лицами:

105318, г.Москва, ул.Щербаковская д.3, офис 1107, 1118, ДЦ «Щербаковский»

Телефон: +7 495 668-12-70 (многоканальный)

Факс: +7 495 668-12-70 (доб.304)

E-mail: [info@moschip.ru](mailto:info@moschip.ru)

Skype отдела продаж:

moschip.ru

moschip.ru\_4

moschip.ru\_6

moschip.ru\_9