

# D-SUBMINIATURE CONNECTORS

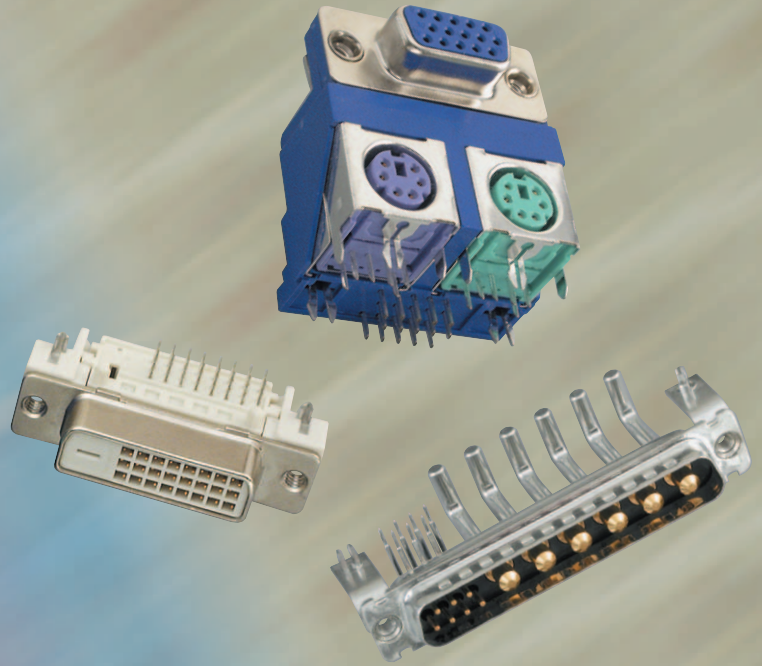

# Amphenol®

ACCESSORIES

STANDARD DENSITY

SURFACE MOUNT RECEPTACLES

HIGH DENSITY

## Table of Contents

DESCRIPTION	SERIES	PAGES
General Specifications .....		1
 <b>HIGH DENSITY D-SUBS</b>		
Right Angle Board Mount Connectors .....	17BH.....	2
Solder Cup and Straight Board Mount Connectors .....	17HD .....	2
Digital Video Interface (DVI) <b>NEW</b> .....	G12 .....	52
 <b>SURFACE MOUNT RECEPTACLES</b>		
Right Angle Connector, Front Metal Shell, Socket only .....	17SM2 .....	5
 <b>STANDARD DENSITY D-SUBS - BOARD MOUNT</b>		
Fixed Precision-Formed Contact Connectors .....	617 .....	8
.....	17SD.....	16
Dual Port Stacked Right Angle Connectors, Front Metal Shell.....	617H.....	10
High-Temperature Right Angle Connectors, Front Metal Shell.....	17HTN .....	12
High-Temperature Vertical Connectors, Front Metal Shell .....	617S.....	14
Fixed Machined Contact Industrial Connectors .....	17D / DF .....	20
Combination (Hybrid) Connectors .....	17TW .....	37
Filtered D-Sub Connector, Stacked .....	FCC17 .....	55
Filtered D-Sub Connector, Press Fit <b>NEW</b> .....	FCC17 .....	55
Filtered D-Sub Connector and Filtered Combo .....	FCC17 .....	56
Sealed D-Sub Connector <b>NEW</b> .....	SD308 .....	53
Filtered D-Sub Connector, Ruggedized <b>NEW</b> .....	FD308 .....	54
 <b>STANDARD DENSITY D-SUBS - CABLE MOUNT</b>		
Fixed Precision-Formed Contact Connectors.....	17SD.....	16
Fixed Machined Contact Industrial Connectors .....	17D / DF .....	20
Fixed Machined Contact Industrial Connectors, Screw Termination <b>NEW</b> .....	17D-ST .....	26
Rear Release Crimp Connectors.....	17RR.....	29
Tooling for Crimp Contacts .....	RR-HR .....	36
Combination (Hybrid) Connectors .....	17TW .....	37
Removable Contacts (Size 8 Coax and Power) for Hybrid Connectors .....	17DM .....	45
Tooling for Size 8 Coax Contacts .....		47
Filtered D-Sub Connector and Filtered Combo .....	FCC17 .....	56
Filtered D-Sub Connector, IDC <b>NEW</b> .....	FCC17 .....	55
 <b>ACCESSORIES</b>		
Backshells .....		57
 <b>GENERAL INFORMATION</b>		
Panel Cutouts and Mounting.....		IBC

#### GENERAL DESCRIPTION:

---

Amphenol's line of D-Subminiature rack and panel connectors is part of an industry standard for applications requiring reliable, rugged, connectors. These connectors are designed to accommodate rack and panel, cable to panel and cable to cable applications. D-Subminiature connectors are pin and socket devices that employ contacts encased in a molded dielectric insert surrounded by a "D" shaped shell for polarization.

#### MARKETS:

---

Amphenol D-Subminiature connectors can be used in commercial, industrial or military markets. We offer a broad selection of dielectric materials and contact styles and configurations to meet all of your design requirements.

#### APPLICATIONS INCLUDE:

---

- Business equipment
- Electronic office systems
- Data communications
- Medical equipment
- Mobile communications
- Consumer electronics

#### AMPHENOL D-SUB FEATURES:

---

- Industry standard interfacing RS232 and RS449 mating configurations per EIA standards.
- UL Component Recognition File number E64911 (617, 841, 17, 17D, 17HD, ED, 17RR, 17SD, 117DF, 17BH, 17TW)
- Variations available:
  - Solder cup
  - Straight pc mount solder
  - Right angle pc mount solder
  - Solderless wire wrap
  - Crimp
  - High Density Right Angle
  - High Density Straight
  - Stacked Right Angle PC mount
  - Surface mount
- Five shell sizes offer widest choice of contact positions: 9, 15, 25, 37 and 50 in standard density and 15, 26, 44, 62 and 78 positions in high-density.
- Inserts are flame-retardant thermoplastic.
- Accessories for all applications are available including strain reliefs, cable clamps, shielded backshells, mating hardware and connector to pc board mounting hardware.
- Automatic and manual tooling is available for both crimp and IDC versions.
- Contact Amphenol for lease information.

High Density

**SPECIFICATIONS:**

**MATERIALS AND PLATINGS**

<b>Shells</b>	Steel, tin plated, grounding indents on plug.
<b>Contact Material</b>	Copper alloy
<b>Contact Plating</b>	Engagement area: gold (see ordering information).
<b>Termination End</b>	150µ" (3.81µm) tin/lead
<b>Nickel Underplate</b>	50µ" (1.27µm) entire contact

**ELECTRICAL DATA**

<b>Current Rating</b>	3 Amps maximum per contact
<b>Voltage Rating</b>	125 VAC
<b>Dielectric Withstanding Voltage</b>	1000 VAC (minimum)
<b>Dielectric</b>	Glass filled thermoplastic, black, UL 94 VO
<b>Insulation Resistance</b>	5,000 Megaohms (minimum)
<b>Contact Resistance</b>	15 Milliohms (maximum)

**CLIMATIC DATA**

<b>Operating Temperature</b>	-67°F (-55°C) to 221°F (105°C)
------------------------------	--------------------------------

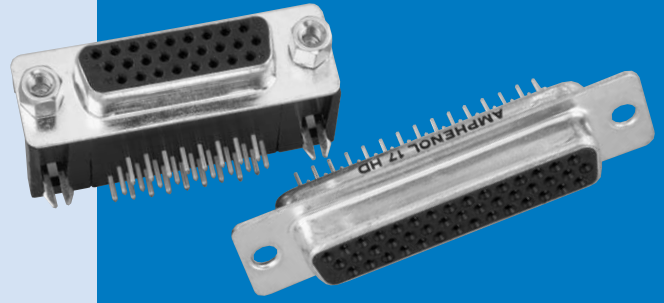

17 BH/HD SERIES

Amphenol's High Density D-Subminiature connectors complement Amphenol's extensive D-Subminiature connector line. This line of connectors offers many superior features, high performance level and low installation cost.

The connector configurations are available in 15, 26, 44, 62 and 78 positions.

The product offering includes PCB mount connectors in both straight or right angle termination styles. Straight PCB mount are available in both Fixed Screw Machine and Stamped and Formed contacts, while Right Angle PCB mount are only available with Stamped and Formed contacts.

A cable mount version with solder terminations is also available, which can be combined with Amphenol's standard line of shielded or unshielded backshells.

- Industrial
- Telecom
- Any industry standard I / O connections

INCHES (MM)



DIMENSIONS FOR 15 - 62 POSITION (3 ROW)(SHOWN WITH FIXED FEMALE SCREWLOCKS) DIMENSIONS FOR THE 78 POSITION (4 ROW)

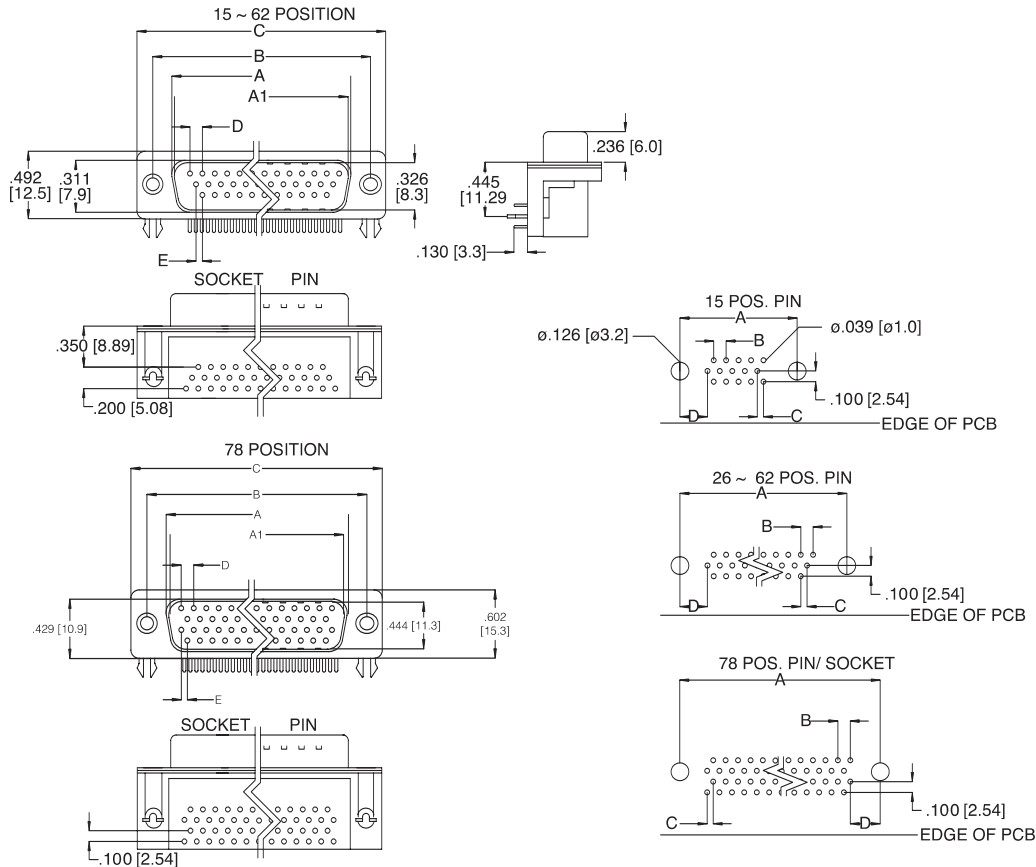

CONTACTS	A SOCKET	A1 PIN	B	C	D	E
15	.642 [16.30]	.666 [16.92]	.984 [25.0]	1.213 [30.8]	.090 [2.29]	.045 [1.145]
26	.969 [24.6]	.994 [25.25]	1.311 [33.3]	1.543 [39.2]	.090 [2.29]	.045 [1.145]
44	1.508 [38.3]	1.534 [38.96]	1.854 [47.1]	2.091 [53.1]	.090 [2.29]	.045 [1.145]
62	2.157 [54.8]	2.182 [55.42]	2.50 [63.5]	2.732 [69.4]	.095 [2.41]	.047 [1.205]
78	2.05 [52.20]	2.079 [52.81]	2.40 [61.0]	2.638 [67.0]	.095 [2.41]	.047 [1.205]

CONTACTS	A	B	C	D
15	.984 [25.0]	.090 [2.29]	.045 [1.145]	.277 [7.04]
26	1.311 [33.3]	.090 [2.29]	.045 [1.145]	.271 [6.88]
44	1.854 [47.1]	.090 [2.29]	.045 [1.145]	.271 [6.88]
62	2.50 [63.5]	.095 [2.41]	.047 [1.205]	.275 [7.00]
78	2.402 [61.0]	.095 [2.41]	.047 [1.205]	.300 [7.63]

### ORDERING INFORMATION

## 17BH Series High Density D-Sub

Front Metal Shell, Right-Angle PC Mount

### 17BH - 0XX - X - XX - X - XX

**Series** \_\_\_\_\_

**Number Of Positions** \_\_\_\_\_  
15, 26, 44, 62, 78

**Type** \_\_\_\_\_

**P** Pin (male)  
**S** Socket (female)

**PCB Mount Options**

**00** Clear hole  
**10** Arrowhead Board

**Panel Mounting Options**

**0** .120 (3.05) Clear Hole  
**1** #4-40 Threaded Hole  
**2** #4-40 Fixed Female Screw

**Plating Code**

**AA** Gold Flash over Nickel  
**AM** 30µ\* (.76µm) Gold over Nickel



**DIMENSIONS**

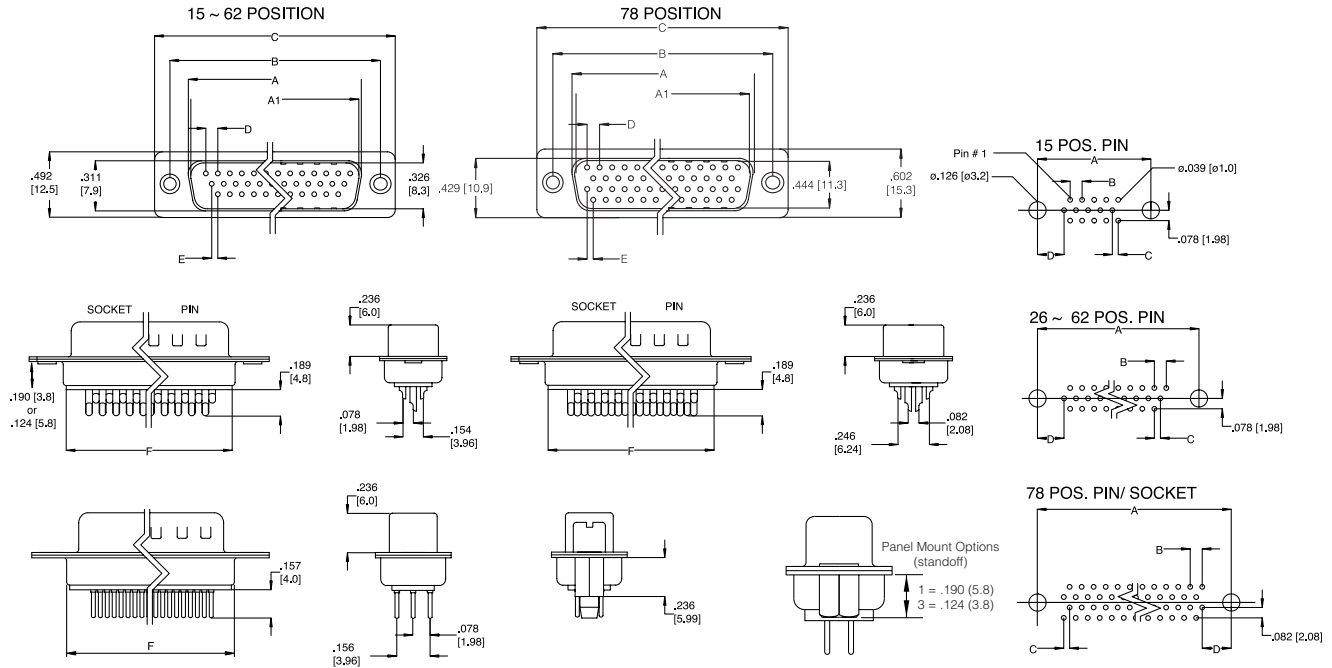

CONTACTS	A SOCKET	A1 PIN	B	C	D	E	F
15	.642 [16.30]	.666 [16.92]	.984 [25.0]	1.213 [30.8]	.090 [2.29]	.045 [1.145]	.756 [19.2]
26	.969 [24.6]	.994 [25.25]	1.311 [33.3]	1.543 [39.2]	.090 [2.29]	.045 [1.145]	1.071 [27.2]
44	1.508 [38.3]	1.534 [38.96]	1.854 [47.1]	2.091 [53.1]	.090 [2.29]	.045 [1.145]	1.618 [41.1]
62	2.157 [54.8]	2.182 [55.42]	2.50 [63.5]	2.732 [69.4]	.095 [2.41]	.047 [1.205]	2.256 [57.3]
78	2.05 [52.20]	2.079 [52.81]	2.40 [61.0]	2.638 [67.0]	.095 [2.41]	.047 [1.205]	2.169 [55.1]

CONTACTS	A	B	C	D
15	.984 [25.0]	.090 [2.29]	.045 [1.145]	.277 [7.04]
26	1.311 [33.3]	.090 [2.29]	.045 [1.145]	.277 [7.04]
44	1.854 [47.1]	.090 [2.29]	.045 [1.145]	.277 [7.04]
62	2.50 [63.5]	.095 [2.41]	.047 [0.120]	0.699
78	2.402 [61.0]	.095 [2.41]	.047 [0.120]	0.699

**ORDERING INFORMATION**

**17 HD Series High Density D-Sub**

*Solder Cup & Straight P.C. Mount, Front Metal Shell Fixed Contact*

**17HD - 0XX - X - XX - X - XX**

Series \_\_\_\_\_

Number Of Positions  
15, 26, 44, 62, 78

Type  
P Pin (male)  
S Socket (female)

**Termination Types:**

- 00 Solder Cup
- 30 Board-mount, Vertical
- 32 Board-mount, Vertical with Boardlocks
- 33 Board-mount, Vertical with standoff, no boardlock

**Panel Mounting Options:**

- 0 .120 (3.05) Clear Hole
- 1 #4-40 Threaded Hole .190 (5.8)
- 2 #4-40 Fixed Female Screwlock
- 3 #4-40 Threaded Hole .124 (3.8)

**Plating Code:**

- AA Gold Flash over Nickel
- AM 30µ" (.76µm) Gold over Nickel

INCHES (MM)

## SM2 SERIES

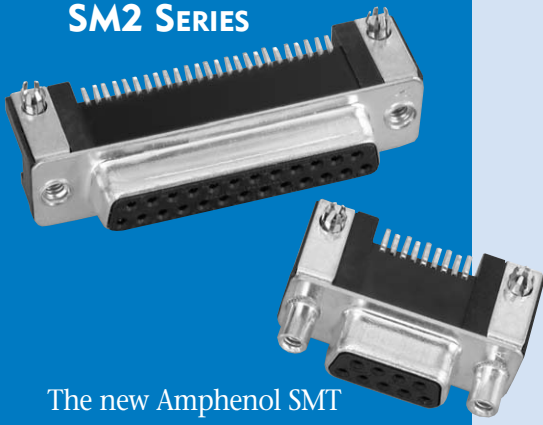

The new Amphenol SMT D-Sub is offered in right angle, receptacle with brackets, as an industry standard for I / O connections.

New boardlock features:  
 -LIF (Low Insertion Force) boardlock especially designed to be fully compatible with pick and place equipment.  
 -ZeFo (Zero Insertion Force) boardlock has been designed so that once placed and expanded, secures the connector in place.

### Applications

- Industrial
- Telecom
- Any industry standard I / O connections

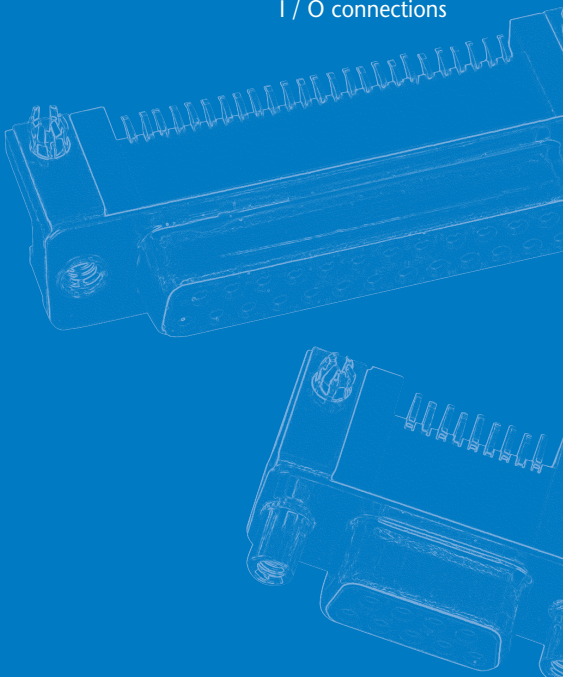

## Stamped And Formed Contacts Surface Mount Connectors

### SPECIFICATIONS:

#### MATERIALS AND PLATINGS

<b>Shells</b>	Steel with tin plating
<b>Insulator</b>	High temperature (peak at 500°F [260°C]) glass-filled thermoplastic, UL 94V-0
<b>Socket Contact</b>	Stamped and formed brass, selected gold in mating area; 100μ" (2.54μm) min. tin-lead on termination area, with entire contact under-plated 50μ" (1.27μm) min. nickel
<b>Rear Insert</b>	Brass, 118μ" up to 197μ" (3μm up to 5μm) tinned over nickel 78μ" to 118μ" (2μm up to 3μm)
<b>Boardlock</b>	Tin-lead plating 157μ" up to 236μ" (4μm up to 6μm) over nickel 78μ" up to 118μ" (2μm up to 3μm) Insertion force: Low Insertion Force = LIF (bronze) Zero Insertion Force = ZeFo (brass)
<b>Screwlock</b>	Brass, 236μ" up to 394μ" (6μm up to 10μm) tinned over nickel 78μ" up to 118μ" (2μm up to 3μm)
<b>Grounding</b>	Grounding strap: brass, (4μ" up to 6μ") (0.10μm up to 0.15μm) tin-lead plating over nickel 78μ" up to 118μ" (2μm up to 3μm)

#### ELECTRICAL DATA

<b>Current Rating</b>	3A
<b>Voltage Rating</b>	300V AC/ rms 50Hz
<b>Withstanding Voltage</b>	1000V AC/ rms 50Hz for one minute
<b>Insulation Resistance</b>	5000MΩ
<b>Contact Resistance</b>	10 mΩ max.

#### CLIMATIC DATA

<b>Operating Temperature</b>	185°F (85°C), peak at 221°F (105°C)
<b>Damp Heat</b>	56 days 221°F (105°C) - 95% RH

#### MECHANICAL DATA

<b>Single Contact Insertion Force</b>	1.2N < F < 2.5N
<b>Single Contact Withdrawal Force</b>	0.4N min.
<b>LIF Boardlock</b>	8N max. per connector
<b>Coplanarity of Contacts</b>	.008" (0.2) max.

**Mating and Unmating Force**  
Unit: N

No. of Contacts	Mate (max.)	Unmate (min.)
9 (size E)	30	3.5
15 (size A)	50	4.5
25 (size B)	83	8.0

SHELL DIMENSIONS

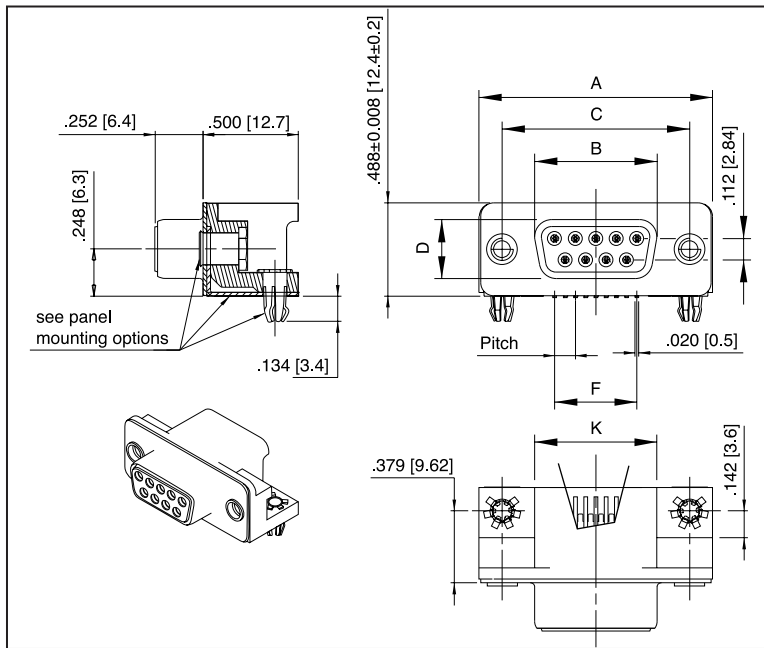

PCB LAYOUT

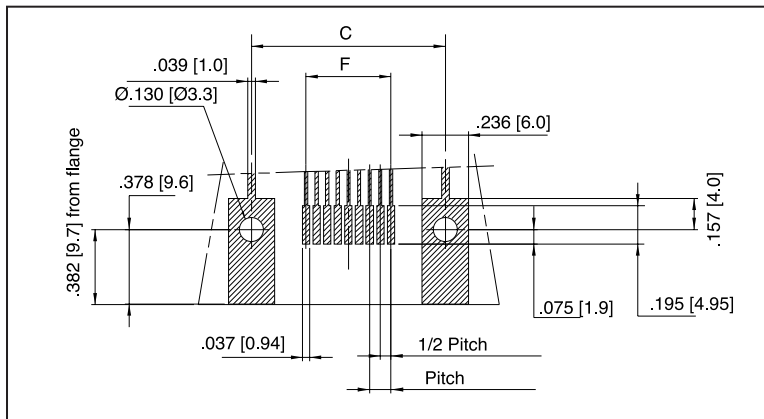

GROUNDING TABS

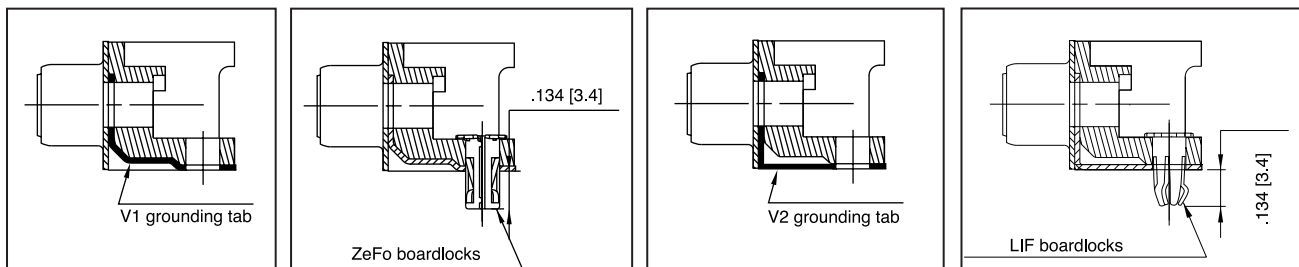

SHELL SIZE	A	B	C	D	PITCH	F	K
	+ .002 (0.05) - .004 (0.1)	0 - .008 (0.2)	± .004 (0.1)	0 - .01 (0.25)			
E	1.226 (31.15)	.645 (16.4)	.984 (25)	.316 (8.03)	.1078 (2.74)	.432 (10.97)	.642 (16.3)
A	1.551 (39.4)	.976 (24.8)	1.311 (33.3)	.316 (8.03)	.1078 (2.74)	.756 (19.2)	.968 (24.6)
B	2.098 (53.3)	1.515 (38.5)	1.850 (47)	.316 (8.03)	.1086 (2.76)	1.304 (33.12)	1.508 (38.3)

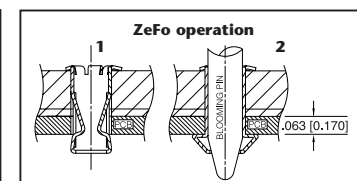

Blooming Pin Tool  
P.N. 356-500

INCHES (MM)



FLANGE ACCESSORIES

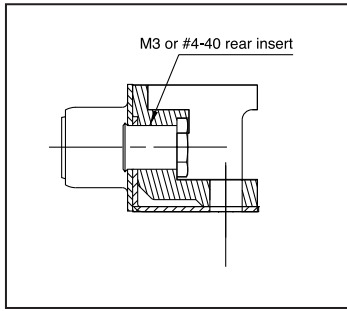

Threaded Rear  
1/2

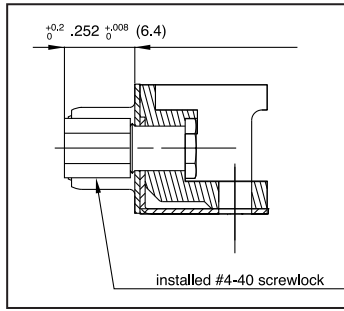

Installed Front Female  
5

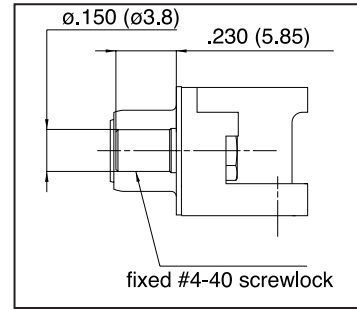

Fixed Front Female  
6

ORDERING INFORMATION

17SM2 - XX - S - X - X - X - X

Configuration :

- 09
- 15
- 25

**SOCKET ONLY**

Board locks / grounding tab:

- 1 V1 grounding tab +ZeFo boardlocks (PCB = .062 [1.6])
- 4 ZeFo boardlocks only (PCB = .062 [1.6])
- 7 V1 grounding tab only
- 8 no grounding tab and no boardlocks
- B V2 grounding tab + LIF boardlocks (PCB = .062 [1.6])

Packaging:

- R reel (9 Pos only, 100/reel)
- T tube

Contact plating:

- 1 7.9µ" (0.2µm Au)
- 2 15.7µ" (0.4µm Au)
- 3 19.7µ" (0.5µm Au)
- 4 31.5µ" (0.8µm Au)
- 6 50µ" (1.27µm Au)

Mounting options:

- 1 rear insert 4-40
- 2 rear insert M3
- 5 installed front screwlock 4-40
- 6 fixed front screwlock 4-40

■ : Standard options

**Right-Angle Board Mount Connectors  
Front Metal Shell**

**617 SERIES**

**SPECIFICATIONS:**

**MATERIALS AND PLATINGS**

Shells	Steel, tin plated
Contacts	Precision formed copper alloy
Contact Plating	Gold over nickel
Contact Forces	Engagement: 12 oz. max. (340.2 g) Separation: .75 oz. min. (21.26 g)

**ELECTRICAL DATA**

Current Rating	5 amps
Dielectric Withstanding Voltage	1000 VAC/60 sec.
Dielectric	Glass filled thermoplastic, black, UL 94 VO
Contact Resistance	15 milliohms max.

**CLIMATIC DATA**

Temperature Range	-67°F (-55°C) to 221°F (105°C)
-------------------	--------------------------------

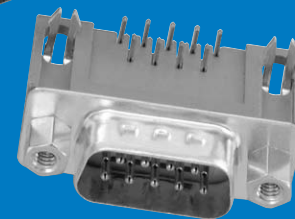
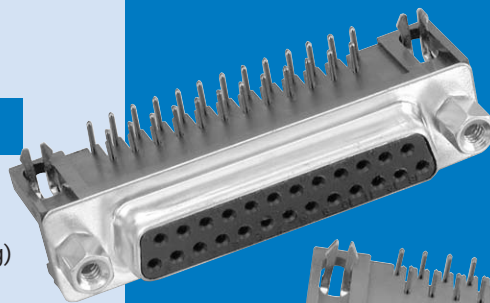

Amphenol's 617 series of right angle commercial connectors provide high performance at competitive prices.

The front metal shell helps to provide reduced EMI/ RFI emissions, and the contacts are selectively plated to provide additional high performance. The 617 series are available in a variety of board mounting and grounding options including arrowhead boardlocks and #4-40 threaded inserts.

Front mounting holes are also available threaded, un-threaded and with installed female hex screwlocks.

- Industrial
- Telecom
- Any industry standard I / O connections

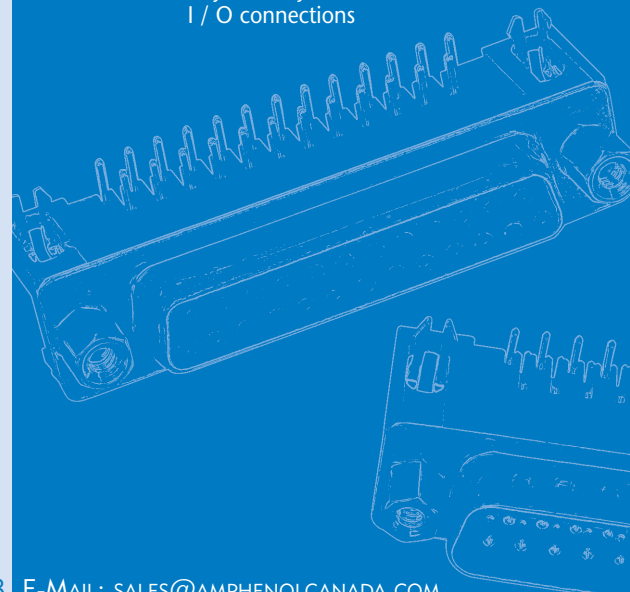

INCHES (MM)

DIMENSIONS

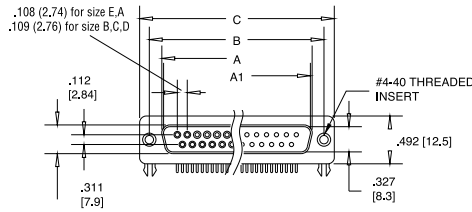

CONTACTS	A SOCKET	A1 PIN	B	C
9	.642 [16,30]	.666 [16,92]	.984 [25,0]	1.213 [30,8]
15	.969 [24,6]	.994 [25,25]	1.311 [33,3]	1.543 [39,2]
25	1.508 [38,3]	1.534 [38,96]	1.854 [47,1]	2.091 [53,1]
37	2.157 [54,8]	2.182 [55,42]	2.50 [63,5]	2.732 [69,4]

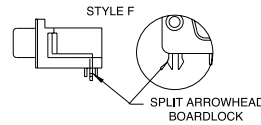
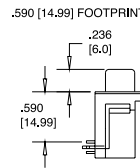
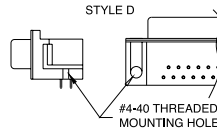
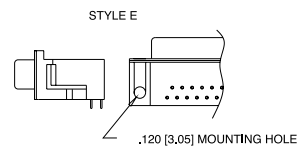
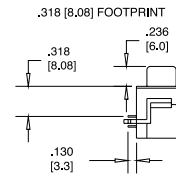
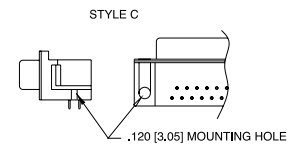
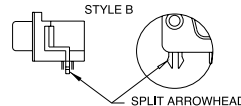
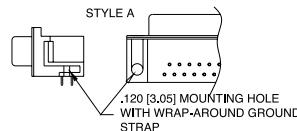
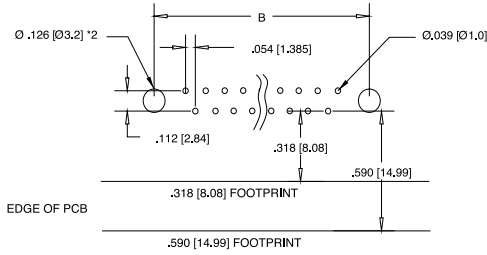
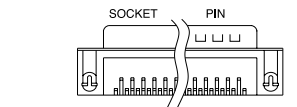

ORDERING INFORMATION

617 - X - 0XX - X - XX - X - XX - X

Series

Number of Contacts  
09, 15, 25, 37

Variation Code

E for U & Y Footprint

Contact

- 20
- 21

Housing Characteristics

- Tin plated receptacle
- Tin plated plug with grounding indents

Code

- 0
- 1
- 2
- 4

Panel Mounting Options

- .120 (3.05) clear hole
- #4-40 threaded hole
- #4-40 threaded hole with female screwlock
- Fixed female round screwlock

.318 (8,08) Footprint	.590 (14,99) Footprint	Description of PC Board Mounting Characteristics	Style
A		.120 (3.05) diameter mtg hole with wrap-around ground strap	A
C		split arrowhead boardlock	B
D	U	.120 (3.05) diameter mtg hole	C&E
J		#4-40 threaded mtg hole	D
	Y	split arrowhead boardlock	F

Code

- P
- S

Contact Type

- Pin (male)
- Socket (female)

Code

- BF

Contact Plating

- Engagement area 3µ" (.076µm) gold flash, terminal end area 100µ"/200µ" (2.54µm/5.08µm) tin/lead underplate of 50µ" (1.27µm) nickel
- CF
- Engagement area 15µ" (.381µm) gold flash, terminal end area 100µ"/200µ" (2.54µm/5.08µm) tin/lead underplate of 50µ" (1.27µm) nickel
- AJ
- Engagement area 30µ" (.76µm) gold, terminal end area 100µ"/200µ" (2.54µm/5.08µm) tin/lead underplate of 50µ" (1.27µm) nickel

For filtered version, see page 56.

Dual Port Connectors

SPECIFICATIONS:

MATERIALS AND PLATINGS

Shells	Steel, tin plated
Contacts	Precision formed copper alloy
Contact Plating	Gold over nickel
Contact Forces	Engagement: 12 oz. max. (340.2 g) Separation: .75 oz. min. (21.26 g)

ELECTRICAL DATA

Current Rating	5 amps
Dielectric Withstanding Voltage	1000 VAC/60 sec.
Dielectric	Glass filled thermoplastic, black, UL 94 VO
Contact Resistance	15 milliohms max.

CLIMATIC DATA

Temperature Range	-67°F (-55°C) to 221°F (105°C)
-------------------	--------------------------------

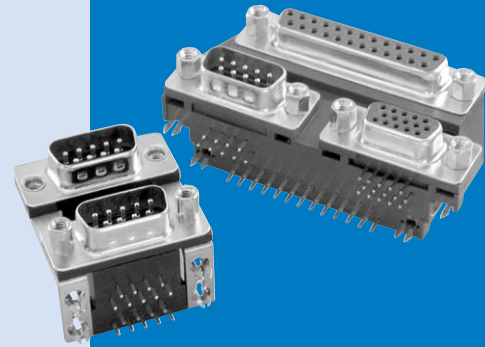

617 H SERIES

Amphenol's 617 series dual port connectors are a state of the art design. The front metal shell helps reduce EMI/RFI emissions.

Contacts are selectively plated for high performance at a low cost.

Designed to save PC board space, Amphenol's dual port "D" provides two input output connectors in a minimal amount of board space.

These connectors are available with various stacking options: same gender, mixed gender and multiple pin counts.

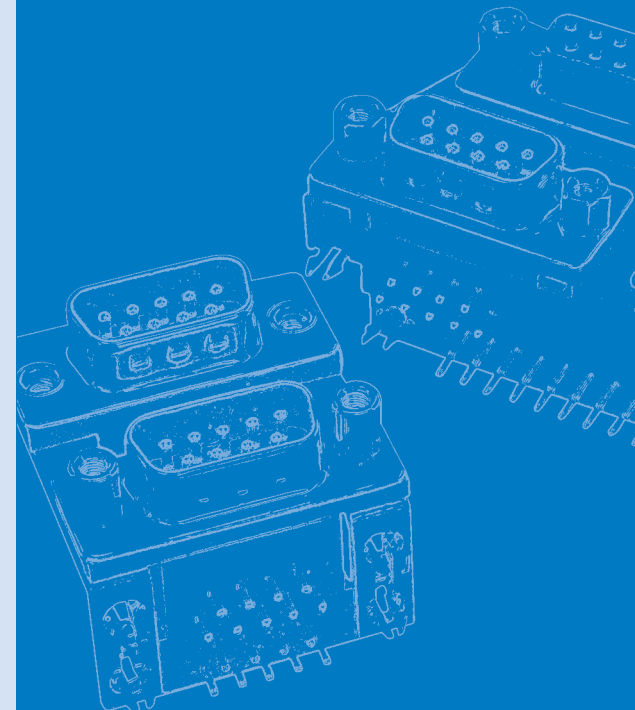

INCHES (MM)

**DIMENSIONS**

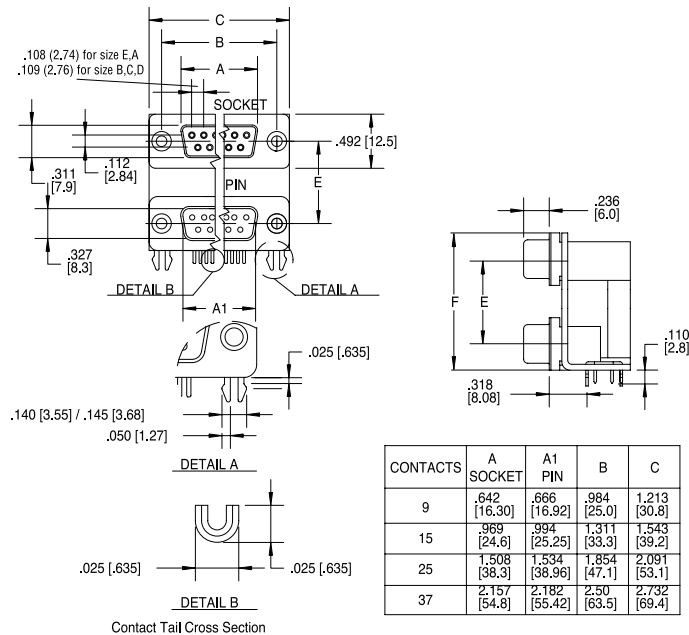

Code Letter	Product Description		Dimensions	
	Top Connector	Bottom Connector	E	F
A	Pin	Pin	0.900 ± 0.010 (22.86 ± 0.25)	1.415 (35.94)
B	Socket	Socket		
C	Pin	Socket		
D	Socket	Pin		
E	Pin	Pin	0.750 ± 0.010 (19.05 ± 0.25)	1.265 (32.13)
F	Socket	Socket		
G	Pin	Socket		
H	Socket	Pin	0.625 ± 0.010 (15.88 ± 0.25)	1.140 (28.96)
J	Pin	Pin		
K	Socket	Socket		
L	Pin	Socket		
M	Socket	Pin		

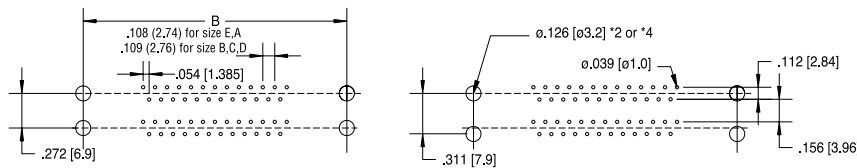

PCB EDGE

**ORDERING INFORMATION**

**617H - X - XX - X - XX - X - XX - X**

**Series**  
617H Dual port;  
right angle solder tail

**Code Boardlock**  
C Boardlock option  
O No PC boardlock

**Code Number of Contacts**

18	2 x 9	15	15 over blank
30	2 x 15	34	9 / 25
50	2 x 25	43	25 / 9+9
74	2 x 37	H15A	VGA / Triple Audio
40	15 / 25		

Consult factory for other available configurations

**Variation Code**  
L for .311 (7.89) Footprint

**Code Housing Characteristics**

- 00 Steel shell, tin plated receptacles without grounding dimples (options B, F, K)
- 01 Steel shells, tin plated plugs with grounding dimples (options A, E, J)
- 03 Steel shells, tin plated, plug shell with grounding dimples and receptacle shell without dimples (options C,G,L,D,H,M)

**Code Panel Mounting Options**

- 0 120° clear hole
- 1 #4-40 threaded hole
- 2 #4-40 threaded hole with female screwlock

**Code Contact Plating**

- BF Engagement area 3µ (.076µm) gold flash, terminal end area 100µ/200µ tin/lead, (2.54µm/5.08µm) tin/lead underplate of 50µ (1.27µm) nickel
- CF Engagement area 15µ (.381µm) gold flash, terminal end area 100µ/200µ (2.54µm/5.08µm) tin/lead underplate of 50µ (1.27µm) nickel
- AJ Engagement area 30µ (.76µm) gold, terminal end area 100µ/200µ (2.54µm/5.08µm) tin/lead underplate of 50µ (1.27µm) nickel

58.064 (22.86) Spacing	48.388 (19.05) Spacing	40.31 (15.87) Spacing	Product Description	
			Top Connector	Bottom Connector
A	E	J	Pin	Pin
B	F	K	Socket	Socket
C	G	L	Pin	Socket
D	H	M	Socket	Pin

For filtered version, see page 55.



**High Temperature Right Angle,  
Board Mount Connectors Front Metal Shell**

**SPECIFICATIONS:**

**MATERIALS AND PLATINGS**

Shells	Steel/nickel plated
Contacts	Precision formed copper alloy
Contact Plating	Gold over nickel
Process Compatibility	IR - air convection: 500° F (260°) for 20 seconds

**ELECTRICAL DATA**

Current Rating	5 amps
Voltage Rating	600 V
Dielectric	Glass filled thermoplastic, black, UL 94 VO
Contact Resistance	10 milliohms (max.)

**CLIMATIC DATA**

Temperature Range	Environmental: -67°F (-55°C) to 257°F (125°C)
-------------------	--

**17 HTN SERIES**

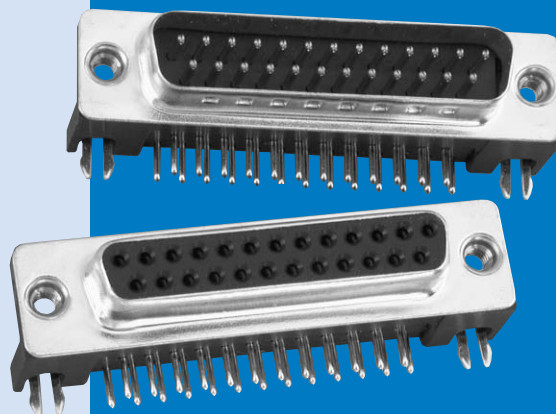

Amphenol's high temperature series meets the market demand for connectors that can withstand the high temperature soldering process. These connectors are compatible with surface-mount, infrared reflow soldering process.

17HTN Series right-angle connectors are available in 9, 15, 25 and 37 positions.

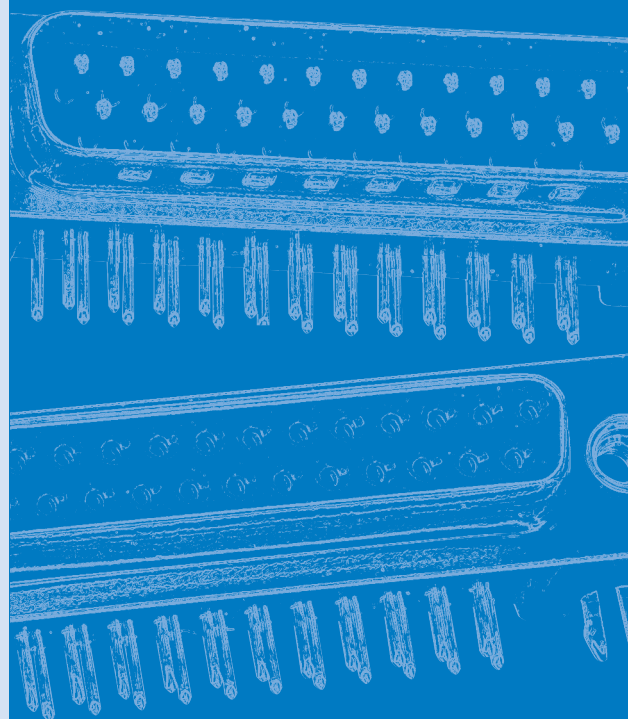

INCHES (MM)

DIMENSIONS

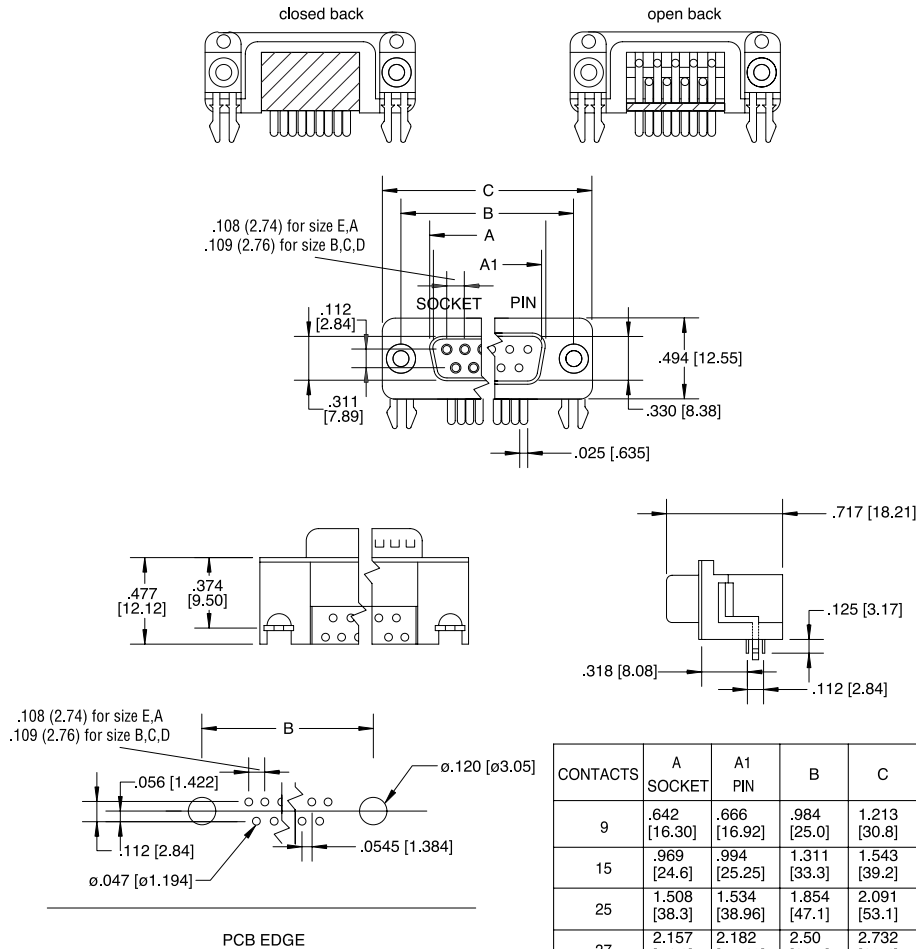

ORDERING INFORMATION

17HTN - X - X - XX - X - C - X

- Series** \_\_\_\_\_
- Code**    **Number of contacts** \_\_\_\_\_
- E     9
- A     15
- B     25
- C     37
- Code**    **Contact** \_\_\_\_\_
- P     Pin (male)
- S     Socket
- Code**    **Panel Mounting Options** \_\_\_\_\_
- 4R    #4-40 Threaded hole
- 4F    #4-40 Female screwlocks

- Code**    **Back Configuration**
- Blank    Closed back
- O        Open back
- Code**    **Packaging**
- C        Cartons
- Code**    **Contact Plating**
- 0        3µ" (.07µm) flash gold  
terminal end area 100µ"/200µ" (2.54µm/5.08µm)  
-tin/lead, underplate of 50µ" (1.27µm) nickel
- 1        Engagement area 10µ" (.25µm) gold,  
terminal end area 100µ"/200µ" (2.54µm/5.08µm)  
-tin/lead, underplate of 50µ" (1.27µm) nickel
- 2        Engagement area 30µ" (.76µm) gold,  
terminal end area 100µ"/200µ" (2.54µm/5.08µm)  
-tin/lead, underplate of 50µ" (1.27µm) nickel
- 3        15µ" (.38µm)  
terminal end area 100µ"/200µ" (2.54µm/5.08µm)  
-tin/lead, underplate of 50µ" (1.27µm) nickel

**High Temperature  
Straight Board Mount Connectors**

**SPECIFICATIONS:**

**MATERIALS AND PLATINGS**

Shells	Steel/nickel plated
Contacts	Precision formed copper alloy
Contact Plating	Gold over nickel

**ELECTRICAL DATA**

Current Rating	5 amps
Voltage Rating	600 V
Dielectric	Glass filled thermoplastic, black, UL 94 VO
Contact Resistance	10 milliohms (max.)

**CLIMATIC DATA**

Temperature Range	Environmental: -67°F (-55°C) to 302°F (150°C)
Process Compatibility	IR-Air Convection 500°F (260°C) for 20 seconds

**617S SERIES**

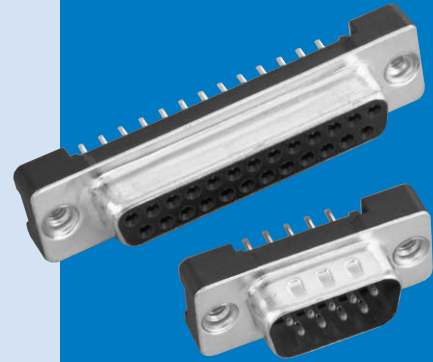

Amphenol's high temperature, low profile D-Sub connector gives you a high quality, reliable commercial connector to meet today's market demands.

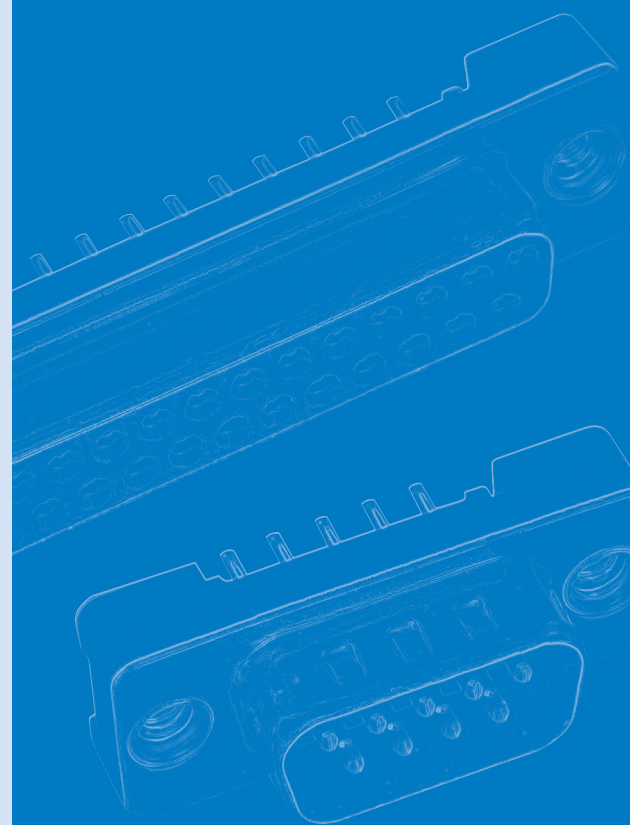

INCHES (MM)

**DIMENSIONS**

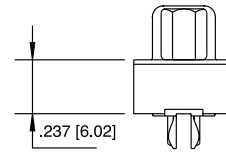
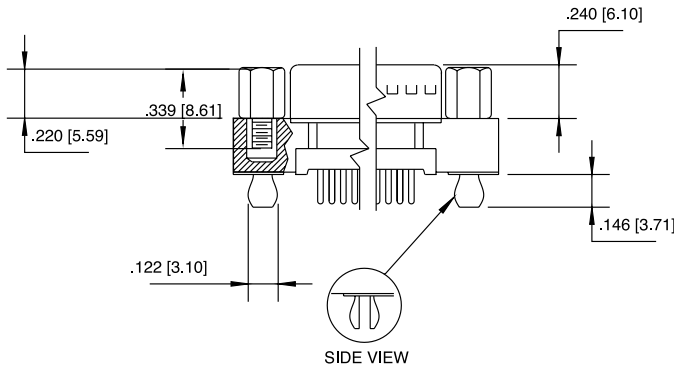
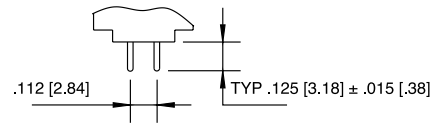
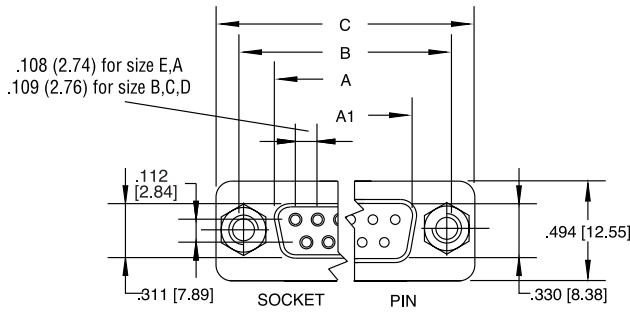

CONTACTS	A SOCKET	A1 PIN	B	C
9	.642 [16.30]	.666 [16.92]	.984 [25.0]	1.213 [30.8]
15	.969 [24.6]	.994 [25.25]	1.311 [33.3]	1.543 [39.2]
25	1.508 [38.3]	1.534 [38.96]	1.854 [47.1]	2.091 [53.1]
37	2.157 [54.8]	2.182 [55.42]	2.50 [63.5]	2.732 [69.4]

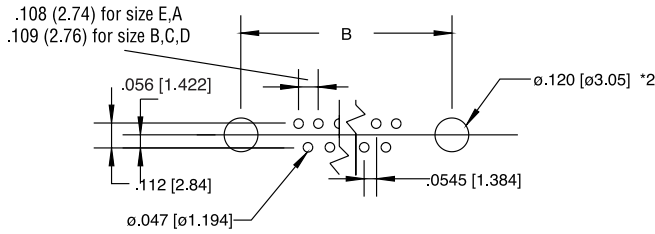

**ORDERING INFORMATION**

**617S - C - 0XX - X - XX - X - XX**

<p><b>Series</b> _____</p> <p><b>Code Boardlock</b> _____</p> <p>C Split arrowhead boardlock O No boardlock</p> <p><b>Number of contacts</b> _____</p> <p>9, 15, 25 or 37</p> <p><b>Code Gender</b> _____</p> <p>P Pin (male) S Socket (female)</p> <p><b>Code Contact Plating</b> _____</p> <p>BJ Engagement area 10µ" (2.54µ), terminal end area 100µ"/200µ" (2.54µ/5.08µ) -tin/lead, underplate of 50µ" (1.27µ) nickel AJ Engagement area 30µ" (.76µ) gold, terminal end area 100µ"/200µ" (2.54µ/5.08µ) -tin/lead, underplate of 50µ" (1.27µ) nickel</p>	<p><b>Code Housing Characteristics</b></p> <p>20 Tin plated receptacle 21 Tin plated</p> <p><b>Code Panel Mounting Options</b></p> <p>1 #4-40 threaded hole 2 #4-40 threaded hole with female screwlock 3 M-3 threaded hole</p>
---	---

## Stamped And Formed Contacts Solder-Cup And Straight PCB Termination

Standards: UL File: E149426  
Connectors according to: MIL C24308 - NFC 93425-HE5

### SPECIFICATIONS:

#### MATERIALS AND PLATINGS

Shells	Steel
Insulator	Glass-filled thermoplastic, UL 94V-0
Pin Contact	Brass, selected gold in mating area; 100µ" (2.54µm) min. tin-lead on termination area over 50µ" (1.27µm) min. nickel
Socket Contact	Phosphor bronze, selected gold in mating area; 100µ" (2.54µ) min. tin-lead on termination area over 50µ" (1.27µm) min. nickel
Rear Insert	Brass, 100µ" (2.54µm) min. nickel plated
Boardlock	Brass, 100µ" (2.54µm) min. nickel plated
Screwlock	Brass, 100µ" (2.54µm) min. nickel plated

#### ELECTRICAL DATA

Current Rating	Standard Density: 5A per contact
Voltage Rating	250V AC/ rms 50Hz
Withstanding Voltage	1000V AC/ rms 50Hz for one minute
Insulation Resistance	1000MΩ at 500V DC
Contact Resistance	20 mΩ max.

#### CLIMATIC DATA

Operating Temperature -67°F (-55°C) to +257°F (125°C)

#### MECHANICAL DATA

Single Contact Insertion Force 1.19 lb. (0.54 kg.) max.  
Single Contact Withdrawal Force 0.13 lb. (0.06 kg.) min.

Mating and Unmating Force  
Unit: lb. (kg.)

No. of Pos	SD	
	Mate (max.)	Unmate (min.)
9	3.05 (6.74)	0.36 (0.79)
15	5.09 (11.24)	0.46 (1.01)
25	8.44 (18.66)	0.81 (1.8)
37	12.51 (27.65)	1.1 (2.47)
50	14.65 (32.38)	1.6 (3.56)

Standard plating thicknesses

- gold flash
- 15µ" (0.381µm) gold
- 30µ" (0.76 µm) gold

## SD SERIES

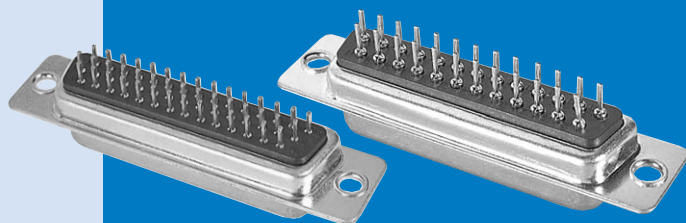

Amphenol's SD series, features precision stamped and formed contacts with closed entry contact cavities in insulator.

This series provides Amphenol's high standard of quality and reliability, to meet all of your commercial requirements.

- Industrial
- Telecom
- Any industry standard I / O connections

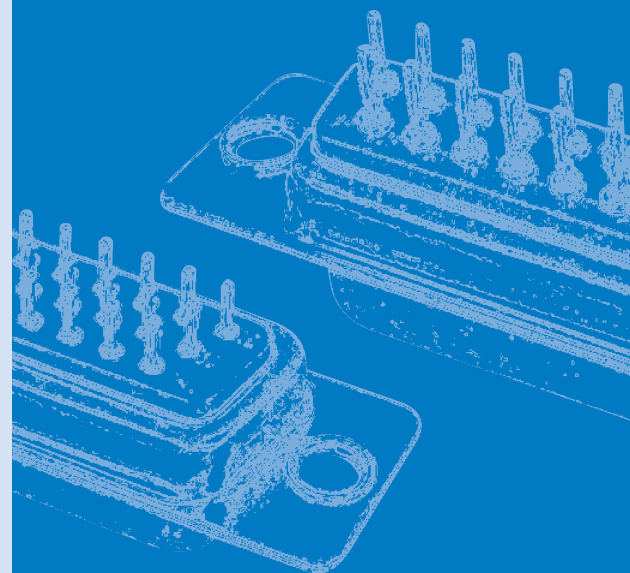

INCHES (MM)



DIMENSIONS

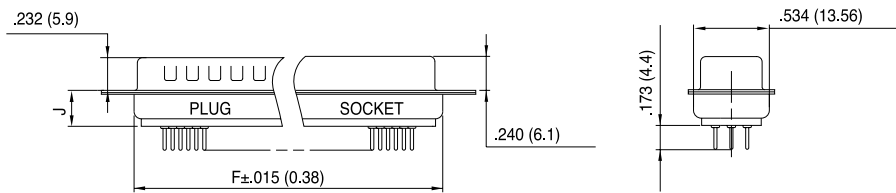
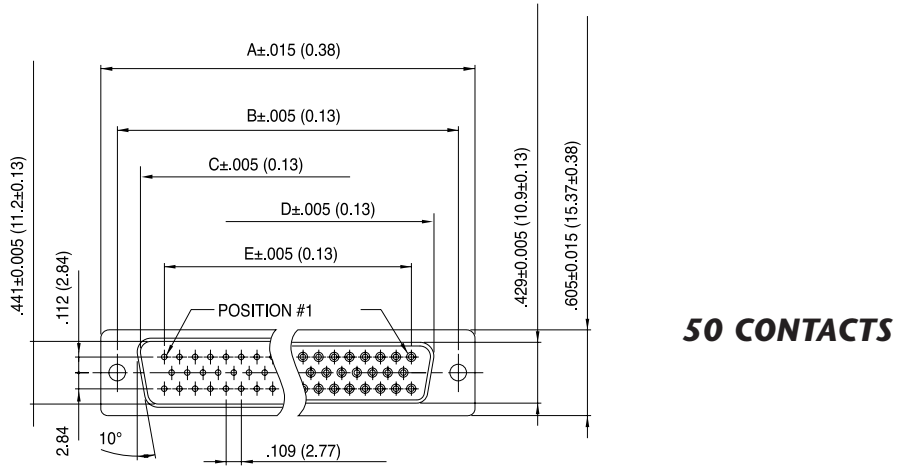
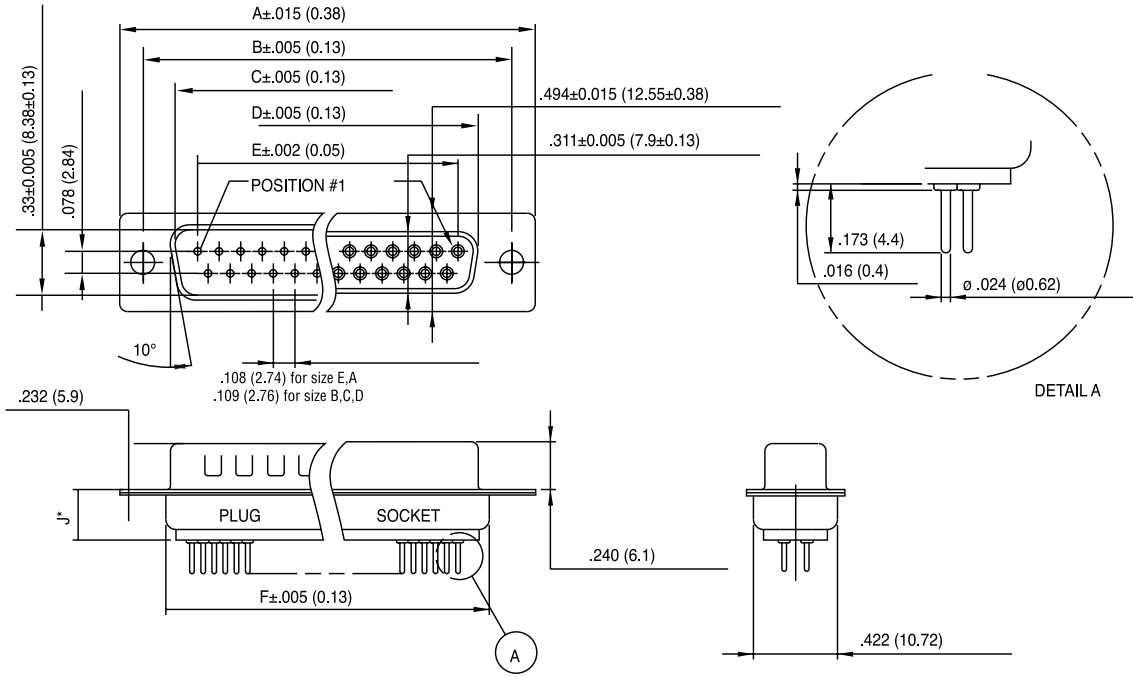

No. of Contacts	Dimensions					
	A	B	C	D	E	F
9	1.21 (30.84)	.98 (24.99)	.67 (16.92)	.64 (16.24)	.44 (11.09)	.76 (19.28)
15	1.54 (39.24)	1.31 (33.32)	.972 (24.7)	.97 (24.56)	.76 (19.39)	1.08 (27.51)
25	2.09 (53.04)	1.85 (47.04)	1.53 (38.96)	1.51 (38.38)	1.31 (33.24)	1.63 (41.30)
37	2.73 (69.32)	2.50 (63.50)	2.18 (55.42)	2.16 (54.76)	1.96 (49.86)	2.27 (57.71)
50	2.64 (67.06)	2.41 (61.11)	2.08 (52.86)	2.06 (52.34)	1.75 (44.32)	2.18 (55.3)

50 CONTACTS

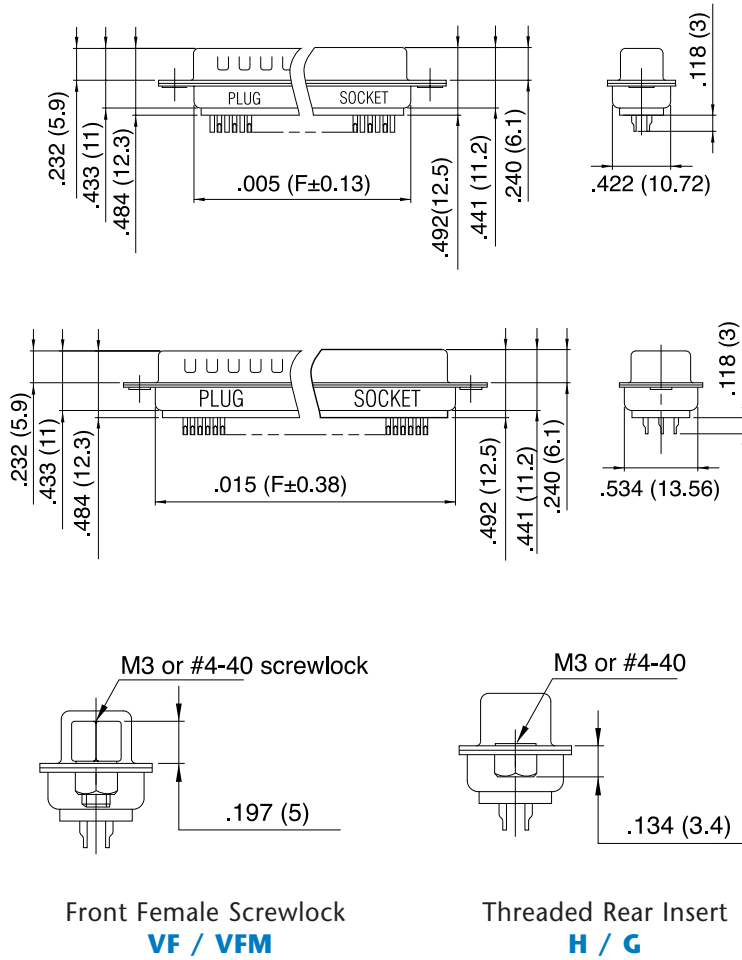

PANEL MOUNTING OPTION      PRINTED CIRCUIT BOARD TERMINATIONS

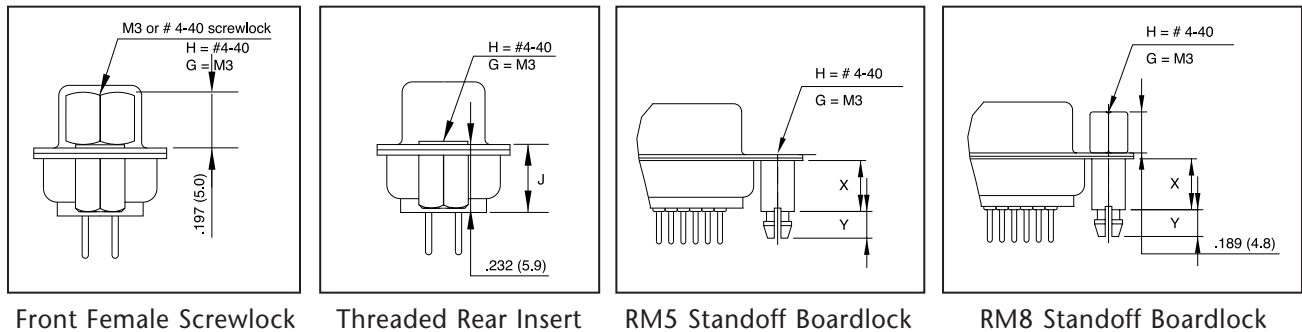

	RM5 RM8	RM5G RM8G
X	.236 (6.0)	.500 (12.7)
Y	.126 (4.2)	.126 (3.2)
J	.244 (6.2)	.465 (11.8)

INCHES (MM)

ORDERING INFORMATION

XXX - XX - X - X - XX - X - XXX - XXX - 309

Gold Flash	<p><b>77:</b> tinned shell for receptacle</p> <p><b>717:</b> tinned shell + dimples for plug</p>
15µ" (0.4µm)	<p><b>177:</b> tinned shell for receptacle</p> <p><b>777:</b> tinned shell + dimples for plug</p>

**SD:** standard density

**Shell size:** E, A, B, C, D

**Mounting Type:**

- H rear insert 4-40
- G rear insert M3
- blank standard rivet .120 (3.05)

H,G must also be used to specify the threading of RM5 or RM8 grounding tabs.

**Plating Option:**

valid only for 30µ" (0.76µm)

77 C309

or

717 C309

**Grounding Tabs\*:**

RM5 boardlock

RM8 boardlock + front screwlock

\*not available with s-cup

**Termination**

Straight for PCB = OL2

Blank = solder cup

**Contact Type:**

P pin

S socket

**Configuration:**

SD 9, 15, 25, 37, 50

For Filtered D-Sub, see page 56.

## Fixed Machined Contact Connector

- Standards:
- UL File: E119881
  - Connectors according to MIL C24308

### SPECIFICATIONS:

#### MATERIALS AND PLATINGS

<b>Shells</b>	Steel yellow chromated over zinc or tinned steel with or without dimples on plug connector
<b>Insulator</b>	Glass-filled thermoplastic, UL 94V-0
<b>Rear Insert</b>	Brass, 118µ" up to 197µ" (3µm up to 5µm) tinned over nickel 78µ" up to 118µ" (2µm up to 3µm)
<b>Boardlock</b>	Tin-lead plating 157µ" up to 236µ" (4µm up to 6µm) over nickel 78µ" up to 118µ" (2µm up to 3µm)
<b>Screwlock</b>	Brass, 236µ" up to 394µ" (6µm up to 10µm) tinned over nickel 78µ" up to 118µ" (2µm up to 3µm)
<b>Contacts</b>	D: brass DF: pin = brass Socket = copper alloy
<b>Right Angle Version</b>	Selective gold in mating area over 78µ" up to 118µ" (2µm up to 3µm) nickel; 118µ" up to 197µ" (3µm up to 5µm) tin-lead on termination area over 78µ" up to 118µ" (2µm up to 3µm) nickel
<b>Straight Version</b>	Full gold plating over 78µ" up to 118µ" (2µm up to 3µm) nickel

#### ELECTRICAL DATA

<b>Current Rating</b>	7.5 A
<b>Voltage Rating</b>	300 V AC/rms 50Hz
<b>Withstanding Voltage</b>	1000V AC/rms 50Hz for one minute
<b>Insulation Resistance</b>	5000MΩ
<b>Contact Resistance</b>	D: 8.5mΩ max. DF: 5mΩ max.

#### CLIMATIC DATA

<b>Operating Temperature</b>	D: -67°F (-55°C) to +185°F (85°C), peak at 257°F (125°C) DF: -67°F (-55°C) to + 257°F (125°C)
------------------------------	--

#### MECHANICAL DATA

No. of Contacts	Mate (max.)	Unmate (min.)
9 (size E)	6.74 (3.05)	0.79 (0.36)
15 (size A)	11.24 (5.09)	1.01 (0.46)
25 (size B)	18.66 (8.44)	1.8 (0.81)
37 (size C)	27.65 (12.51)	2.47 (1.1)
50 (size D)	32.38 (14.65)	3.56 (1.6)

INCHES (MM)

## D-DF SERIES

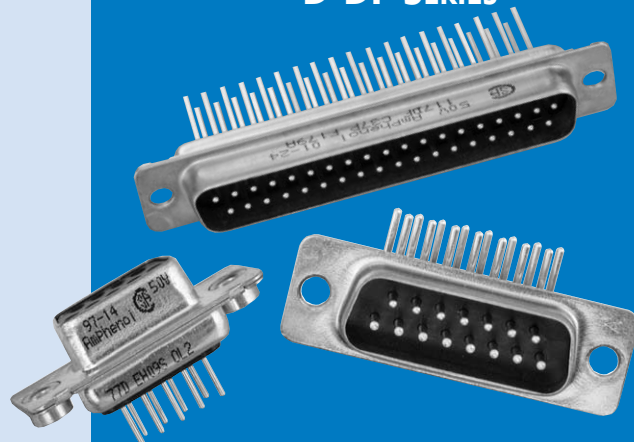

The Amphenol SD series features precision formed contacts, and 4 finger boardlocks.

This series gives you Amphenol's high standards of quality and reliability to meet all of your commercial requirements.

- Industrial
- Telecom
- Any industry standard I / O connections

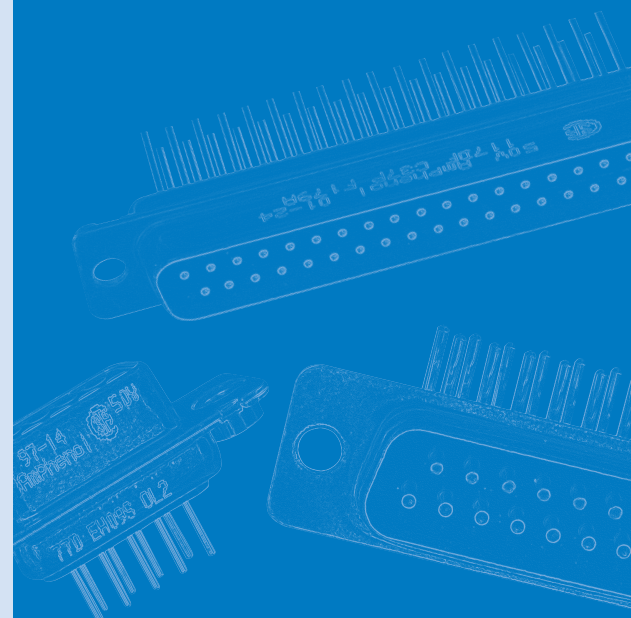

Without bracket

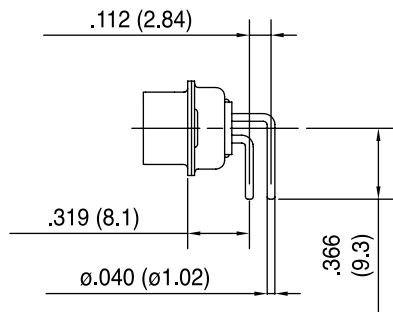

C

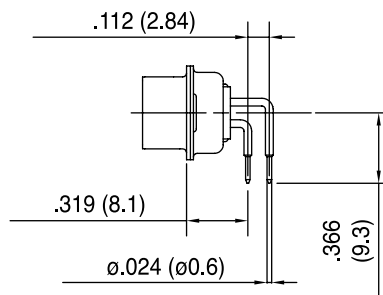

A4

Plastic bracket

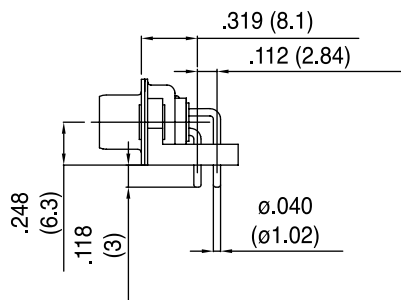

AJ3

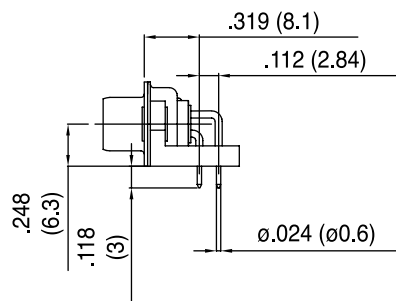

AJ4

Metal bracket

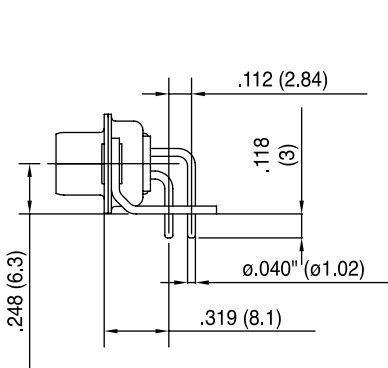

A

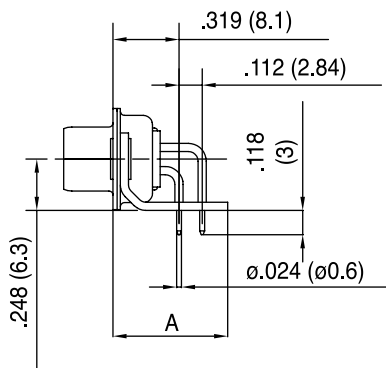

AM4 : A=.519 (13.2)  
AZ4 : A=.453 (11.5)

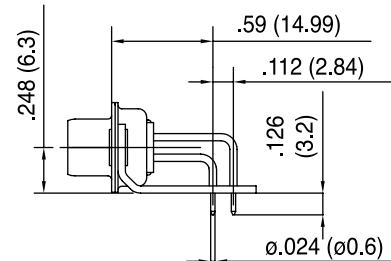

AM4B

50 contacts

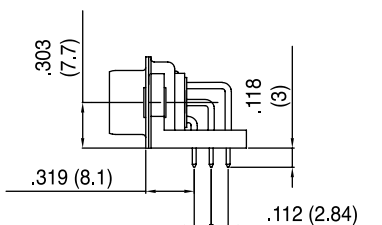



Without bracket

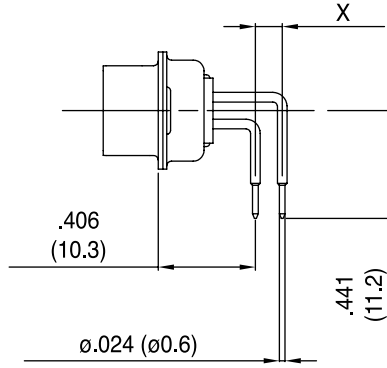

**1AON : X= .100 (2.54)**  
**1BON : X= .112 (2.84)**

Plastic bracket

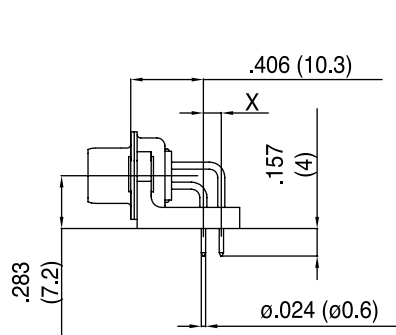

**1APN : X= .100 (2.54)**  
**1BPN : X= .112 (2.84)**

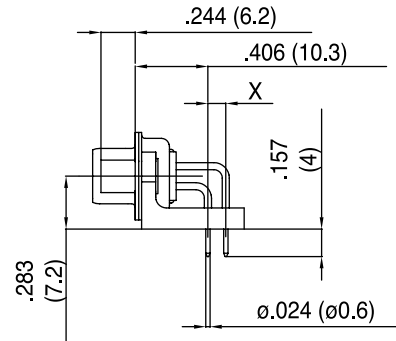

**1AUN : X= .100 (2.54)**  
**1BUN : X= .112 (2.84)**

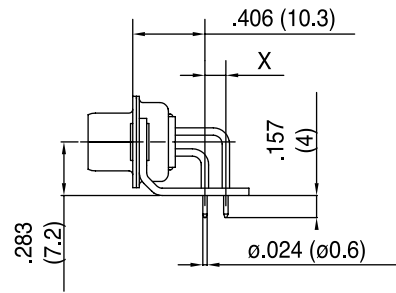

**1AMN : X= .100 (2.54)**  
**1BMN : X= .112 (2.84)**

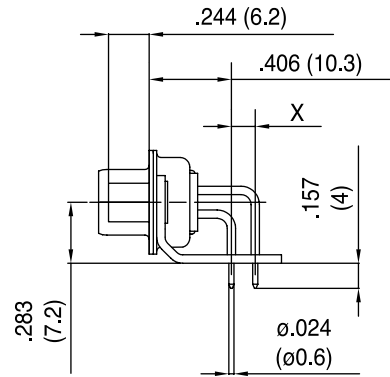

**1ATN : X= .100 (2.54)**  
**1BTN : X= .112 (2.84)**

50 contacts

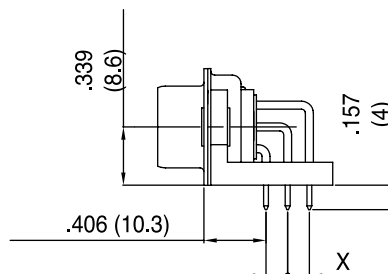

INCHES (MM)

Solder cup

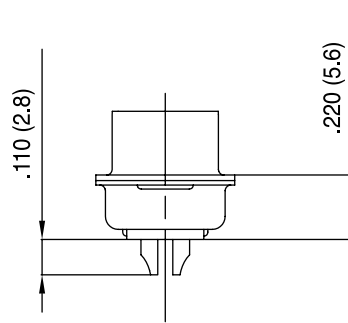

Wire Wrap

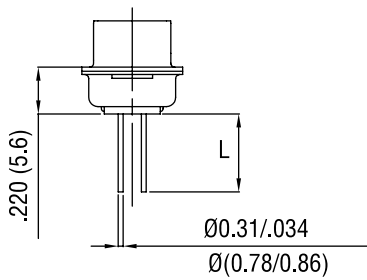

Termination	Nb of wraps	L
F179	2	.378 (9.6)
F179A	3	.512 (13)

Straight PCB

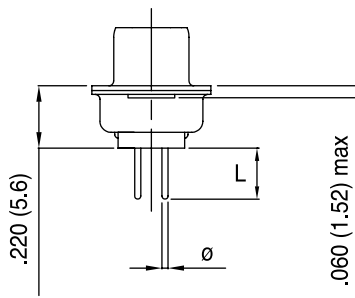

Termination	Ø	L
U	.024 (0.6)	.126 (3.2)
V	.040 (1.02)	.095 (2.4)
T	.024 (0.6)	.157 (4)
OL2	.02 (0.6)	.217 (5.5)

Grounding tabs

For straight termination

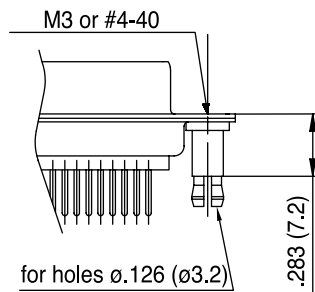

RM5

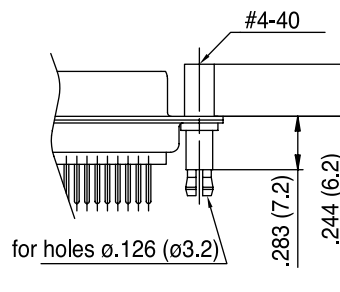

RM8

For R/A termination

FOR PCB .062 (1.6)

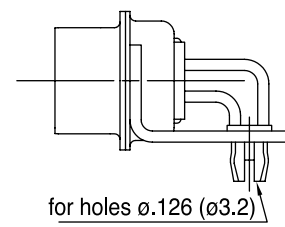

RM6

*For straight and R/A termination*

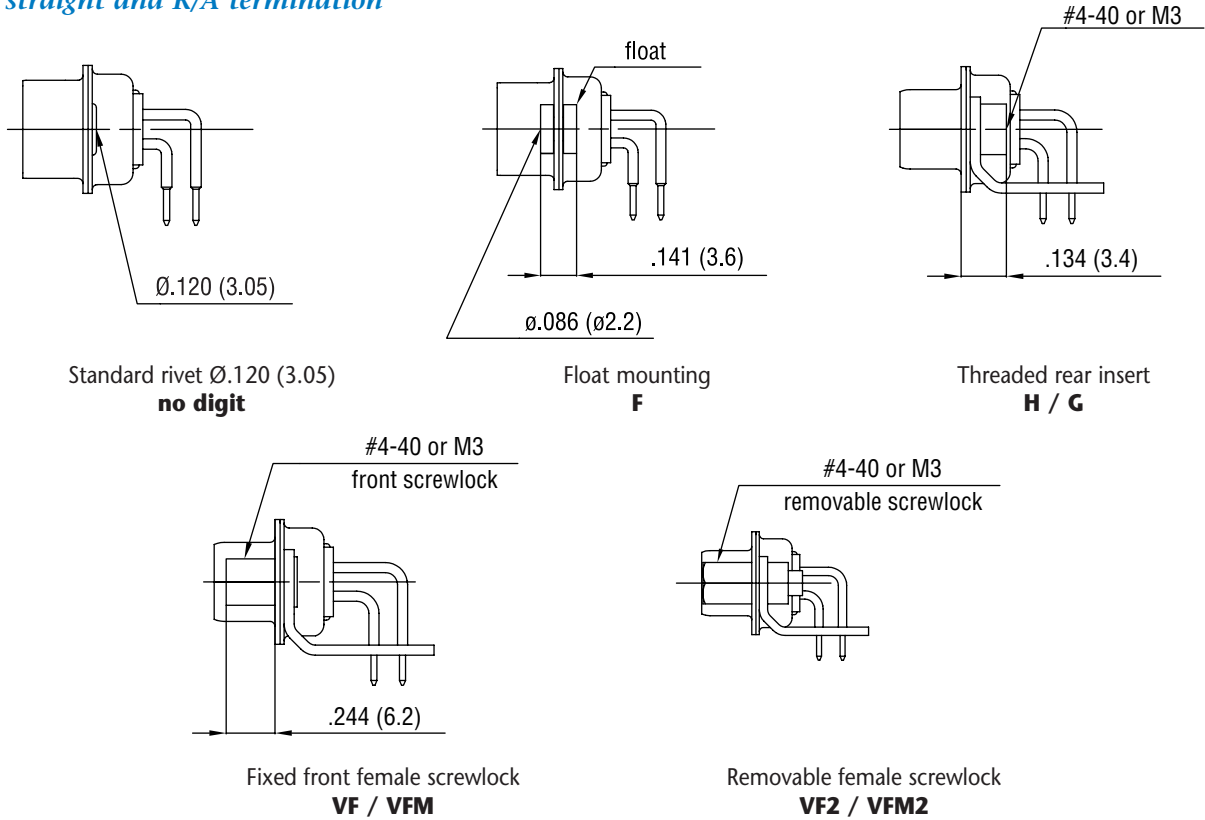

**RECOMMENDED PCB LAYOUT**

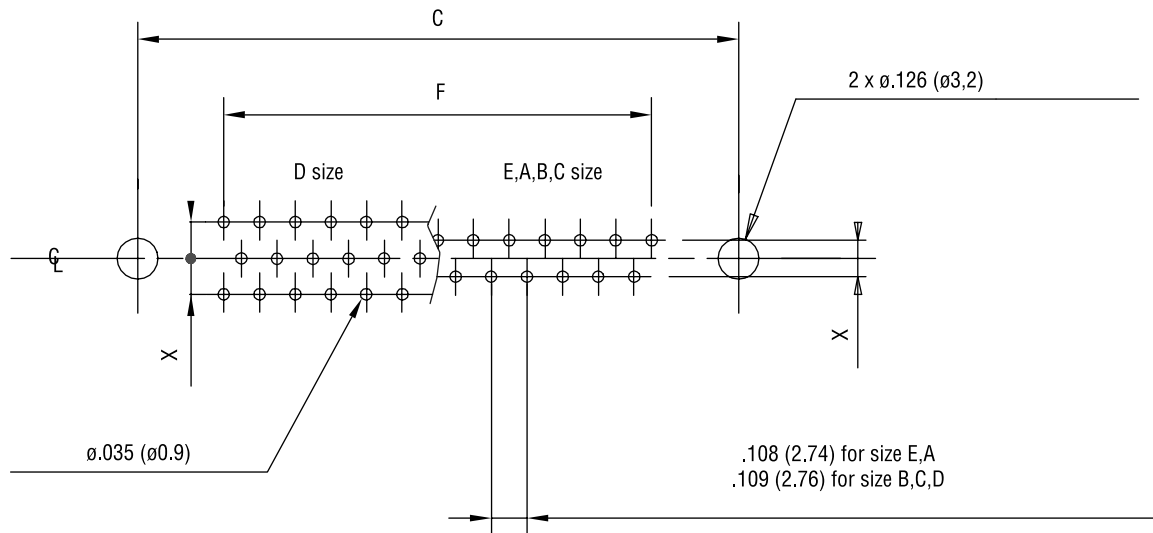

For straight PCB:  $X = .112$  (2.84)  
 For right angle PCB: MIL:  $X = .112$  (2.84)  
 European:  $X = .100$  (2.54),  $.112$  (2.84) in option

	size E	size A	size B	size C	size D
<b>C <math>\pm .004</math> (0.1)</b>	.984 (25)	1.311 (33.3)	1.85 (47)	2.5 (63.5)	2.406 (61.1)
<b>F <math>\pm .002</math> (0.05)</b>	.431 (10.96)	.755 (19.18)	1.304 (33.12)	1.956 (49.68)	1.74 (44.2)

INCHES (MM)

ORDERING INFORMATION

XXXXXX X X XX X XXXXX XXXX X

8µ" (0.2µm)	<b>17D:</b> yellow chromated shell <b>77D:</b> tinned shell for receptacle <b>717D:</b> tinned shell + dimples for plug
20µ" (0.5µm)	<b>17DF:</b> yellow chromated shell <b>77DF:</b> tinned shell for receptacle <b>717DF:</b> tinned shell + dimples for plug
30µ" (0.76µm)	<b>117DF:</b> yellow chromated shell <b>177DF:</b> tinned shell for receptacle <b>777DF:</b> tinned shell + dimples for plug

Shell size: E, A, B, C, D

Mounting Options:

- H rear insert 4-40
- G rear insert M3
- F float mounting
- no digit standard rivet .122 (ø 3.1)
- \*H, G must also be used to specify the threading of RM5 grounding tabs.

Configuration: 09, 15, 25, 37, 50

Contact type:

- P pin
- S socket

For specific product

Grounding tabs:

- RM5 for straight PCB mounting\*
- RM8 for straight PCB mounting + female lock
- RM6 for right angle PCB mounting
- VF front screwlock 4-40
- VFM front screwlock M3
- VF2 removable screwlock 4-40
- VF2M removable screwlock M3

Termination:

solder cup: no digit

Wire Wrap:

- F179 length .378 (9.6)
- F179A length .512 (13)

Straight PCB:

- U length .126 (3.2) tail ø.024 (ø0.6)
- V length .094 (2.4) tail ø.040 (ø1.02)
- T length .157 (4) tail ø.024 (ø0.6)
- OL2 length .216 (5.5) tail ø.024 (ø0.6)

Right Angle Connector:

MIL footprint

- without bracket: C tail ø.040 (ø1.02)
- A4 tail ø.024 (ø0.6)
- plastic bracket: AJ3 tail ø.040 (ø1.02)
- AJ4 tail ø.024 (ø0.6)
- metal bracket: A tail ø.040 (ø1.02)
- AM4 A ø.519 (13.2)
- AZ4 A ø.453 (11.5)
- AM4B footprint ø.590 (14.99)

European footprint

- without bracket: 1AON X .100 (2.54)
- 1BON X .112 (2.84)
- plastic bracket: 1APN X .100 (2.54)
- 1BPN X .112 (2.84)
- 1AUN X .100 (2.54)
- 1BUN X .112 (2.84)
- metal bracket: 1AMN X .100 (2.54)
- 1BMN X .112 (2.84)
- 1ATN X .100 (2.54)
- 1BTN X .112 (2.84)

■ : Standard options

For special request, please consult factory

For Filtered D-Sub, see page 56.

**Screw Termination**

**D-ST SERIES**

**SPECIFICATIONS:**

**MATERIALS AND PLATINGS**

Shells	Steel Tin plated
Insulator	Glass filled thermoplastic, UL94V-0
Contacts	Machined brass, full gold

**ELECTRICAL DATA**

Current Rating	7,5 A max.
Voltage Rating	300 V RMS at 50 Hz
Withstanding Voltage	1000 V RMS at 50 Hz
Insulation Resistance	> 5000 Ω at 500 V DC
Contact Resistance	< 5 Ω

**CLIMATIC DATA**

Operating Temperature	-67°F (-55°C) to +185°F (85°C), peak at 257°F (125°C)
Damp Heat	21 days 219°F(104°C - 95% HR)
Salt Spray	48 hours

**MECHANICAL DATA**

Cable Type	Solid or stranded
Cable Gauge	0,75 mm <sup>2</sup> max. (AWG 18) - For bigger wire, please consult factory
Screw Torque	0,05 mN max.
Mating Cycles	100 (class II) or 500 (class I)

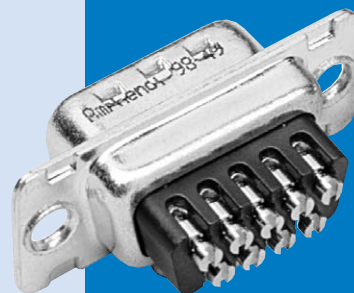

The Amphenol Screw Termination D-Sub series is especially designed for field applications.

These new connectors permit easy wiring without any specific tool; only a standard electrician's screwdriver is required. Due to their reduced overall dimensions, these connectors are compatible with all standard hoods and accessories.

- Industry - control of speed variators and calculators.
- Houses and public buildings - control of heating, air conditioning, lighting, shutters and fire safety.
- Infrastructures - fluids control, motorway tolls and street lighting.

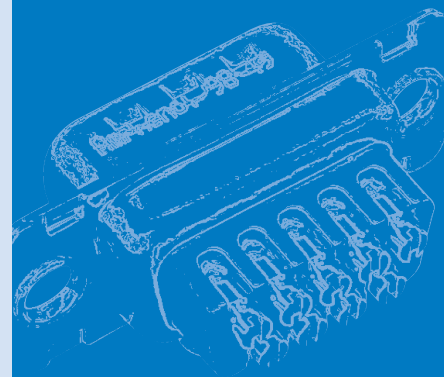

INCHES (MM)

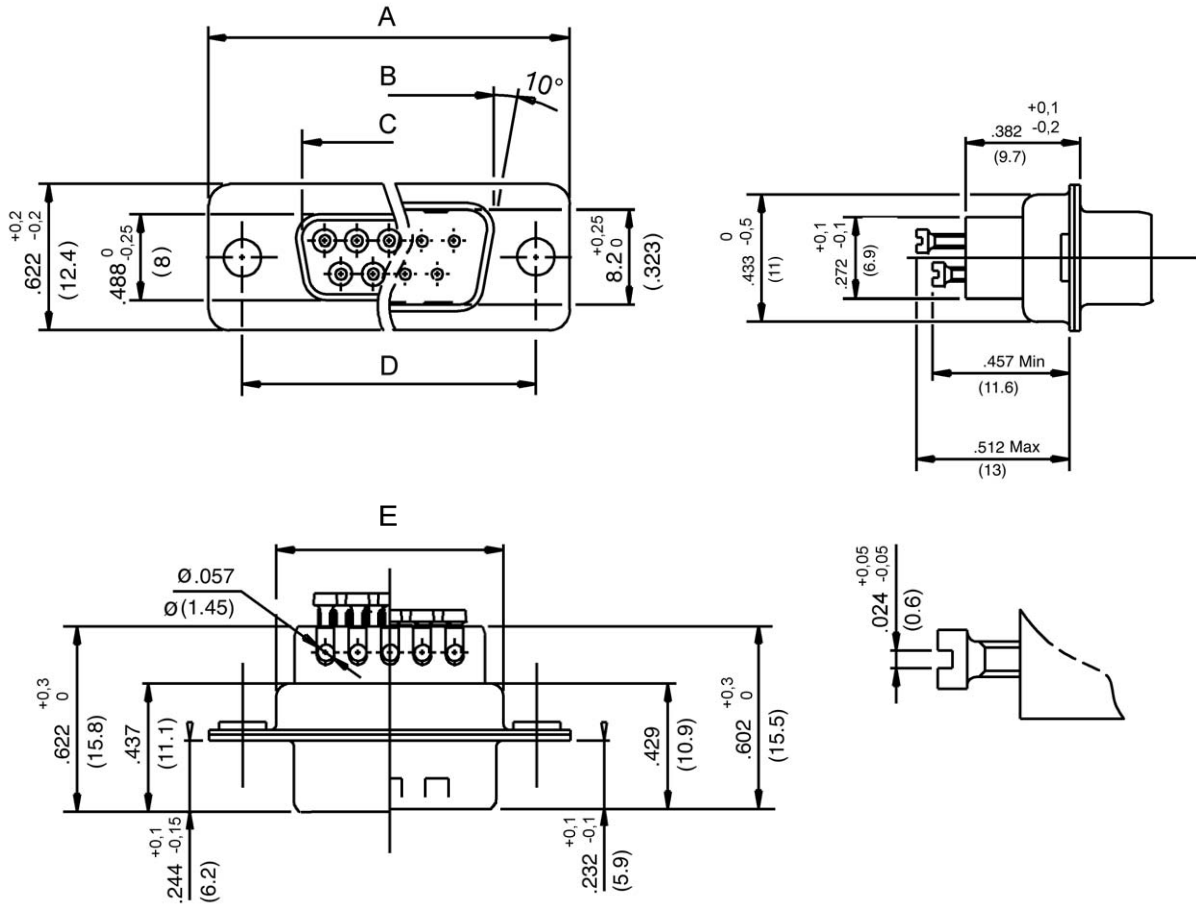

Cable stripping

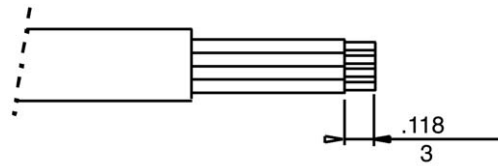

SIZE	A	B	C	D	E
	+0.10 (0.25) -0.10 (0.25)	0 -0.008 (0.2)	+0.008 (0.2) 0	+0.004 (0.1) -0.004 (0.1)	+0.004 (0.1) -0.016 (0.4)
9	1.209 (30.7)	.646 (16.4)	.661 (16.8)	.984 (25)	.370 (19.4)
15	1.535 (39)	.976 (24.8)	.988 (25.1)	1.311 (33.3)	1.091 (27.7)
25	2.083 (52.9)	1.516 (38.5)	1.528 (38.8)	1.850 (47)	1.630 (41.4)
37	2.724 (69.2)	2.161 (54.9)	2.177 (55.3)	2.500 (63.5)	2.280 (57.9)

ORDERING INFORMATION

**717D - E09 - P - ST - 1**

**Class II:** 77D Female connector  
717D Male connector, shells with dimples

**Class I:** 177D Female connector  
777D Male connector, shells with dimples

**Size and number of contacts** E09, A15, B25, C37

**Type of contact:** P Male  
S Female

**Kit connector + hood option:** (See following description)  
1 DPPK hood  
2 DSSK hood  
3 DTZK hood  
4 DVZK hood

**Contact termination:** ST Screw termination

PLASTIC HOODS



DPPK Straight cable entry



DSSK Angled cable entry

METALLIC HOODS



DTZK Straight cable entry

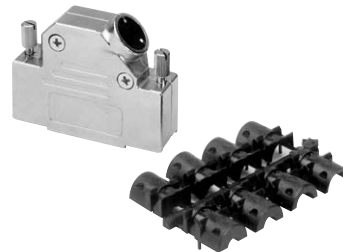

DVZK Angled cable entry

INCHES (MM)



## RR-HR SERIES

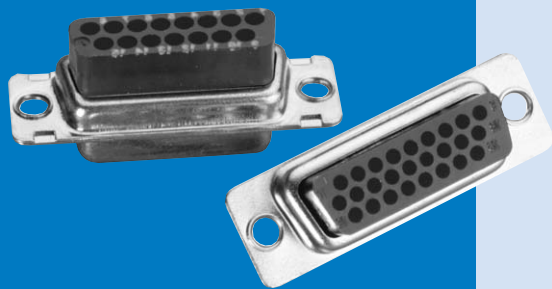

Designed for high volume production, Amphenol's rear release crimp connector and contacts provide significant cost savings.

- EMI / RFI shell configuration.
- Removable, reusable contacts.
- Automatic and manual tooling available.

- Industrial
- Telecom
- Any industry standard I / O connections

## Stamped And Formed Contacts Rear Release Crimp Connectors

- Standards:
- RR: UL File : E64911
  - HR: UL File : E149426
  - Connectors according to MIL C24308

### SPECIFICATIONS:

#### MATERIALS AND PLATINGS

Shells	Steel yellow chromated over zinc or tinned steel with or without dimples on plug connector
Insulator	Black glass-filled thermoplastic, UL 94V-0
Rear Insert	Brass, 118 $\mu$ " up to 197 $\mu$ " (3 $\mu$ m up to 5 $\mu$ m) tinned over nickel 78 $\mu$ " up to 118 $\mu$ " (2 $\mu$ m up to 3 $\mu$ m)
Screwlock	Brass, 236 $\mu$ " up to 394 $\mu$ " (6 $\mu$ m up to 10 $\mu$ m) tinned over nickel 78 $\mu$ " up to 118 $\mu$ " (2 $\mu$ m up to 3 $\mu$ m)

Contacts	Under plating	Crimp side
8 $\mu$ " (0.2 $\mu$ m) gold	78 $\mu$ " (2 $\mu$ m) nickel	gold flash or tin
20 $\mu$ " (0.5 $\mu$ m) gold	78 $\mu$ " (2 $\mu$ m) nickel	gold flash or tin
30 $\mu$ " (0.76 $\mu$ m) gold	78 $\mu$ " (2 $\mu$ m) nickel	gold flash or tin

#### ELECTRICAL DATA

Current Rating	5A
Voltage Rating	500V AC/rms 50Hz
Withstanding Voltage	RR: 1000V AC/rms 50Hz for 1 minute HR: 1000V AC/rms 60Hz for 1 minute
Insulation Resistance	RR: 5000M $\Omega$ HR: 1000M $\Omega$
Contact Resistance	10m $\Omega$ max.
Wire Size	20-28 AWG max. insulation out .05 (Ø1.27)

#### CLIMATIC DATA

Operating Temperature	67°F to 221°F (-55°C to +105°C)
-----------------------	---------------------------------

#### MECHANICAL DATA

##### Mating and Unmating Force

Unit: lb. (kg.)

No. of Contacts		Mate (max.)		Unmate (min.)	
RR	HR	RR	HR	RR	HR
9 (size E)	15 (size E)	6.74 (3.05)	8.42 (3.81)	0.79 (0.36)	1.14 (0.52)
15 (size A)	26 (size A)	11.24 (5.09)	13.16 (5.95)	1.01 (0.46)	2.32 (1.05)
25 (size B)	44 (size B)	18.66 (8.44)	20.46 (9.26)	1.8 (0.81)	3.02 (1.37)
37 (size C)	62 (size C)	27.65 (12.51)	29.78 (13.48)	2.47 (1.1)	3.88 (1.76)
50 (size D)	78 (size D)	32.38 (14.65)	34.96 (15.82)	3.56 (1.6)	4.46 (2.02)

STANDARD DENSITY RR

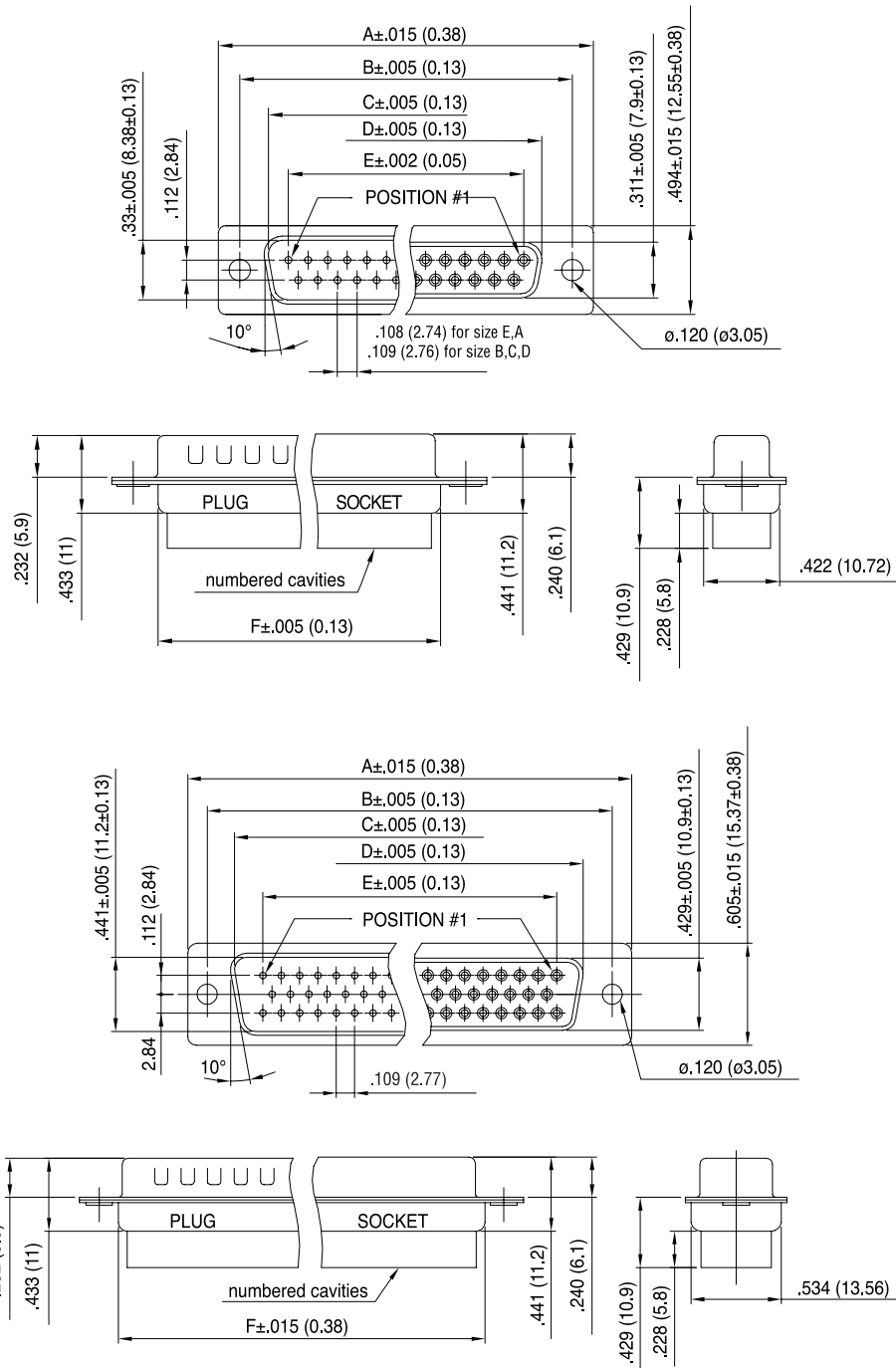

No. of Contacts	Dimensions					
	A	B	C	D	E	F
9	1.21 (30.84)	.98 (24.99)	.67 (16.92)	.64 (16.24)	.44 (11.09)	.76 (19.28)
15	1.54 (39.24)	1.31 (33.32)	.972 (24.7)	.97 (24.56)	.76 (19.39)	1.08 (27.51)
25	2.09 (53.04)	1.85 (47.04)	1.53 (38.96)	1.51 (38.38)	1.31 (33.24)	1.63 (41.30)
37	2.73 (69.32)	2.50 (63.50)	2.18 (55.3)	2.16 (54.76)	1.96 (49.86)	2.27 (57.71)
50	2.64 (67)	2.41 (61.11)	2.08 (52.86)	2.06 (52.34)	1.75 (44.32)	2.18 (55.3)

INCHES (MM)

HIGH DENSITY HR

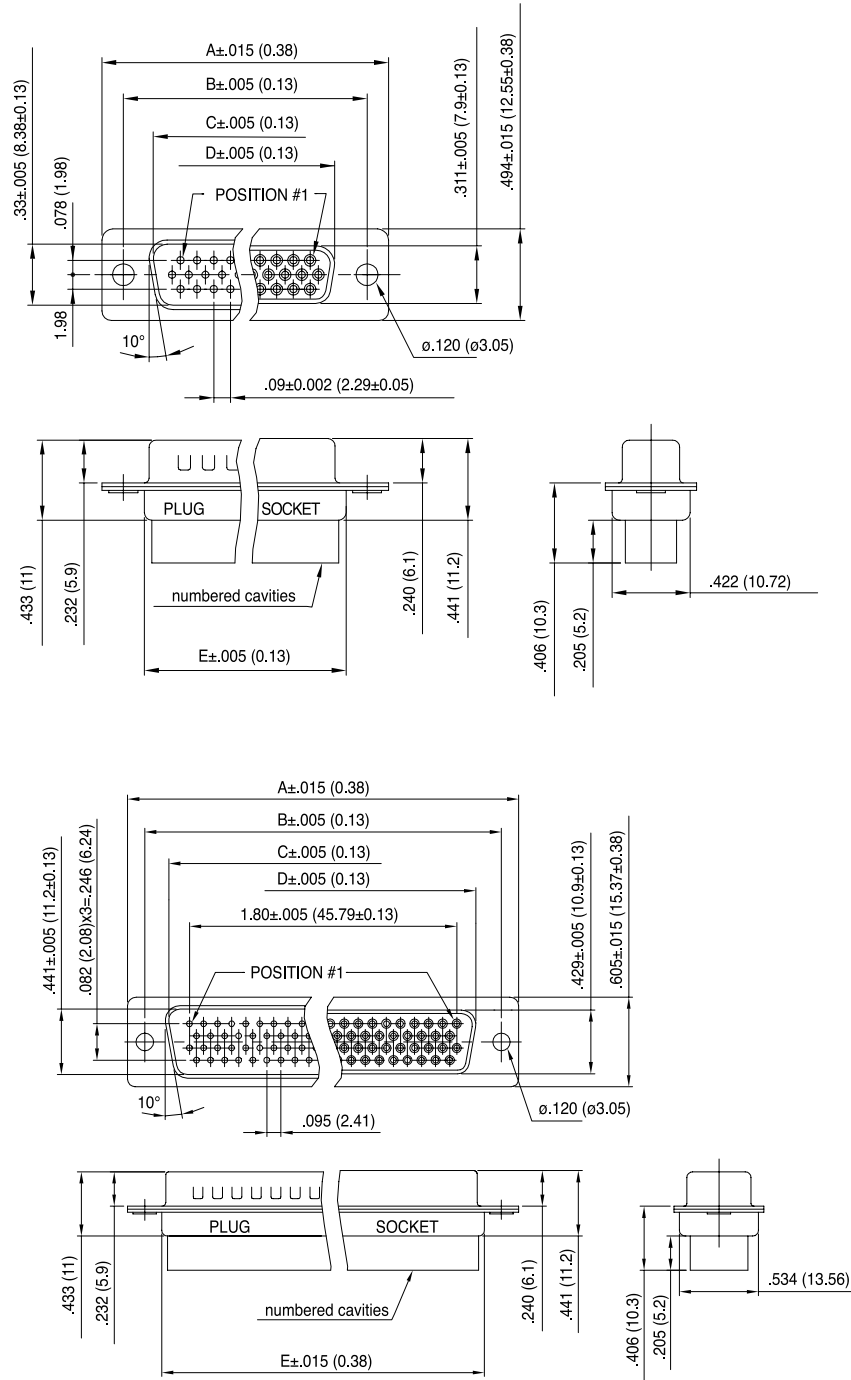

No. of Contacts	Dimensions				
	A	B	C	D	E
15	1.21 (30.84)	.98 (24.99)	.67 (16.92)	.64 (16.24)	.76 (19.28)
26	1.54 (39.24)	1.31 (33.32)	.972 (24.7)	.97 (24.56)	1.08 (27.51)
44	2.09 (53.04)	1.85 (47.04)	1.53 (38.96)	1.51 (38.38)	1.63 (41.30)
62	2.73 (69.32)	2.50 (63.50)	2.18 (55.42)	2.16 (54.76)	2.27 (57.71)
44	2.64 (67)	2.41 (61.11)	2.08 (52.86)	2.06 (52.34)	2.18 (55.3)

PANEL MOUNTING OPTION

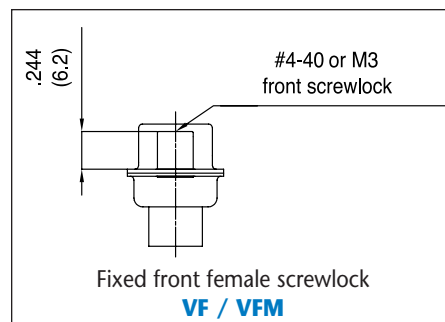
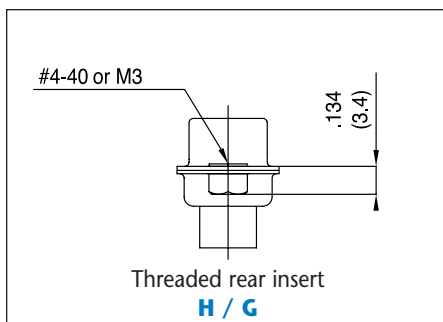
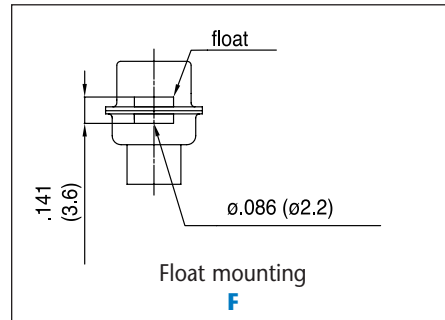
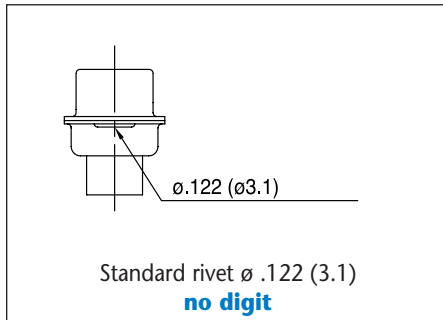

HIGH DENSITY

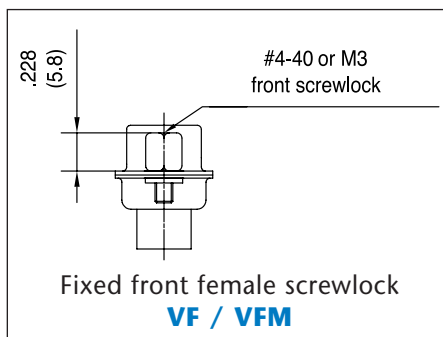
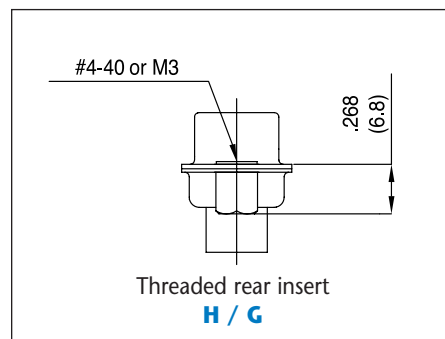
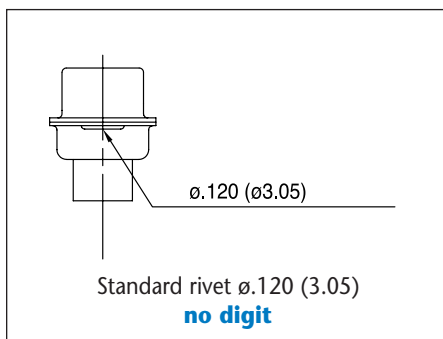

INCHES (MM)

CONTACTS

Standard density

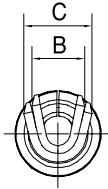

AWG	A	B	C
20-24	.071 (1.8)	.075 (1.9)	.098 (2.5)
24-28	.055 (1.4)	.059 (1.5)	.066 (1.7)

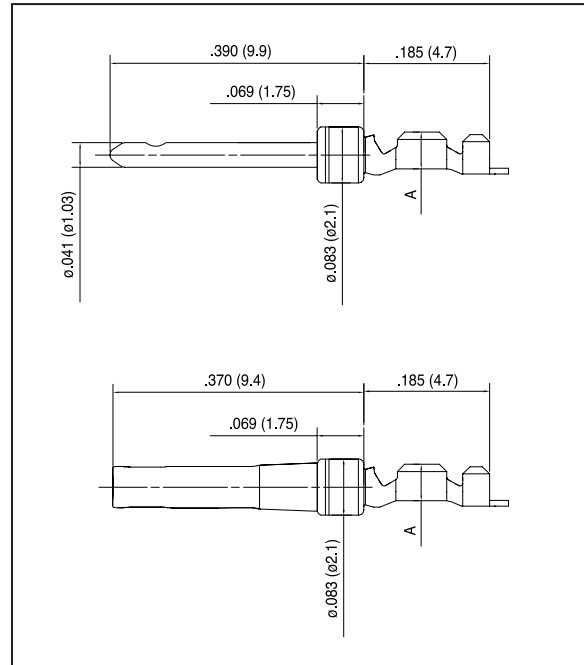

High density

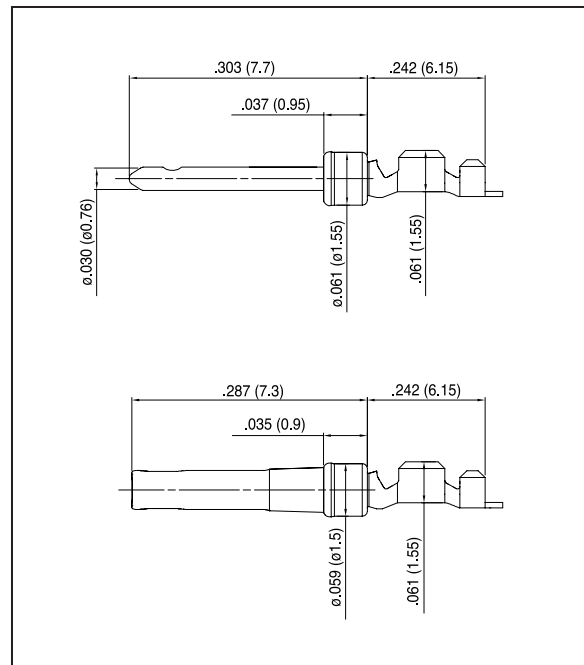
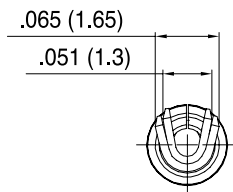

**ORDERING INFORMATION - RR (STANDARD DENSITY)**

*Housings*

**XXX - RR - X - X - XX - X - XXX**

**117:** yellow chromated shell  
**177:** tinned shell for receptacle  
**777:** tinned shell + dimples for plug

**Shell Size:** E, A, B, C, D

**Rear Mounting Type :**

- H** rear insert 4-40
- G** rear insert M3
- no digit** standard rivet ø.120 (3.05)
- F** float mounting

**Front Mounting Type :**

- VF** front screwlock 4-40
- VFM** front screwlock M3

**Contact Type:**

- P** pin
- S** socket

**Configuration:**

- 09, 15, 25, 37, 50

*Contacts*

**17 - RR - XX - X - XX - XXX**

**Wire Size:**

- D1:** 20 to 24 AWG
- D2:** 24 to 28 AWG

**Contact Type:**

- M** male
- F** female

**Full Gold Plating:**

- 01** 8µ\*(0.2µm)
- 02** 20µ\*(0.5µm)
- 04** 30µ\*(0.76µm)

**Selective Gold Plating:**

- 11** 8µ\*(0.2µm) Au  
+ 78µ\*(2µm) SnPb
- 12** 20µ\*(0.5µm) Au  
+ 78µ\*(2µm) SnPb
- 14** 30µ\*(0.76µm) Au  
+ 78µ\*(2µm) SnPb

**Packaging :**

- 100** bulkpack unit (100 cts)
- 400** reel of 400 cts
- 2K** reel of 2000 cts
- 10K** reel of 10000 cts (right feed reel)
- 10G** reel of 10000 cts (left feed reel)

REEL WINDING DIRECTION



Left to right feed reel: **G**

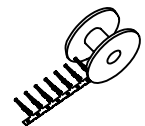

Right to left feed reel: **K**

***For special request, please consult factory***

INCHES (MM)

**ORDERING INFORMATION - HR (HIGH DENSITY)**

*Housings*

**XXX - HR - X - X - XX - X - XXX**

**117:** yellow chromated shell  
**177:** tinned shell for receptacle  
**777:** tinned shell + dimples for plug

**Shell Size:** E, A, B, C, D

**Rear Mounting type :**  
**H** rear insert 4-40  
**G** rear insert M3  
**no digit** standard rivet ø.120 (3.05)

**Front Mounting Type :**  
**VF** front screwlock 4-40  
**VFM** front screwlock M3

**Contact Type:**  
**P** pin  
**S** socket

**Configuration:**  
 15, 26, 44, 62, 78

*Contacts*

**17 - HR - D2 - X - XX - XXX**

**Wire Size:**  
24 to 28 AWG

**Contact Type:**  
**M** male  
**F** female

**Full Gold Plating:**  
**01** 8µ\* (0.2µm)  
**02** 20µ\* (0.5µm)  
**04** 30µ\* (0.76µm)

**Selective Gold Plating:**  
**11** 8µ\* (0.2µm) Au + 78µ\* (2µm) SnPb  
**12** 20µ\* (0.5µm) Au + 78µ\* (2µm) SnPb  
**14** 30µ\* (0.76µm) Au + 78µ\* (2µm) SnPb

**Packaging :**  
**5K** reel of 5000 cts (right feed reel)  
**5G** reel of 5000 cts (left feed reel)  
**10K** reel of 10000 cts (right feed reel)  
**10G** reel of 10000 cts (left feed reel)

REEL WINDING DIRECTION



Left to right feed reel: **G**      Right to left feed reel: **K**

**For special request, please consult factory**



**TOOLING FOR CRIMP CONTACTS**

For standard density crimp contacts: 17RR series

- Contact insertion and removal tool 17D 438 SP
- Hand crimp tool for single contacts AWG 20 to 28 17D 440 SP
- Hand crimp tool for reels of 400 contacts FA 0000 762
  - crimp dies: AWG 20 to 24 FA 0000 104
  - crimp dies: AWG 24 to 28 FA 0000 102
- Stripping box FE 0400
- Automatic crimp machine for reels of 2000 to 10000 contacts 970 MC
  - crimp dies: AWG 20 to 24 968 MC
  - crimp dies: AWG 24 to 28 972 MC

For high density crimp contacts: 17HR series

- Automatic crimp machine for reels of 2000 to 10000 contacts 970 MC
  - crimp dies: AWG 24 to 28 973 MC

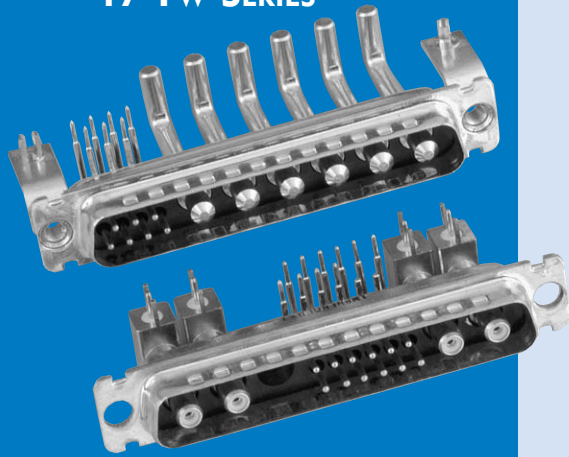

Amphenol's 17TW series hybrid D-Subminiature connectors are available with power, coax, high voltage and signal contacts assembled in the same connector body. These connectors are supplied with screw-machined contacts which are fixed in the insulator.

The board-mount product offering includes straight and right-angle terminations. The cable connectors are available in crimp and solder terminations. These connectors are compatible with the infra-red reflow soldering process. The 17TW series offers eighteen housing configurations in five shell sizes.

- Industrial
- Telecom
- Any industry standard I / O connections

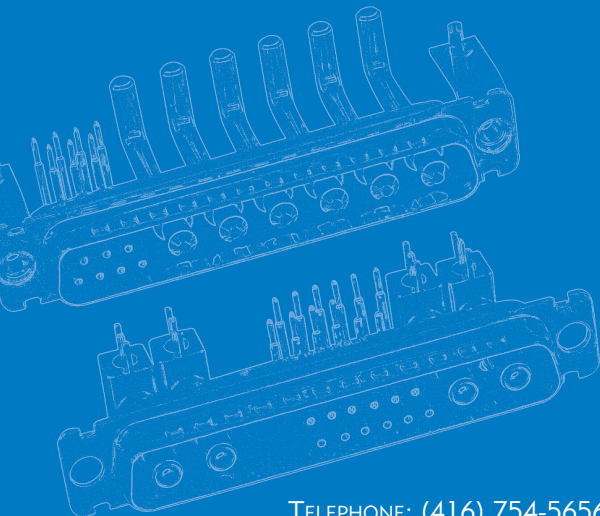

**SPECIFICATIONS:**

**MATERIALS AND PLATINGS**

<b>Shells</b>	Steel with tin plating or yellow chromate with or without grounding dimples High temperature black thermoplastic
<b>Insulators</b>	
<b>Signal Contacts</b>	
Female	Machined bronze
Male	Machined brass
Plating	16µ"(.40µm) or 30µ"(.76µm) gold over 79µ"(1.97µm) nickel
<b>Coax Contacts</b>	
Female	Machined bronze
Male	Machined brass
Plating	Inner conductor: 16µ"(.40µm) gold or 30µ"(.76µm) gold over 79µ"(1.97µm) nickel Outer ring: 10µ"(.25µm) gold over 79µ"(1.97µm) nickel Tinned. (Solder cup and crimp terminations are gold flash.)
<b>Terminations</b>	Tinned. (Solder cup and crimp terminations are gold flash.)
<b>Power Contacts</b>	
Female	Machined bronze
Male	Machined brass
Plating	Contacts: 16µ"(.40µm) gold or 30µ"(.76µm) gold over 79µ"(1.97µm) nickel
<b>Terminations</b>	Tinned. (Solder cup and crimp terminations are gold flash.)
<b>Brackets</b>	Steel with tin plating
<b>Front Jackscrews</b>	Brass with tin plating or yellow chromate
<b>Rear Clinch Nuts</b>	Brass with tin plating or yellow chromate
<b>Boardlocks:</b>	Bronze with tin plating
<b>Stand-offs</b>	Brass with tin plating

**ELECTRICAL DATA**

<b>Current Rating:</b> Signal Contacts	7.5 amps with 10 amp peaks
Power Contacts: PCB, Solder-Cup, Crimp	10 to 40 amps
	0.5 amps
<b>Current Rating:</b> Signal & Power Contacts	300 VRMS at 50 Hz
Coax Contacts	150 VRMS at 50 Hz
<b>Coax Contacts</b> Frequency range:	0 -1 GHz
Attenuation:	0.2 dB
V.S.W.R.:	1.4 (+0.04/GHz)
<b>Characteristic Impedance</b>	50 Ohms
<b>Dielectric Withstanding Voltage</b>	≥ 1000V R.M.S. at 50Hz
<b>Insulation Resistance</b>	≥ 5000 megaohms at 500 V D.C.
<b>Contact Resistance</b>	≤5 milliohms
<b>Shell Resistance (electrical grounding)</b>	≤1 milliohm

**CLIMATIC DATA**

<b>Shell Resistance (electrical grounding)</b>	≤1 milliohm
<b>Operating Temperature</b>	67°F (-55°C) to 311°F (+155°C) with peaks up to 356°F (180°C)
<b>Damp Heat</b>	56 days 104°F (40°C) at 95% RH
<b>Salt Spray</b>	48 hours

**MECHANICAL DATA**

<b>Contact Retention Force in Dielectric Material</b>	>40 N
<b>Maximum Mating and Unmating Force</b>	
with dimples	A size: 80 N B size: 100 N C size: 150 N D size: 180 N E size: 70 N
without dimples	A size: 50 N B size: 80 N C size: 120 N D size: 160 N E size: 30 N
<b>Process Compatibility</b>	IR - air convection: 500°F (260°C) for 20 seconds Soldering iron: 500°F (260°C) for 30 seconds
<b>Mating Cycles</b>	≥ 200 (16µ"(.41µm) gold) ≥ 500 (30µ"(.76µm) gold) Blind Mating System Available upon request
<b>Polarization</b>	Available with locking accessories, consult factory
<b>Derating Curves for Power Contacts:</b>	see page 51
<b>Pull-out Force for Crimped Contacts:</b>	see page 51
<b>Approvals:</b>	UL - File number: E 64911 / CSA - File number: LR 57744
<b>Shell Dimensions:</b>	See page 64

**SHELLS AND CONTACT PLATING**

**CLASS I**

30µ" (0.76µm) Au contacts gold plating  
500 mating cycles

**CLASS II**





16µ" (0.4µm) Au contacts gold plating  
200 mating cycles

Types	Shells and plating
117 TW	Yellow chromated shell Male and female
177 TW	Tin plated shell Female
777 TW	Tin plated shell with dimples Male only NOTE: Tin plated shells standard

Types	Shells and plating
17 TW	Yellow chromated shell Male and female
77 TW	Tin plated shell Female
717 TW	Tin plated shell with dimples Male only NOTE: Tin plated shells standard

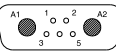
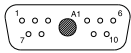
**HOUSING ARRANGEMENTS**

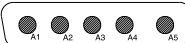
Male front view

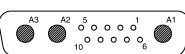
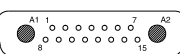
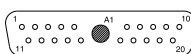
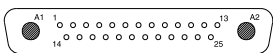
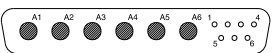
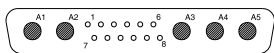
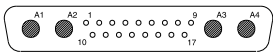
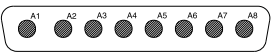
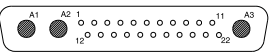
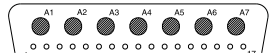
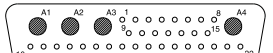
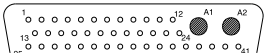
Arrangement ..... Shell size .....	 5W1 E	 7W2 A	 11W1 A
Arrangement ..... Shell size .....	 3W3 A	 5W5 B	 9W4 B
Arrangement ..... Shell size .....	 13W3 B	 17W2 B	 21W1 B
Arrangement ..... Shell size .....	 27W2 C	 13W6 C	 17W5 C
Arrangement ..... Shell size .....	 21WA4 C	 8W8 C	 25W3 C
Arrangement ..... Shell size .....	 24W7 D	 36W4 D	 43W2 D

ORDERING INFORMATION

XXX - X - XWX - X - XXXX - XX - XXXX - X

Contact & Shell Plating Prefix

Contact Plating	Shell Plating		
	Yellow Chromate	Tinned	Tinned & Indents*
16µ(0.4µm) gold over nickel	17TW	77TW	717TW
30µ(0.76µm) gold over nickel	117TW	177TW	777TW

\*plug only

Special Deviations

- High voltage contacts
- Fiberoptic contacts
- Consult factory

Board Mounting Options

(see page 40.)

- blank** .122 (3.10) mounting hole
- RM53** Snap-in standoff boardlock, M3 threaded on panel-mount side
- RM54** Snap-in standoff boardlock, 4 40 UNC 2B threaded on panel mount side
- RM83** Snap-in standoff boardlock with non-removable M3 threaded female screwlock on panel-mount side
- RM84** Snap-in standoff boardlock with non-removable 4-40 UNC 2B threaded female screwlock on panel-mount side

Panel Mounting Options

(see page 40.)

- blank** .122 (3.10) mounting hole
- 4F** 4-40 Front female screwlock
- 4R** 4-40 Rear screwlock
- 3F** M3 Front female screwlock
- 3R** M3 Rear screwlock
- A514** Blind mating system

Shell Size Configuration  
(see page 38.)

- E 5W1
- A 3W3
- A 7W2
- A 11W1
- B 5W5
- B 9W4
- B 13W3
- B 17W2
- B 21W1
- C 8W8
- C 13W6
- C 17W5
- C 21WA4
- C 25W3
- C 27W2
- D 24W7
- D 36W4
- D 43W2

(Consult factory for size D availability)

Loaded Contacts

**blank** Solder-cup signal contacts only - (order pwr/coax contacts separately) (See pages 45-47.)

- P3SY** 40 amp power and signal combination
- P2SY** 20 amp power and signal combination
- CSY** Coax and signal combination
- SY** Signal only
- P3Y** 40 amp power only (3W3, 5W5, 8W8)
- P2Y** 20 amp power only (3W3, 5W5, 8W8)
- CY** Coax only (3W3, 5W5, 8W8)

Board Mount Only

- | Code | Contact Type    |
|------|-----------------|
| P    | Pin (male)      |
| S    | Socket (female) |

For Filtered Combo's, see page 56.

*Straight version*

Blank: .122 (3.10) dia. mounting hole

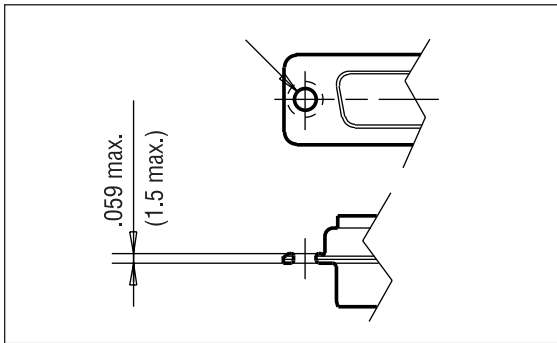

RM54: RM5 4.40 threaded  
 RM53: RM5 M3 threaded

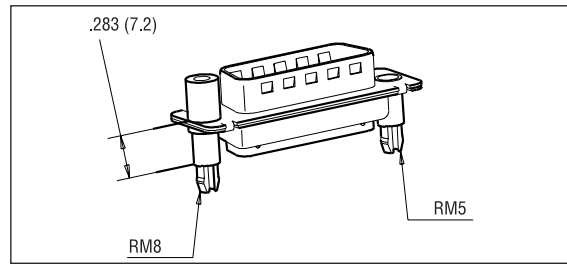

RM84: RM8 4.40 threaded  
 RM83: RM8 M3 threaded

A514: blind mating system

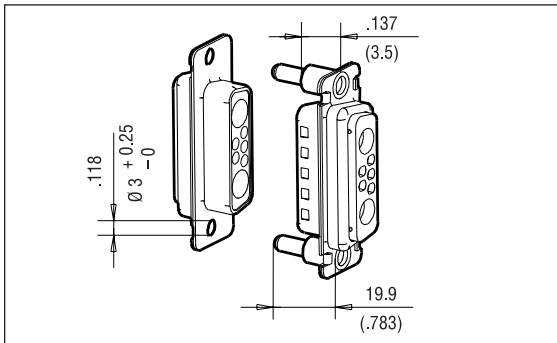

FM: float mounting system

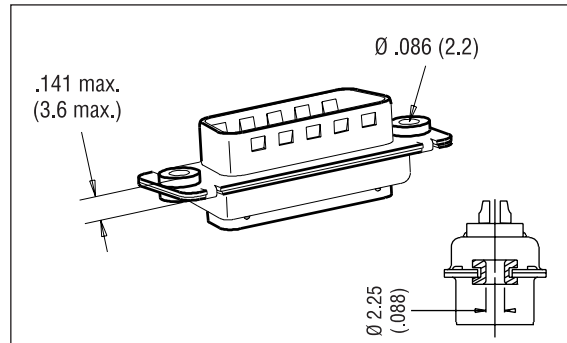

4R: 4.40 rear nut  
 3R: M3 rear nut

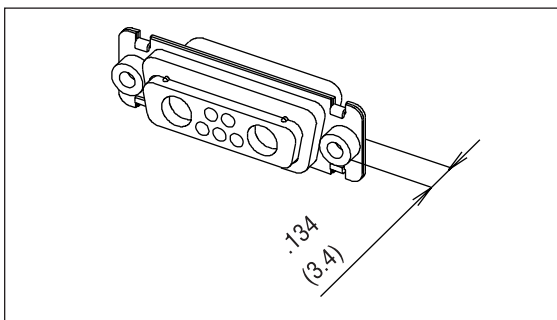

4F: 4.40 front female screwlock  
 3F: M3 front female screwlock

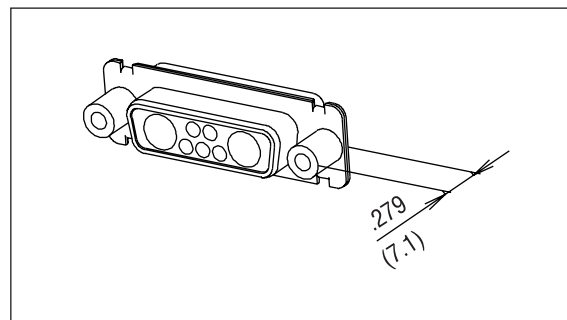

Signal tail .0236 (0.6) dia.  
 .063 (1.6) PCB  
 For other PCB thickness: consult factory.

Description		Dimensions	
		a	b
Power .126 (3.20) tail dia.	1	.177 (4.50)	.283 (7.2)
Power .0787 (2.0) tail dia.	1	.177 (4.50)	.283 (7.2)
Shielded	3	.157 (4.00)	.283 (7.2)
Signal	2	.196 (5.00)	.453 (11.50)

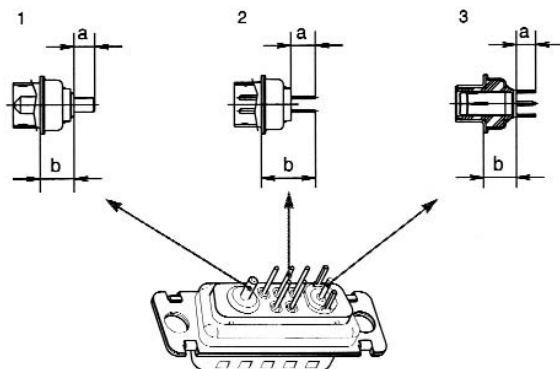

INCHES (MM)

RECOMMENDED BOARD LAYOUT (COMPONENT SIDE, MALE)

Straight .079 [2.00] and .126 [3.20] Power and Signal Contacts

P2Y P2SY  
P3Y P3SY

Right Angle .079 [2.00] Power and Signal Contacts

EP2V EP2SV (European Footprint)  
HP2V HP2SV (Mixed Footprint)  
MP2V MP2SV (US Footprint)

--- Denotes right angle dimensions

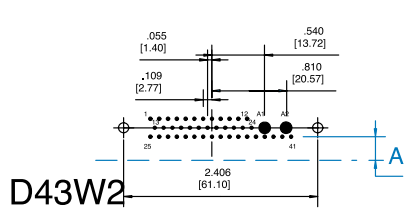
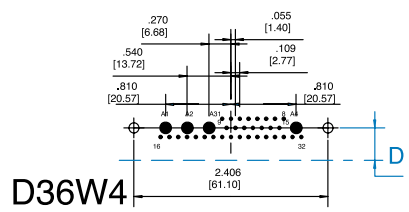
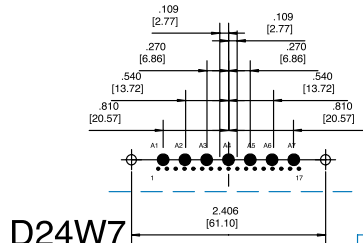
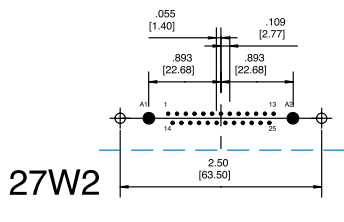
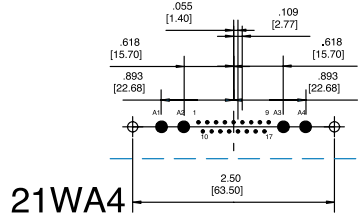
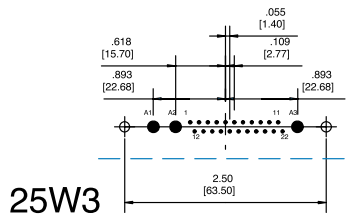
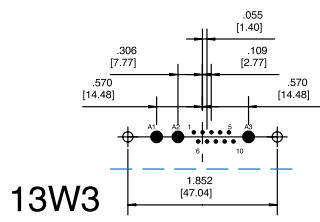
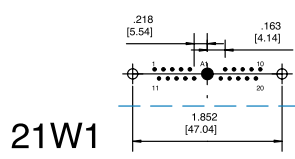
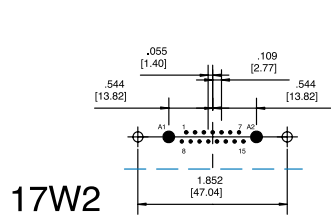
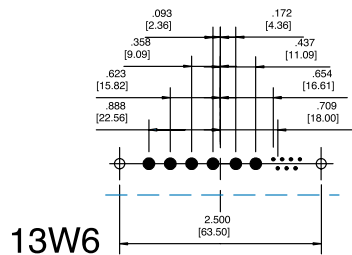
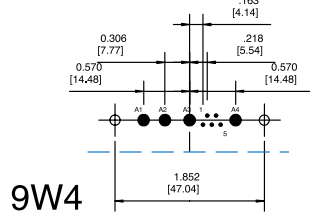
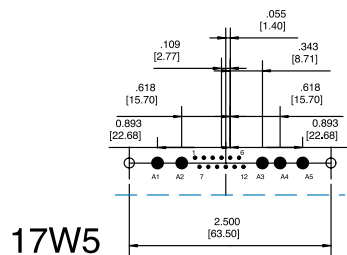
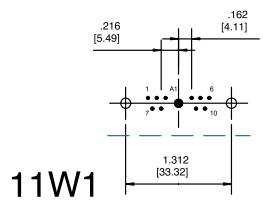
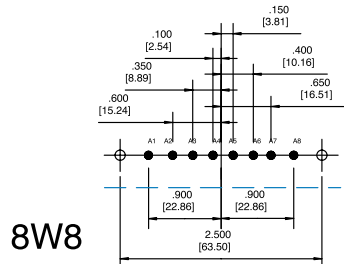
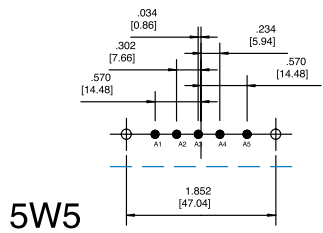
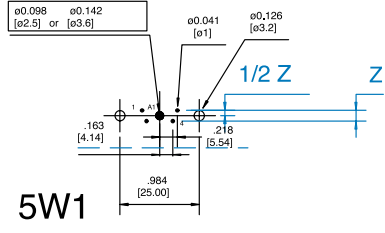
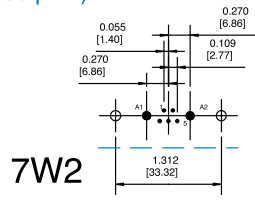
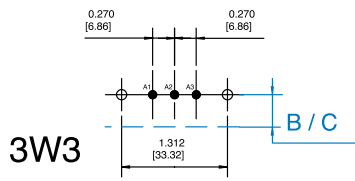

	A	B/C	D	Z
EURO FOOTPRINT	.370 [9.40]	.420 [10.67]	.470 [11.94]	.100 [2.54]
US FOOTPRINT	.283 [7.20]	.339 [8.62]	.395 [10.40]	.112 [2.84]
MIX FOOTPRINT	.370 [9.40]	.420 [10.67]	.470 [11.94]	.100 [2.54]

A = SIGNAL B = POWER C = BOARD LOCKS D = D SHELL BOARD LOCKS Z = PITCH

**RECOMMENDED BOARD LAYOUT**

Straight Coax and Signal Contacts  
 CY CSY  
 Right Angle Coax and Signal Contacts  
 HCV HCSV (Mixed Footprint)  
 MCV MCSV (US Footprint)

— — — Denotes right angle dimensions

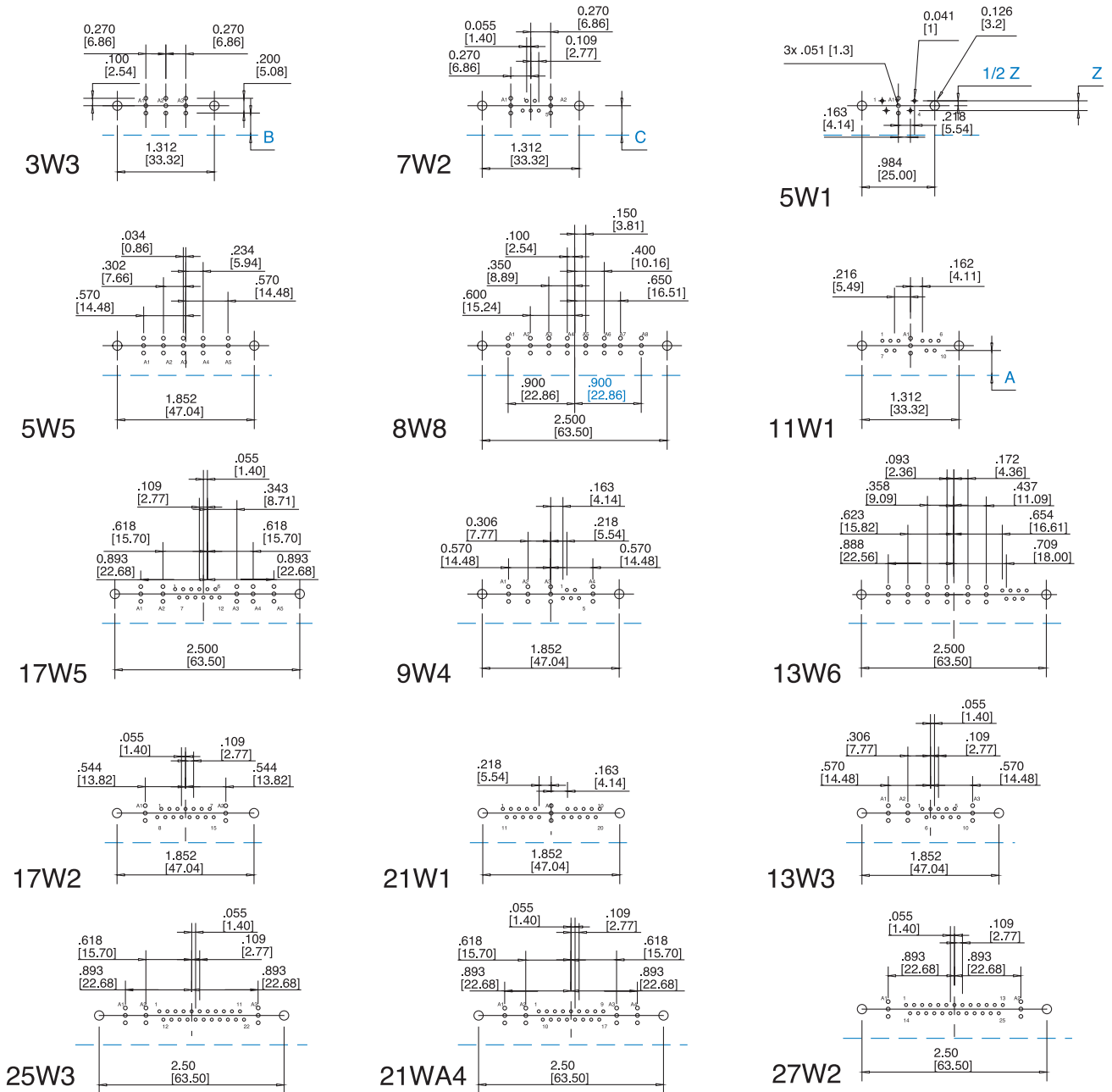

	A	B	C	Z
MIX FOOTPRINT	.370 [9.40]	.370 [9.40]	.420 [10.67]	.100 [2.54]
US FOOTPRINT	.283 [7.20]	.370 [9.40]	.339 [8.62]	.112 [2.84]

A = SIGNAL B = POWER C = BOARD LOCKS Z = PITCH

INCHES (MM)



RECOMMENDED BOARD LAYOUT

Right Angle .126 [3.20] Power and Signal Contacts

EP3V EP3SV (European Footprint)  
HP3V HP3SV (Mixed Footprint)  
MP3V MP3SV (US Footprint)

Denotes right angle dimensions

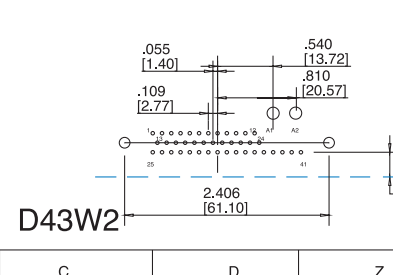
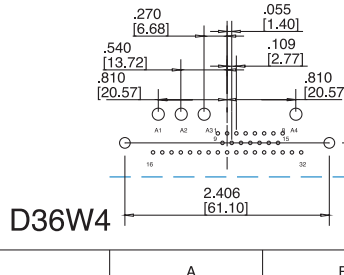
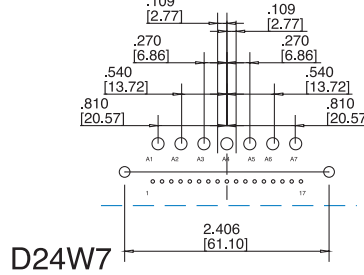
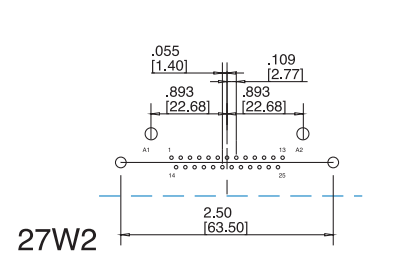
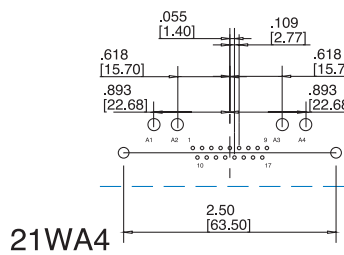
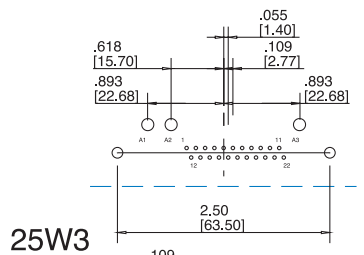
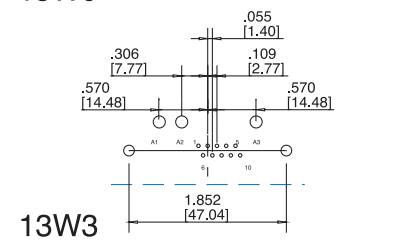
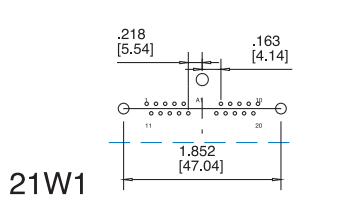
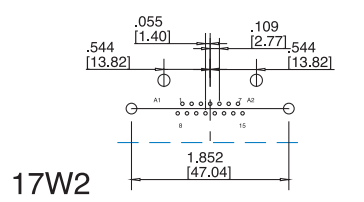
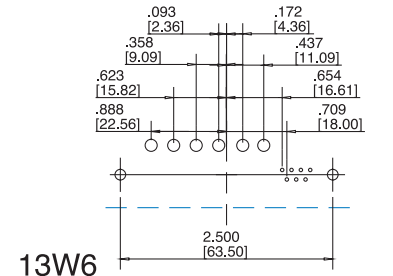
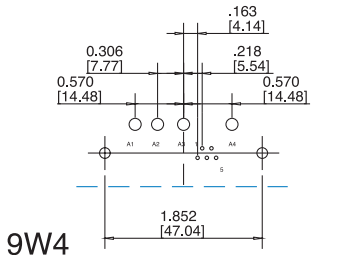
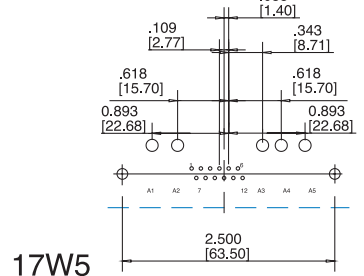
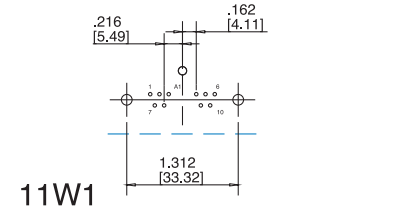
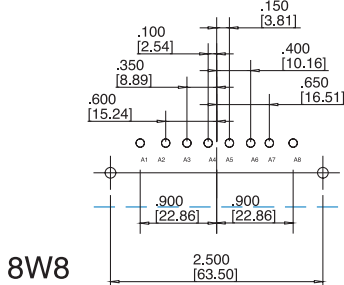
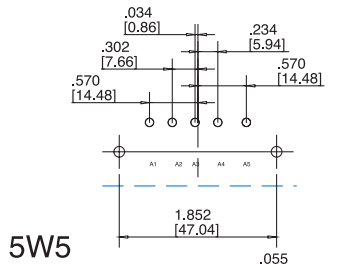
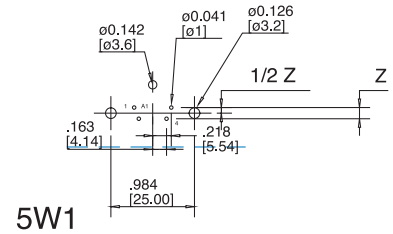
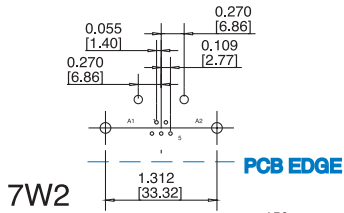
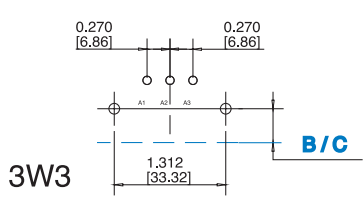

	A	B	C	D	Z
EURO FOOTPRINT	.370 [9.40]	.809 [20.56]	.420 [10.67]	.470 [11.94]	.100 [2.54]
US FOOTPRINT	.283 [7.20]	.809 [20.56]	.339 [8.62]	.395 [10.04]	.112 [2.84]
MIX FOOTPRINT	.370 [9.40]	.809 [20.56]	.420 [10.67]	.470 [11.94]	.100 [2.54]

A = SIGNAL B = POWER C = BOARD LOCKS D = D SHELL BOARD LOCKS Z = PITCH

**ORDERING INFORMATION**

XXX - X - XWX - X - XXXX - XX - XXXX - X

Contact & Shell Plating Prefix

Contact Plating	Shell Plating		
	Yellow Chromate	Tinned	Tinned & Indents*
16μ(0.4μm) gold over nickel	17TW	77TW	717TW
30μ(0.76μm) gold over nickel	117TW	177TW	777TW

\*plug only

Shell Size	Configuration (see page 38.)
E	5W1
A	3W3
A	7W2
A	11W1
B	5W5
B	9W4
B	13W3
B	17W2
B	21W1
C	8W8
C	13W6
C	17W5
C	21WA4
C	25W3
C	27W2
D	24W7
D	36W4
D	43W2

(Consult factory for size D availability)

Code	Contact Type
P	Pin (male)
S	Socket (female)

**Special Deviations**  
High voltage contacts  
Fiber Optic contacts  
Consult factory

**Board Mounting Options**  
(see page 48.)

- blank** .122 (3.10) mounting holes  
in metal brackets
- RM6** Snap-in boardlocks mounted  
on metal brackets

**Panel Mounting Options**  
(see page 48.)

- blank** .122 (3.10) mounting hole
- 4F** 4-40 Front female screwlock
- 4R** 4-40 Rear screwlock
- 3F** M3 Front female screwlock
- 3R** M3 Rear screwlock
- A514** Blind mating system:

**Loaded Contacts**  
(see page 48.)

- MP3SV** US footprint, 40 amp power and signal combination
- MP2SV** US footprint, 20 amp power and signal combination
- MCSV** US footprint, coax and signal combination
- MSV** US footprint, signal only
- MP3V** US footprint, 40 amp power only (3W3, 5W5, 8W8)
- MP2V** US footprint, 20 amp power only (3W3, 5W5, 8W8)
- MCV** US footprint, coax only (3W3, 5W5, 8W8)
- EP3SV** European footprint, 40 amp power and signal combination
- EP2SV** European footprint, 20 amp power and signal combination
- ESV** European footprint, signal only
- EP3V** European footprint, 40 amp power only (3W3, 5W5, 8W8)
- EP2V** European footprint, 20 amp power only (3W3, 5W5, 8W8)
- HP3SV** Mixed footprint, 40 amp power and signal combination
- HP2SV** Mixed footprint, 20 amp power and signal combination
- HCSV** Mixed footprint, coax and signal combination
- HSV** Mixed footprint, signal only
- HP3V** Mixed footprint, 40 amp power only (3W3, 5W5, 8W8)
- HP2V** Mixed footprint, 20 amp power only (3W3, 5W5, 8W8)
- HCV** Mixed footprint, coax only (3W3, 5W5, 8W8)

For Filtered Combo's, see page 56.

INCHES (MM)

High power contacts

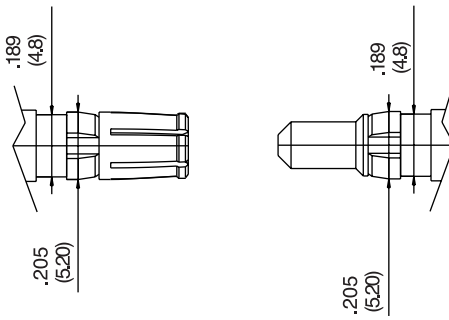

Solder cup version

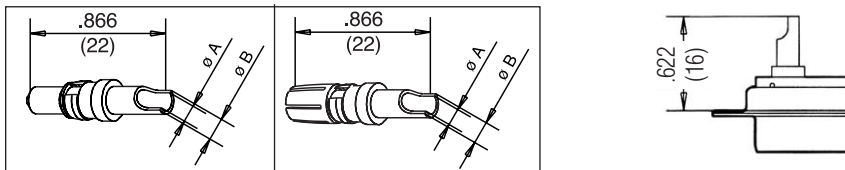

Plug	P/N	Socket	Current	Dimensions	
				A	B
17DM 53745-8		17DM 53744-7	10 to 20 Amp.	.071 (1.80)	.100 (2.55)
17DM 53745-7		17DM 53744-6	20 to 30 Amp.	.110 (2.80)	.145 (3.70)
17DM 53745-1		17DM 53744-1	30 to 40 Amp.	.189 (4.80)	.220 (5.60)

Trim dimensions: .295 (7.5)

Crimp version

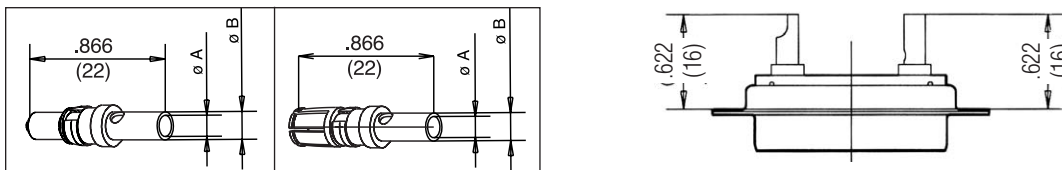

Plug	P/N	Socket	Current	Dimensions	
				A	B
17DM 53745-208		17DM 53744-207	10 to 20 Amp.	.071 (1.80)	.100 (2.55)
17DM 53745-207		17DM 53744-206	20 to 30 Amp.	.110 (2.80)	.145 (3.70)
17DM 53745-201		17DM 53744-201	30 to 40 Amp.	.189 (4.80)	.220 (5.60)

Trim dimensions: .295 (7.5)

*Straight shielded contacts*

**Crimp ferrule/Inner solder**

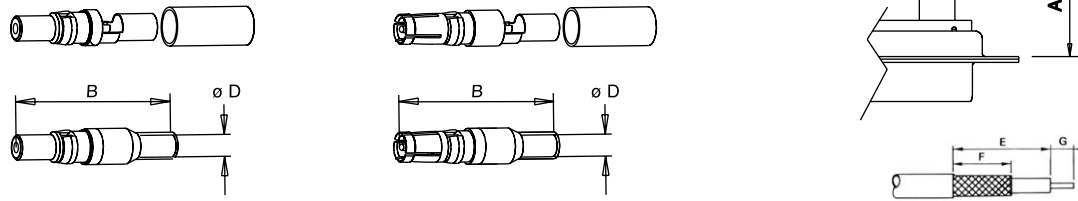

Type	P/N	Dimensions			Cable - RG	Trim dimensions		
		A Max.	B	D		E	F	G
plug	17DM 53740	.740 (18.8)	.929 (23.6)	.039 (1.0)	178 B/U	.311 (7.9)	.248 (6.3)	.078 (2)
plug	17DM 53740-1	.740 (18.8)	.929 (23.6)	.066 (1.7)	179 B/U 316 B/U	.311 (7.9)	.248 (6.3)	.078 (2)
plug	17DM 53740-3	.846 (21.5)	.929 (23.6)	.110 (2.8)	180 B/U	.374 (9.5)	.311 (7.9)	.078 (2)
plug	17DM 53740-5	.846 (21.5)	.929 (23.6)	.126 (3.2)	58 C/U	.374 (9.5)	.311 (7.9)	.078 (2)
socket	17DM 53742	.740 (18.8)	.929 (23.6)	.039 (1.0)	178 B/U	.311 (7.9)	.248 (6.3)	.078 (2)
socket	17DM 53742-1	.740 (18.8)	.929 (23.6)	.066 (1.7)	179 B/U 316 B/U	.311 (7.9)	.248 (6.3)	.078 (2)
socket	17DM 53742-3	.846 (21.5)	.929 (23.6)	.110 (2.8)	180 B/U	.374 (9.5)	.311 (7.9)	.078 (2)
socket	17DM 53742-5	.846 (21.5)	.929 (23.6)	.126 (3.2)	58 C/U	.374 (9.5)	.311 (7.9)	.078 (2)

**Ferrule and inner solder**

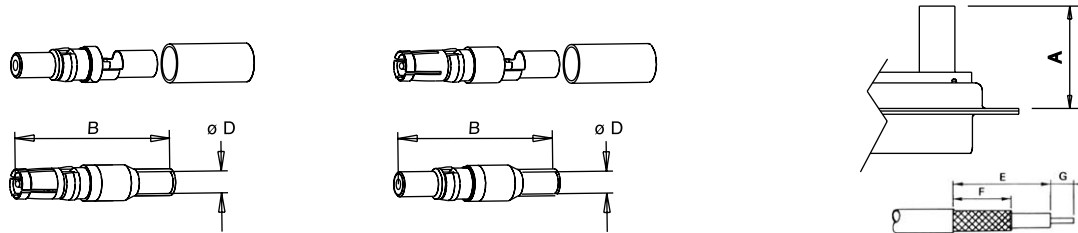

Type	P/N	Dimensions			Cable - RG	Trim dimensions		
		A Max.	B	D		E	F	G
short plug	17DM 53740-5000	.669 (17.0)	.858 (21.8)	.039 (1.0)	178 B/U	.311 (7.9)	.248 (6.3)	.078 (2)
plug	17DM 53740-5001	.740 (18.8)	.929 (23.6)	.066 (1.7)	179 B/U 316 B/U	.311 (7.9)	.248 (6.3)	.078 (2)
plug	17DM 53740-5002	.846 (21.5)	1.035 (26.3)	.110 (2.8)	180 B/U	.374 (9.5)	.311 (7.9)	.078 (2)
plug	17DM 53740-5005	.846 (21.5)	1.035 (26.3)	.126 (3.2)	58 C/U	.374 (9.5)	.311 (7.9)	.078 (2)
plug	17DM 53740-5008	.740 (18.8)	.929 (23.6)	.039 (1.0)	178 B/U	.311 (7.9)	.248 (6.3)	.078 (2)
short socket	17DM 53742-5000	.669 (17.0)	.858 (21.8)	.039 (1.0)	178 B/U	.311 (7.9)	.248 (6.3)	.078 (2)
socket	17DM 53742-5001	.740 (18.8)	.929 (23.6)	.066 (1.7)	179 B/U 316 B/U	.311 (7.9)	.248 (6.3)	.078 (2)
socket	17DM 53742-5002	.846 (21.5)	1.035 (26.3)	.110 (2.8)	180 B/U	.374 (9.5)	.311 (7.9)	.078 (2)
socket	17DM 53742-5004	.846 (21.5)	1.035 (26.3)	.126 (3.2)	58 C/U	.374 (9.5)	.311 (7.9)	.078 (2)
socket	17DM 53742-5006	.740 (18.8)	.929 (23.6)	.039 (1.0)	178 B/U	.311 (7.9)	.248 (6.3)	.078 (2)

**Right angled shielded contact**

**Crimp ferrule/Inner solder**

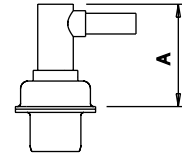
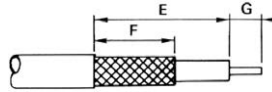
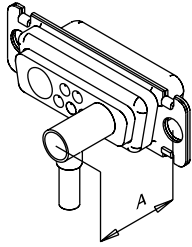

Type	P/N	Dimensions				Cable - RG	Trim dimensions		
		A Max.	B	C	D		E	F	G
plug	<b>17DM 53741</b>	.531 (13.5)	.732 (18.6)	.492 (12.5)	.039 (1.0)	178 B/U	.374 (9.5)	.232 (5.9)	.062 (1.6)
plug	<b>17DM 53741-1</b>	.531 (13.5)	.732 (18.6)	.492 (12.5)	.066 (1.7)	179 B/U 316 B/U	.374 (9.5)	.232 (5.9)	.062 (1.6)
plug	<b>17DM 53741-3</b>	.531 (13.5)	.732 (18.6)	.602 (15.3)	.110 (2.8)	180 B/U	.421 (10.7)	.311 (7.9)	.094 (2.4)
plug	<b>17DM 53741-4</b>	.531 (13.5)	.732 (18.6)	.602 (15.3)	.126 (3.2)	58 C/U	.421 (10.7)	.311 (7.9)	.094 (2.4)
socket	<b>17DM 53743-2</b>	.531 (13.5)	.732 (18.6)	.492 (12.5)	.039 (1.0)	178 B/U	.374 (9.5)	.232 (5.9)	.062 (1.6)
socket	<b>17DM 53743-3</b>	.531 (13.5)	.732 (18.6)	.492 (12.5)	.066 (1.7)	179 B/U 316 B/U	.374 (9.5)	.232 (5.9)	.062 (1.6)
socket	<b>17DM 53743-5</b>	.531 (13.5)	.732 (18.6)	.602 (15.3)	.110 (2.8)	180 B/U	.421 (10.7)	.311 (7.9)	.094 (2.4)
socket	<b>17DM 53743-6</b>	.531 (13.5)	.732 (18.6)	.602 (15.3)	.126 (3.2)	58 C/U	.421 (10.7)	.311 (7.9)	.094 (2.4)

**Ferrule and inner solder**

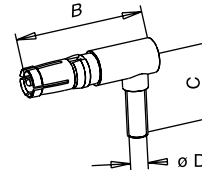
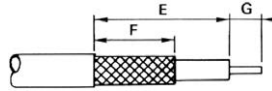
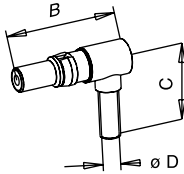

Type	P/N	Dimensions				Cable - RG	Trim dimensions		
		A Max.	B	C	D		E	F	G
plug	<b>17DM 53741-5000</b>	.531 (13.5)	.732 (18.6)	.492 (12.5)	.039 (1.0)	178 B/U	.374 (9.5)	.232 (5.9)	.062 (1.6)
plug	<b>17DM 53741-5001</b>	.531 (13.5)	.732 (18.6)	.492 (12.5)	.066 (1.7)	179 B/U 316 B/U	.374 (9.5)	.232 (5.9)	.062 (1.6)
plug	<b>17DM 53741-5003</b>	.531 (13.5)	.732 (18.6)	13.9 (.547)	.110 (2.8)	180 B/U	.421 (10.7)	.311 (7.9)	.094 (2.4)
plug	<b>17DM 53741-5004</b>	.531 (13.5)	.732 (18.6)	13.9 (.547)	.126 (3.2)	58 C/U	.421 (10.7)	.311 (7.9)	.094 (2.4)
socket	<b>17DM 53743-5000</b>	.531 (13.5)	.732 (18.6)	.492 (12.5)	.039 (1.0)	178 B/U	.374 (9.5)	.232 (5.9)	.062 (1.6)
socket	<b>17DM 53743-5001</b>	.531 (13.5)	.732 (18.6)	.492 (12.5)	.066 (1.7)	179 B/U 316 B/U	.374 (9.5)	.232 (5.9)	.062 (1.6)
socket	<b>17DM 53743-5003</b>	.531 (13.5)	.732 (18.6)	13.9 (.547)	.110 (2.8)	180 B/U	.421 (10.7)	.311 (7.9)	.094 (2.4)
socket	<b>17DM 53743-5004</b>	.531 (13.5)	.732 (18.6)	13.9 (.547)	.126 (3.2)	58 C/U	.421 (10.7)	.311 (7.9)	.094 (2.4)

**Crimping tool**

**Hand crimp tool**

227-0944 (without dies) (M 22 520/5-01)



RG cables	MIL reference	Amphenol P/N	dim. between 2 flat surface cavity	
			A	B
RG 58 C/U	M 22 520/5-05	227 1221-05	.213 (5.41)	-
RG 178 B/U	M 22 520/5-03	227 1221-03	-	.105 (2.67)
RG 179 B/U	M 22 520/5-03	227 1221-03	.128 (3.25)	-
RG 180 B/U	M 22 520/5-05	227 1221-05	-	.178 (4.52)

**MOUNTING OPTIONS**

*Right angle version*

Connectors come equipped with metal brackets

Blank: .122 (3.10) dia mounting hole

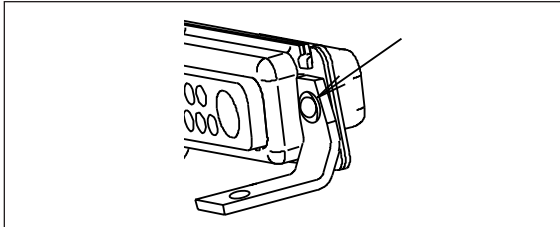

RM6: metal brackets + boardlock

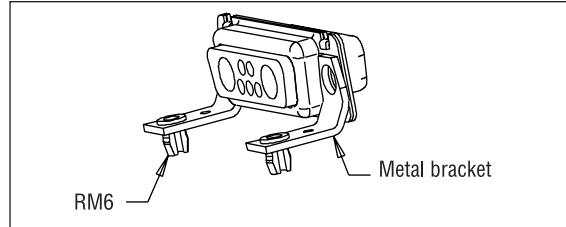

4R: 4.40 rear nut  
3R: M3 rear nut

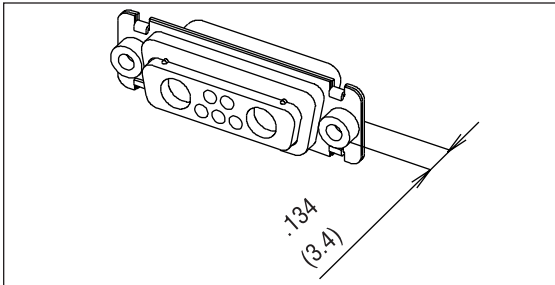

4F: 4.40 front female screwlock  
3F: M3 front female screwlock

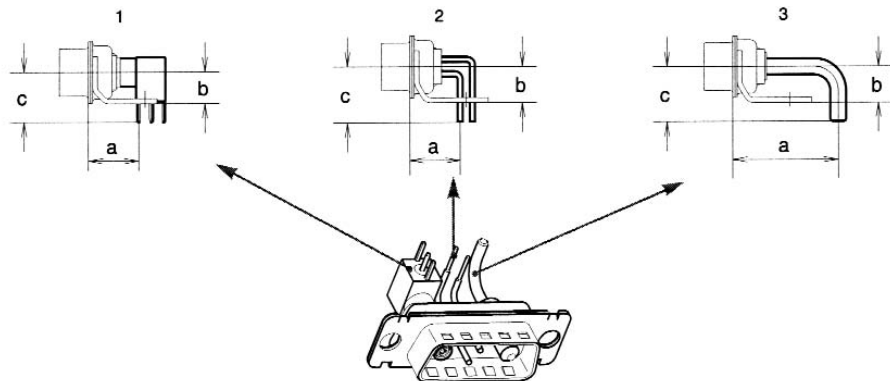
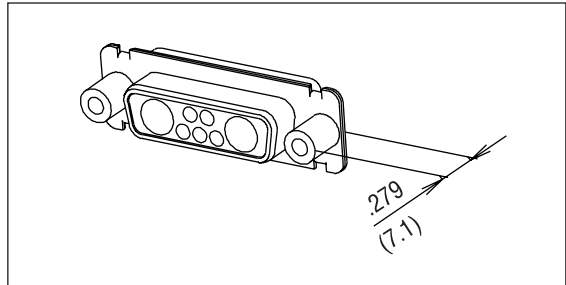

**CONTACT DIMENSIONS**

Signal tail .0236 (0.6) dia.  
.063 (1.6) PCB  
For other PCB thickness: consult factory.

Description	Drawing	Europe HE 5 pattern = European height European footprint pitch between 2 rows: .100 (2.54)			Mix Mixed pattern = MIL height European footprint pitch between 2 rows: .100 (2.54)			MIL MIL height MIL footprint pitch between 2 rows: .112 (2.84)		
		a	b	c	a	b	c	a	b	c
Shielded	1	-	-	-	.406 (10.30)	.248 (6.30)	.394 (10.00)	.406 (10.30)	.248 (6.30)	.394 (10.00)
Signal	2	.406 (10.30)	.283 (7.20)	.441 (11.20)	.406 (10.30)	.248 (6.30)	.374 (9.50)	.319 (8.10)	.248 (6.30)	.374 (9.50)
Power .0787 (2.0) tail dia.	3	.456 (11.57)	.283 (7.20)	.413 (10.50)	.456 (11.57)	.248 (6.30)	.374 (9.50)	.375 (9.52)	.248 (6.30)	.374 (9.50)
Power .126 (3.2) tail dia.	3	.845 (21.46)	.283 (7.20)	.413 (10.50)	.845 (21.46)	.248 (6.30)	.374 (9.50)	.845 (21.46)	.248 (6.30)	.374 (9.50)

NOTE: Dimensions above correspond to sizes E to C. Consult factory for size D connectors. Connector comes equipped with contacts and brackets.

INCHES (MM)

*Cabling instructions for shielded contacts*

*Straight crimp shielded contacts:*

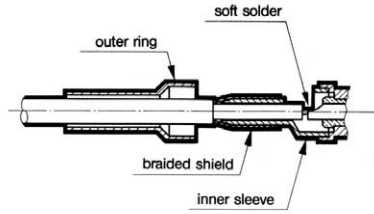

*inner solder contact  
outer crimp contact*

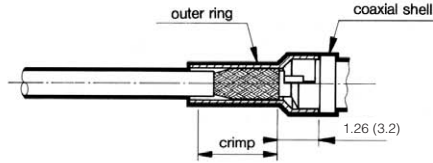

*Right angle crimp shielded contacts:*

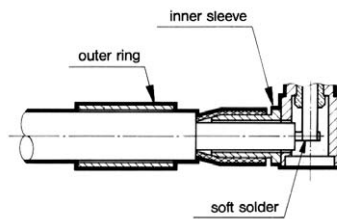

*inner solder contact  
outer crimp contact*

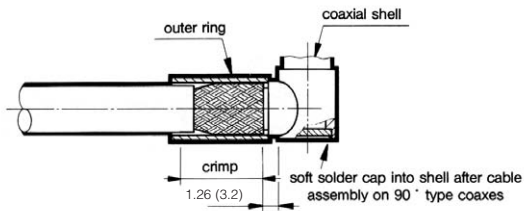

**ASSEMBLY METHOD**

1. Slide the outer ring over the cable jacket.  
Trim the cable according to the recommended dimensions.
2. Insert the cable dielectric and the center conductor inside the inner sleeve.
3. Solder the central conductor to the shielded center contacts.
4. Slide the outer ring towards the inner sleeve and recover the braid.
5. Using crimp hand tool equipped with the appropriate dies, crimp in the area defined.

**Solder straight shielded contacts**

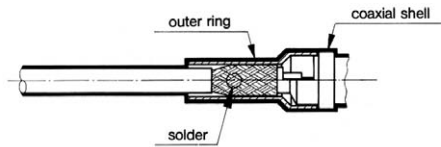
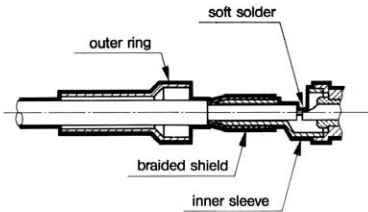

**Solder right angle shielded contacts**

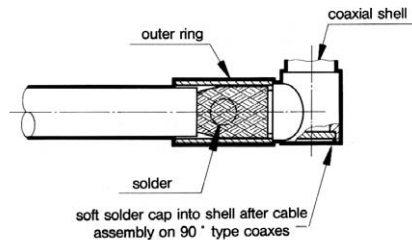
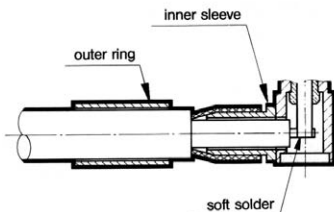

**ASSEMBLY METHOD**

1. Slide the outer ring over the cable jacket.  
Trim the cable according to the recommended dimensions.
2. Insert the cable dielectric and the center conductor inside the inner sleeve.
3. Solder the central conductor to the shielded center contacts.
4. Slide the outer ring towards the inner sleeve and recover the braid.
5. Solder by introducing metal through the outer ring hole.



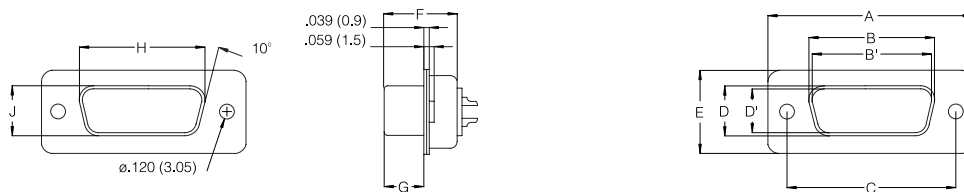

Shell Size	Contact P: Pin S: Socket	A ±.010 (±0.25)	B 0/- .008 (0/-0.20)	B' +.008/0 (+0.20/0)	C ±.004 (±0.10)	D 0/- .010 (0/-0.25)	D' +.010/0 (+0.25/0)	E ±.008 (±0.20)	F +.002/- .008 (+0.05/-0.20)	F' +.004/- .008 (+0.10/-0.20)	G +.004/.008 (+0.10/-0.20)	G' ±.004 (±0.10)	H +.004/- .016 (+0.10/-0.40)	J 0/- .020 (0/-0.50)
E	P	1.209 (30.7)		.661 (16.8)	.984 (25.0)		.323 (8.2)	.488 (12.4)		.429 (10.9)		.232 (5.9)	.764 (19.4)	.433 (11.0)
	S		.646 (16.4)			.315 (8.0)			.437 (11.1)		.244 (6.2)			
A	P	1.535 (39.0)		.988 (25.1)	1.311 (33.3)		.323 (8.2)	.488 (12.4)		.429 (10.9)		.232 (5.9)	1.091 (27.7)	.433 (11.0)
	S		.976 (24.8)			.315 (8.0)			.437 (11.1)		.244 (6.2)			
B	P	2.083 (52.9)		1.528 (38.8)	1.850 (47.0)		.323 (8.2)	.488 (12.4)		.433 (11.0)		.228 (5.8)	1.630 (41.4)	.433 (11.0)
	S		1.513 (38.5)			.315 (8.0)			.437 (11.1)		.244 (6.2)			
C	P	2.724 (69.2)		2.177 (55.3)	2.500 (63.5)		.323 (8.2)	.488 (12.4)		.433 (11.0)		.228 (5.8)	2.280 (57.9)	.433 (11.0)
	S		2.161 (54.9)			.315 (8.0)			.437 (11.1)		.244 (6.2)			
D	P	2.630 (66.8)		2.075 (52.7)	2.406 (61.1)		.433 (11.0)	.598 (15.2)		.433 (11.0)		.228 (5.8)	2.185 (55.5)	.543 (13.8)
	S		2.067 (52.5)			.429 (10.9)			.437 (11.1)		.244 (6.2)			

Panel Cutouts

Optimal cutout for rear mounting

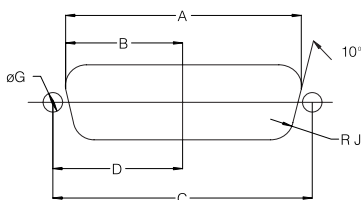

Standard cutout

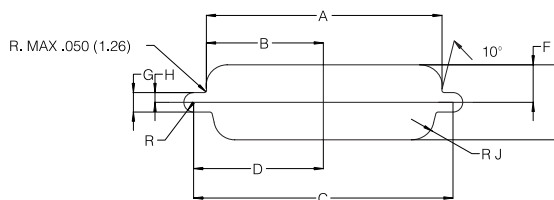

Shell Size	Mounting Method	A ±.008 (±0.20)	B ±.008 (±0.20)	C ±.008 (±0.20)	D ±.008 (±0.20)	E ±.008 (±0.20)	F ±.008 (±0.20)	G ±.008 (±0.20)	H ±.008 (±0.20)	J ±.008 (±0.20)
E	Front	.874 (22.2)	.437 (11.1)	.984 (25.0)	.492 (12.5)	.512 (13.0)	.256 (6.5)	.118 (3.0)	.059 (1.5)	.083 (2.1)
	Rear	.807 (20.5)	.402 (10.2)			.449 (11.4)	.224 (5.7)			.134 (3.4)
A	Front	1.201 (30.5)	.602 (15.3)	1.311 (33.3)	.657 (16.7)	.512 (13.0)	.256 (6.5)	.118 (3.0)	.059 (1.5)	.083 (2.1)
	Rear	1.134 (28.8)	.567 (14.4)			.449 (11.4)	.224 (5.7)			.134 (3.4)
B	Front	1.744 (44.3)	.870 (22.1)	1.850 (47.0)	.925 (23.5)	.512 (13.0)	.256 (6.5)	.118 (3.0)	.059 (1.5)	.083 (2.1)
	Rear	1.673 (42.5)	.839 (21.3)			.449 (11.4)	.224 (5.7)			.134 (3.4)
C	Front	2.390 (60.7)	1.197 (30.4)	2.500 (63.5)	1.248 (31.7)	.512 (13.0)	.256 (6.5)	.118 (3.0)	.059 (1.5)	.083 (2.1)
	Rear	2.327 (59.1)	1.161 (29.5)			.449 (11.4)	.224 (5.7)			.134 (3.4)
D	Front	2.295 (58.3)	1.150 (29.2)	2.406 (61.1)	1.205 (30.6)	.622 (15.8)	.311 (7.9)	.118 (3.0)	.059 (1.5)	.083 (2.1)
	Rear	2.217 (56.3)	1.110 (28.2)			.555 (14.1)	.280 (7.1)			.134 (3.4)

INCHES (MM)

**DERATING CURVE FOR HIGH POWER CONTACTS (Size 8)  
CURRENT RATING AND OPERATING TEMPERATURE**

Tested according to C E 1512-3, test 5b

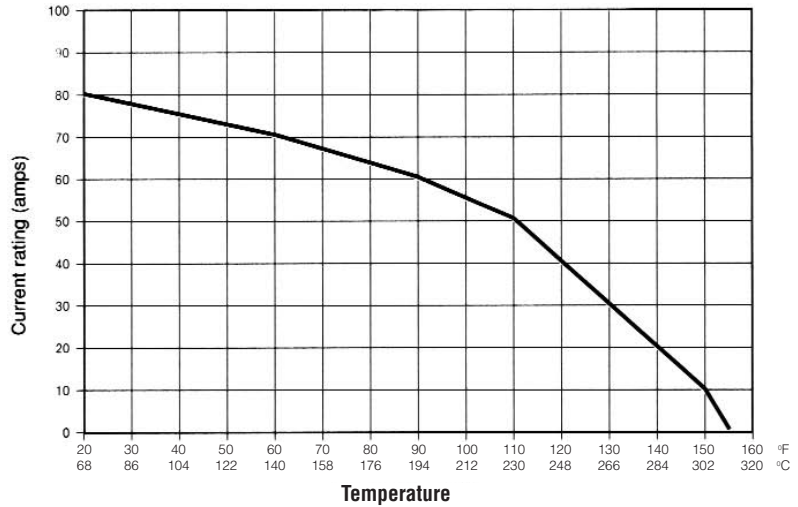

**DERATING CURVE FOR SIGNAL CONTACTS (Size 20)  
CURRENT RATING AND OPERATING TEMPERATURE**

Tested according to C E 1512-3, test 5b

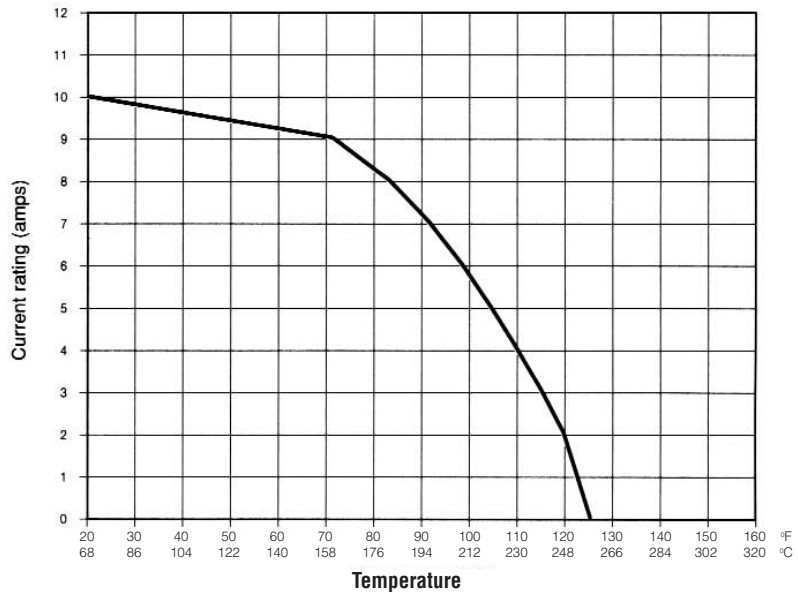

**WIRE RETENTION FORCE ON CRIMP CONTACTS**

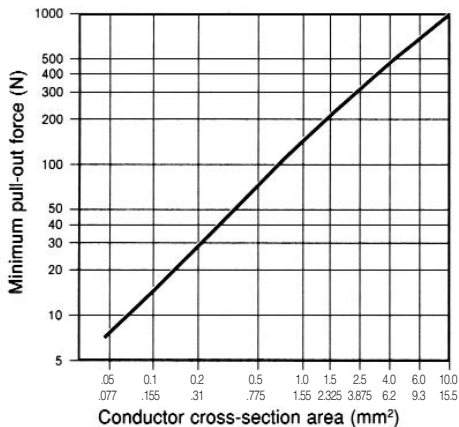

**BREAKDOWN VOLTAGE**

The following chart indicates the voltage rating (AC - Vrms - 50 Hz) and breakdown voltage for an operating temperature of 77°F (25°C) under 50% relative humidity.

Voltages are applied to male and female connectors mated or unmated.

Contact Types	Sea Level		19,685 (6,000 m)		68,898 (21,000 m)	
	Excitation	Test	Excitation	Test	Excitation	Test
Coax	1300 V	900 V	900 V	600 V	400 V	300 V
Power	1500 V	1000 V	1000 V	600 V	500 V	300 V
Voltage	3800 V	2800 V	2300 V	1700 V	650 V	450 V

## Digital Video Interface

### SPECIFICATIONS

#### MATERIALS

<b>Shell</b>	Zinc Alloy #3, Finish: 100µ"(2.54µm) min. of nickel
<b>Boardlock</b>	SPCC, 100µ"(2.54µm) min. of tin/lead
<b>Insulator</b>	P.B.T., 30% glass-filled, UL94V-0 rated
<b>Hex Screwlock</b>	Brass, 50µ"(1.27µm) min. of nickel
<b>Contact</b>	Phosphor bronze C521 OR-H per QQ-B-750
<b>Mating Area</b>	Selective gold, including gold flash, 10µ"(0.25µm) of gold, 15µ"(0.4µm) of gold and 30µ"(0.76µm) of gold
<b>Termination Area</b>	100µ"(2.54µm) min. of tin-lead
<b>Underplate</b>	50µ"(1.27µm) min. nickel
<b>Ground Blade</b>	Phosphor bronze C5191 R-H

#### MECHANICAL SPECIFICATION

##### Mating and Unmating Force

Mating force	9.92 lb. (4.5 kg.) per connector maximum
Unmating force	2.20 lb. (1 kg.) minimum, 8.82 lb. (4 kg.) maximum per connector

##### Mechanical Shock

Condition	EIA-364-27, condition A. (Specified pulse). No discontinuity at 1µs or longer (each contact) when continuity is tested per EIA-364-46.
-----------	---

##### Durability

Condition	EIA-364-09, mated and unmated connectors for 100 cycles at a rate of 100 +/-50 cycles per hour. There shall be no physical damage and shall meet requirements of subsequent tests.
-----------	--

## CONNECTORS

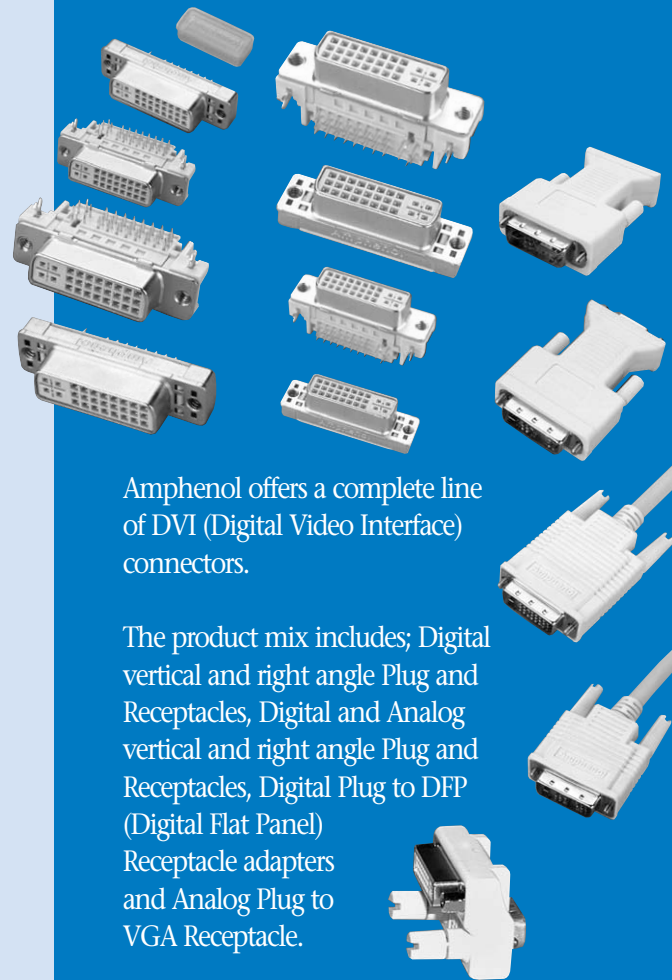

Amphenol offers a complete line of DVI (Digital Video Interface) connectors.

The product mix includes; Digital vertical and right angle Plug and Receptacles, Digital and Analog vertical and right angle Plug and Receptacles, Digital Plug to DFP (Digital Flat Panel) Receptacle adapters and Analog Plug to VGA Receptacle.

### G12 - X - X - X - X - X - X

#### DVI Connectors

Digital Video Interface, PCB Mount & Receptacle

#### Connector Style

A: Right Angle PCB Mount B: Straight PCB Mount

#### Signal Interface Option

1: Analog & Digital 2: Digital only

#### Contact Finish

0: Gold Flash 2: 20µ" (0.51µm) Gold  
1: 10µ" (0.25µm) Gold 3: 30µ" (0.76µm) Gold

#### Variation Code

Blank: Standard

#### Flange Mount Options

0: Without Hex Screwlock  
1: With #4-40UNC Hex Screwlock Bulk-packed  
2: With #4-40UNC Hex Screwlock Installed

#### Board Mount Option

1: Arrowhead Boardlock (For Straight PCB Mount Versions only)  
2: Grounding Posts and Locators  
3: Arrowhead Boardlock (ø 0.075" (1.93) and locators  
4: Arrowhead Boardlock (ø 0.124" (3.17) and locators

### G12C - X - X - X - X

#### DVI Connectors

Digital Video Interface, Cable Mount Plug

#### Signal Interface Option

1: Analog & Digital, 24 Position  
2: Analog & Digital, 18 Position  
3: Analog 12 Position  
4: Digital 24 Position  
5: Digital 18 Position

#### Variation Code

Blank: Standard  
1: With EMI shield Can (GT27C010)  
2: With EMI shield Can (GT27C010) Screw (GT127C008)

#### Front: Shell Finish

1: Nickel Plated 2: Tin Plated

#### Contact Finish

0: Gold Flash 2: 10µ" (0.25µm) Gold 4: 30µ" (0.76µm) Gold  
1: 5µ" (0.13µm) Gold 3: 20µ" (0.51µm) Gold

# SD308



For Sea, Air or Land, these connectors are SEALED! Amphenol's SD308 Sealed D-Subminiature Connectors are available in the full range of standard density and hi-density insert arrangements, pin and socket contacts. These connectors are supplied with fixed screw machine contacts and are available in Solder Cup, Straight PCB, and Right Angle PCB terminations.

- Ruggedized Computers and Peripheral Equipment
- Industrial Controllers
- 21st Century Soldier
- Ideal For Retrofit Applications Or Late Design-In

# Sealed D-Sub Connectors

## SPECIFICATIONS:

### PRODUCT FEATURES

- One piece machined Aluminum Shell
- Gold Plated Screw Machine Contacts
- Hi Grade Thermoplastic Inserts -67°F to +257°F (-55°C to +125°C)
- Integrated Blind Panel Mounts
- Supplied with Conductive Panel Seal Gasket

### MATERIALS AND PLATINGS

<b>Shells</b>	Machined aluminum alloy, tin plated
<b>Inserts</b>	High temperature resistant polyethersulfone per mil-p-46185
<b>Contacts</b>	Copper alloy, 20µ" (0.51µm) gold plated over nickel.
<b>Seal</b>	Silicone elastomer with nickel plated graphite flake

### ELECTRICAL DATA

<b>Current Rating</b>	5A
<b>Insulation Resistance</b>	5 GIGOHM @ 500 VDC
<b>Working Voltage</b>	120 VAC
<b>D.W.V.</b>	1,000 VAC pin to pin & pin to shell

### CLIMATIC DATA

<b>Operating Temperature</b>	-67°F to +257°F (-55°C to +125°C)
------------------------------	-----------------------------------

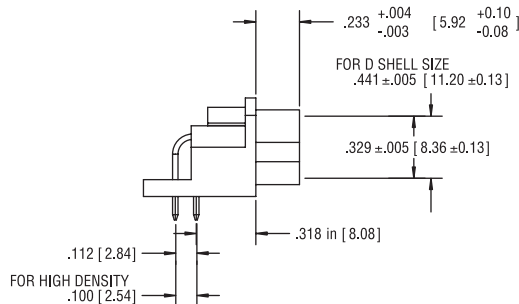

PLUG - SIDE VIEW

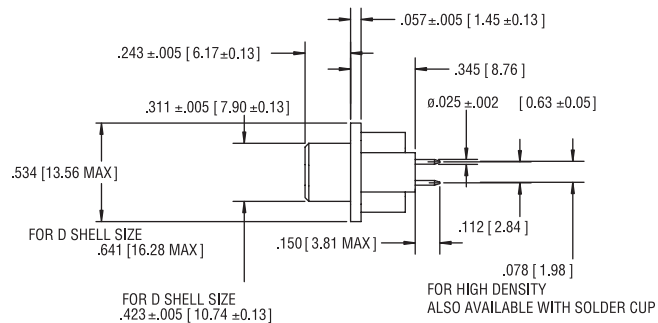

RECEPTACLE - SIDE VIEW

## SD308 - E09 - S - A - 1 - 000

**Series Designation**

**Shell Size & Number Of Contacts**

STD Density E09, A15, B25, C37, D50  
HIGH Density E15, A26, B44, C62, D78, 6106

**Contact Type**

S=Socket Contact P= Pin Contact

000 = Standard part  
other deviations as required

**Mounting Type**

1 = 4-40 Blind Nut  
2 = 4-40 Blind Nut with R/A Mounting Bracket

**Termination Style**

A = Right Angle pcb B = Vertical pcb  
C = Solder Cup

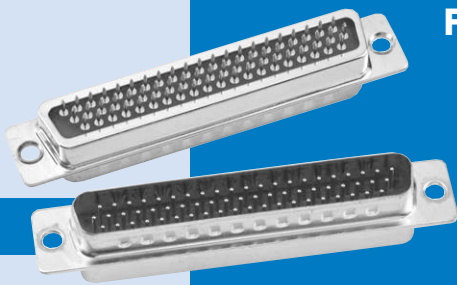

**SPECIFICATIONS:**

**DESCRIPTION**

- Hi reliability filtering in multi row arrangements
- Stamped and Formed shells
- Screw Machine Contacts and Hi Reliability inserts
- Available in all Hi-Density insert patterns

**MATERIALS AND PLATINGS**

<b>Shells</b>	Stamped steel shell, tin plated
<b>Inserts</b>	High temperature resistant polyethersulfone per MIL-P-46185
<b>Contacts</b>	Machined copper alloy, 20µ" (0.51µm) gold plated over nickel
<b>Capacitor</b>	Barium titanate ceramic array

**ELECTRICAL DATA**

<b>Current Rating</b>	5 A
<b>Insulation Resistance</b>	5 GIGOHM @ 500 VDC
<b>Working Voltage</b>	200 VDC
<b>D.W.V.</b>	500 VDC pin to pin & pin to shell
<b>Capacitance</b>	+/- 20% ( see P/N description )

**CLIMATIC DATA**

**Operating Temperature** -67°F to +257°F (-55°C to +125°C)

For 50 position and all high density versions. Amphenol's FD308 Filtered D-Subminiature connectors are available in the full range of hi-density insert arrangements, pin and socket contacts, plus the 50 position standard density. These connectors are supplied with fixed screw machine contacts and are available in Straight and Right Angle PCB terminations and Solder Cup.

- Computers and Peripheral Equipment
- Avionics Systems Ideal For Retrofit Applications Or Late Design-In

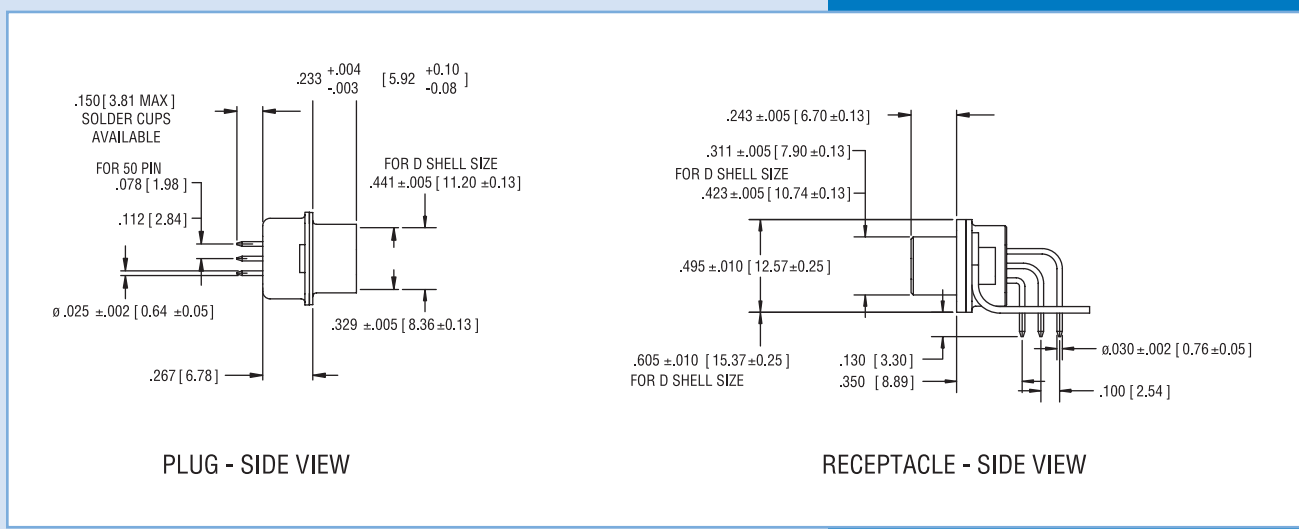

**FD308 - B44 - S - A - 1 - A2 - 000**

<b>Series Designation</b>	FD308	<b>000</b> = Standard part other deviations as required
<b>Size &amp; Number Of Contacts</b>	B44 STD Density E09, A15, B25, C37, D50 High Density E15, A26, B44, C62, D78, 6104	<b>Capacitance Code</b> A2 = 200 PF      02 = 2000 PF A4 = 400 PF      05 = 5000 PF 01 = 1000 PF
<b>Contact Type</b>	S = Socket Contact    P = Pin Contact	<b>Mounting Type</b> 1 = 4-40 Clinch Nut 2 = Ø.120 (3.05) Hole 3 = R/A Mounting Bracket 4 = 4-40 Clinch Nut with R/A Mounting Bracket
<b>Termination Style</b>	A = Right Angle pcb B = Vertical pcb C = Solder Cup	

**ORDERING INFORMATION - IDC**

**FCC17 - E09 - S - W - 4 - 8 - 0 - G**

**Series Designation**

**Size and Configuration**

15 & 25 Size Consult Factory.

**Connector Type**

S: Socket P: Pin Consult Factory.

**Termination Type**

W: IDC \*

**Mounting**

2: .120 (3.05) Diameter Through Hole  
4: 4-40 Threaded Inserts  
6: M3 Threaded Inserts

**Special**

G: 50 Micro Inches Gold

**Modifier**

0: Standard Product  
x: Special or Custom Versions

**Capacitance Value**

D: 50 pF	5: 1,000 pF
0: 180 pF	E: 2,200 pF
F: 330 pF	9: 5,600 pF
1: 470 pF	8: 47,000 pF
4: 820 pF	

Other Capacitance values available.  
Consult Factory.

**ORDERING INFORMATION - FILTERED PRESS FIT**

**FCC17 - B25 - S - R - 4 - 8 - 0 - G**

**Series Designation**

**Size and Configuration \***

**Connector Type**

S: Socket P: Pin Consult Factory.

**Termination Type**

R: Press Fit

**Mounting**

2: .120 (3.05) Diameter Through Hole	5: 4-40 Threaded Standoff
3: 4-40 Self Locking Threaded Insert	6: M3 Threaded Inserts
4: 4-40 Threaded Inserts	E: Code 4 with 4-40 Hex Jack Socket

**Special**

G: 50 Micro Inches Gold

**Modifier**

0: Standard Product  
x: Special or Custom Versions

**Capacitance Value**

D: 50 pF	5: 1,000 pF
0: 180 pF	E: 2,200 pF
F: 330 pF	9: 5,600 pF
1: 470 pF	8: 47,000 pF
4: 820 pF	

Other Capacitance values available.  
Consult Factory.

**ORDERING INFORMATION - STACKED D-SUB**

**FCC17 - 2 - BP - BS - 4 - 5 - 5 - X**

**Series Designation**

**Vertical Mounting Dimension Between Connectors**

1 = .625 (15.88)  
2 = .750 (19.05)

**Upper Connector Configuration (Size and Style)**

EP: 9 pin	BP: 25 pin
ES: 9 socket	BS: 25 socket
AP: 15 pin	CP: 37 pin
AS: 15 socket	CS: 37 socket

**Lower Connector Configuration**

(Size and Style) same as Upper Connector Configuration

**Mounting**

2: .120 (3.05) Diameter Through Hole on Flanges  
4: 4-40 Threaded Inserts on Flanges  
E: 4-40 Hex Jack Sockets (supplied loose)

**Modifier**

0: Standard Product  
x: Special or Custom Versions

**Lower Connector Filter Capacitance**  
same as Upper Connector Filter Capacitance Designation

**Upper Connector Filter Capacitance**

D: 50 pF	5: 1,000 pF
0: 180 pF	E: 2,200 pF
F: 330 pF	7: 1,200 pF
1: 470 pF	9: 5,600 pF
4: 820 pF	8: 47,000 pF

\* For Additional Mounting Options and Filter Capacitance - Consult Factory

**ORDERING INFORMATION - D-SUB**

**FCC17 - B25 - S - C - 4 - 4 - 0 - G**

**Series Designation**

**Size**

E09, A15, B25, C37

**Connector type**

A - Adapter P - Pin S - Socket

**Termination Type**

A - Right Angle PC Tail, .318 (8.08) Footprint  
 B - Right Angle PC Tail, .405 (10.29) Footprint  
 C - Right Angle PC Tail, .590 (14.99) Footprint  
 D - Pin/Socket Adapter  
 E - Vertical Mount PC Tail  
 M - Solder Cup  
 N - Vertical Mount PC Tail - Long Body

**Mounting options\***

A: 4-40 Threaded PC Tail Standoffs with Boardlock, Vertical Mount Only  
 E: 4-40 Hex Jack Sockets (supplied loose)  
 F: 4-40 Round Fixed Jack Sockets  
 2: .120 (3.05) diameter Through hole  
 3: Self-Locking 4-40 Threaded Inserts  
 4: 4-40 Threaded Inserts (Standard)  
 5: 4-40 Threaded Stand-Offs, Vertical Mount  
 6: M3 Threaded inserts

\* For Additional Mounting Options and Filter Capacitance - Consult Factory

**Specials**

No Digit: Standard 15µ" (0.38µm) gold  
 G: 50µ" (1.27µm) gold  
 K: 30µ" (0.76µm) gold  
 L: Standard Connector with added ferrite block

**Modifier**

0 = Standard Product (Boardlocks on Right Angle D-Subs)  
 B = Metal Mounting Brackets, for Right Angle D-Subs  
 D = .315 (8.00) to Boardlock for .590 (14.99) footprint  
 E = Plastic Bracket - No Boardlock  
 F = No Boardlock, No plastic or metal Bracket - Alignment Strip Only  
 X = Specials or Custom Versions

**Filter Capacitance (pF)\***

D: 50 pF	5: 1,000 pF
B: 100 pF	7: 1,200 pF
0: 180 pF	E: 2,200 pF
F: 330 pF	9: 5,600 pF
1: 470 pF	8: 47,000 pF
4: 820 pF	

**ORDERING INFORMATION - COMBO D-SUB**

**FCC17 - A - 3W3 - P - M - 4 - 5 - 0 - G**

**Series Designation**

**Shell Size**

A, B, C, D, E

**Arrangement**

**Connector type**

A = Adapter, P = Pin, S = Socket

**Termination type**

D = Pin/Socket Adapter  
 E = Power PC Tail - 40A - .126 (3.20) Dia., .175 (4.44) Lg.  
 K = Power Solder Cup - 10A - Wire Size 16  
 L = Power Solder Cup - 20A - Wire Size 12  
 M = Power Solder Cup - 40A - Wire Size 8  
 R = Power Press Fit - 20A - .145 (3.68) Lg. - .126 (3.20) Dia. Hole

**Mounting Options**

2 = .120 (3.05) dia. mounting holes  
 3 = 4-40 Threads Self locking  
 4 = 4-40 Threads  
 5 = 4-40 Standoffs - PC tail only  
 6 = M3 Threads  
 E = 4-40 Hex Jack Sockets (supplied loose)

**Plating Option**

Blank = Standard 30µ" (0.76µm) gold  
 G = 50µ" (1.27µm) gold

**Modifier**

0 = Standard  
 X = Specials or Custom versions (Consult Factory)

**Filter Capacitance (pF)**

D: 50 pF	5: 1000 pF
B: 100 pF	7: 1200 pF
o: 180 pF	E: 2200 pF
f: 330 pF	9: 5600 pF
l: 470 pF	8: 47000 pF
4: 820 pF	

\* For Additional Mounting Options and Filter Capacitance - Consult Factory



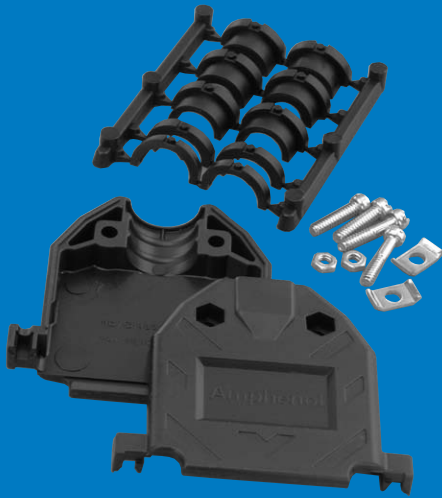

Amphenol's black plastic backshell accommodates most standard and high-density D-Subminiature connectors and is appropriate for most cable assemblies. This version is economical and highly durable. The split-grommet insert provides cable strain relief while making it easy to assemble.

**SPECIFICATIONS:**

**Housing Material:** Styrene (UL 94 VO)  
**Grommet Material:** Polypropylene  
**Mounting Hardware:** Steel, clear zinc finish

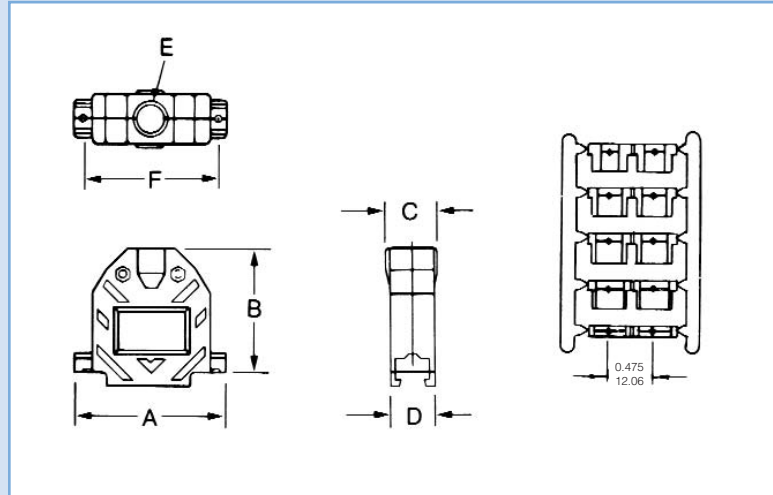

**DIMENSIONS AND ORDERING INFORMATION**

Shell Size	Standard # of Contacts	Hi-Density # of Contacts	Part #	Dimensions						Cable Diameter Range	
				A	B	C	D	E	F	Minimum	Maximum
E	9	15	17-1724-1	1.217 (30.91)	1.547 (39.29)	0.640 (16.26)	0.640 (16.26)	0.400 (10.16)	0.984 (24.99)	0.210 (5.33)	0.350 (8.89)
A	15	26	17-1725-1	1.545 (39.24)	1.505 (38.23)	0.640 (16.26)	0.640 (16.26)	0.400 (10.16)	1.312 (33.32)	0.210 (5.33)	0.350 (8.89)
B	25	44	17-1726-1	2.090 (53.08)	1.655 (42.04)	0.710 (18.03)	0.640 (16.26)	0.522 (13.26)	1.857 (47.17)	0.230 (5.84)	0.450 (11.43)
C	37	62	17-1727-1	2.734 (69.44)	1.830 (46.48)	0.906 (23.01)	0.640 (16.26)	0.726 (18.44)	2.500 (63.50)	0.350 (8.89)	0.640 (16.26)
D	50	78	17-1728-1	2.645 (67.18)	1.855 (47.12)	0.940 (23.88)	0.770 (19.56)	0.726 (18.44)	2.406 (61.11)	0.350 (8.89)	0.640 (16.26)



## Plated Plastic Backshell

### SPECIFICATIONS:

<b>Housing Material:</b>	ABS Polymer
<b>Plating:</b>	Nickel over copper
<b>Grommet Material:</b>	PVC (UL 94 VO)
<b>Mounting Hardware:</b>	Steel, clear zinc finish

### ASSEMBLY INSTRUCTIONS

1. Select the tightest insert that will fit over the cable and thread the cable through it, placing the end with the smaller O.D. (the end without the washer) towards the connector.
2. Cut the jacket, fold the shielding back over the outside of the insert and cut it just short of the washer.
3. Install jackscrews and connector.
4. Place the washer in the outermost depression in the exit area of the hood and screw the cover closed.

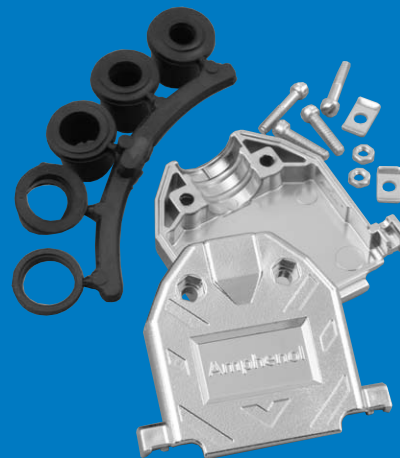

Amphenol's plated plastic backshell accommodates most standard and high-density D-Subminiature connectors and is appropriate for cable assemblies requiring compliance to FCC 20780. This version is highly durable and provides EMI/RFI protection. The rubber grommet compression insert forces the cable's shielding against the inside of the cable exit area, assuring shielding.

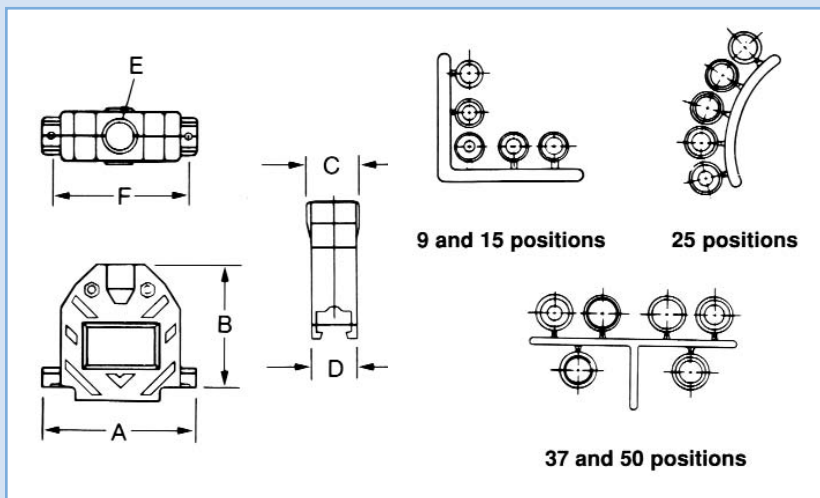

### DIMENSIONS AND ORDERING INFORMATION

Shell Size	Standard # of Contacts	Hi-Density # of Contacts	Part #	Dimensions						Cable Diameter Range	
				A	B	C	D	E	F	Minimum	Maximum
E	9	15	17-1724-2	1.217 (30.91)	1.547 (39.29)	0.640 (16.26)	0.640 (16.26)	0.400 (10.16)	0.984 (24.99)	0.210 (5.33)	0.320 (8.13)
A	15	26	17-1725-2	1.545 (39.24)	1.505 (38.23)	0.640 (16.26)	0.640 (16.26)	0.400 (10.16)	1.312 (33.32)	0.210 (5.33)	0.320 (8.13)
B	25	44	17-1726-2	2.000 (50.8)	1.655 (42.04)	0.710 (18.03)	0.640 (16.26)	0.522 (13.26)	1.857 (47.17)	0.230 (5.84)	0.450 (11.43)
C	37	62	17-1727-2	2.730 (69.34)	1.830 (46.48)	0.906 (23.01)	0.640 (16.26)	0.726 (18.44)	2.500 (63.50)	0.350 (8.89)	0.650 (16.51)
D	50	78	17-1728-2	2.645 (67.18)	1.855 (47.12)	0.940 (23.88)	0.440 (11.18)	0.726 (18.44)	2.406 (61.11)	0.350 (8.89)	0.650 (16.51)

INCHES (MM)

## ACCESSORIES

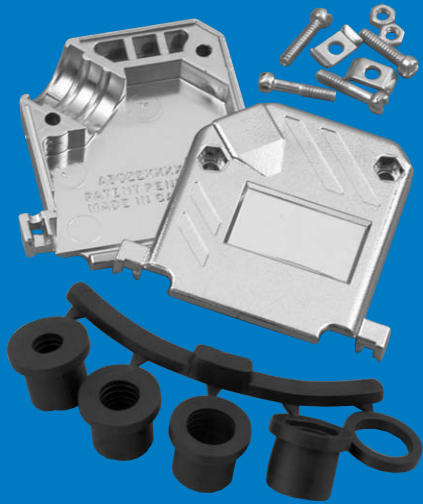

Amphenol's plated plastic backshell accommodates most standard and high-density D-Subminiature connectors and is appropriate for cable assemblies requiring compliance to FCC 20780. This version is highly durable and provides EMI/RFI protection. The rubber grommet compression insert forces the cable's shielding against the inside of the cable exit area, assuring shielding. The 45° cable exit helps save space behind equipment.

## 45° Plated Plastic Backshell

### SPECIFICATIONS:

<b>Housing Material:</b>	ABS Polymer
<b>Plating:</b>	Nickel over copper
<b>Grommet Material:</b>	PVC (UL 94 VO)
<b>Mounting Hardware:</b>	Steel, clear zinc finish

### ASSEMBLY INSTRUCTIONS

1. Select the tightest insert that will fit over the cable and thread the cable through it, placing the end with the smaller O.D. (the end without the washer) towards the connector.
2. Cut the jacket, fold the shielding back over the outside of the insert and cut it just short of the washer.
3. Install jackscrews and connector.
4. Place the washer in the outermost depression in the exit area of the hood and screw the cover closed.

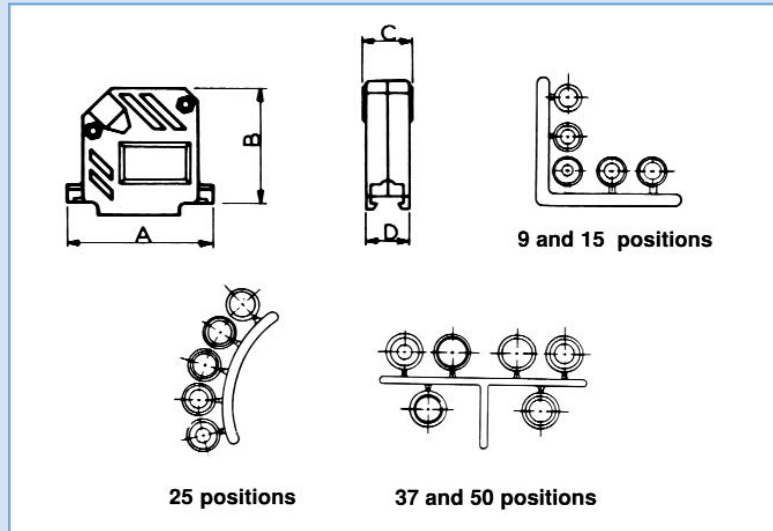

### DIMENSIONS AND ORDERING INFORMATION

Shell Size	Standard # of Contacts	Hi-Density # of Contacts	Part #	Dimensions						Cable Diameter Range	
				A	B	C	D	E	F	Minimum	Maximum
E	9	15	17-1824-2	1.217 (30.91)	1.430 (36.32)	0.640 (16.26)	0.640 (16.26)	0.400 (10.16)	0.984 (24.99)	0.210 (5.33)	0.320 (8.13)
A	15	26	17-1825-2	1.545 (39.24)	1.568 (39.83)	0.640 (16.26)	0.640 (16.26)	0.400 (10.16)	1.312 (33.32)	0.210 (5.33)	0.320 (8.13)
B	25	44	17-1826-2	2.090 (53.09)	1.735 (44.07)	0.710 (18.03)	0.640 (16.26)	0.522 (13.26)	1.857 (47.17)	0.230 (5.84)	0.450 (11.43)
C	37	62	17-1827-2	2.734 (69.44)	1.976 (50.19)	0.906 (23.01)	0.640 (16.26)	0.726 (18.44)	2.500 (63.5)	0.350 (8.89)	0.650 (16.51)

## Two-Piece Die Cast Shielded Backshells

### SPECIFICATIONS:

Housing Material:	Die cast zinc
Grommet Material:	PVC (UL 94 VO)
Mounting Hardware:	Steel, clear zinc finish

### ASSEMBLY INSTRUCTIONS

1. Select the tightest insert that will fit over the cable and thread the cable through it, placing the end with the smaller O.D. (the end without the washer) towards the connector.
2. Cut the jacket, fold the shielding back over the outside of the insert and cut it just short of the washer.
3. Install jackscrews and connector.
4. Place the washer in the outermost depression in the exit area of the hood and screw the cover closed.

#### 9 and 15 positions

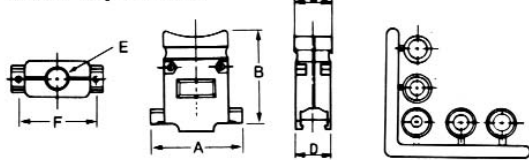

#### 25 positions

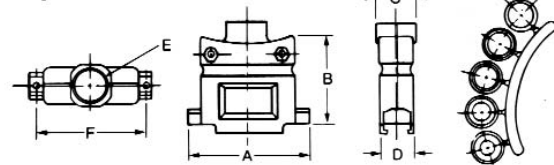

#### 37 and 50 positions

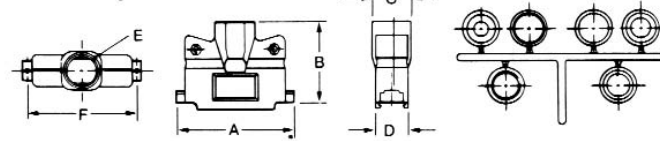

## ACCESSORIES

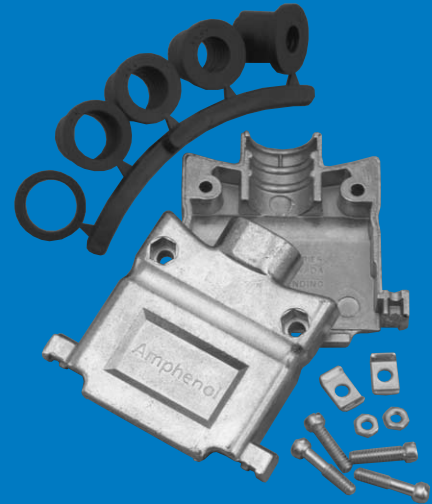

Amphenol's metal backshell accommodates most standard and high-density D-Subminiature connectors and is appropriate for cable assemblies requiring compliance to FCC 20780. This version is highly durable and provides EMI/RFI protection. The rubber grommet compression insert forces the cable's shielding against the inside of the cable exit area, assuring shielding.

### DIMENSIONS AND ORDERING INFORMATION

Shell Size	Standard # of Contacts	Hi-Density # of Contacts	Part #	Dimensions						Cable Diameter Range	
				A	B	C	D	E	F	Minimum	Maximum
E	9	15	17-1657-09	1.217 (30.91)	1.430 (36.32)	0.640 (16.26)	0.640 (16.26)	0.400 (10.16)	0.984 (24.99)	0.210 (5.33)	0.320 (8.13)
A	15	26	17-1657-15	1.545 (39.24)	1.568 (39.83)	0.640 (16.26)	0.640 (16.26)	0.400 (10.16)	1.312 (33.32)	0.210 (5.33)	0.320 (8.13)
B	25	44	17-1657-25	2.090 (53.09)	1.735 (44.07)	0.710 (18.03)	0.640 (16.26)	0.522 (13.26)	1.857 (47.17)	0.230 (5.84)	0.450 (11.43)
C	37	62	17-1657-37	2.734 (69.44)	1.976 (50.19)	0.906 (23.01)	0.640 (16.26)	0.726 (18.44)	2.500 (63.5)	0.350 (8.89)	0.640 (16.26)

INCHES (MM)

## Данный компонент на территории Российской Федерации

### Вы можете приобрести в компании MosChip.

Для оперативного оформления запроса Вам необходимо перейти по данной ссылке:

<http://moschip.ru/get-element>

Вы можете разместить у нас заказ для любого Вашего проекта, будь то серийное производство или разработка единичного прибора.

В нашем ассортименте представлены ведущие мировые производители активных и пассивных электронных компонентов.

Нашей специализацией является поставка электронной компонентной базы двойного назначения, продукции таких производителей как XILINX, Intel (ex.ALTERA), Vicor, Microchip, Texas Instruments, Analog Devices, Mini-Circuits, Amphenol, Glenair.

Сотрудничество с глобальными дистрибьюторами электронных компонентов, предоставляет возможность заказывать и получать с международных складов практически любой перечень компонентов в оптимальные для Вас сроки.

На всех этапах разработки и производства наши партнеры могут получить квалифицированную поддержку опытных инженеров.

Система менеджмента качества компании отвечает требованиям в соответствии с ГОСТ Р ИСО 9001, ГОСТ РВ 0015-002 и ЭС РД 009

### Офис по работе с юридическими лицами:

105318, г.Москва, ул.Щербаковская д.3, офис 1107, 1118, ДЦ «Щербаковский»

Телефон: +7 495 668-12-70 (многоканальный)

Факс: +7 495 668-12-70 (доб.304)

E-mail: [info@moschip.ru](mailto:info@moschip.ru)

Skype отдела продаж:

moschip.ru

moschip.ru\_4

moschip.ru\_6

moschip.ru\_9