

## 8bit 8ch D/A Converter

### ■ GENERAL DESCRIPTION

The NJW5211 is 8bit 8ch D/A converter for electronic adjustment. 8ch DC out put can be independently controlled by three-wire serial interface.

The NJW5211 features low operating voltage(2.7V) and can be full-swing outputted regardless of supply voltage.

The small package(SSOP14) is suitable for portable applications.

### ■ PACKAGE OUTLINE



NJW5211V

### ■ FEATURES

- Low Operating Voltage      2.7 to 5.5V
- 8bit 8ch D/A Converters Adopting R-2R System
- 3-wire 11-bit Serial Interface
- Internal POWER ON RESET Circuit
- Bi-CMOS Technology
- Package Outline            SSOP14

### ■ BLOCK DIAGRAM and PIN DIAGRAM

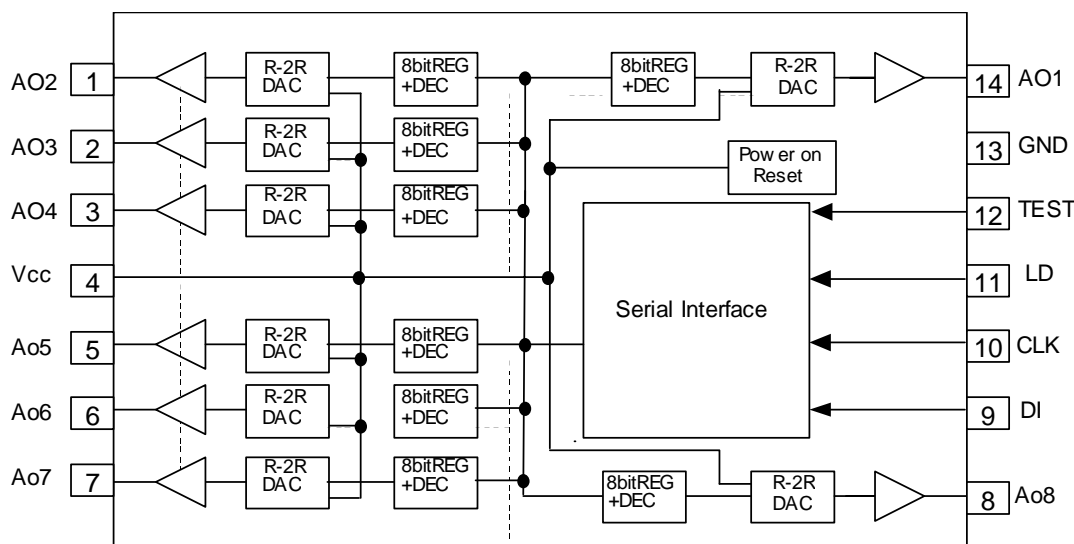

Pin No.	Pin Name	IN/OUT	Description
1	AO2	OUT	Analog Output
2	AO3	OUT	Analog Output
3	AO4	OUT	Analog Output
4	Vcc	-	Vcc
5	AO5	OUT	Analog Output
6	AO6	OUT	Analog Output
7	AO7	OUT	Analog Output
8	AO8	OUT	Analog Output
9	D1	IN	Serial Data Input
10	CLK	IN	Serial CLK Input
11	LD	IN	Serial Load Input
12	TEST	-	TEST Terminal
13	GND	-	GND
14	AO1	OUT	Analog Output

# NJW5211

## ■ ABOSOLUTE MAXIMUM RATINGS (Ta=25°C)

PARAMETER	SYMBOL	RATING	UNIT
Supply Voltage	V <sup>+</sup>	-0.3 to 7.0	V
Terminal Voltage	V <sub>in</sub>	-0.3 to V <sup>+</sup>	V
Power Dissipation	P <sub>D</sub>	300	mW
Operating Temperature Range	T <sub>opr</sub>	-40 to +85	°C
Storage Temperature Range	T <sub>stg</sub>	-40 to +150	°C

## ■ RECOMMENDED OPERATING CONDITION (Ta=25°C)

PARAMETER	SYMBOL	TEST CONDITION	MIN.	TYP.	MAX.	UNIT
Operating Voltage	V <sub>opr</sub>		2.7	-	5.5	V
Analog Output Source Current	I <sub>OL</sub>		-	-	1.0	mA
Analog Output Sink Current	I <sub>OH</sub>		-	-	1.0	mA
Serial Clock Frequency	FSCLK		-	1.0	-	MHz
Limit Road Capacitance	CL		-	-	0.1	μF

## ■ ELECTRICAL CHARACTERISTICS (V<sup>+</sup>=3.0V, Ta=25°C)

PARAMETER	SYMBOL	TEST CONDITION	MIN.	TYP.	MAX.	UNIT
Operating Current	I <sub>CC</sub>	CLK=1MHz 80H set	-	0.75	1.5	mA
<Logic Interface>						
Input low voltage	V <sub>IL</sub>		0	-	0.3	V
Input high voltage	V <sub>IH</sub>		1.8	-	V <sup>+</sup>	V
Input low current	I <sub>IL</sub>		-	-	10	μA
Input high current	I <sub>IH</sub>		-	-	10	μA
<Buffer Amplifier>						
Minimum output voltage	ZS1	00H set IOH=0.0mA	0	-	0.1	V
	ZS2	00H set IOH=0.5mA	0	-	0.2	
	ZS3	00H set IOH=1.0mA	0	-	0.3	
Maximum output voltage	FS1	FFH set IOL=0.0mA	V <sup>+</sup> -0.1	-	V <sup>+</sup>	V
	FS2	FFH set IOL=0.5mA	V <sup>+</sup> -0.2	-	V <sup>+</sup>	
	FS3	FFH set IOL=1.0mA	V <sup>+</sup> -0.3	-	V <sup>+</sup>	
<DAC accuracy>						
Resolution	RES		-	8	-	bit
Difference non-linearity error	DNL	Input code 02H to FDH	-1.0	-	1.0	LSB
Integral non-linearity error	INL	Input code 02H to FDH	-1.5	-	1.5	LSB

## ■ POWER ON RESET

PARAMETER	SYMBOL	TEST CONDITION	MIN.	TYP.	MAX.	UNIT
V <sup>+</sup> supply voltage rise time	trV <sub>CC</sub>	V <sup>+</sup> =0→2.7V	10	-	-	ms
Power on reset voltage	VPOR		-	1.9	-	V

## ■ Condition of operating timing

PARAMETER	SYMBOL	TEST CONDITION	MIN.	TYP.	MAX.	UNIT
CLK L level pulse width	tCLKL		200	-	-	ns
CLK H level pulse width	tCLKH		200	-	-	ns
DI setup time	tSDI		30	-	-	ns
DI hold time	tHDI		60	-	-	ns
LD setup time	tSLD		200	-	-	ns
LD hold time	tHLD		100	-	-	ns
LD "H" level pulse width	tLDH		100	-	-	ns
Analog output delay time voltage	tOUT	CL=50pF, RL=10kΩ	-	-	300	μs

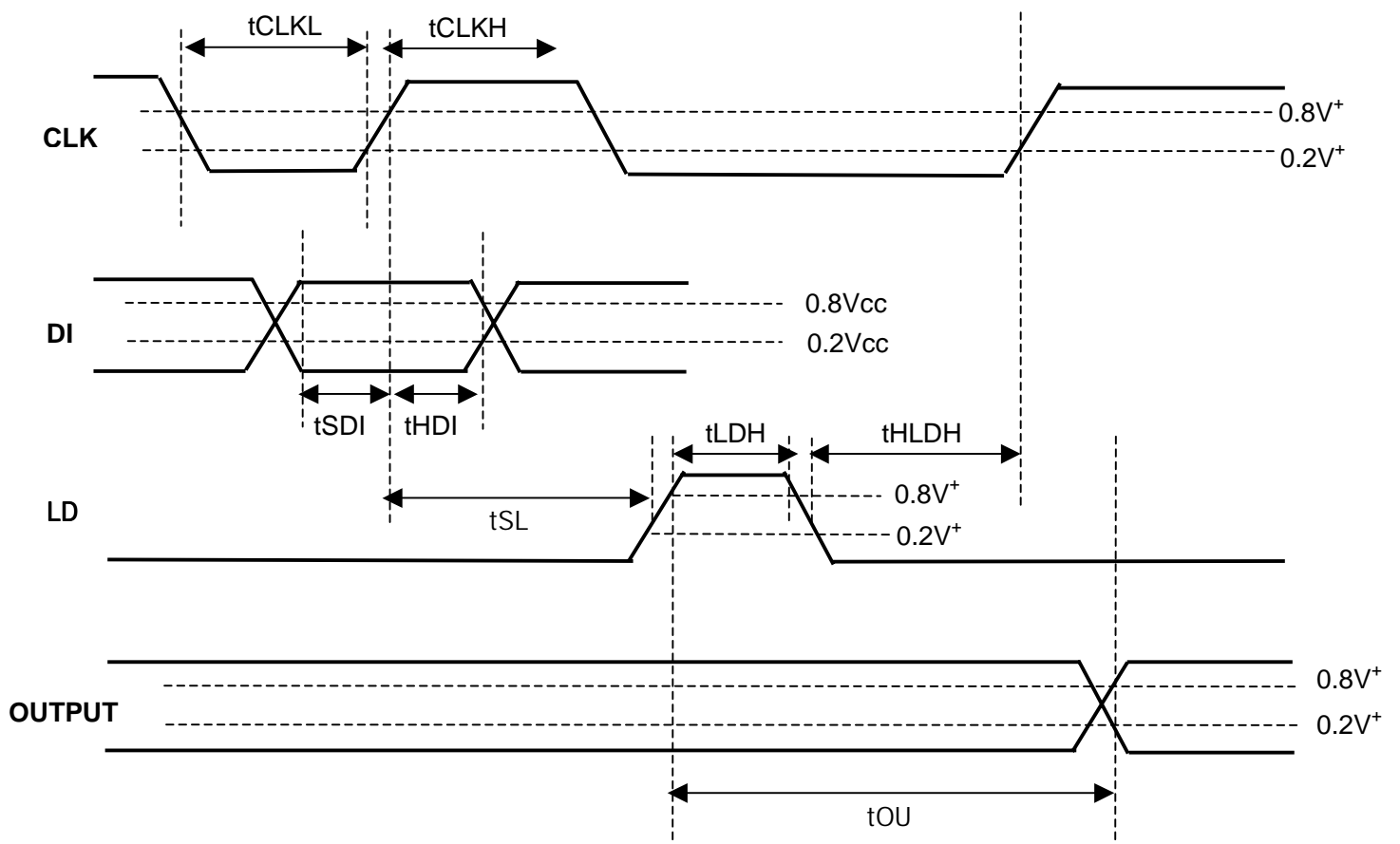

\*A signal level is judged at 80% or 20% of V<sup>+</sup>

# NJW5211

## ■Command sending

Control command is 3wire 10bit serial interface.(MSB first)

Data is taken in with rise edge on the CLK and output data is fixed in the LD high section.

Data is maintained in the LD low section.

LSB(LAST)

MSB(FIRST)

Data set								Channel select		
D0	D1	D2	D3	D4	D5	D6	D7	D8	D9	D10

Data Set

D0	D1	D2	D3	D4	D5	D6	D7	Analog output voltage level
0	0	0	0	0	0	0	0	GND
1	0	0	0	0	0	0	0	(V <sup>+</sup> -GND)/256x1
0	1	0	0	0	0	0	0	(V <sup>+</sup> -GND)/256x2
1	1	0	0	0	0	0	0	(V <sup>+</sup> -GND)/256x3
0	0	1	0	0	0	0	0	(V <sup>+</sup> -GND)/256x4
:	:	:	:	:	:	:	:	:
0	1	1	1	1	1	1	1	(V <sup>+</sup> -GND)/256x254
1	1	1	1	1	1	1	1	(V <sup>+</sup> -GND)/256x255

Channel select

D8	D9	D10	Address select
0	0	0	AO1
1	0	0	AO2
0	1	0	AO3
1	1	0	AO4
0	0	1	AO5
1	0	1	AO6
0	1	1	AO7
1	1	1	AO8

**[CAUTION]**

The specifications on this databook are only given for information, without any guarantee as regards either mistakes or omissions. The application circuits in this databook are described only to show representative usages of the product and not intended for the guarantee or permission of any right including the industrial rights.

# Mouser Electronics

Authorized Distributor

Click to View Pricing, Inventory, Delivery & Lifecycle Information:

[NJR:](#)

[NJW5211RB1-TE1](#) [NJW5211V-TE1](#)

## Данный компонент на территории Российской Федерации

### Вы можете приобрести в компании MosChip.

Для оперативного оформления запроса Вам необходимо перейти по данной ссылке:

<http://moschip.ru/get-element>

Вы можете разместить у нас заказ для любого Вашего проекта, будь то серийное производство или разработка единичного прибора.

В нашем ассортименте представлены ведущие мировые производители активных и пассивных электронных компонентов.

Нашей специализацией является поставка электронной компонентной базы двойного назначения, продукции таких производителей как XILINX, Intel (ex.ALTERA), Vicor, Microchip, Texas Instruments, Analog Devices, Mini-Circuits, Amphenol, Glenair.

Сотрудничество с глобальными дистрибьюторами электронных компонентов, предоставляет возможность заказывать и получать с международных складов практически любой перечень компонентов в оптимальные для Вас сроки.

На всех этапах разработки и производства наши партнеры могут получить квалифицированную поддержку опытных инженеров.

Система менеджмента качества компании отвечает требованиям в соответствии с ГОСТ Р ИСО 9001, ГОСТ РВ 0015-002 и ЭС РД 009

### Офис по работе с юридическими лицами:

105318, г.Москва, ул.Щербаковская д.3, офис 1107, 1118, ДЦ «Щербаковский»

Телефон: +7 495 668-12-70 (многоканальный)

Факс: +7 495 668-12-70 (доб.304)

E-mail: [info@moschip.ru](mailto:info@moschip.ru)

Skype отдела продаж:

moschip.ru

moschip.ru\_4

moschip.ru\_6

moschip.ru\_9