

RF Power Field Effect Transistors

N-Channel Enhancement-Mode Lateral MOSFETs

RF power transistors designed for applications operating at frequencies from 900 to 1215 MHz. These devices are suitable for use in defense and commercial pulse applications, such as IFF and DME.

- Typical Pulse Performance: $V_{DD} = 50$ Vdc, $I_{DQ} = 150$ mA, $P_{out} = 1000$ W Peak (100 W Avg.), $f = 1030$ MHz, Pulse Width = 128 μ sec, Duty Cycle = 10%
 Power Gain — 20 dB
 Drain Efficiency — 56%
- Capable of Handling 5:1 VSWR, @ 50 Vdc, 1030 MHz, 1000 W Peak Power

Features

- Characterized with Series Equivalent Large-Signal Impedance Parameters
- Internally Matched for Ease of Use
- Qualified Up to a Maximum of 50 V_{DD} Operation
- Integrated ESD Protection
- Designed for Push-Pull Operation
- Greater Negative Gate-Source Voltage Range for Improved Class C Operation
- In Tape and Reel. R5 Suffix = 50 Units, 56 mm Tape Width, 13-inch Reel.

MMRF1007HR5
MMRF1007HSR5

965-1215 MHz, 1000 W, 50 V
LATERAL N-CHANNEL
BROADBAND
RF POWER MOSFETs

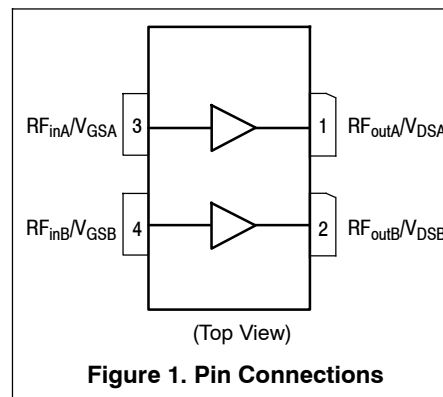
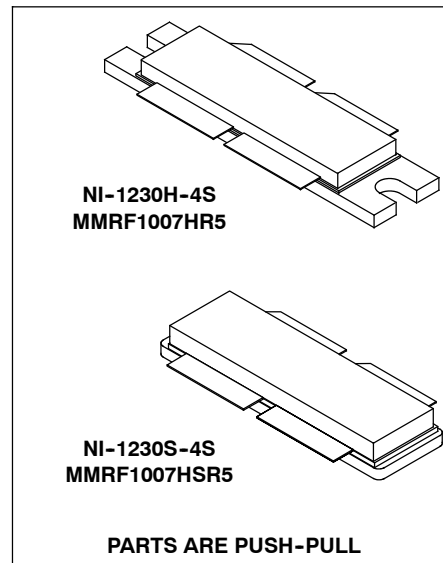

Table 1. Maximum Ratings

Rating	Symbol	Value	Unit
Drain-Source Voltage	V_{DSS}	-0.5, +110	Vdc
Gate-Source Voltage	V_{GS}	-6.0, +10	Vdc
Storage Temperature Range	T_{stg}	-65 to +150	$^{\circ}$ C
Case Operating Temperature	T_C	150	$^{\circ}$ C
Operating Junction Temperature (1)	T_J	225	$^{\circ}$ C

1. Continuous use at maximum temperature will affect MTF.

Table 2. Thermal Characteristics

Characteristic	Symbol	Value ⁽¹⁾	Unit
Thermal Resistance, Junction to Case Case Temperature 67°C, 1000 W Peak, 128 μsec Pulse Width, 10% Duty Cycle, 50 Vdc, I _{DQ} = 150 mA	Z _{θJC}	0.02	°C/W
Case Temperature 62°C, Mode-S Pulse Train, 80 Pulses of 32 μsec On, 18 μsec Off, Repeated Every 40 msec, 6.4% Overall Duty Cycle, 50 Vdc, I _{DQ} = 150 mA		0.07	

Table 3. ESD Protection Characteristics

Test Methodology	Class
Human Body Model (per JESD22-A114)	1B
Machine Model (per EIA/JESD22-A115)	B
Charge Device Model (per JESD22-C101)	IV

Table 4. Electrical Characteristics (T_A = 25°C unless otherwise noted)

Characteristic	Symbol	Min	Typ	Max	Unit
----------------	--------	-----	-----	-----	------

Off Characteristics ⁽²⁾

Gate-Source Leakage Current (V _{GS} = 5 Vdc, V _{DS} = 0 Vdc)	I _{GSS}	—	—	10	μAdc
Drain-Source Breakdown Voltage (V _{GS} = 0 Vdc, I _D = 165 mA)	V _{(BR)DSS}	110	—	—	Vdc
Zero Gate Voltage Drain Leakage Current (V _{DS} = 50 Vdc, V _{GS} = 0 Vdc)	I _{DSS}	—	—	10	μAdc
Zero Gate Voltage Drain Leakage Current (V _{DS} = 100 Vdc, V _{GS} = 0 Vdc)	I _{DSS}	—	—	100	μAdc

On Characteristics

Gate Threshold Voltage ⁽²⁾ (V _{DS} = 10 Vdc, I _D = 1000 μAdc)	V _{GS(th)}	0.9	1.6	2.4	Vdc
Gate Quiescent Voltage ⁽³⁾ (V _{DD} = 50 Vdc, I _D = 150 mAdc, Measured in Functional Test)	V _{GS(Q)}	1.5	2.2	3	Vdc
Drain-Source On-Voltage ⁽²⁾ (V _{GS} = 10 Vdc, I _D = 2.7 Adc)	V _{DS(on)}	—	0.15	—	Vdc

Dynamic Characteristics ⁽²⁾

Reverse Transfer Capacitance (V _{DS} = 50 Vdc ± 30 mV(rms)ac @ 1 MHz, V _{GS} = 0 Vdc)	C _{rss}	—	1.27	—	pF
Output Capacitance (V _{DS} = 50 Vdc ± 30 mV(rms)ac @ 1 MHz, V _{GS} = 0 Vdc)	C _{oss}	—	86.7	—	pF
Input Capacitance (V _{DS} = 50 Vdc, V _{GS} = 0 Vdc ± 30 mV(rms)ac @ 1 MHz)	C _{iss}	—	539	—	pF

Functional Tests ⁽³⁾ (In Freescale Test Fixture, 50 ohm system) V_{DD} = 50 Vdc, I_{DQ} = 150 mA, P_{out} = 1000 W Peak (100 W Avg.),
f = 1030 MHz, 128 μsec Pulse Width, 10% Duty Cycle

Power Gain	G _{ps}	19	20	22	dB
Drain Efficiency	η _D	54	56	—	%
Input Return Loss	IRL	—	-23	-9	dB

1. Refer to AN1955, *Thermal Measurement Methodology of RF Power Amplifiers*. Go to <http://www.freescale.com/rf>.
Select Documentation/Application Notes – AN1955.
2. Each side of device measured separately.
3. Measurement made with device in push-pull configuration.

(continued)

Table 4. Electrical Characteristics ($T_A = 25^\circ\text{C}$ unless otherwise noted) (continued)

Characteristic	Symbol	Min	Typ	Max	Unit
----------------	--------	-----	-----	-----	------

Typical Performance — 1030 MHz (In Freescale 1030 MHz Test Fixture, 50 ohm system) $V_{DD} = 50\text{ Vdc}$, $I_{DQ} = 150\text{ mA}$, $P_{out} = 1000\text{ W Peak}$ (100 W Avg.), $f = 1030\text{ MHz}$, Mode-S Pulse Train, 80 Pulses of 32 μsec On, 18 μsec Off, Repeated Every 40 msec, 6.4% Overall Duty Cycle

Power Gain	G_{ps}	—	19.8	—	dB
Drain Efficiency	η_D	—	59.0	—	%
Burst Droop	BD_{rp}	—	0.21	—	dB

Typical Performance — 1090 MHz (In Freescale 1090 MHz Test Fixture, 50 ohm system) $V_{DD} = 50\text{ Vdc}$, $I_{DQ} = 150\text{ mA}$, $P_{out} = 1000\text{ W Peak}$ (100 W Avg.), $f = 1090\text{ MHz}$, 128 μsec Pulse Width, 10% Duty Cycle

Power Gain	G_{ps}	—	21.4	—	dB
Drain Efficiency	η_D	—	56.3	—	%
Input Return Loss	IRL	—	-25.3	—	dB

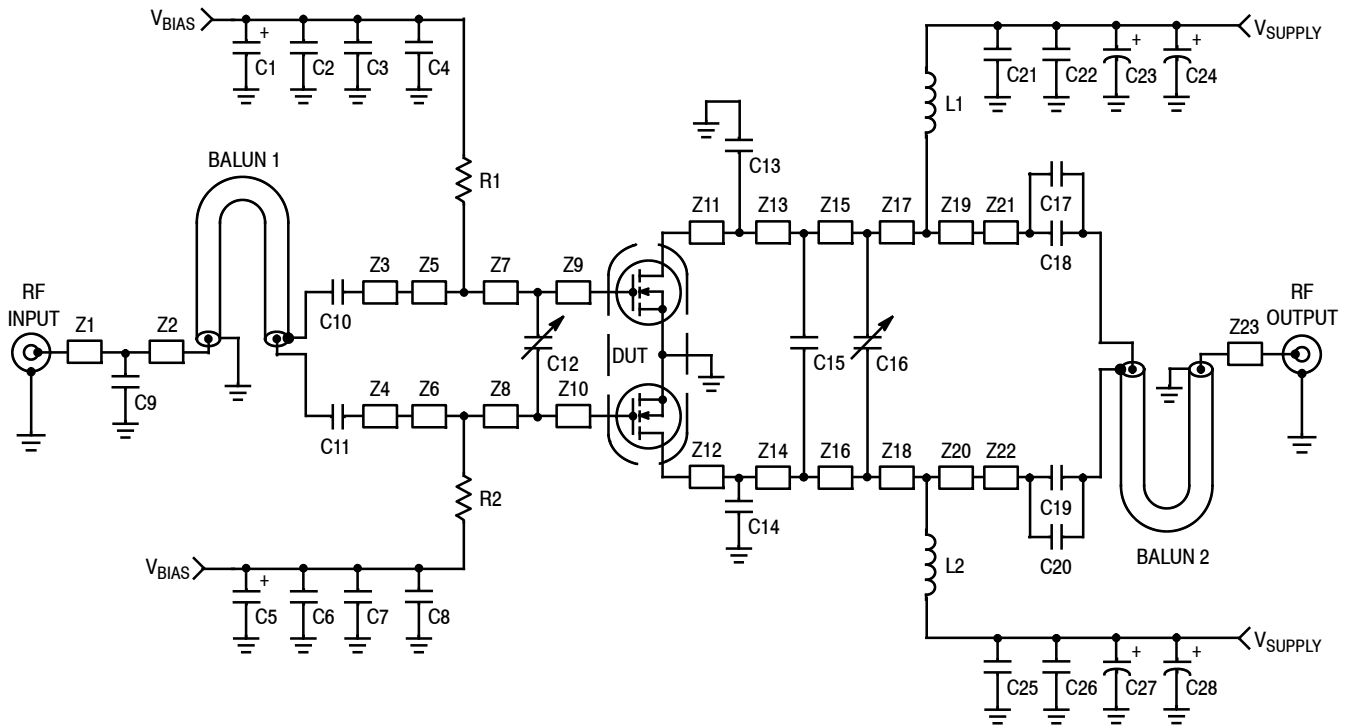

Z1	0.140" x 0.083"	Z13, Z14	0.143" x 0.631"
Z2	0.300" x 0.083"	Z15, Z16	0.135" x 0.631"
Z3, Z4	0.746" x 0.220"	Z17, Z18	0.102" x 0.632"
Z5, Z6	0.075" x 0.631"	Z19, Z20	0.130" x 0.631"
Z7, Z8	0.329" x 0.631"	Z21, Z22	0.736" x 0.215"
Z9, Z10	0.326" x 0.631"	Z23	0.410" x 0.083"
Z11, Z12	0.240" x 0.631"	PCB	Arlon CuClad 250GX-0300-55-22, 0.030", $\epsilon_r = 2.55$

Figure 2. MMRF1007HR5(HSR5) Test Circuit Schematic

Table 5. MMRF1007HR5(HSR5) Test Circuit Component Designations and Values

Part	Description	Manufacturer	Part Number
Balun 1, 2	Balun Anaren	3A412	Anaren
C1, C5	22 μ F, 25 V Tantalum Capacitors	TPSD226M025R	AVX
C2, C6	2.2 μ F, 50 V Chip Capacitors	C1825C225J5RAC	Kemet
C3, C7	0.22 μ F, 100 V Chip Capacitors	C1210C224K1RAC	Kemet
C4, C8, C17, C18, C19, C20, C21, C25	36 pF Chip Capacitors	ATC100B360JT500XT	ATC
C9	1.0 pF Chip Capacitor	ATC100B1R0CT500XT	ATC
C12, C16	0.8-8.0 pF Variable Capacitors	27291SL	Johanson
C10, C11, C13, C14, C15	5.1 pF Chip Capacitors	ATC100B5R1CT500XT	ATC
C22, C26	0.022 μ F, 100 V Chip Capacitors	C1825C223K1GAC	Kemet
C23, C24, C27, C28	470 μ F, 63 V Electrolytic Capacitors	MCGPR63V477M13X26-RH	Multicomp
L1, L2	Inductors 3 Turn	GA3094-AL	Coilcraft
R1, R2	1000 Ω , 1/3 W Chip Resistors	CRCW12101001FKEA	Vishay

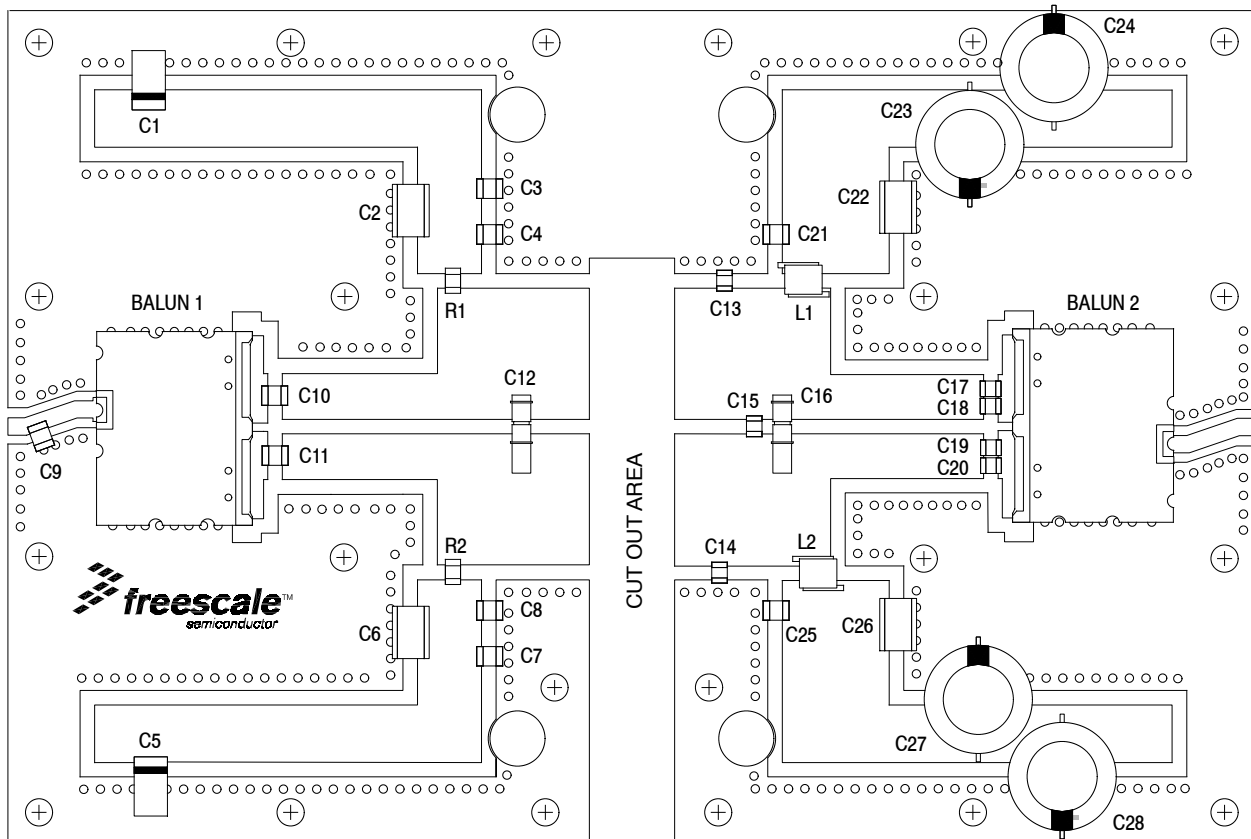
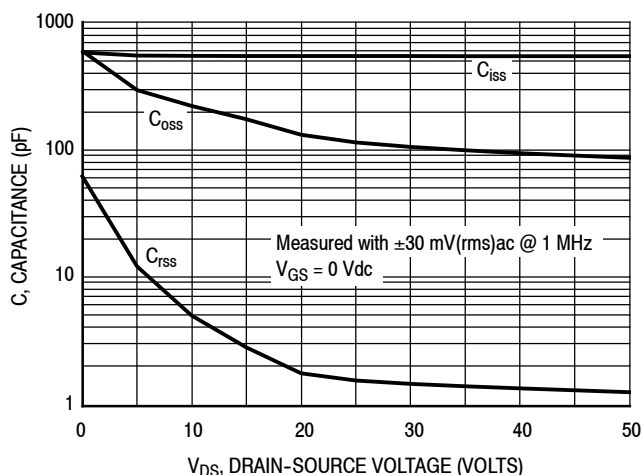

Figure 3. MMRF1007HR5(HSR5) Test Circuit Component Layout

TYPICAL CHARACTERISTICS



Note: Each side of device measured separately.
Figure 4. Capacitance versus Drain-Source Voltage

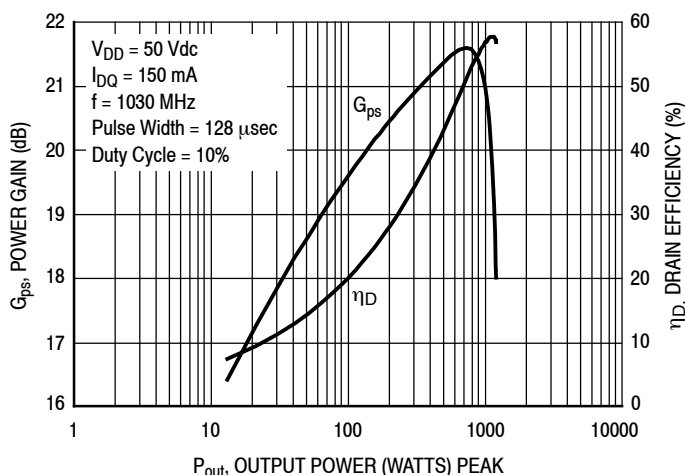

Figure 5. Power Gain and Drain Efficiency versus Output Power

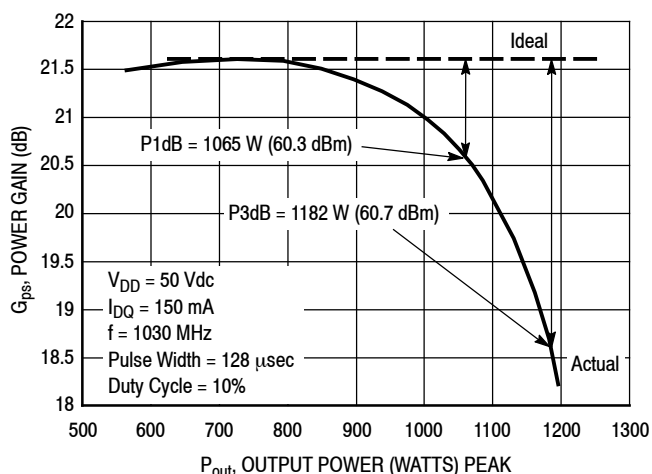

Figure 6. Power Gain versus Output Power

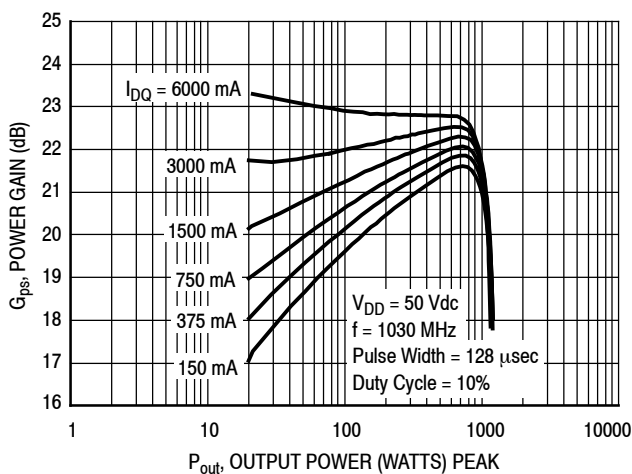

Figure 7. Power Gain versus Output Power

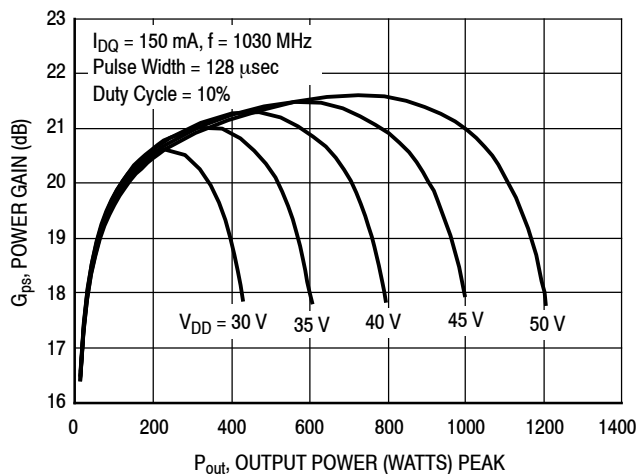

Figure 8. Power Gain versus Output Power

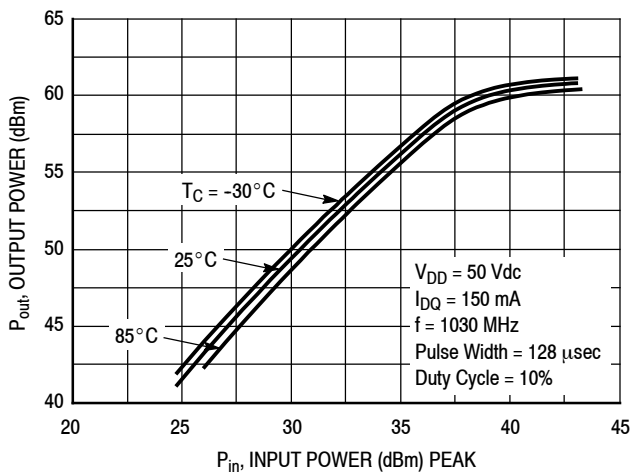

Figure 9. Output Power versus Input Power

TYPICAL CHARACTERISTICS

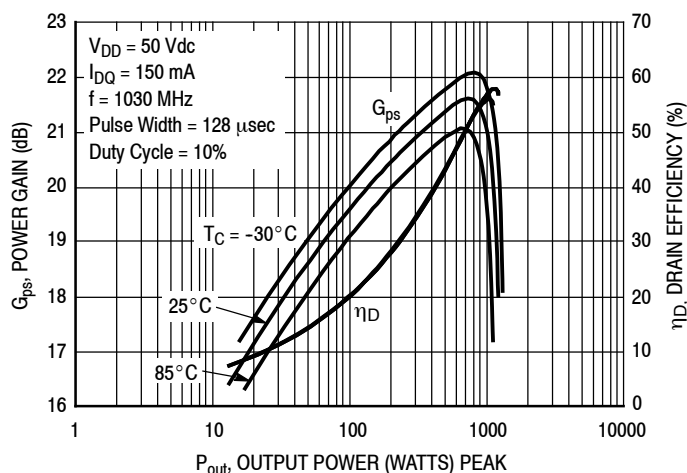
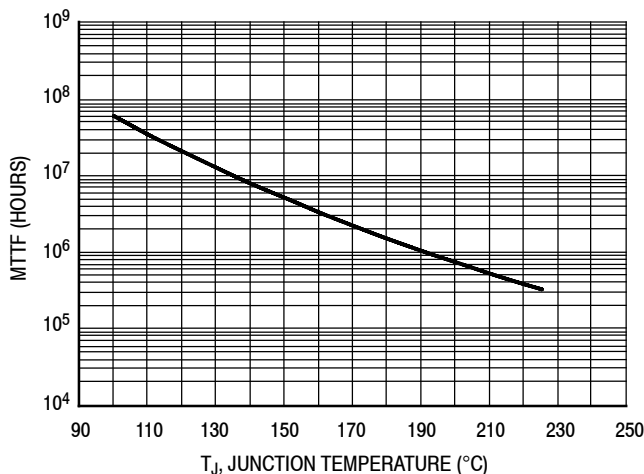

Figure 10. Power Gain and Drain Efficiency versus Output Power



This above graph displays calculated MTTF in hours when the device is operated at $V_{DD} = 50$ Vdc, $P_{out} = 1000$ W Peak, Pulse Width = 128 μ sec, Duty Cycle = 10%, and $\eta_D = 56\%$.

MTTF calculator available at <http://www.freescale.com/rf>. Select Software & Tools/Development Tools/Calculators to access MTTF calculators by product.

Figure 11. MTTF versus Junction Temperature - 128 μ sec, 10% Duty Cycle

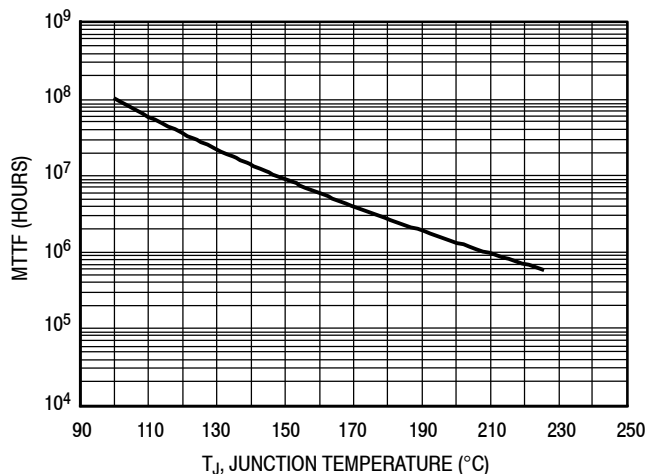

This above graph displays calculated MTTF in hours when the device is operated at $V_{DD} = 50$ Vdc, $P_{out} = 1000$ W Peak, Mode-S Pulse Train, Pulse Width = 32 μ sec, Duty Cycle = 6.4%, and $\eta_D = 59\%$.

MTTF calculator available at <http://www.freescale.com/rf>. Select Software & Tools/Development Tools/Calculators to access MTTF calculators by product.

Figure 12. MTTF versus Junction Temperature - Mode-S

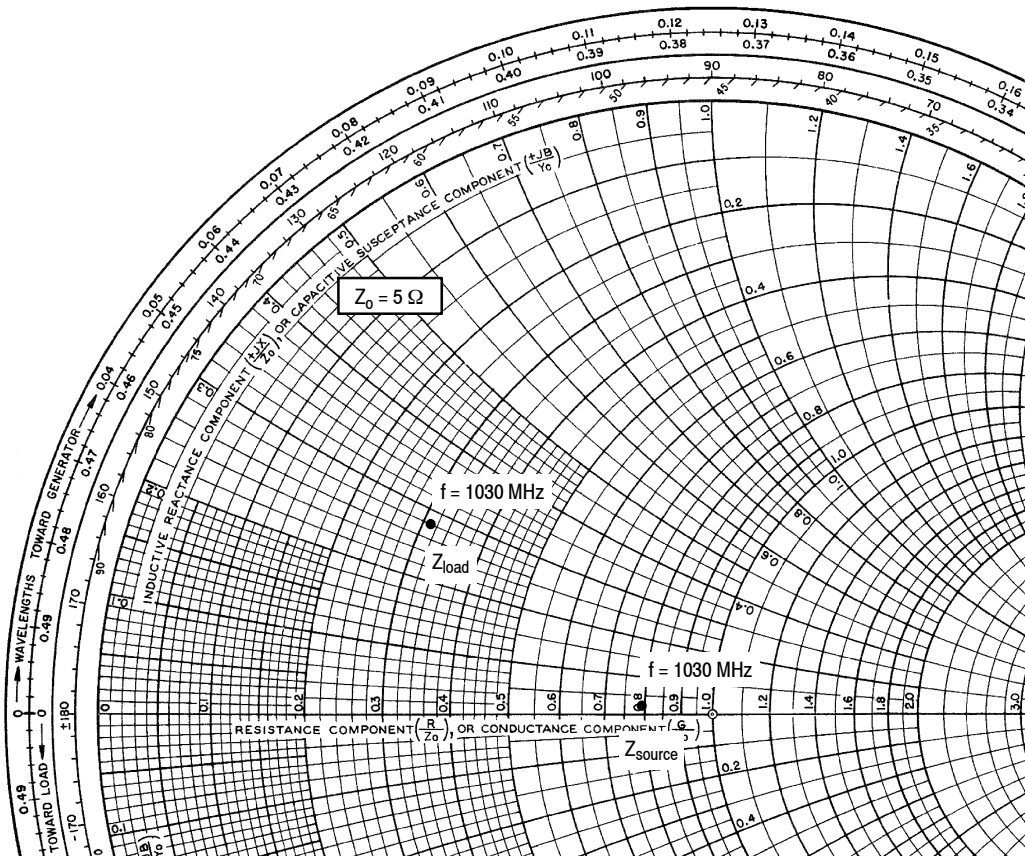

$V_{DD} = 50 \text{ Vdc}$, $I_{DQ} = 150 \text{ mA}$, $P_{out} = 1000 \text{ W Peak}$

f MHz	Z_{source} Ω	Z_{load} Ω
1030	$3.93 + j0.09$	$1.54 + j1.42$

Z_{source} = Test circuit impedance as measured from gate to gate, balanced configuration.

Z_{load} = Test circuit impedance as measured from drain to drain, balanced configuration.

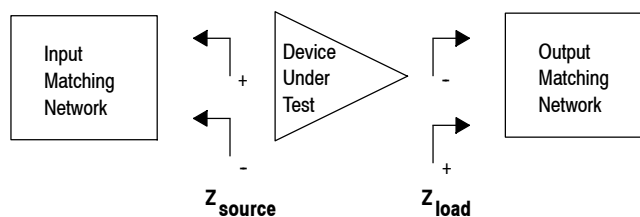

Figure 13. Series Equivalent Source and Load Impedance

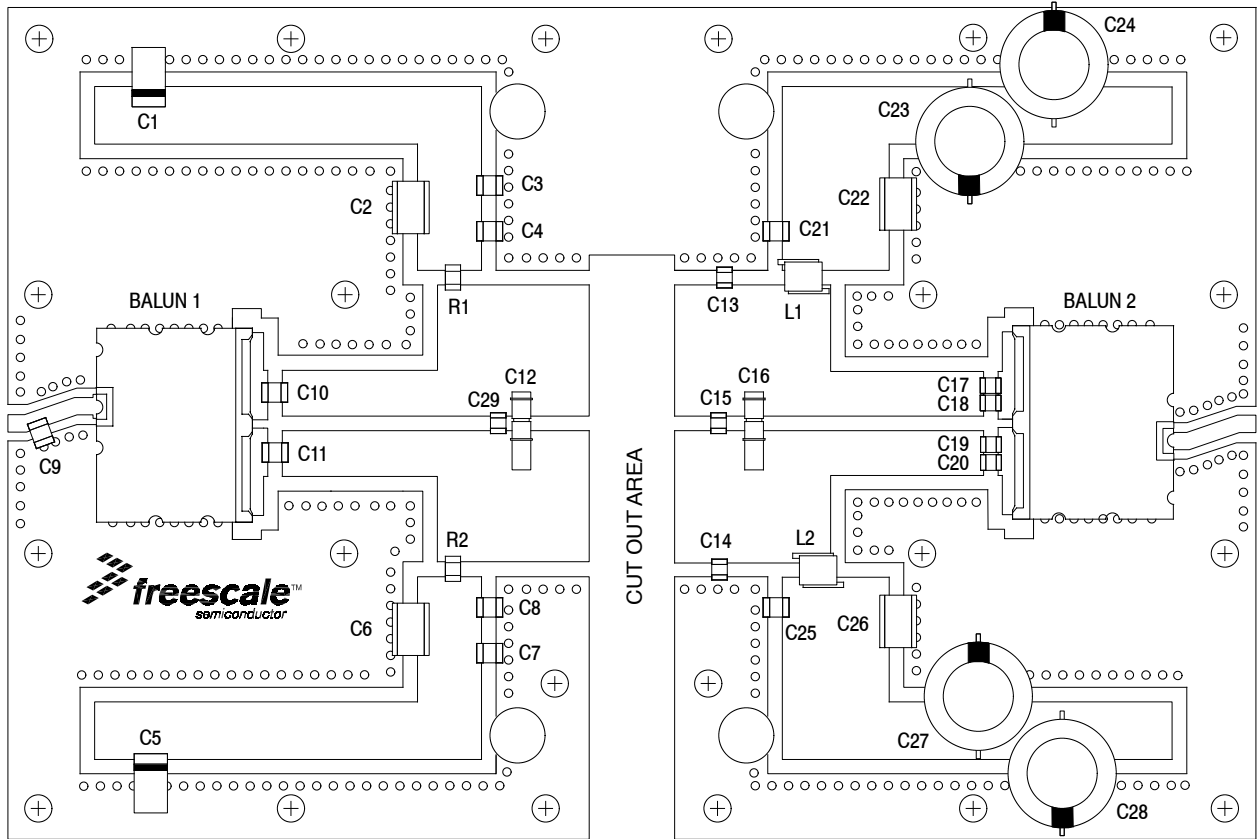

Figure 14. MMRF1007HR5(HSR5) Test Circuit Component Layout — 1090 MHz

Table 6. MMRF1007HR5(HSR5) Test Circuit Component Designations and Values — 1090 MHz

Part	Description	Manufacturer	Part Number
Balun 1, 2	Balun Anaren	3A412	Anaren
C1, C5	22 μ F, 25 V Tantalum Capacitors	TPSD226M025R0200	AVX
C2, C6	2.2 μ F, 50 V 1825 Chip Capacitors	C1825C225J5RAC-TU	Kemet
C3, C7	0.22 μ F, 100 V Chip Capacitors	C1210C224K1RAC-TU	Kemet
C4, C8, C17, C18, C19, C20, C21, C25	36 pF Chip Capacitors	ATC100B360JT500XT	ATC
C9	1.0 pF Chip Capacitor	ATC100B1R0BT500XT	ATC
C12, C16	0.8–8.0 pF Variable Capacitors	27291SL	Johanson
C10, C11, C13, C14, C15, C29	5.1 pF Chip Capacitors	ATC100B5R1CT500XT	ATC
C22, C26	0.022 μ F, 100 V Chip Capacitors	C1825C223K1GAC	Kemet
C23, C24, C27, C28	470 μ F, 63 V Electrolytic Capacitors	MCGPR63V477M13X26-RH	Multicom
L1, L2	Inductors 3 Turn	GA3094-ALC	Coilcraft
R1, R2	1000 Ω , 1/4 W Chip Resistors	CRCW12061K00FKEA	Vishay
PCB	CuClad, 0.030", $\epsilon_r = 2.55$	250GX-0300-55-22	Arlon

TYPICAL CHARACTERISTICS — 1090 MHZ

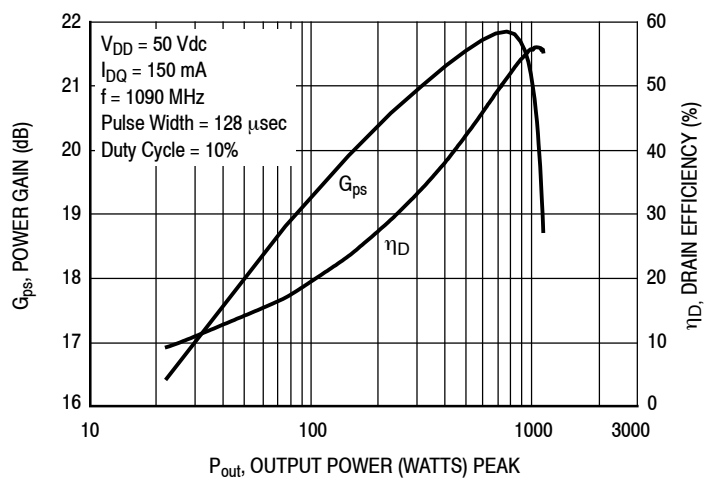
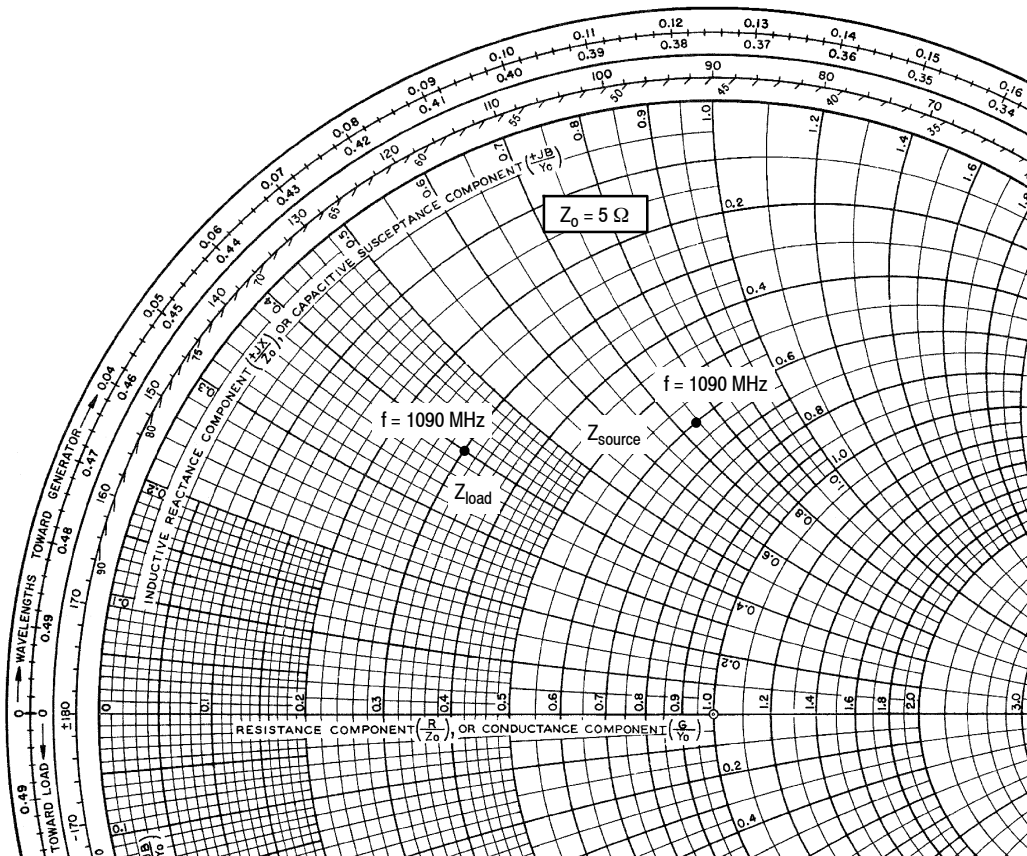

Figure 15. Power Gain and Drain Efficiency versus Output Power



$V_{DD} = 50 \text{ Vdc}$, $I_{DQ} = 150 \text{ mA}$, $P_{out} = 1000 \text{ W Peak}$

f MHz	Z_{source} Ω	Z_{load} Ω
1090	$2.98 + j3.68$	$1.51 + j2.02$

Z_{source} = Test circuit impedance as measured from gate to gate, balanced configuration.

Z_{load} = Test circuit impedance as measured from drain to drain, balanced configuration.

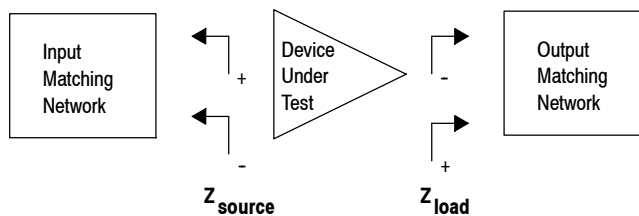
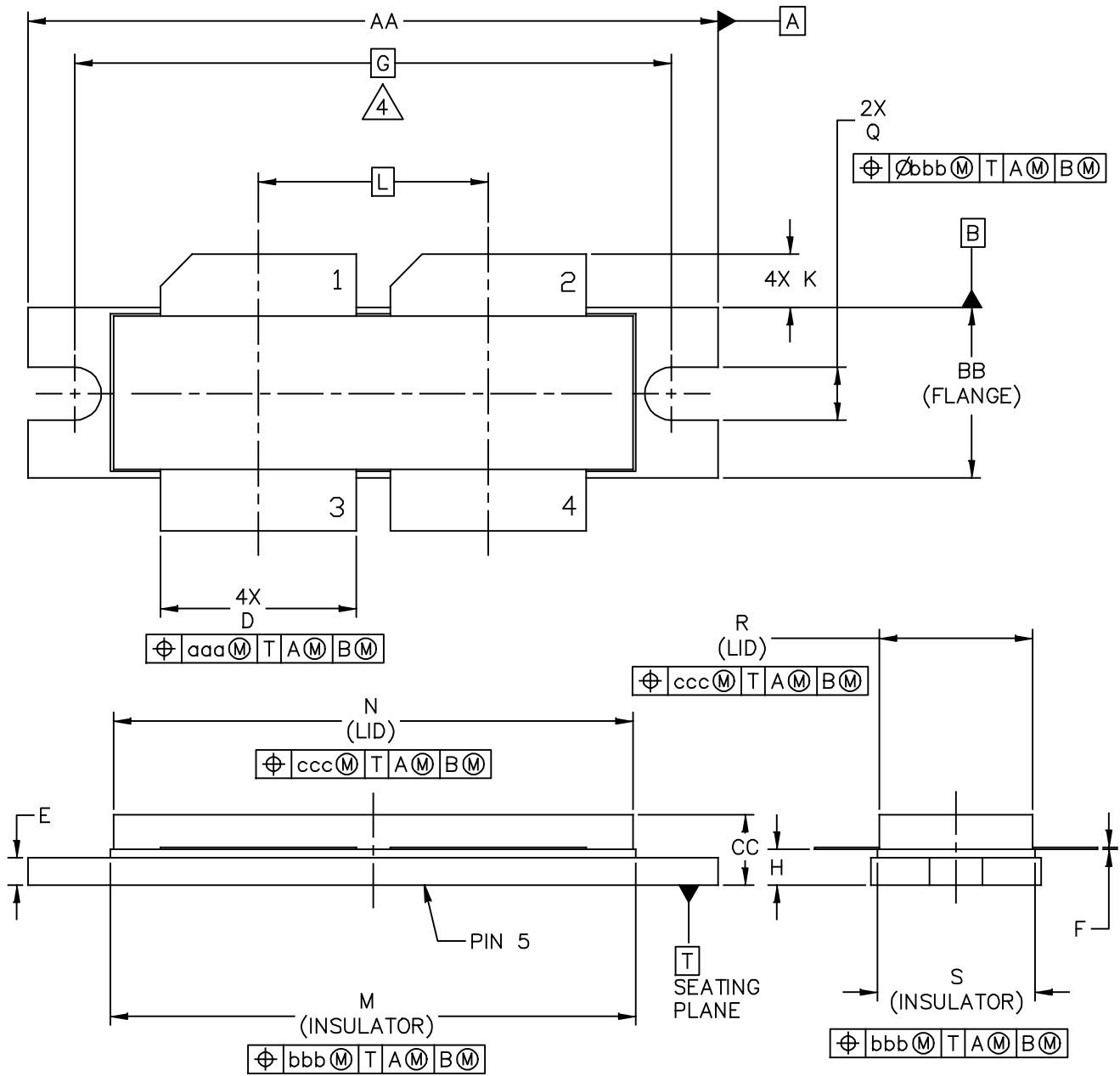

Figure 16. Series Equivalent Source and Load Impedance — 1090 MHz

PACKAGE DIMENSIONS



© FREESCALE SEMICONDUCTOR, INC. ALL RIGHTS RESERVED.	MECHANICAL OUTLINE	PRINT VERSION NOT TO SCALE
TITLE: NI-1230-4H	DOCUMENT NO: 98ASB16977C STANDARD: NON-JEDEC	REV: F
		28 FEB 2013

NOTES:

1. INTERPRET DIMENSIONS AND TOLERANCES PER ASME Y14.5M-1994.
2. CONTROLLING DIMENSION: INCH
3. DIMENSION H IS MEASURED .030 INCH (0.762 MM) AWAY FROM PACKAGE BODY.
4. RECOMMENDED BOLT CENTER DIMENSION OF 1.52 INCH (38.61 MM) BASED ON M3 SCREW.

DIM	INCH		MILLIMETER		DIM	INCH		MILLIMETER	
	MIN	MAX	MIN	MAX		MIN	MAX	MIN	MAX
AA	1.615	1.625	41.02	41.28	N	1.218	1.242	30.94	31.55
BB	.395	.405	10.03	10.29	Q	.120	.130	3.05	3.30
CC	.170	.190	4.32	4.83	R	.355	.365	9.02	9.27
D	.455	.465	11.56	11.81	S	.365	.375	9.27	9.53
E	.062	.066	1.57	1.68					
F	.004	.007	0.10	0.18					
G	1.400 BSC		35.56 BSC		aaa	.013		0.33	
H	.082	.090	2.08	2.29	bbb	.010		0.25	
K	.117	.137	2.97	3.48	ccc	.020		0.51	
L	.540 BSC		13.72 BSC						
M	1.219	1.241	30.96	31.52					

© FREESCALE SEMICONDUCTOR, INC. ALL RIGHTS RESERVED.		MECHANICAL OUTLINE	PRINT VERSION NOT TO SCALE
TITLE:		DOCUMENT NO: 98ASB16977C	REV: F
NI-1230-4H		STANDARD: NON-JEDEC	
		28 FEB 2013	

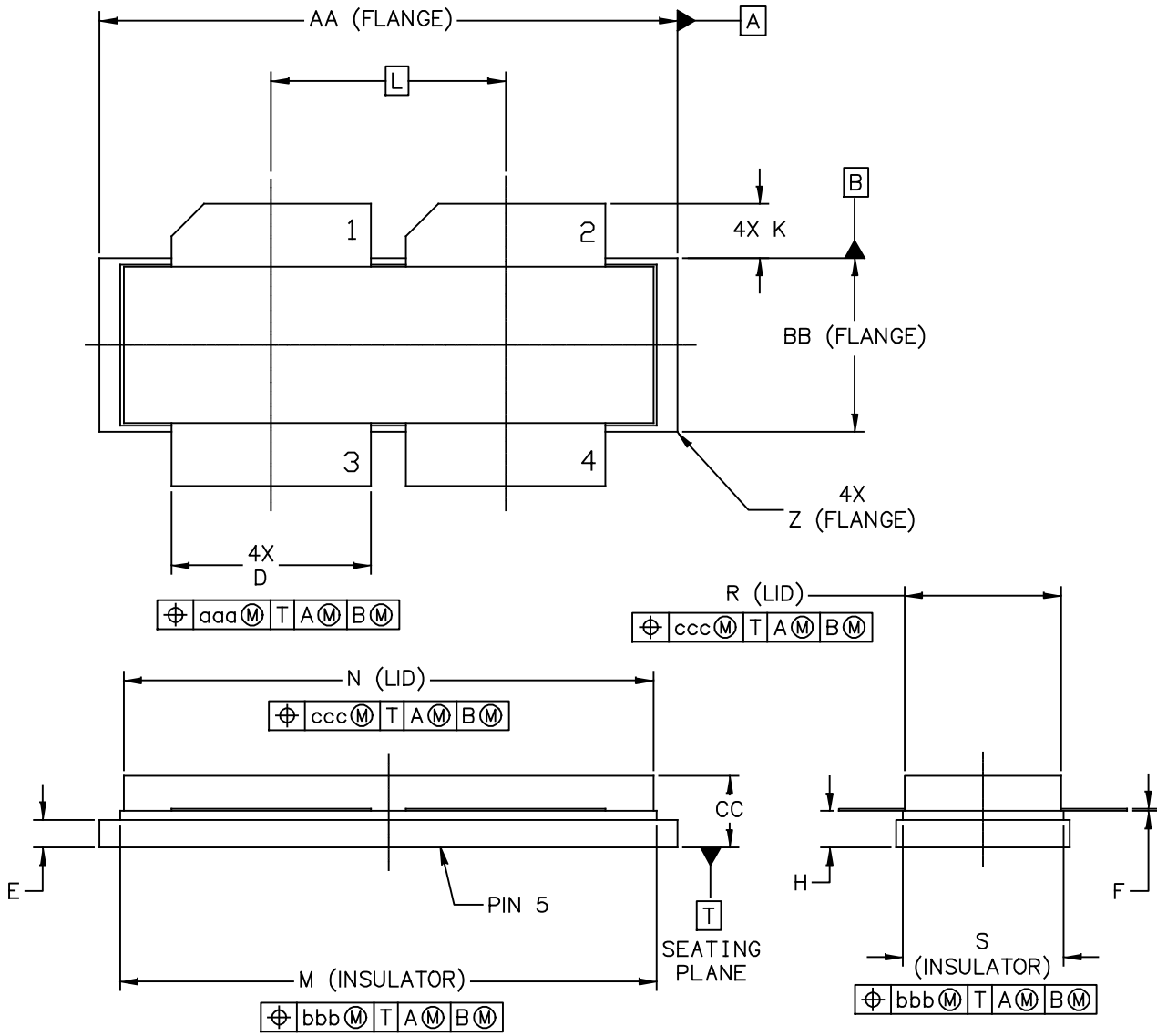

© FREESCALE SEMICONDUCTOR, INC. ALL RIGHTS RESERVED.	MECHANICAL OUTLINE	PRINT VERSION NOT TO SCALE
TITLE: NI-1230-4S	DOCUMENT NO: 98ARB18247C	REV: G
	STANDARD: NON-JEDEC	
	01 MAR 2013	

NOTES:

1. INTERPRET DIMENSIONS AND TOLERANCES PER ASME Y14.5M-1994.
2. CONTROLLING DIMENSION: INCH
3. DIMENSION H IS MEASURED .030 INCH (0.762 MM) AWAY FROM PACKAGE BODY

DIM	INCHES		MILLIMETERS		DIM	INCHES		MILLIMETERS	
	MIN	MAX	MIN	MAX		MIN	MAX	MIN	MAX
AA	1.265	1.275	32.13	32.39	R	.355	.365	9.02	9.27
BB	.395	.405	10.03	10.29	S	.365	.375	9.27	9.53
CC	.170	.190	4.32	4.83	Z	R.000	R.040	R0.00	R1.02
D	.455	.465	11.56	11.81					
E	.062	.066	1.57	1.68	aaa	.013		0.33	
F	.004	.007	0.10	0.18	bbb	.010		0.25	
H	.082	.090	2.08	2.29	ccc	.020		0.51	
K	.117	.137	2.97	3.48					
L	.540 BSC		13.72 BSC						
M	1.219	1.241	30.96	31.52					
N	1.218	1.242	30.94	31.55					
© FREESCALE SEMICONDUCTOR, INC. ALL RIGHTS RESERVED.			MECHANICAL OUTLINE			PRINT VERSION NOT TO SCALE			
TITLE:					DOCUMENT NO: 98ARB18247C		REV: G		
NI-1230-4S					STANDARD: NON-JEDEC				
					01 MAR 2013				

PRODUCT DOCUMENTATION

Refer to the following documents to aid your design process.

Application Notes

- AN1955: Thermal Measurement Methodology of RF Power Amplifiers

Engineering Bulletins

- EB212: Using Data Sheet Impedances for RF LDMOS Devices

REVISION HISTORY

The following table summarizes revisions to this document.

Revision	Date	Description
0	Dec. 2013	• Initial Release of Data Sheet

How to Reach Us:

Home Page:
freescale.com

Web Support:
freescale.com/support

Information in this document is provided solely to enable system and software implementers to use Freescale products. There are no express or implied copyright licenses granted hereunder to design or fabricate any integrated circuits based on the information in this document.

Freescale reserves the right to make changes without further notice to any products herein. Freescale makes no warranty, representation, or guarantee regarding the suitability of its products for any particular purpose, nor does Freescale assume any liability arising out of the application or use of any product or circuit, and specifically disclaims any and all liability, including without limitation consequential or incidental damages. "Typical" parameters that may be provided in Freescale data sheets and/or specifications can and do vary in different applications, and actual performance may vary over time. All operating parameters, including "typicals," must be validated for each customer application by customer's technical experts. Freescale does not convey any license under its patent rights nor the rights of others. Freescale sells products pursuant to standard terms and conditions of sale, which can be found at the following address: freescale.com/SalesTermsandConditions.

Freescale and the Freescale logo are trademarks of Freescale Semiconductor, Inc., Reg. U.S. Pat. & Tm. Off. All other product or service names are the property of their respective owners.

© 2013 Freescale Semiconductor, Inc.

Данный компонент на территории Российской Федерации

Вы можете приобрести в компании MosChip.

Для оперативного оформления запроса Вам необходимо перейти по данной ссылке:

<http://moschip.ru/get-element>

Вы можете разместить у нас заказ для любого Вашего проекта, будь то серийное производство или разработка единичного прибора.

В нашем ассортименте представлены ведущие мировые производители активных и пассивных электронных компонентов.

Нашей специализацией является поставка электронной компонентной базы двойного назначения, продукции таких производителей как XILINX, Intel (ex.ALTERA), Vicor, Microchip, Texas Instruments, Analog Devices, Mini-Circuits, Amphenol, Glenair.

Сотрудничество с глобальными дистрибьюторами электронных компонентов, предоставляет возможность заказывать и получать с международных складов практически любой перечень компонентов в оптимальные для Вас сроки.

На всех этапах разработки и производства наши партнеры могут получить квалифицированную поддержку опытных инженеров.

Система менеджмента качества компании отвечает требованиям в соответствии с ГОСТ Р ИСО 9001, ГОСТ РВ 0015-002 и ЭС РД 009

Офис по работе с юридическими лицами:

105318, г.Москва, ул.Щербаковская д.3, офис 1107, 1118, ДЦ «Щербаковский»

Телефон: +7 495 668-12-70 (многоканальный)

Факс: +7 495 668-12-70 (доб.304)

E-mail: info@moschip.ru

Skype отдела продаж:

moschip.ru

moschip.ru_4

moschip.ru_6

moschip.ru_9