

TVS Diodes

Transient Voltage Suppressor Diodes

ESD112-B1-02 Series

Bi-directional Ultra-low Capacitance ESD / Transient Protection Diode

ESD112-B1-02ELS
ESD112-B1-02EL

Data Sheet

Rev. 1.3, 2013-11-27
Final

Revision History: Rev.1.2, 2013-06-10

Page or Item	Subjects (major changes since previous revision)
Rev. 1.3, 2013-11-27: Final Data Sheet	
	ESD112-B1-02EL Status change to final

Trademarks of Infineon Technologies AG

AURIX™, BlueMoon™, C166™, CanPAK™, CIPOS™, CIPURSE™, COMNEON™, EconoPACK™, CoolMOS™, CoolSET™, CORECONTROL™, CROSSAVE™, DAVE™, EasyPIM™, EconoBRIDGE™, EconoDUAL™, EconoPIM™, EiceDRIVER™, eupec™, FCOS™, HITFET™, HybridPACK™, I²RF™, ISOFACE™, IsoPACK™, MIPAQ™, ModSTACK™, my-d™, NovalithIC™, OmniTune™, OptiMOS™, ORIGA™, PRIMARION™, PrimePACK™, PrimeSTACK™, PRO-SIL™, PROFET™, RASIC™, ReverSave™, SatRIC™, SIEGET™, SINDRION™, SIPMOS™, SMARTi™, SmartLEWIS™, SOLID FLASH™, TEMPFET™, thinQ!™, TRENCHSTOP™, TriCore™, X-GOLD™, X-PMU™, XMM™, XPOSYS™.

Other Trademarks

Advance Design System™ (ADS) of Agilent Technologies, AMBA™, ARM™, MULTI-ICE™, KEIL™, PRIMECELL™, REALVIEW™, THUMB™, μVision™ of ARM Limited, UK. AUTOSAR™ is licensed by AUTOSAR development partnership. Bluetooth™ of Bluetooth SIG Inc. CAT-ig™ of DECT Forum. COLOSSUS™, FirstGPS™ of Trimble Navigation Ltd. EMV™ of EMVCo, LLC (Visa Holdings Inc.). EPCOS™ of Epcos AG. FLEXGO™ of Microsoft Corporation. FlexRay™ is licensed by FlexRay Consortium. HYPERTERMINAL™ of Hilgraeve Incorporated. IEC™ of Commission Electrotechnique Internationale. IrDA™ of Infrared Data Association Corporation. ISO™ of INTERNATIONAL ORGANIZATION FOR STANDARDIZATION. MATLAB™ of MathWorks, Inc. MAXIM™ of Maxim Integrated Products, Inc. MICROTEC™, NUCLEUS™ of Mentor Graphics Corporation. Mifare™ of NXP. MIPI™ of MIPI Alliance, Inc. MIPS™ of MIPS Technologies, Inc., USA. muRata™ of MURATA MANUFACTURING CO., MICROWAVE OFFICE™ (MWO) of Applied Wave Research Inc., OmniVision™ of OmniVision Technologies, Inc. Openwave™ Openwave Systems Inc. RED HAT™ Red Hat, Inc. RFMD™ RF Micro Devices, Inc. SIRIUS™ of Sirius Satellite Radio Inc. SOLARIS™ of Sun Microsystems, Inc. SPANSION™ of Spansion LLC Ltd. Symbian™ of Symbian Software Limited. TAIYO YUDEN™ of Taiyo Yuden Co. TEAKLITE™ of CEVA, Inc. TEKTRONIX™ of Tektronix Inc. TOKO™ of TOKO KABUSHIKI KAISHA TA. UNIX™ of X/Open Company Limited. VERILOG™, PALLADIUM™ of Cadence Design Systems, Inc. VLYNQ™ of Texas Instruments Incorporated. VXWORKS™, WIND RIVER™ of WIND RIVER SYSTEMS, INC. ZETEX™ of Diodes Zetex Limited.

Last Trademarks Update 2010-10-26

1 Bi-directional Ultra-low Capacitance ESD / Transient Protection Diode

1.1 Features

- ESD / transient protection of RF signal lines according to:
 - IEC61000-4-2 (ESD): ± 20 kV (air/contact)
 - IEC61000-4-4 (EFT): ± 40 A (5/50 ns)
 - IEC61000-4-5 (surge): ± 3 A (8/20 μ s)
- Maximum working voltage: $V_{RWM} \pm 5.3$ V
- Extremely low capacitance: $C_L = 0.2$ pF (typical)
- Low clamping voltage: $V_{CL} = 29$ V (typical) at $I_{PP} = 16$ A
- Very low reverse current $I_R < 1$ nA typ.
- Very small form factor down to $0.62 \times 0.32 \times 0.31$ mm³
- Pb-free (RoHS compliant) and halogen free package



1.2 Application Examples

- ESD protection of sensitive RF signal lines, Bluetooth Class 2, Automated Meter Reading
- RF antenna protection, frontend module, GPS, mobile TV, FM radio, UWB

1.3 Product Description

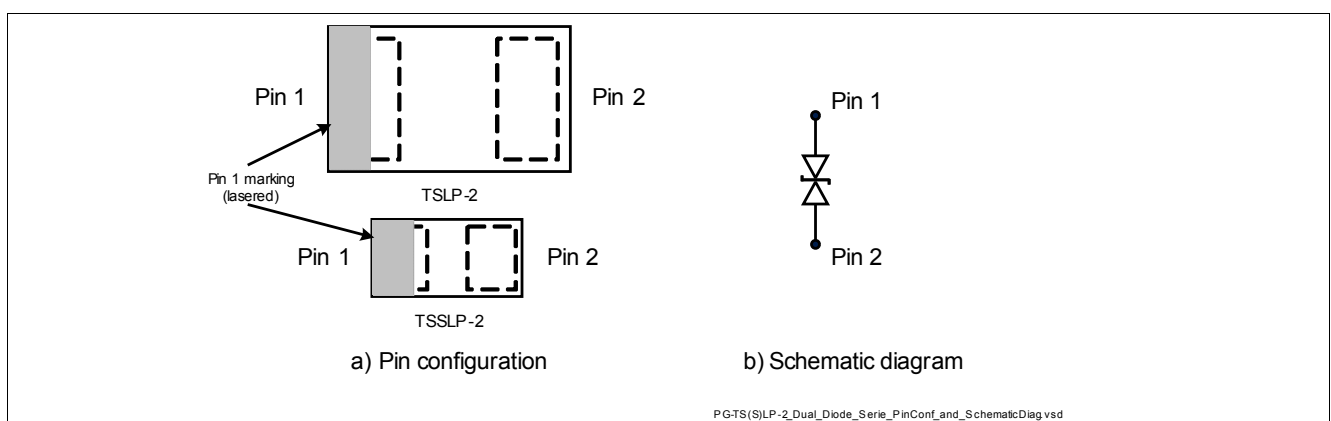

Figure 1-1 Pin Configuration and Schematic Diagram

Table 1-1 Ordering Information

Type	Package	Configuration	Marking code
ESD112-B1-02ELS	TSSLP-2-4	1 line, bi-directional	<u>I</u>
ESD112-B1-02EL	TSLP-2-20	1 line, bi-directional	TE

2 Characteristics

Table 2-1 Maximum Ratings at $T_A = 25\text{ }^\circ\text{C}$, unless otherwise specified

Parameter	Symbol	Values			Unit
		Min.	Typ.	Max.	
ESD air / contact discharge ¹⁾	V_{ESD}	-20	–	20	kV
Peak pulse current ($t_p = 8/20\text{ }\mu\text{s}$) ²⁾	I_{PP}	-3	–	3	A
Operating temperature range	T_{OP}	-55	–	125	$^\circ\text{C}$
Storage temperature	T_{stg}	-65	–	150	$^\circ\text{C}$

1) V_{ESD} according to IEC61000-4-2

2) I_{PP} according to IEC61000-4-5

Attention: Stresses above the max. values listed here may cause permanent damage to the device. Exposure to absolute maximum rating conditions for extended periods may affect device reliability. Maximum ratings are absolute ratings; exceeding only one of these values may cause irreversible damage to the integrated circuit.

2.1 Electrical Characteristics at $T_A=25\text{ }^\circ\text{C}$, unless otherwise specified

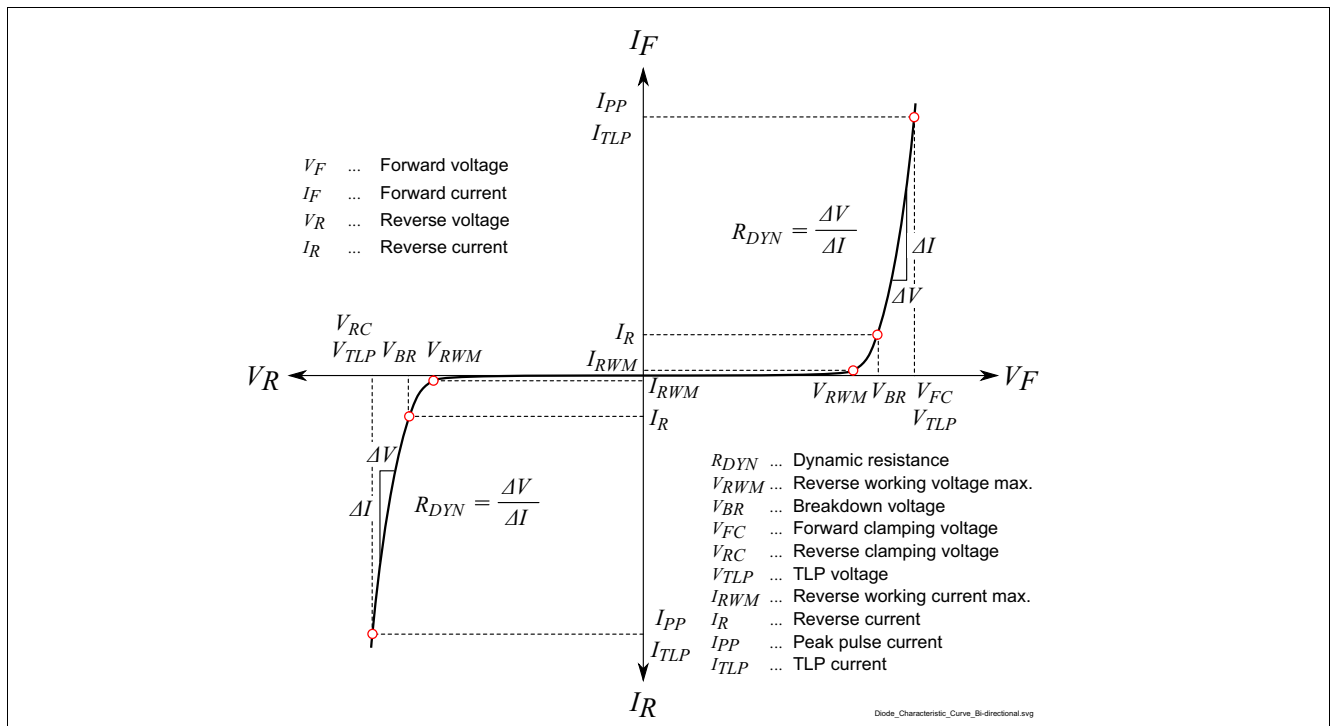

Figure 2-1 Definitions of electrical characteristics

Characteristics
Table 2-2 DC Characteristics at $T_A = 25\text{ }^\circ\text{C}$, unless otherwise specified

Parameter	Symbol	Values			Unit	Note / Test Condition
		Min.	Typ.	Max.		
Reverse working voltage	V_{RWM}	-5.3	-	5.3	V	
Breakdown voltage	V_{BR}	7	-	-	V	$I_R = 1\text{ mA}$, from pin 1 to pin 2, from pin 2 to pin 1
Reverse current	I_R	-	<1	50	nA	$V_R = 5.3\text{ V}$

Table 2-3 RF Characteristics at $T_A = 25\text{ }^\circ\text{C}$, unless otherwise specified

Parameter	Symbol	Values			Unit	Note / Test Condition
		Min.	Typ.	Max.		
Diode capacitance	C_L	-	0.23	0.4	pF	$V_R = 0\text{ V}, f = 1\text{ MHz}$
		-	0.2	0.4		$V_R = 0\text{ V}, f = 1\text{ GHz}$
Series inductance	L_S	-	0.2	-	nH	ESD112-B1-02ELS
		-	0.4	-		ESD112-B1-02EL

Table 2-4 ESD Characteristics at $T_A = 25\text{ }^\circ\text{C}$, unless otherwise specified

Parameter	Symbol	Values			Unit	Note / Test Condition
		Min.	Typ.	Max.		
Clamping voltage ²⁾	V_{CL}	-	29	-	V	$I_{TLP} = 16\text{ A}$
		-	44	-		$I_{TLP} = 30\text{ A}$
Clamping voltage ¹⁾		-	11	17		$I_{PP} = 1\text{ A}$
		-	15	21		$I_{PP} = 3\text{ A}$
Dynamic resistance ²⁾	R_{DYN}	-	1	-	Ω	

1) I_{PP} according to IEC61000-4-5 ($t_p = 8/20\text{ }\mu\text{s}$)

2) Please refer to Application Note AN210 [4]. TLP parameter: $Z_0 = 50\text{ }\Omega$, $t_p = 100\text{ ns}$, $t_r = 300\text{ ps}$, averaging window: $t_1 = 30\text{ ns}$ to $t_2 = 60\text{ ns}$, extraction of dynamic resistance using least squares fit of TLP characteristics between $I_{TLP1} = 10\text{ A}$ and $I_{TLP2} = 40\text{ A}$.

2.2 Typical Characteristics at $T_A = 25\text{ }^\circ\text{C}$, unless otherwise specified

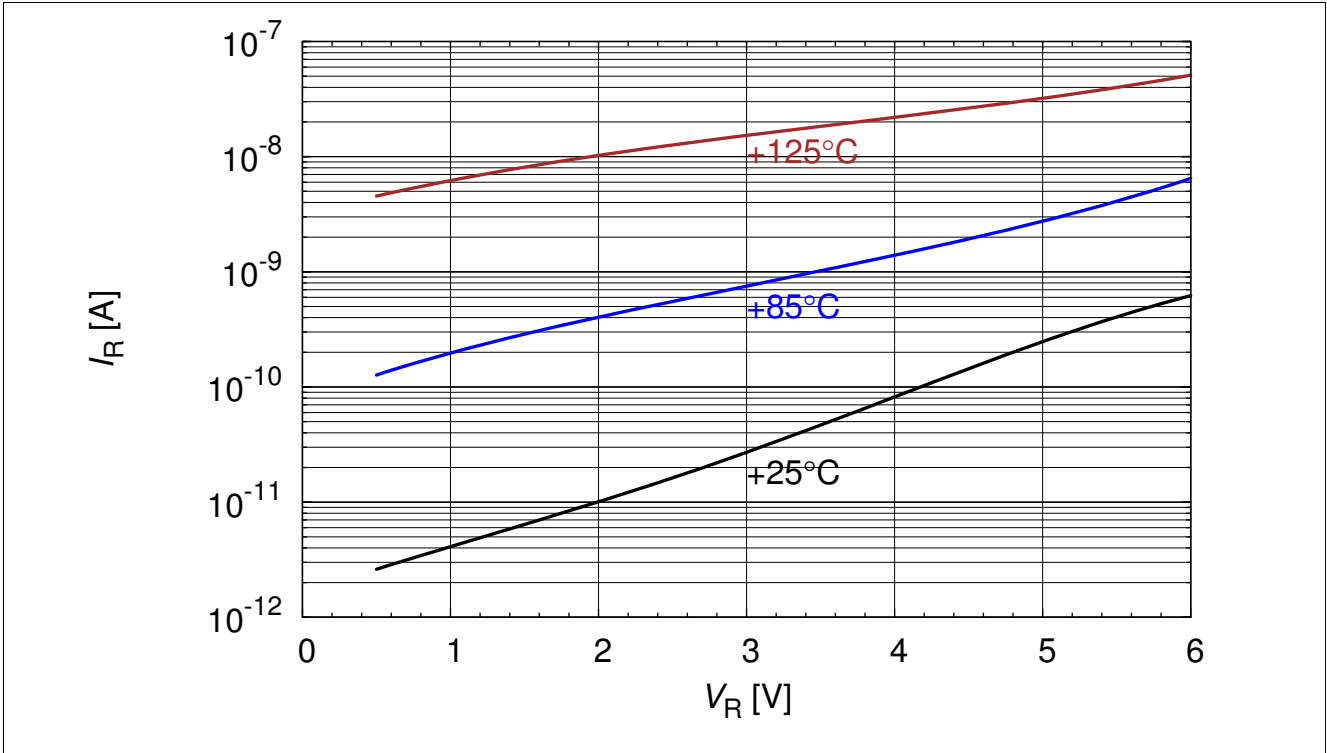

Figure 2-2 Reverse current: $I_R = f(V_R)$, $T_A = \text{parameter}$

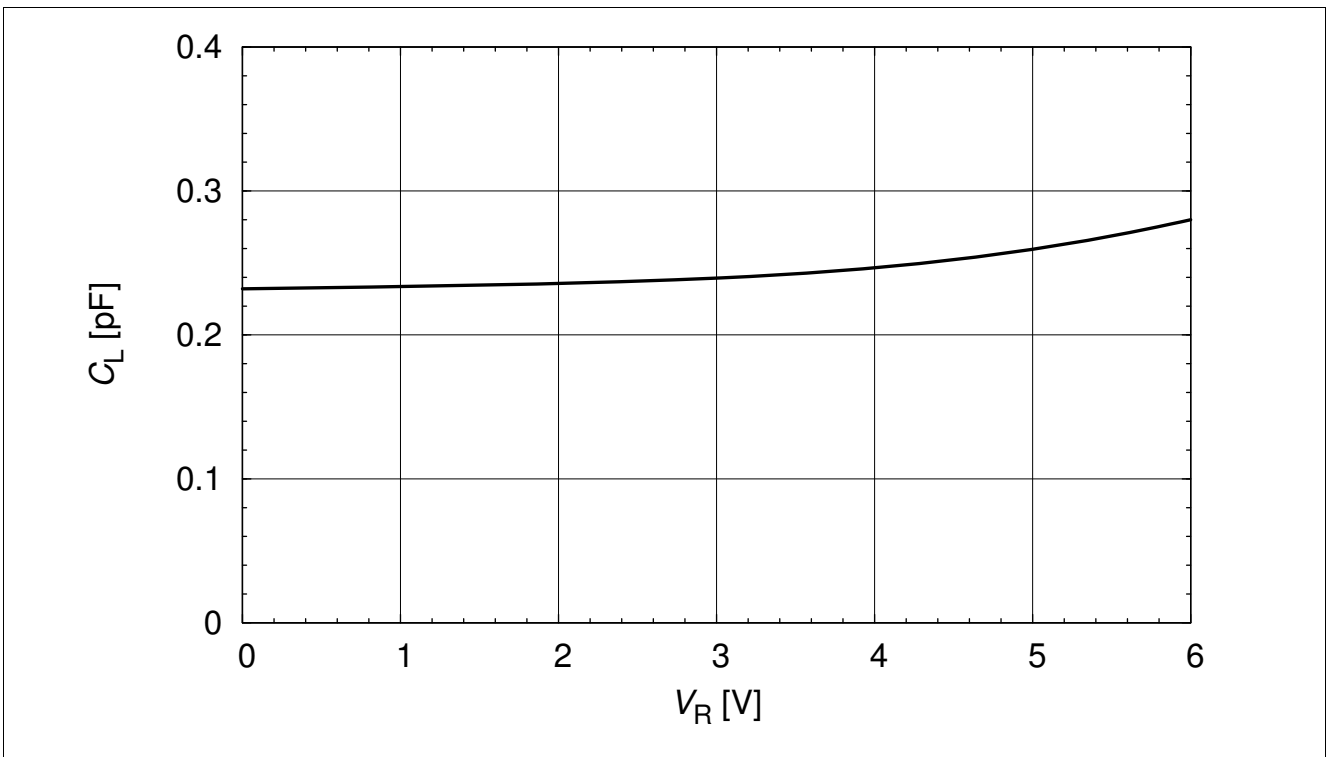

Figure 2-3 Line capacitance: $C_L = f(V_R)$, $f = 1\text{ MHz}$

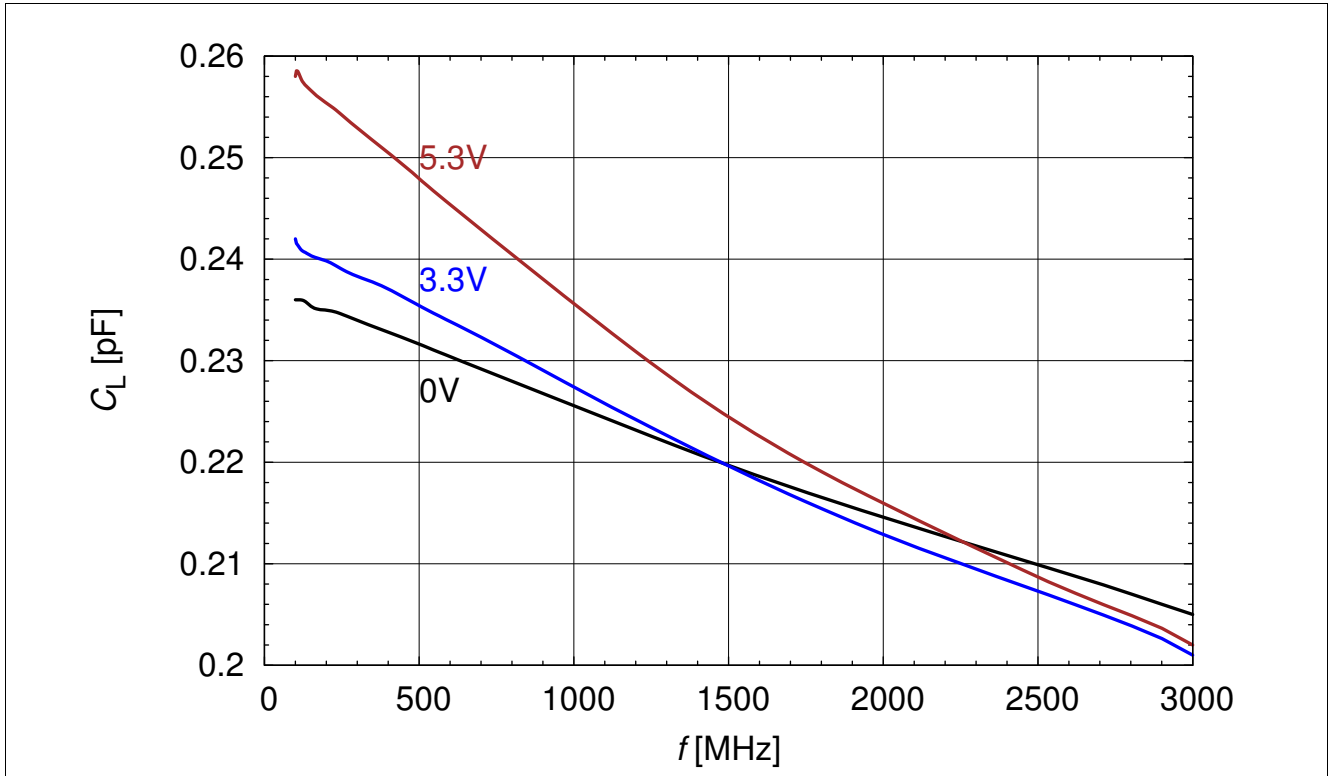

Figure 2-4 Line capacitance: $C_L = f(f)$, $V_R = \text{parameter}$

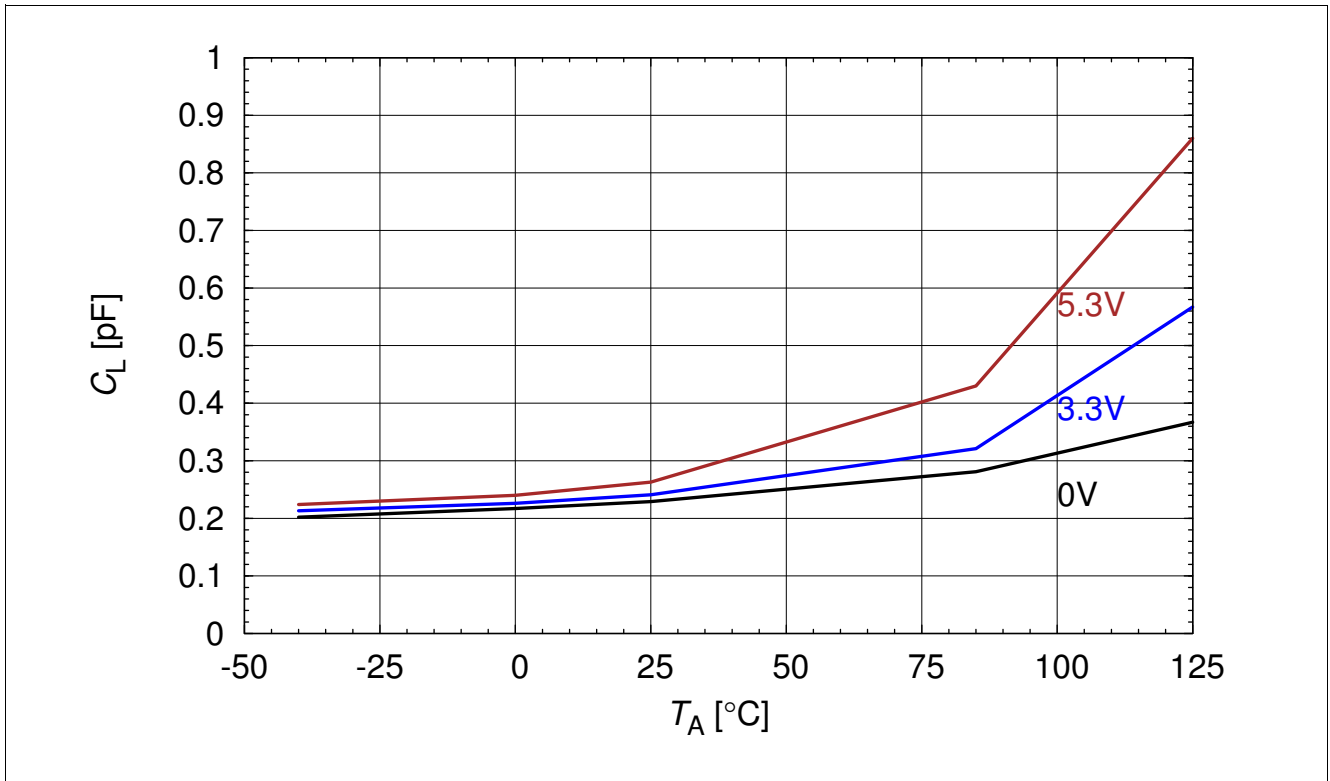

Figure 2-5 Line capacitance: $C_L = f(T_A)$, $V_R = \text{parameter}$

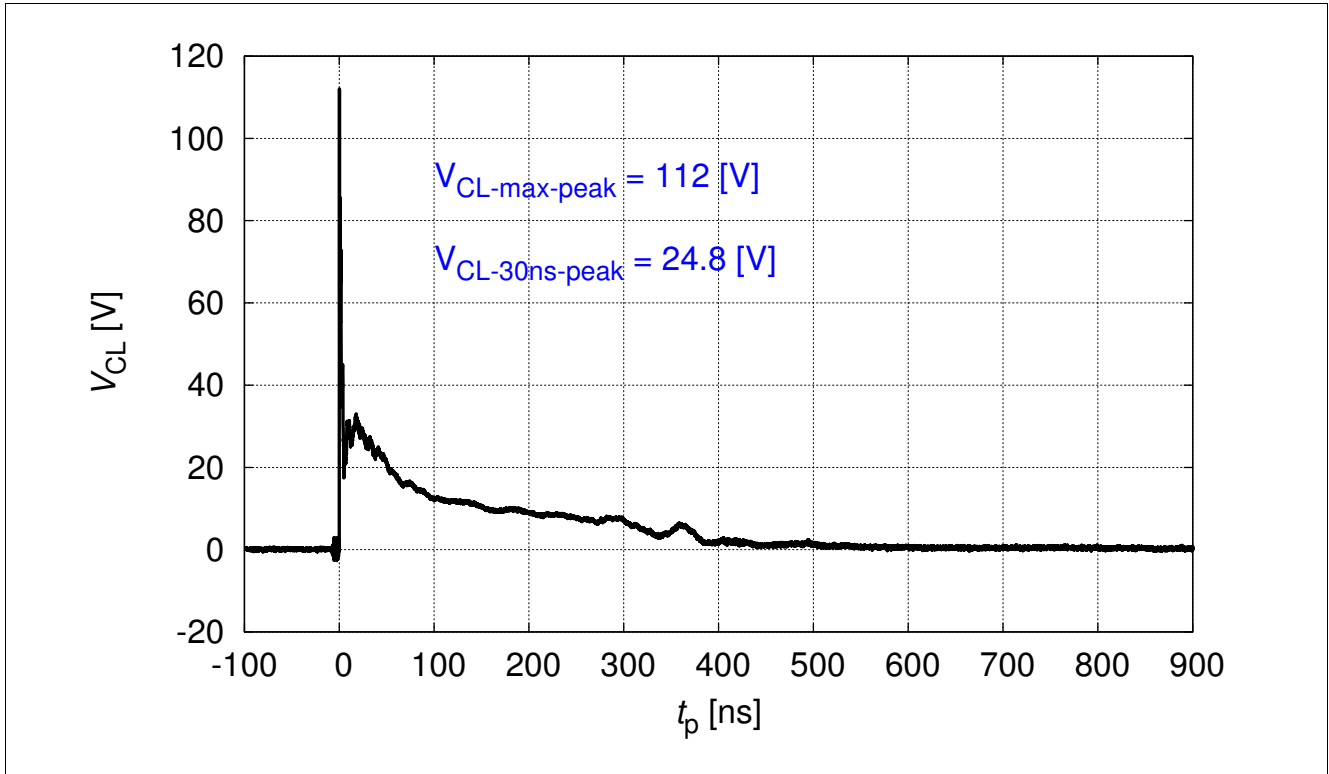

Figure 2-6 IEC61000-4-2 $V_{CL} = f(t)$, 8 kV positiv pulse from pin 1 to pin 2

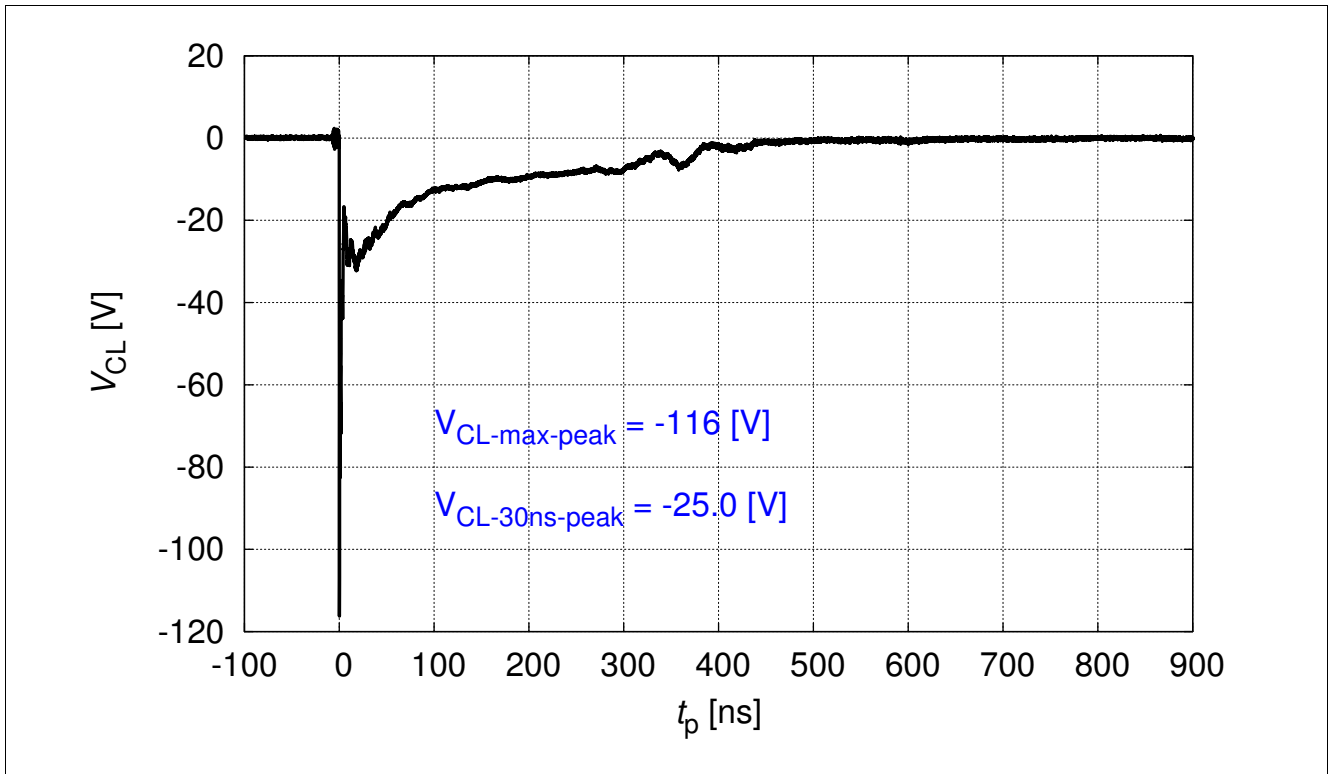

Figure 2-7 IEC61000-4-2 $V_{CL} = f(t)$, 8 kV negativ pulse from pin 1 to pin 2

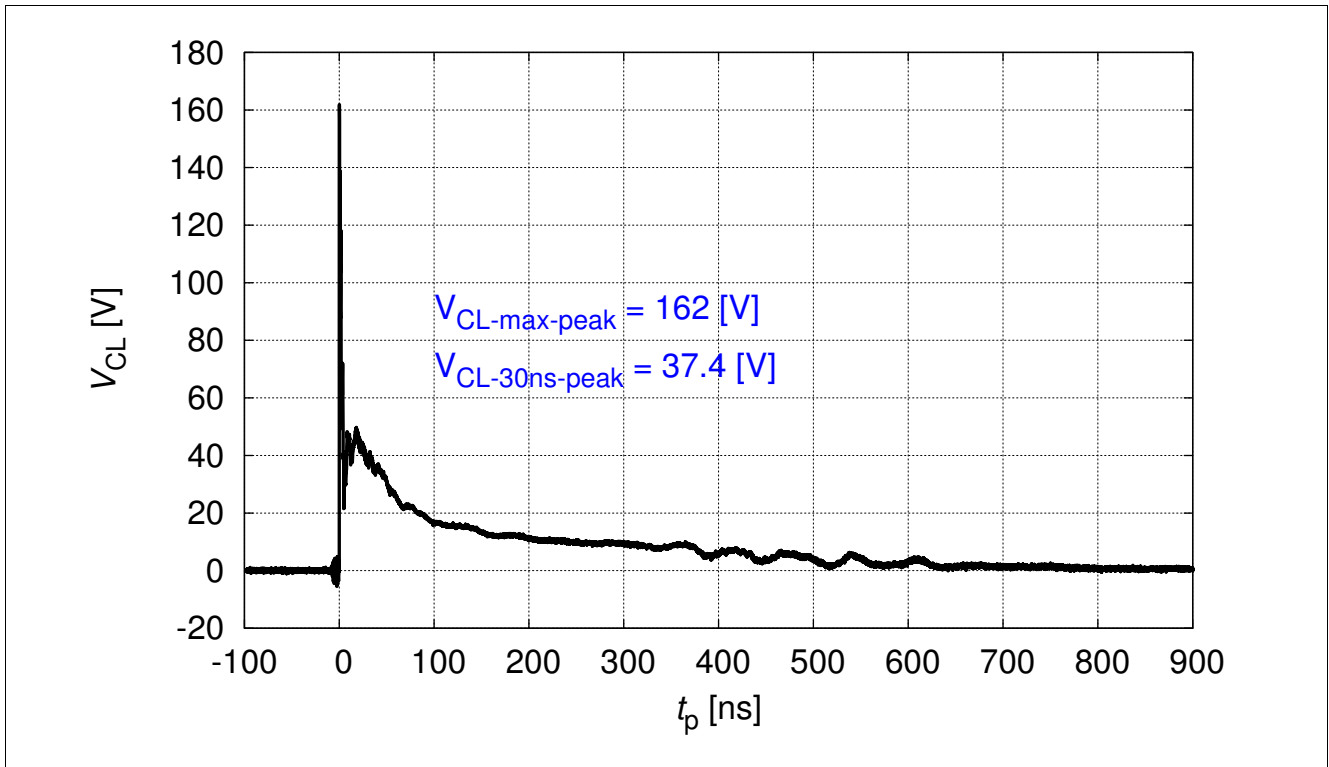

Figure 2-8 IEC61000-4-2 $V_{CL} = f(t)$, 15 kV positiv pulse from pin 1 to pin 2

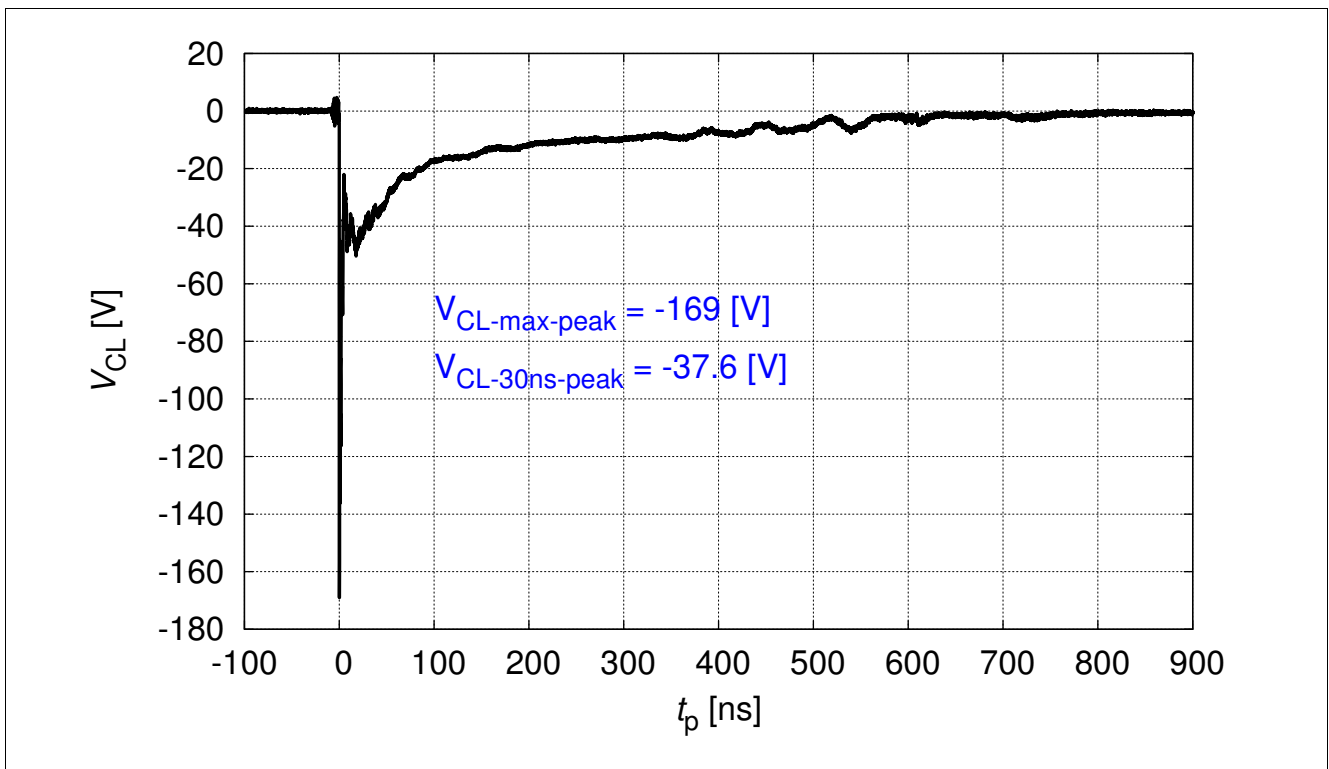

Figure 2-9 IEC61000-4-2 $V_{CL} = f(t)$, 15 kV negativ pulse from pin 1 to pin 2

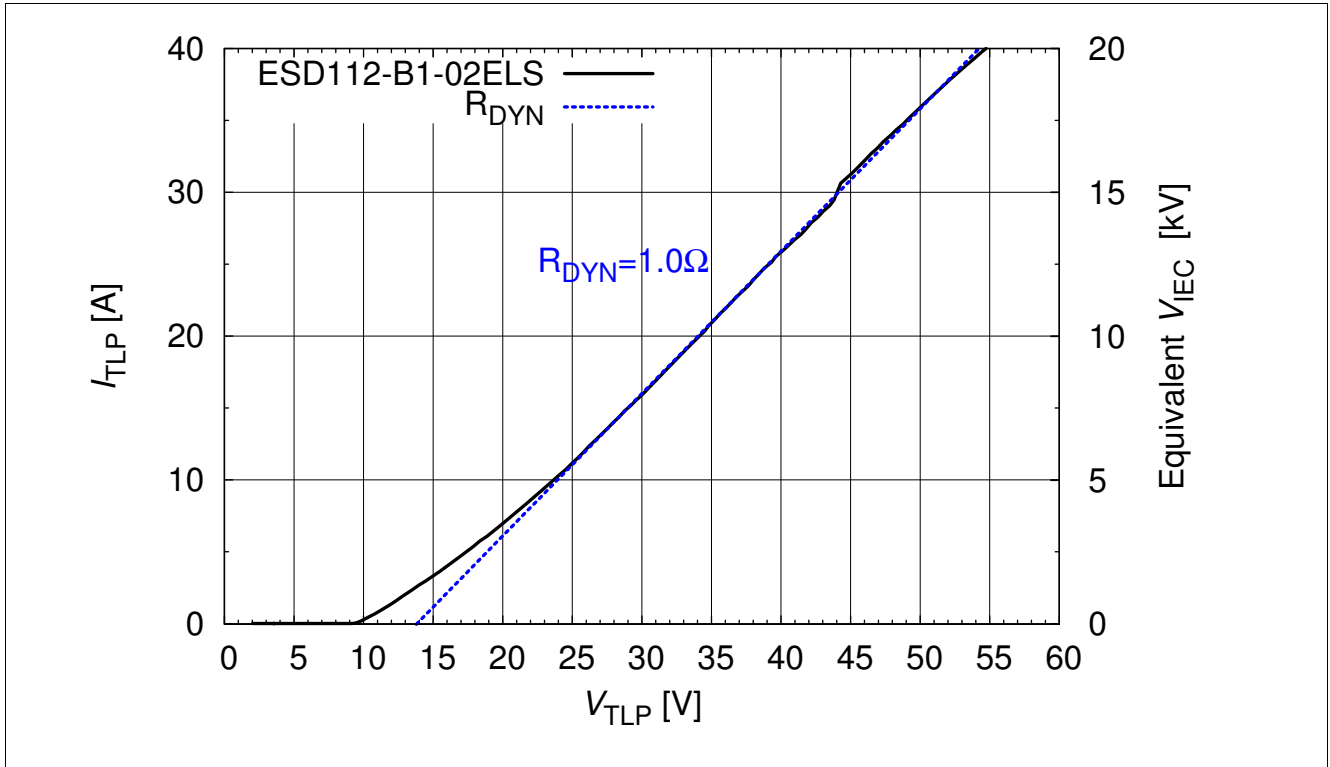

Figure 2-10 Clamping voltage : $I_{TLP} = f(V_{TLP})$ [4]

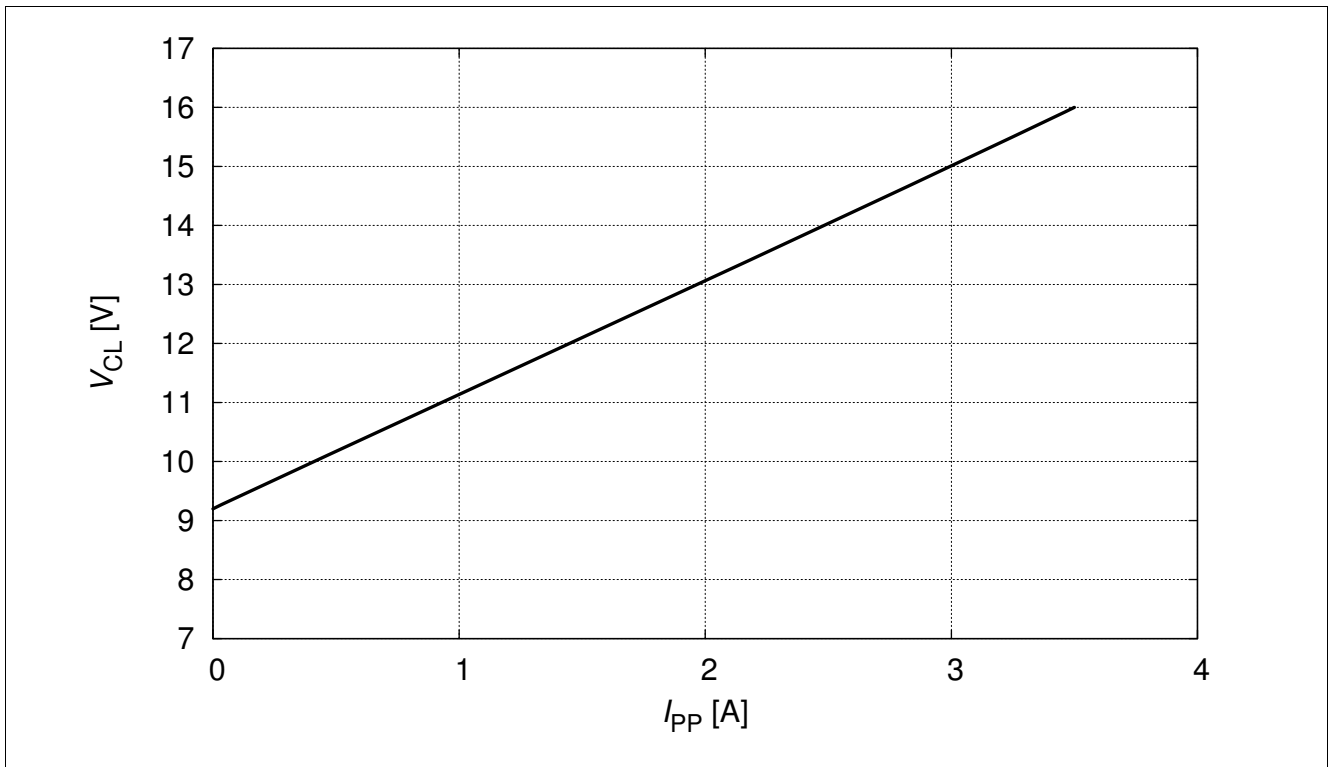

Figure 2-11 Clamp voltage: $V_{CL} = f(I_{PP})$, $t_p = 8/20 \mu s$

3 Application Information

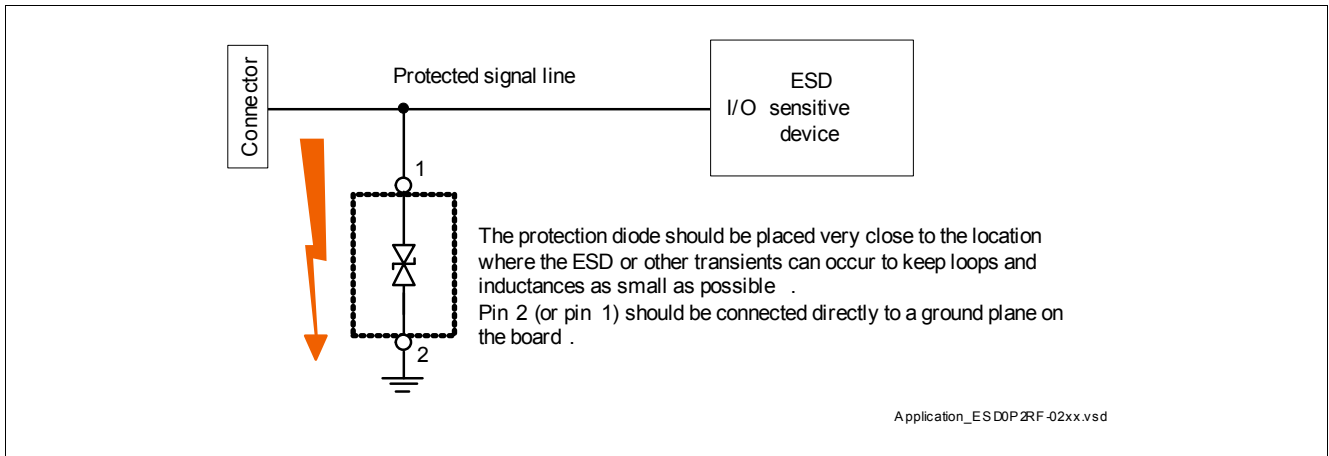

Figure 3-1 Single line, bi-directional ESD / Transient protection [1], [2]

4 Package Information

4.1 TSSLP-2-4 (mm) [5]

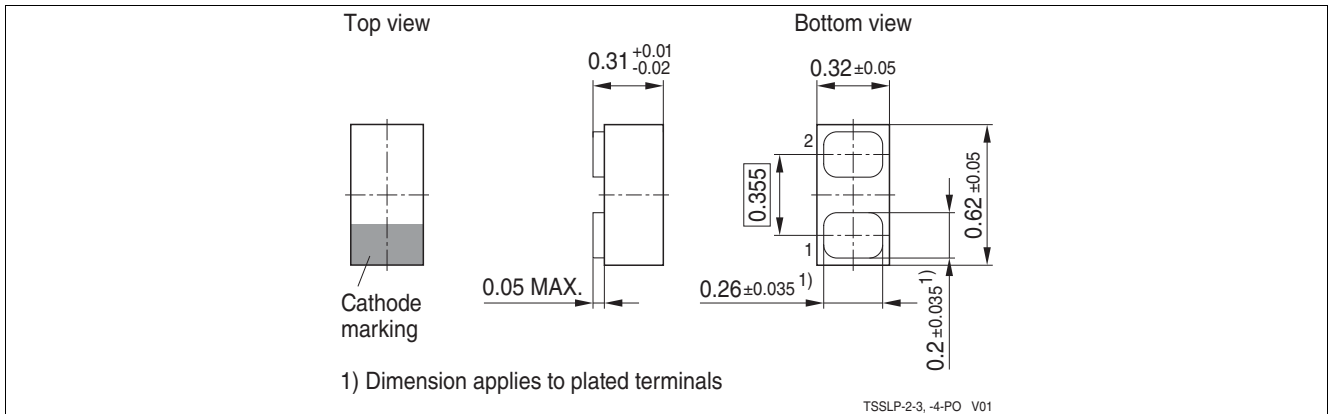

Figure 4-1 TSSLP-2-4 Package overview

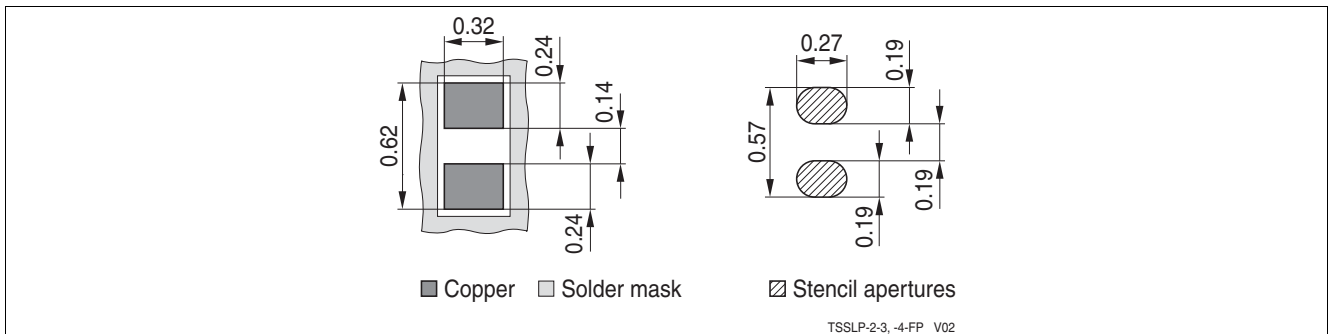

Figure 4-2 TSSLP-2-4: Footprint

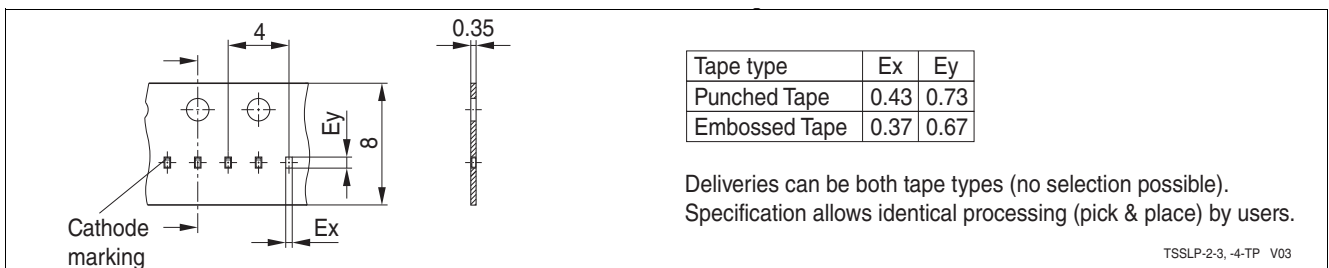

Figure 4-3 TSSLP-2-4: Packing

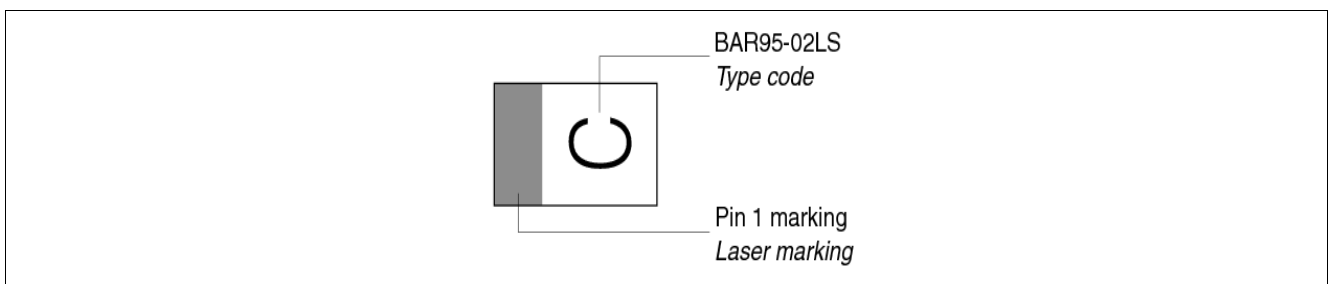

Figure 4-4 TSSLP-2-4: Marking (example)

4.2 TSLP-2-20 (mm) [5]

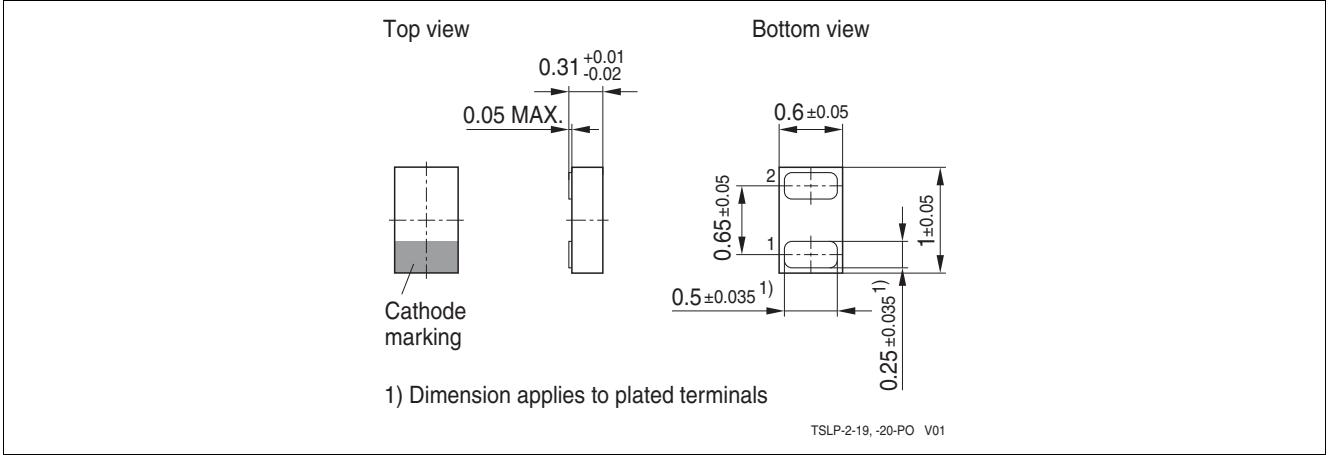

Figure 4-5 TSLP-2-20: Package overview

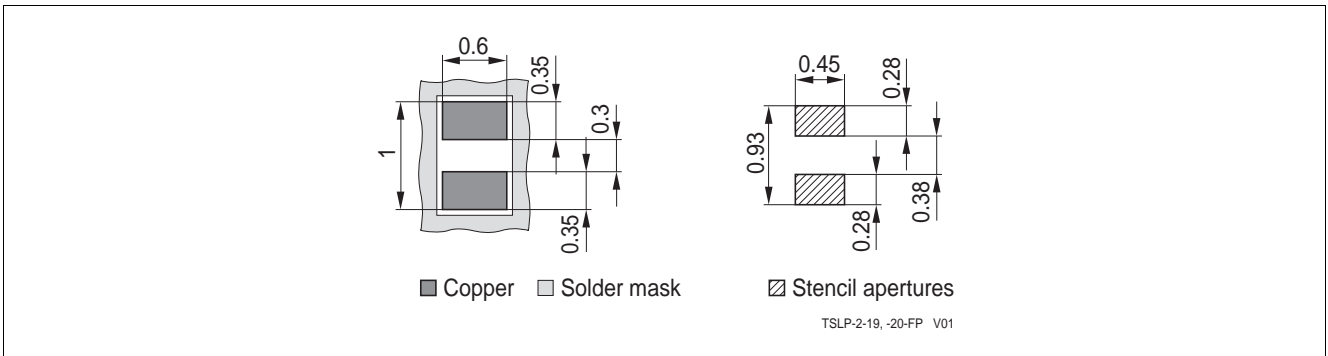

Figure 4-6 TSLP-2-20: Footprint

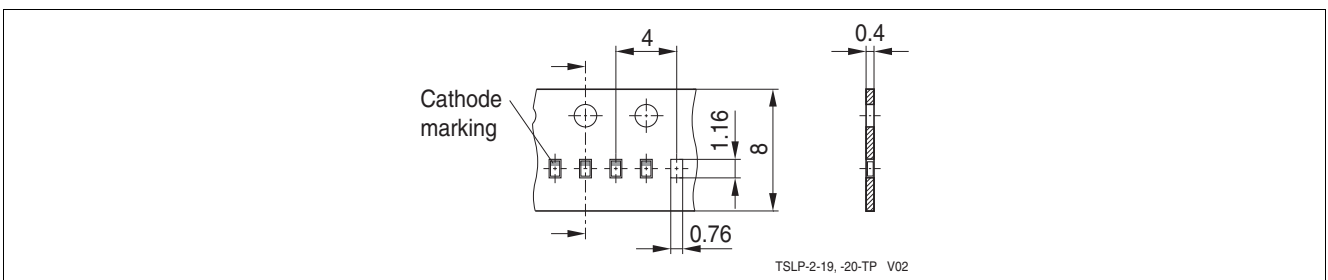

Figure 4-7 TSLP-2-20: Packing

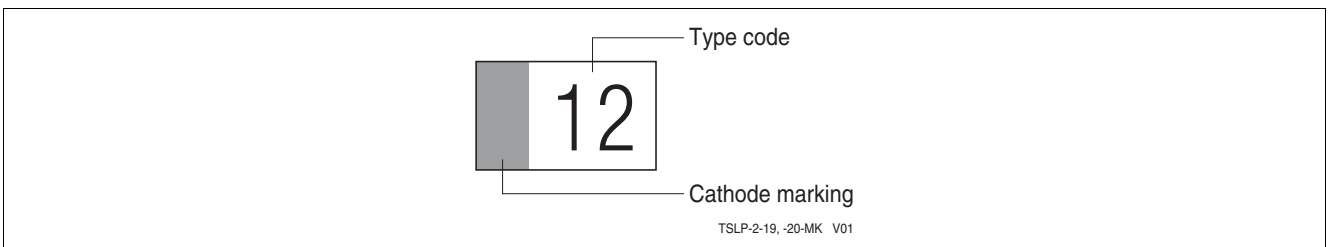

Figure 4-8 TSLP-2-20: Marking (example)

References

- [1] Infineon AG - **Application Note AN167**: ESD Protection for Broadband LNA BGA728L7 for Portable and Mobile TV Applications
- [2] Infineon AG - **Application Note AN178**: ESD Protection for RF Antennas using Infineon ESD0P4RFL and ESD0P2RF-xx
- [3] Infineon AG - **Application Note AN200**: Low Cost FM Radio LNA using BFR340F for Mobile Phone Applications
- [4] Infineon AG - **Application Note AN210**: Effective ESD Protection Design at System Level using VF-TLP Characterization Methodology
- [5] Infineon AG - Recommendations for PCB Assembly of Infineon TSLP and TSSLP Packages

www.infineon.com

Published by Infineon Technologies AG

Данный компонент на территории Российской Федерации

Вы можете приобрести в компании MosChip.

Для оперативного оформления запроса Вам необходимо перейти по данной ссылке:

<http://moschip.ru/get-element>

Вы можете разместить у нас заказ для любого Вашего проекта, будь то серийное производство или разработка единичного прибора.

В нашем ассортименте представлены ведущие мировые производители активных и пассивных электронных компонентов.

Нашей специализацией является поставка электронной компонентной базы двойного назначения, продукции таких производителей как XILINX, Intel (ex.ALTERA), Vicor, Microchip, Texas Instruments, Analog Devices, Mini-Circuits, Amphenol, Glenair.

Сотрудничество с глобальными дистрибьюторами электронных компонентов, предоставляет возможность заказывать и получать с международных складов практически любой перечень компонентов в оптимальные для Вас сроки.

На всех этапах разработки и производства наши партнеры могут получить квалифицированную поддержку опытных инженеров.

Система менеджмента качества компании отвечает требованиям в соответствии с ГОСТ Р ИСО 9001, ГОСТ РВ 0015-002 и ЭС РД 009

Офис по работе с юридическими лицами:

105318, г.Москва, ул.Щербаковская д.3, офис 1107, 1118, ДЦ «Щербаковский»

Телефон: +7 495 668-12-70 (многоканальный)

Факс: +7 495 668-12-70 (доб.304)

E-mail: info@moschip.ru

Skype отдела продаж:

moschip.ru

moschip.ru_4

moschip.ru_6

moschip.ru_9