

Installation Instructions for the SS500 Series Temperature Compensated Hall Effect Sensors

ISSUE 1
50035318

GENERAL INFORMATION

CAUTION

ELECTROSTATIC DISCHARGE DAMAGE

This component is sensitive to electrostatic discharge (ESD). Take normal ESD precautions in handling this product to prevent ESD-induced damage and/or degradation.

Failure to comply with these instructions will result in product damage.

CAUTION

WAVE SOLDER DAMAGE

DO NOT wave solder this product. Wave soldering may negatively affect the sensor performance and reliability. Subjecting the sensor to wave soldering will void Honeywell's warranty.

Failure to comply with these instructions will result in product damage.

Figure 1. Block Diagram

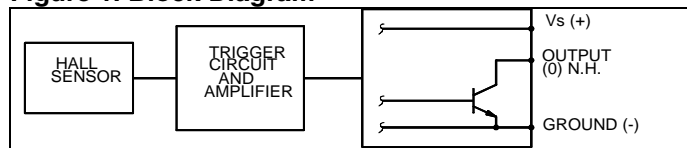

Table 2. Operating Characteristics (over operating voltage and temperature, unless otherwise noted)

Characteristic	Min.	Typ.	Max.	Note
Supply voltage	3.8	—	30	Vdc
Current consumption	—	—	10	mA
Output voltage (operated)	—	0.15	0.40	sinking 20 mA max.
Output current (operated)	—	—	20 mA	—
Output leakage current (released)	—	—	10 μ A	—
Output switching time	—	—	—	$V_{cc} = 12 V$,
rise, 10% to 90%	—	0.05 μ s	1.5 μ s	$R_L = 1.6 k\Omega$,
fall, 90% to 10%	—	0.15 μ s	1.5 μ s	$C_L = 20 pF$
Operating temperature range	-40 °C to 125 °C [-40 °F to 302 °F]			

Note: To prevent damage to the leads, SS500 Series is supplied **only** on tape and reel.

Table 1. Absolute Maximum Ratings*

Supply voltage	-1 Vdc to +30 Vdc
Voltage externally applied to output	+30 Vdc max. (OFF only) -0.5 Vdc min. (OFF or ON)
Output ON current	see Table 3
Operating temperature	-50 °C to 160 °C [-67 °F to 320 °F]
Storage temperature	-65 °C to 160 °C [-85 °F to 320 °F]
Magnetic flux	no limit - circuit cannot be damaged by magnetic overdrive

*Absolute maximum ratings are the extreme limits that the device will withstand without damage to the device. However, the electrical and mechanical characteristics are not guaranteed as the maximum limits (above recommended operating conditions) are approached, nor will the device necessarily operate at absolute maximum ratings.

SOLDERING INSTRUCTIONS

Honeywell recommends an infrared reflow process with peak temperatures not to exceed 245 °C [473 °F] for 10 seconds maximum.

Table 3. Output Current Absolute Limits

Supply Voltage	Output Current
-1 Vdc to 24 Vdc	50 mA max.
24 Vdc to 25 Vdc	37 mA max.
25 Vdc to 26 Vdc	33 mA max.
26 Vdc to 27 Vdc	28 mA max.
28 Vdc to 29 Vdc	19 mA max.
29 Vdc to 30 Vdc	15 mA max.

Table 4. Magnetic Characteristics

Magnetic Type		SS511GT	SS513GT	SS541GT	SS543GT	SS549GT	SS561GT	SS566GT
		Bipolar	Bipolar	Unipolar	Unipolar	Unipolar	Latching	Latching
-40 °C	max. op.	70 G	140 G	135 G	215 G	435 G	110 G	200 G
	min. rel.	-70 G	-140 G	20 G	80 G	210 G	-110 G	-200 G
	min. dif.	15 G	20 G	15 G	25 G	30 G	50 G	200 G
0 °C	max. op.	65 G	140 G	117 G	190 G	400 G	90 G	185 G
	min. rel.	-65 G	-140 G	20 G	80 G	230 G	-90 G	-185 G
	min. dif.	15 G	20 G	15 G	25 G	30 G	50 G	200 G
25 °C	max. op.	60 G	140 G	115 G	180 G	390 G	85 G	180 G
	min. rel.	-60 G	-140 G	20 G	75 G	235 G	-85 G	-180 G
	min. dif.	15 G	20 G	20 G	25 G	30 G	50 G	200 G
85 °C	max. op.	60 G	140 G	120 G	180 G	400 G	85 G	180 G
	min. rel.	-60 G	-140 G	15 G	70 G	215 G	-85 G	-180 G
	min. dif.	12 G	20 G	15 G	15 G	30 G	50 G	190 G
125 °C	max. op.	65 G	140 G	123 G	190 G	410 G	100 G	180 G
	min. rel.	-65 G	-140 G	15 G	60 G	200 G	-100 G	-180 G
	min. dif.	12 G	20 G	8 G	10 G	30 G	50 G	160 G
150 °C	max. op.	70 G	140 G	125 G	200 G	420 G	110 G	185 G
	min. rel.	-70 G	-140 G	10 G	55 G	185 G	-110 G	-185 G
	min. dif.	10 G	20 G	5 G	5 G	30 G	50 G	140 G

NOTICE

Bipolar Hall effect sensors may have an initial output in either the ON or OFF state if powered up with an applied magnetic field in the differential zone (applied magnetic field >Brp and <Bop). Honeywell recommends allowing 10 μs for output voltage to stabilize after supply voltage has reached 5 V.

Figure 2. Interface Diagrams

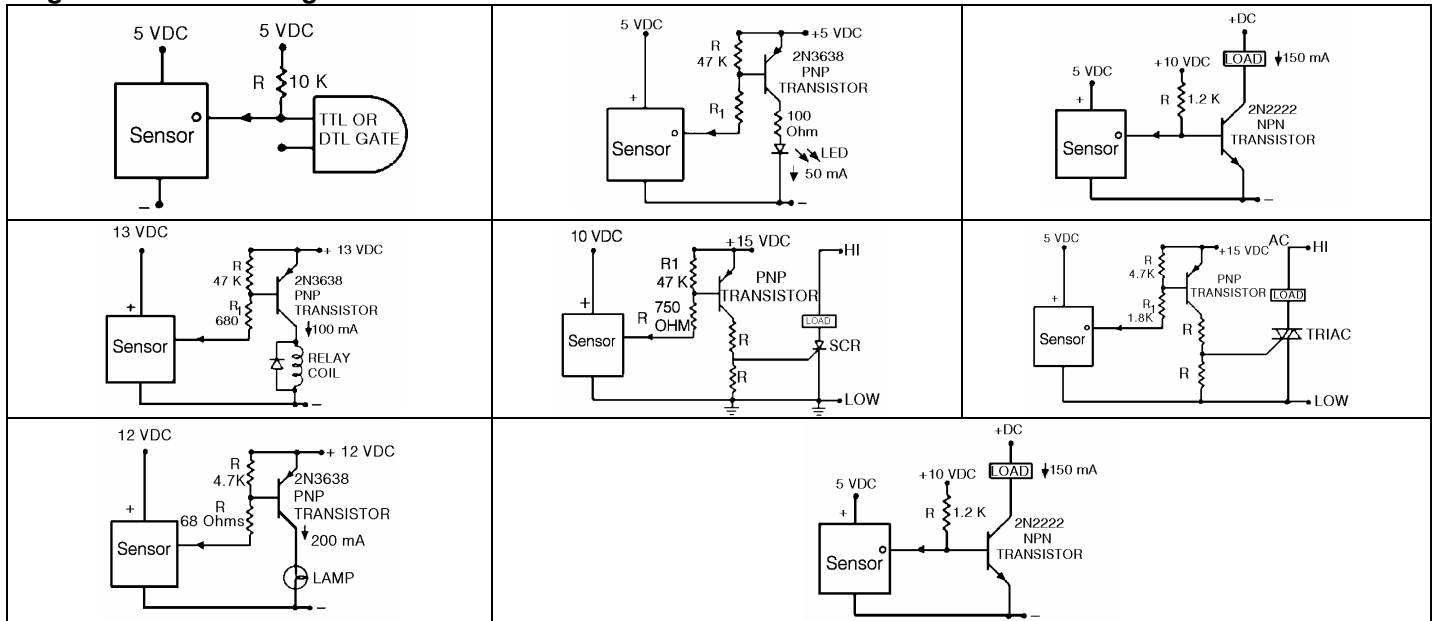

Figure 3. Mounting Dimensions (For reference only: mm/in)

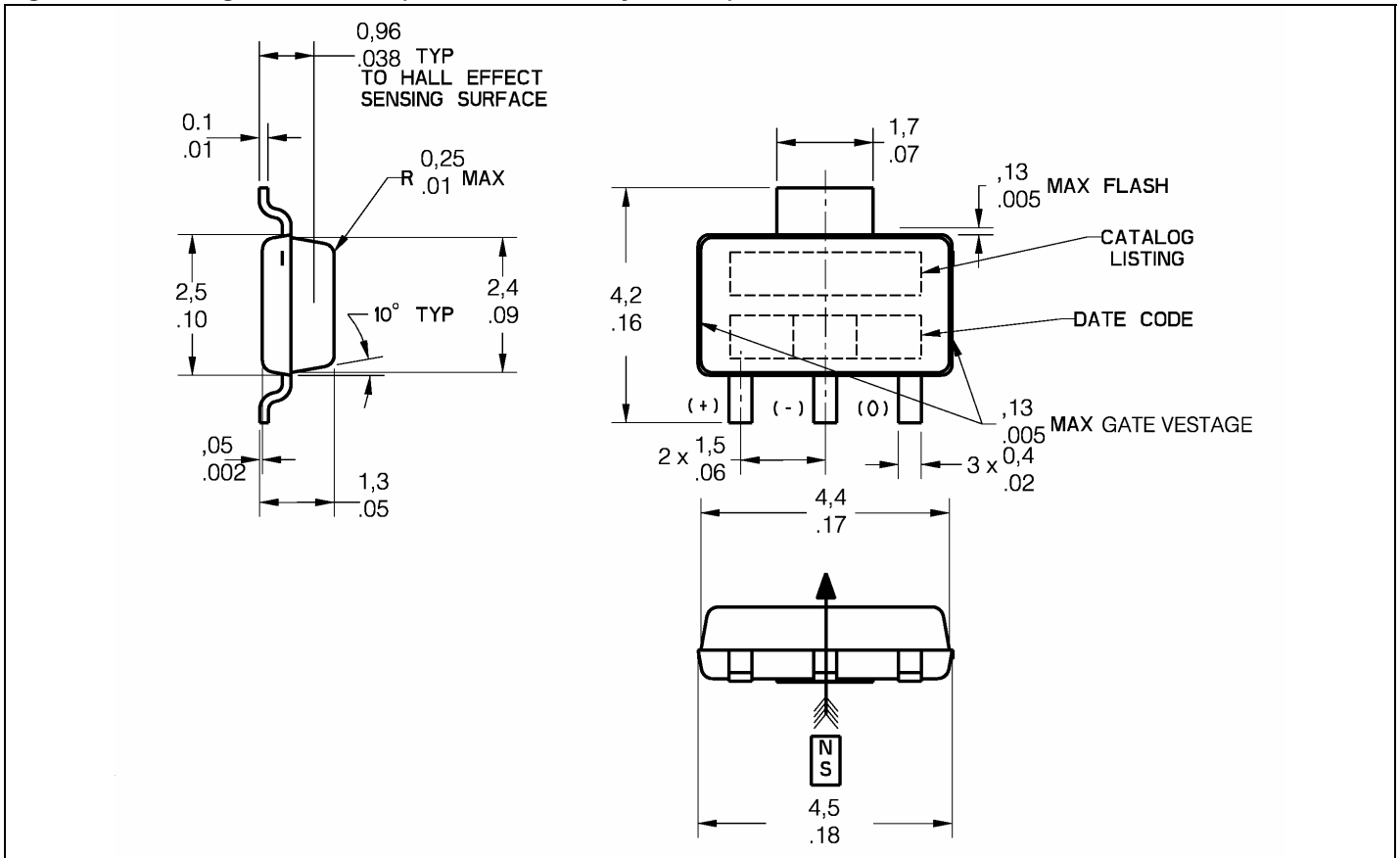
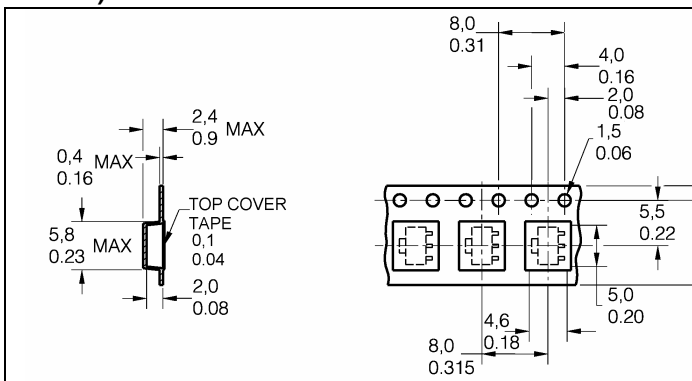
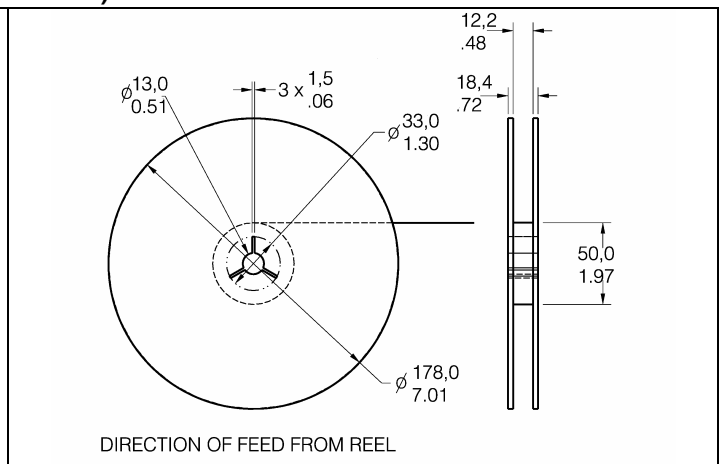

Figure 4. Tape Dimensions (For reference only: mm/in)*



*This product is sold in tape and reel form only, per EIA STD 481. There are 1,000 units per reel.

Figure 5. Reel Dimensions (For reference only: mm/in)



WARNING

PERSONAL INJURY

DO NOT USE these products as safety or emergency stop devices or in any other application where failure of the product could result in personal injury.

Failure to comply with these instructions could result in death or serious injury.

WARRANTY/REMEDY

Honeywell warrants goods of its manufacture as being free of defective materials and faulty workmanship. Honeywell's standard product warranty applies unless agreed to otherwise by Honeywell in writing; please refer to your order acknowledgement or consult your local sales office for specific warranty details. If warranted goods are returned to Honeywell during the period of coverage, Honeywell will repair or replace, at its option, without charge those items it finds defective. **The foregoing is buyer's sole remedy and is in lieu of all other warranties, expressed or implied, including those of merchantability and fitness for a particular purpose. In no event shall Honeywell be liable for consequential, special, or indirect damages.**

While we provide application assistance personally, through our literature and the Honeywell web site, it is up to the customer to determine the suitability of the product in the application.

Specifications may change without notice. The information we supply is believed to be accurate and reliable as of this printing. However, we assume no responsibility for its use.

SALES AND SERVICE

Honeywell serves its customers through a worldwide network of sales offices, representatives and distributors. For application assistance, current specifications, pricing or name of the nearest Authorized Distributor, contact your local sales office or:

E-mail: info.sc@honeywell.com

Internet: www.honeywell.com/sensing

Phone and Fax:

Asia Pacific	+65 6355-2828
	+65 6445-3033 Fax
Europe	+44 (0) 1698 481481
	+44 (0) 1698 481676 Fax
Latin America	+1-305-805-8188
	+1-305-883-8257 Fax
USA/Canada	+1-800-537-6945
	+1-815-235-6847
	+1-815-235-6545 Fax

Данный компонент на территории Российской Федерации

Вы можете приобрести в компании MosChip.

Для оперативного оформления запроса Вам необходимо перейти по данной ссылке:

<http://moschip.ru/get-element>

Вы можете разместить у нас заказ для любого Вашего проекта, будь то серийное производство или разработка единичного прибора.

В нашем ассортименте представлены ведущие мировые производители активных и пассивных электронных компонентов.

Нашей специализацией является поставка электронной компонентной базы двойного назначения, продукции таких производителей как XILINX, Intel (ex.ALTERA), Vicor, Microchip, Texas Instruments, Analog Devices, Mini-Circuits, Amphenol, Glenair.

Сотрудничество с глобальными дистрибьюторами электронных компонентов, предоставляет возможность заказывать и получать с международных складов практически любой перечень компонентов в оптимальные для Вас сроки.

На всех этапах разработки и производства наши партнеры могут получить квалифицированную поддержку опытных инженеров.

Система менеджмента качества компании отвечает требованиям в соответствии с ГОСТ Р ИСО 9001, ГОСТ РВ 0015-002 и ЭС РД 009

Офис по работе с юридическими лицами:

105318, г.Москва, ул.Щербаковская д.3, офис 1107, 1118, ДЦ «Щербаковский»

Телефон: +7 495 668-12-70 (многоканальный)

Факс: +7 495 668-12-70 (доб.304)

E-mail: info@moschip.ru

Skype отдела продаж:

moschip.ru

moschip.ru_4

moschip.ru_6

moschip.ru_9